



US00D705128S

(12) **United States Design Patent**
Patterson et al.

(10) **Patent No.:** **US D705,128 S**

(45) **Date of Patent:** **** May 20, 2014**

(54) **GO-KART**

D453,710 S * 2/2002 Hettich et al. D12/86
D453,711 S * 2/2002 Hettich et al. D12/86
8,042,811 B1 * 10/2011 Markowitz et al. 273/148 B

(75) Inventors: **Wayne Patterson**, Oakland, OR (US);
Johnny Liao, Irvine, CA (US)

FOREIGN PATENT DOCUMENTS

(73) Assignee: **APT IP Holdings LLC**, Kansas City,
MO (US)

JP 2003251078 A * 9/2003 A63G 25/00
WO WO 9715473 A2 * 5/1997 B60R 19/42

(**) Term: **14 Years**

OTHER PUBLICATIONS

(21) Appl. No.: **29/419,707**

American Sport Works. Black Widow. 2013-0413 [online], [retrieved on May 23, 2013]. Retrieved from the Internet <URL: <http://www.amsportworks.com/pdfs/gokarts-minibikes/black-widow-hangtag.pdf>>.*

(22) Filed: **May 1, 2012**

(51) **LOC (10) CL.** **12-08**

* cited by examiner

(52) **U.S. CL.**

USPC **D12/87**

Primary Examiner — Philip S Hyder

Assistant Examiner — Darlington Ly

(58) **Field of Classification Search**

USPC D12/1, 14, 86, 87, 88, 90, 91, 92;
D21/424, 425, 433; 180/208, 224, 291,
180/309, 311, 337, 357; 280/779, 781;
296/181.1, 181.4, 181.5

(74) *Attorney, Agent, or Firm* — Holland & Hart LLP; Bryan G. Pratt

See application file for complete search history.

(57)

CLAIM

The ornamental design for a go-kart, as shown and described.

DESCRIPTION

(56)

References Cited

U.S. PATENT DOCUMENTS

D189,746 S * 2/1961 Kurtis D12/88
D190,114 S * 4/1961 Baxter D12/88
D191,579 S * 10/1961 Thompson D12/88
D193,472 S * 8/1962 Stevens D12/88
D299,705 S * 2/1989 Carpanelli et al. D12/88
5,806,901 A * 9/1998 Tennyson et al. 293/136
5,855,386 A * 1/1999 Atkins 280/124.111
5,921,341 A * 7/1999 Atkins 180/350
6,056,080 A * 5/2000 Clavel 180/291
D452,188 S * 12/2001 Hettich et al. D12/86

FIG. 1 is a front perspective view of the go-kart;

FIG. 2 is a top plan view thereof;

FIG. 3 is a front elevation view thereof;

FIG. 4 is a bottom plan view thereof;

FIG. 5 is a left side elevation view thereof;

FIG. 6 is a rear elevation view thereof; and,

FIG. 7 is a right side elevation view thereof.

The broken lines shown in the drawings illustrate portions of the go-kart that forms no part of claimed design.

1 Claim, 7 Drawing Sheets

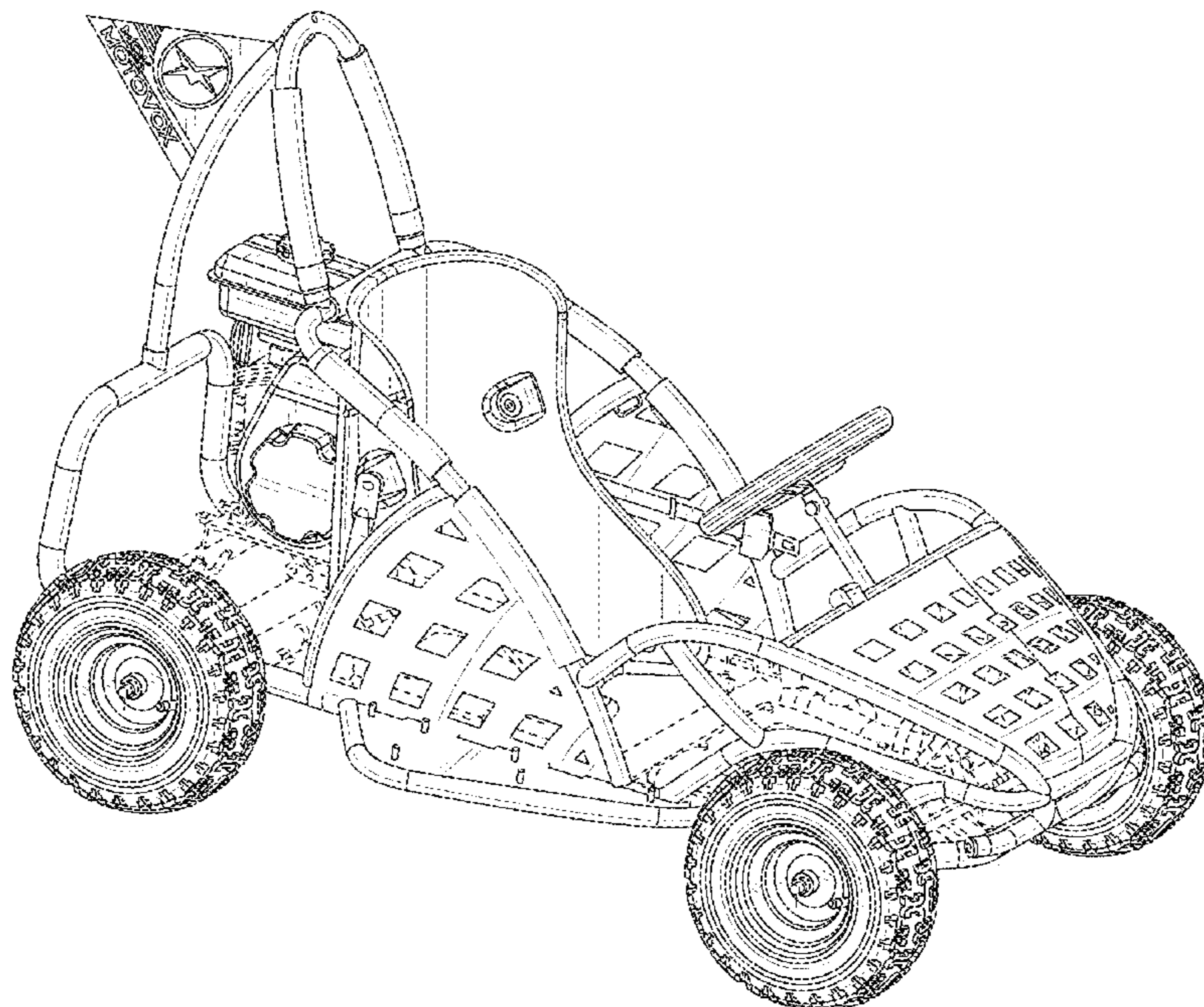

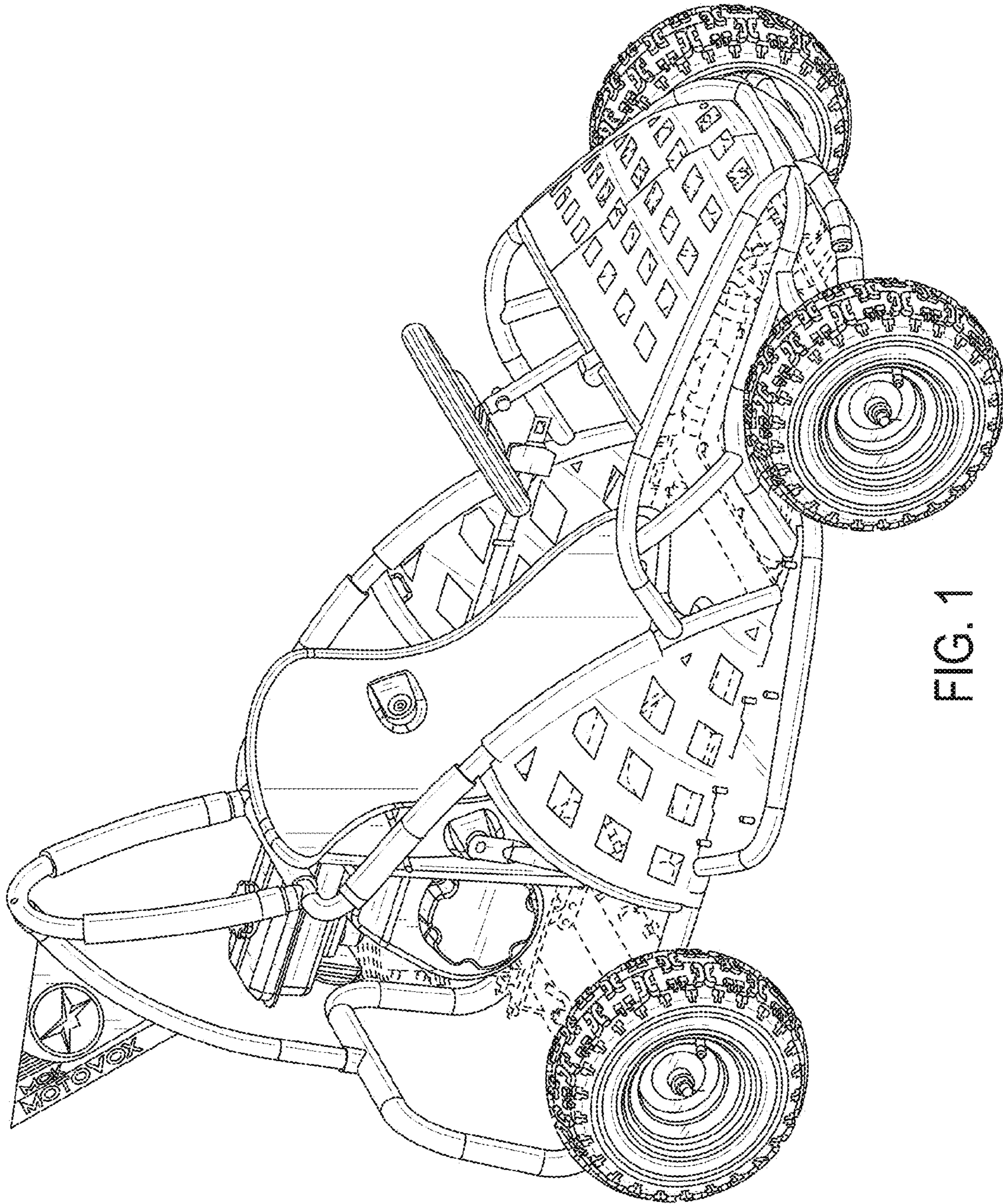

FIG. 1

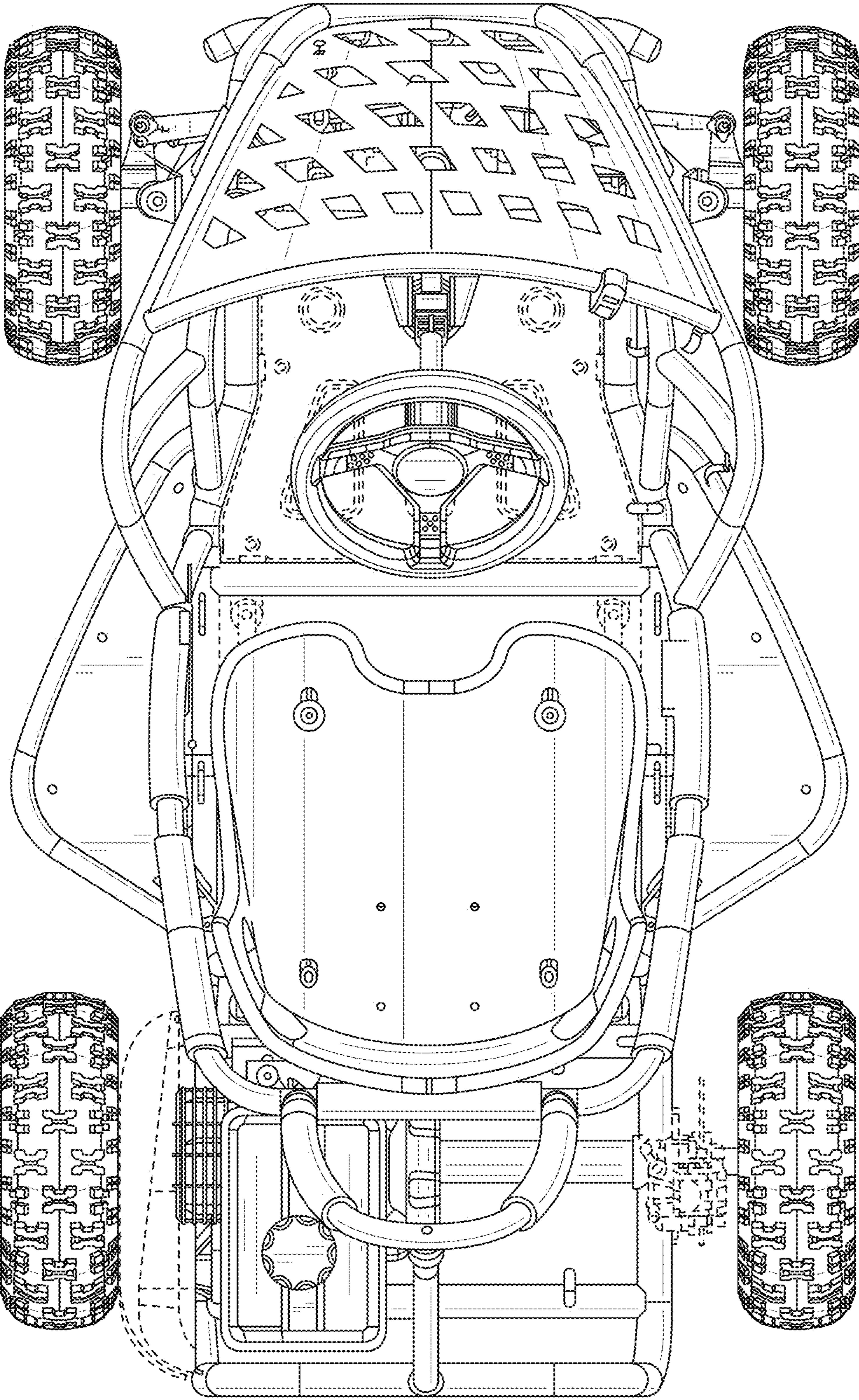

FIG. 2

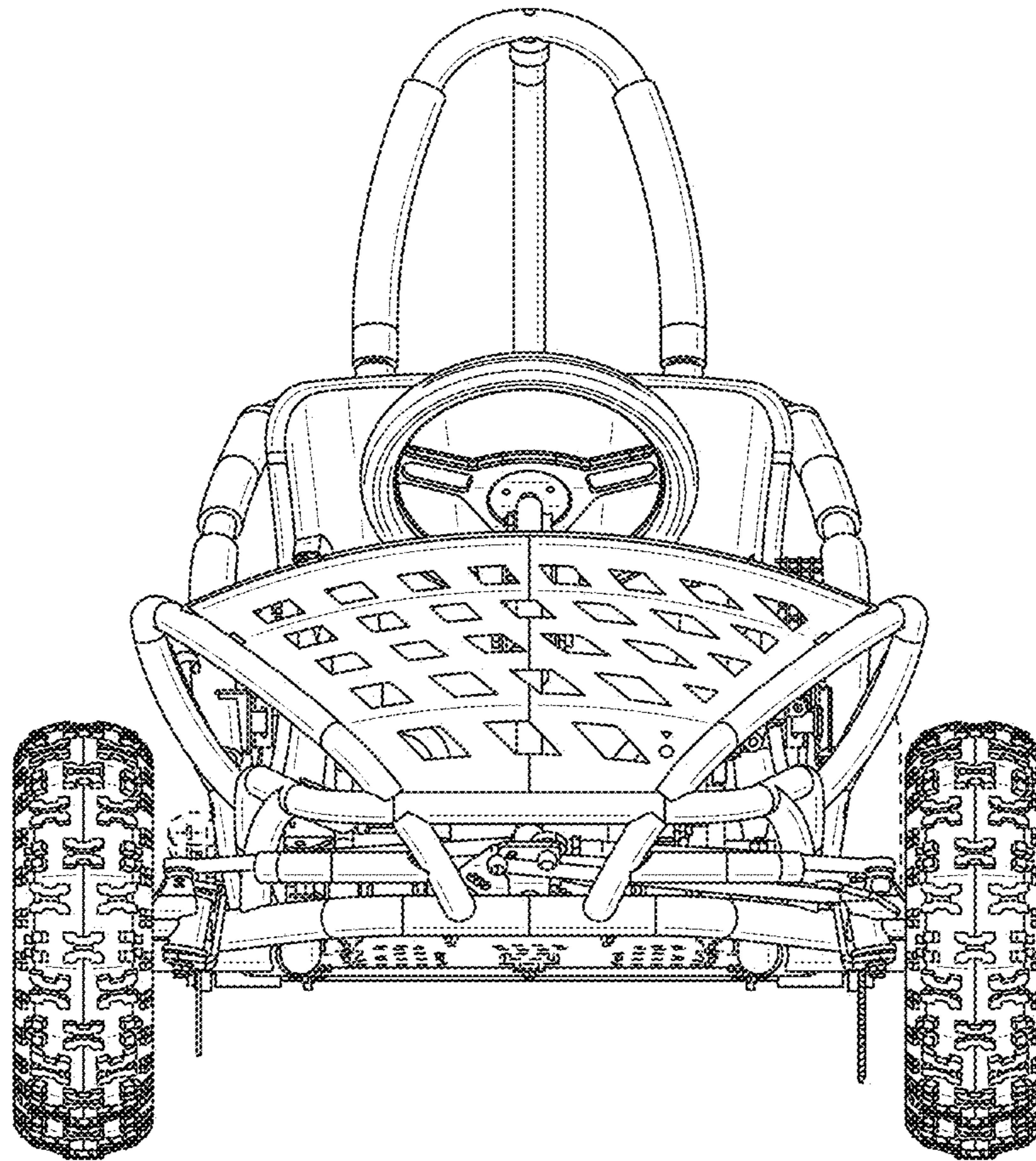

FIG. 3

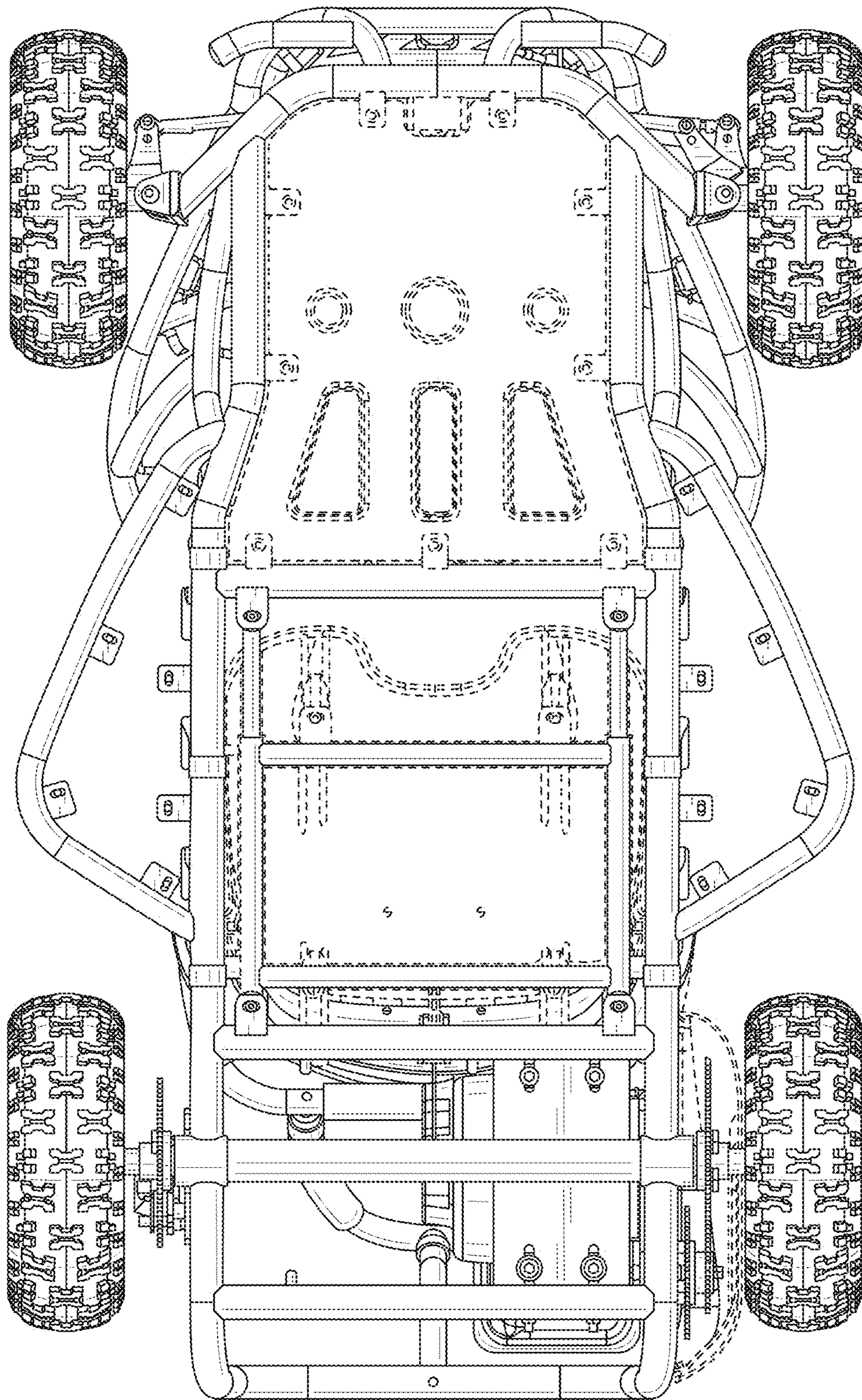

FIG. 4

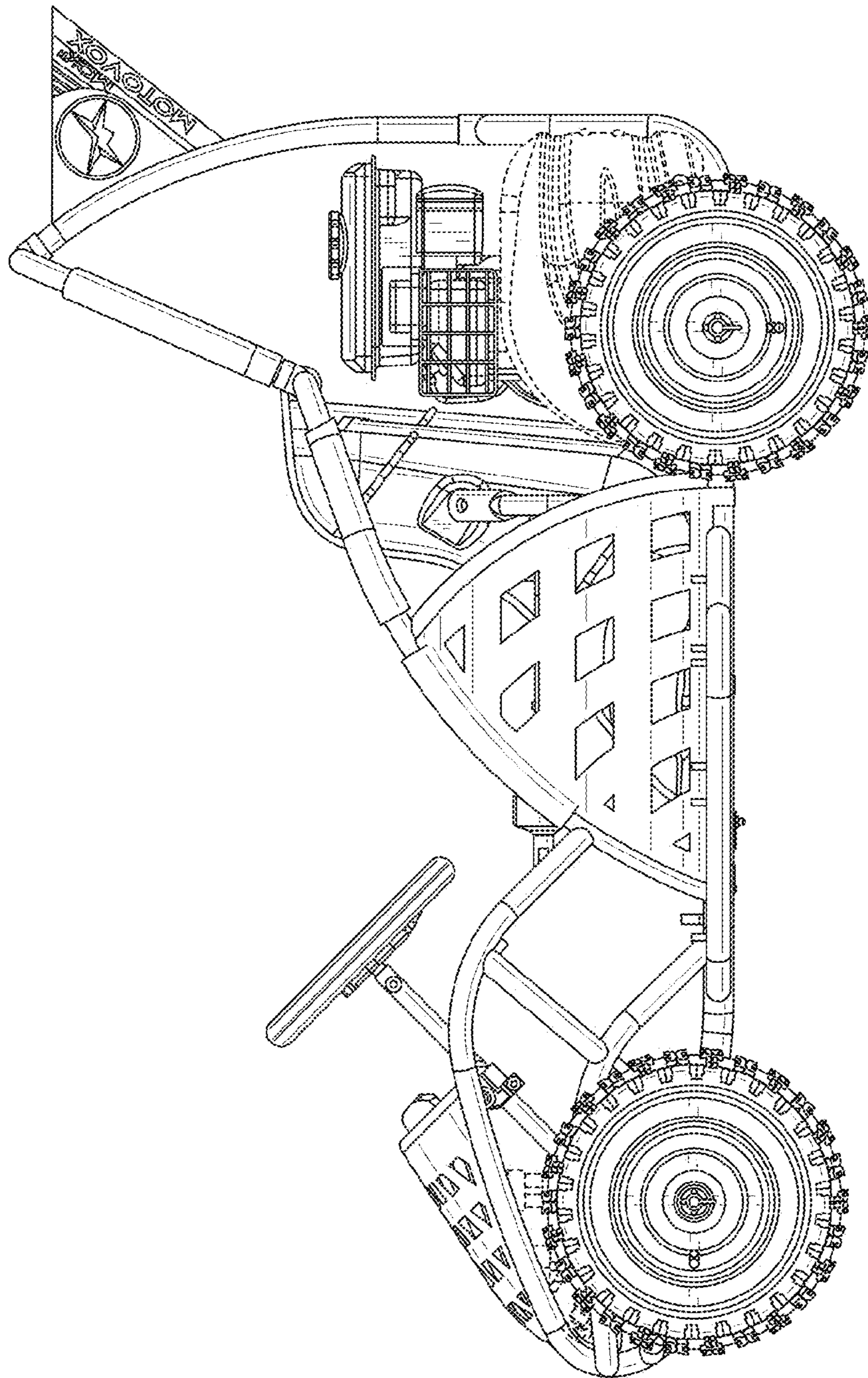

FIG. 5

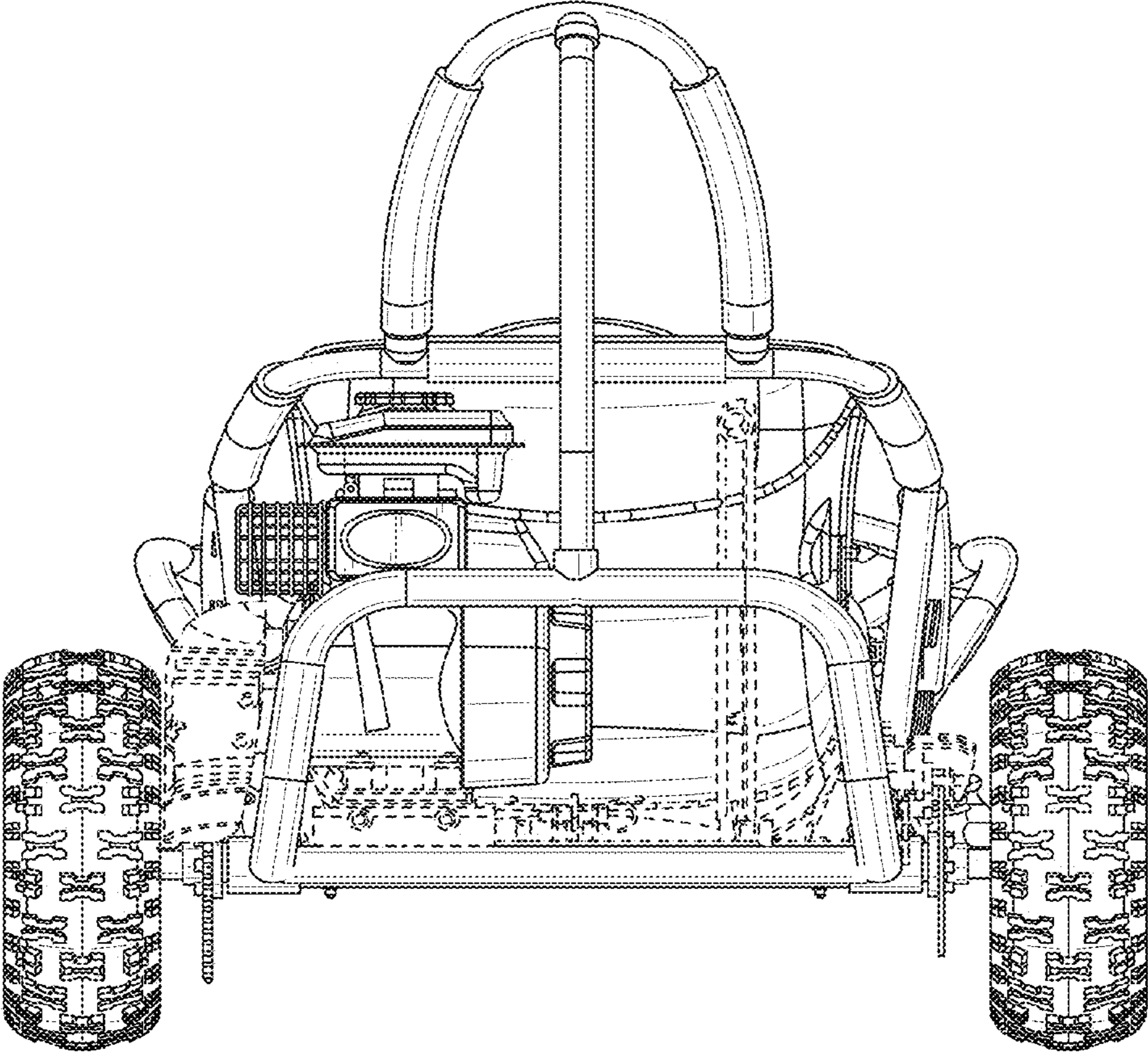

FIG. 6

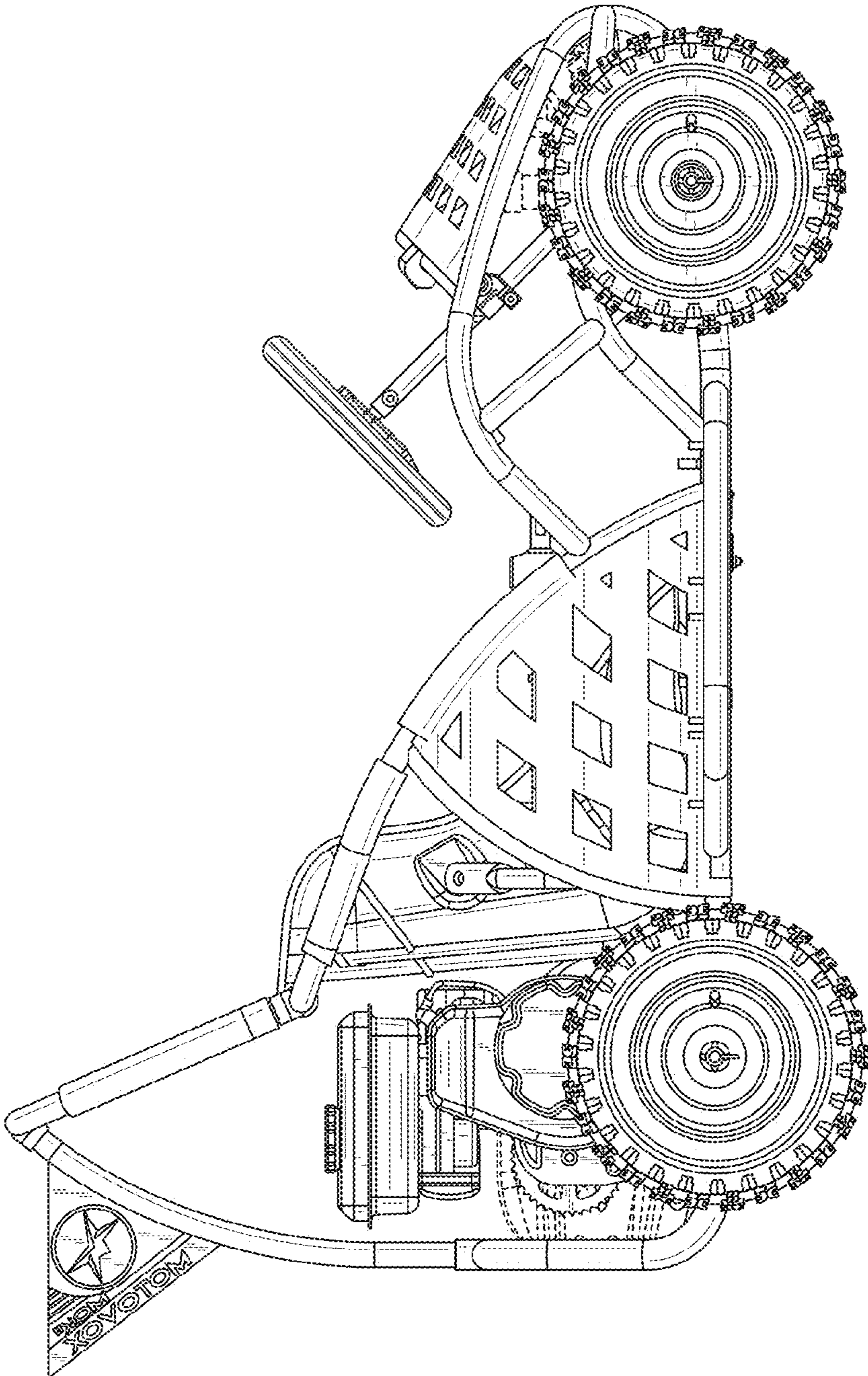

FIG. 7