



US00D705097S

(12) **United States Design Patent**
Matsuguma

(10) **Patent No.:** **US D705,097 S**
(45) **Date of Patent:** **** May 20, 2014**

(54) **CONSTANT TEMPERATURE CHAMBER**

FOREIGN PATENT DOCUMENTS

- (71) Applicant: **Espec Corp.**, Osaka (JP)
- (72) Inventor: **Osamu Matsuguma**, Osaka (JP)
- (73) Assignee: **Espec Corp.**, Osaka (JP)
- (**) Term: **14 Years**

JP 2000-146821 A 5/2000

* cited by examiner

Primary Examiner — Antoine D Davis

(74) *Attorney, Agent, or Firm* — Birch, Stewart, Kolasch & Birch, LLP

(21) Appl. No.: **29/455,296**

(22) Filed: **May 20, 2013**

(30) **Foreign Application Priority Data**

Nov. 21, 2012 (JP) 2012-028528

(51) **LOC (10) Cl.** **10-04**

(52) **U.S. Cl.**
USPC **D10/52; D10/60**

(58) **Field of Classification Search**
USPC D10/52, 60; D24/232; 126/21 A;
165/47, 104.34; 324/750.13, 762.01
See application file for complete search history.

(56) **References Cited**

U.S. PATENT DOCUMENTS

- 5,859,540 A * 1/1999 Fukumoto 324/750.13
- 2011/0247782 A1 * 10/2011 Chou et al. 165/47

(57) **CLAIM**

The ornamental design for a constant temperature chamber, as shown and described.

DESCRIPTION

FIG. 1 is a perspective view of a constant temperature chamber;

FIG. 2 is a front view thereof;

FIG. 3 is a top view thereof;

FIG. 4 is a cross-sectional view thereof taken along line 4-4 in FIG. 2 wherein the internal mechanism is omitted; and,

FIG. 5 is an enlarged cross-sectional view taken along line 4-4 in FIG. 2 thereof.

The portion shown by broken lines is for illustrative purposes only and forms no part of the claimed design.

1 Claim, 5 Drawing Sheets

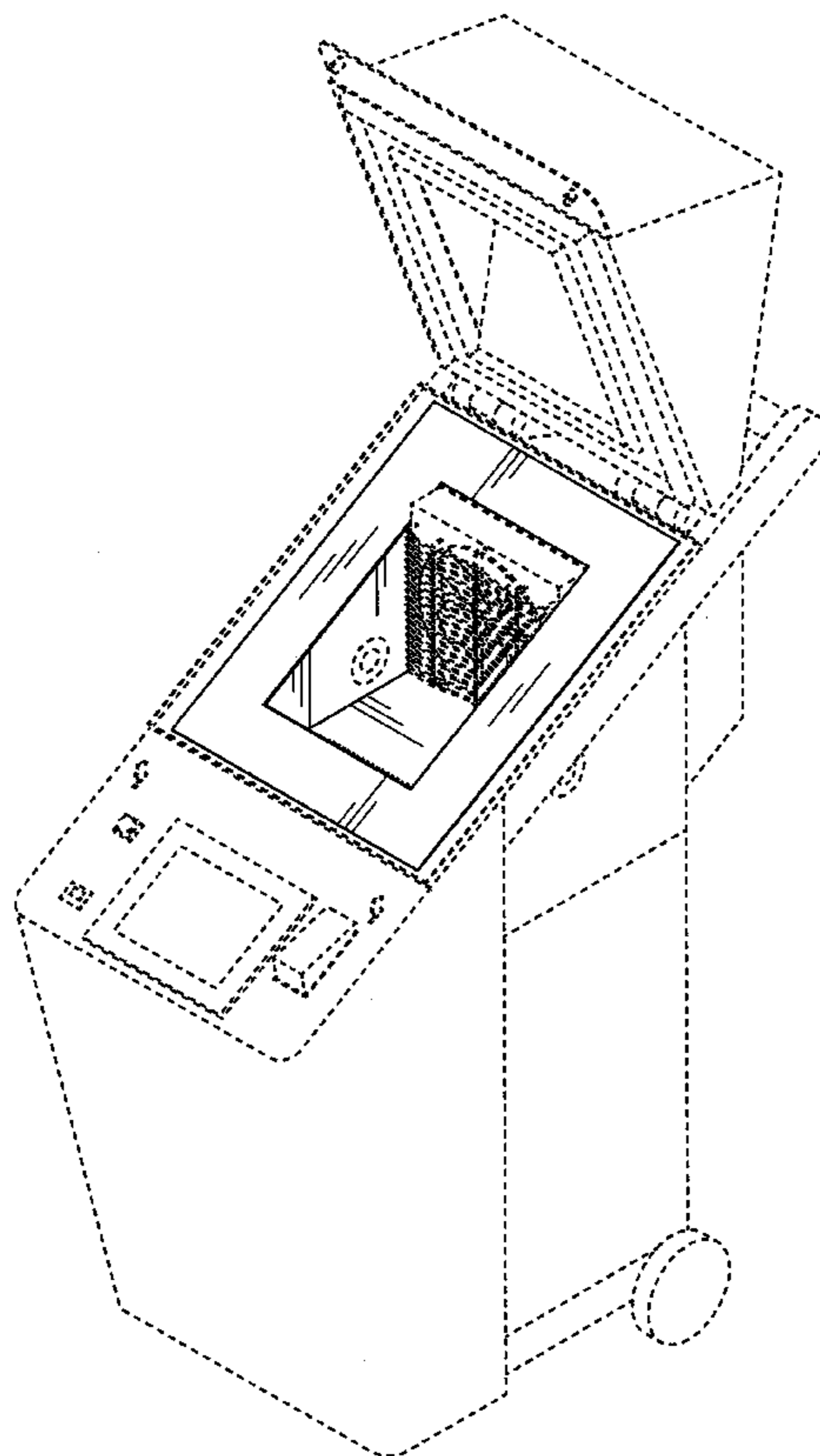

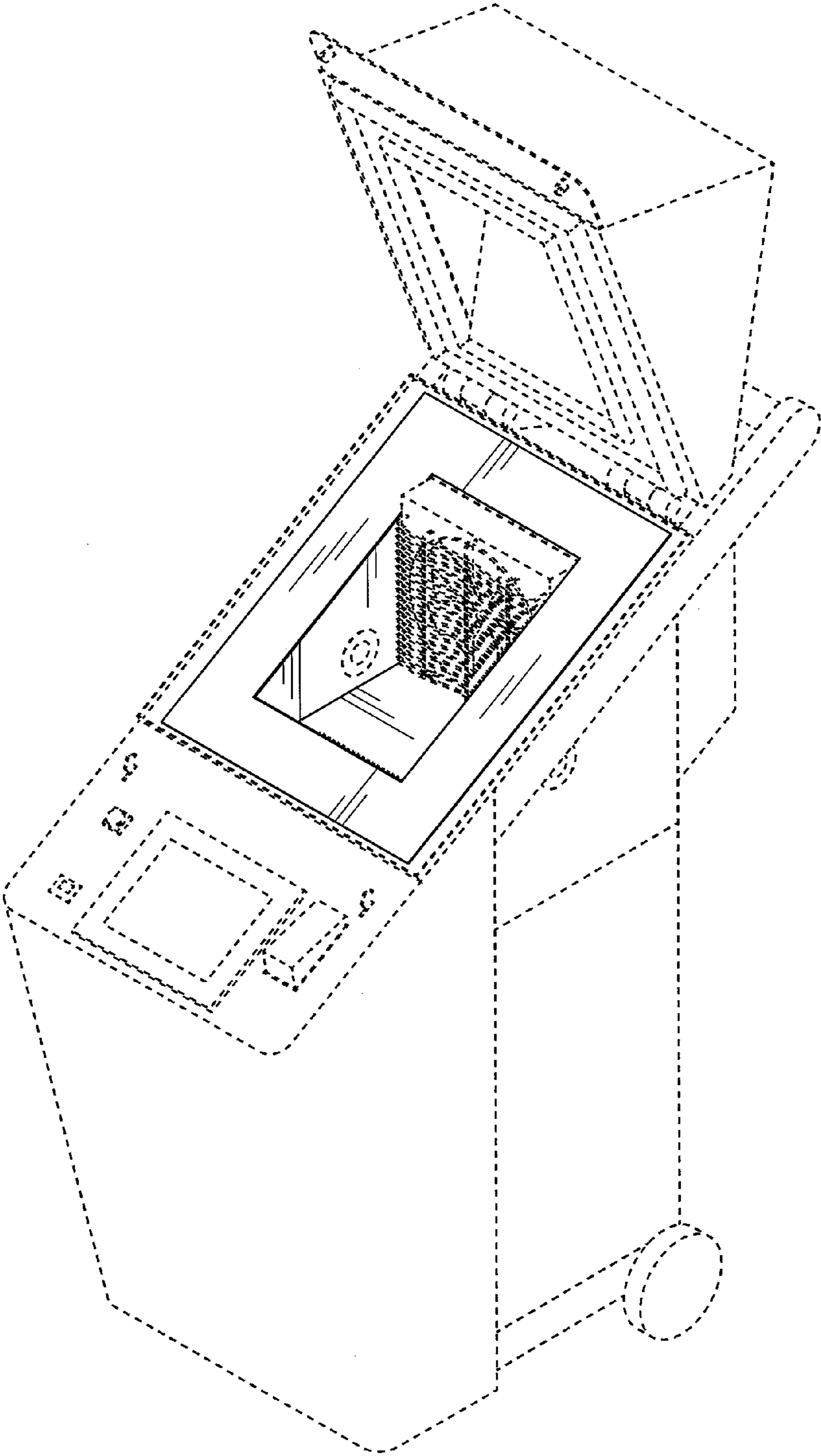

FIG.1

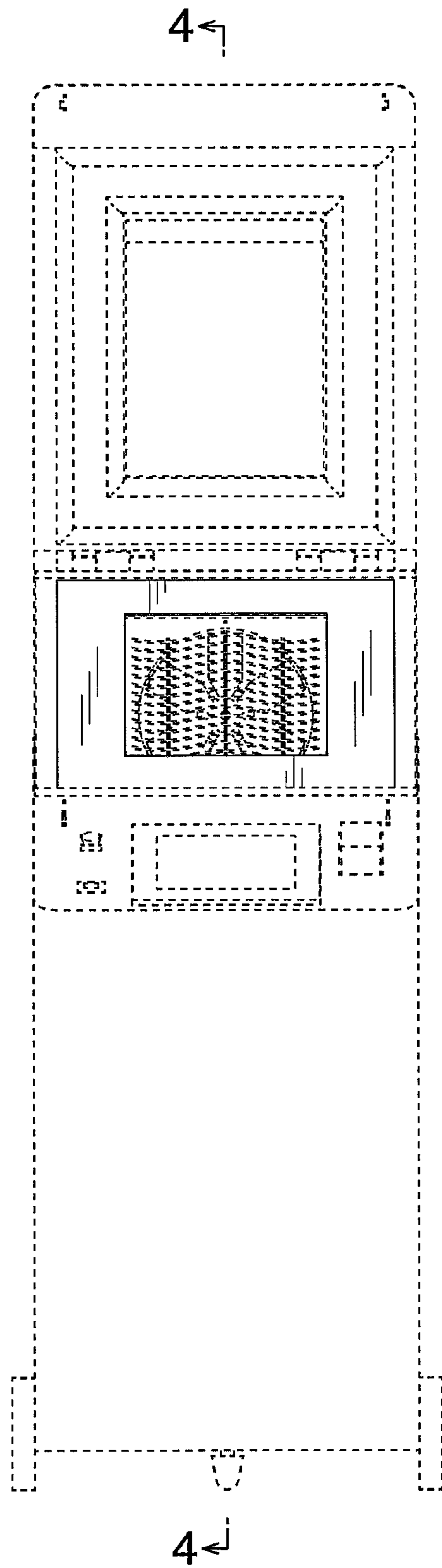

FIG.2

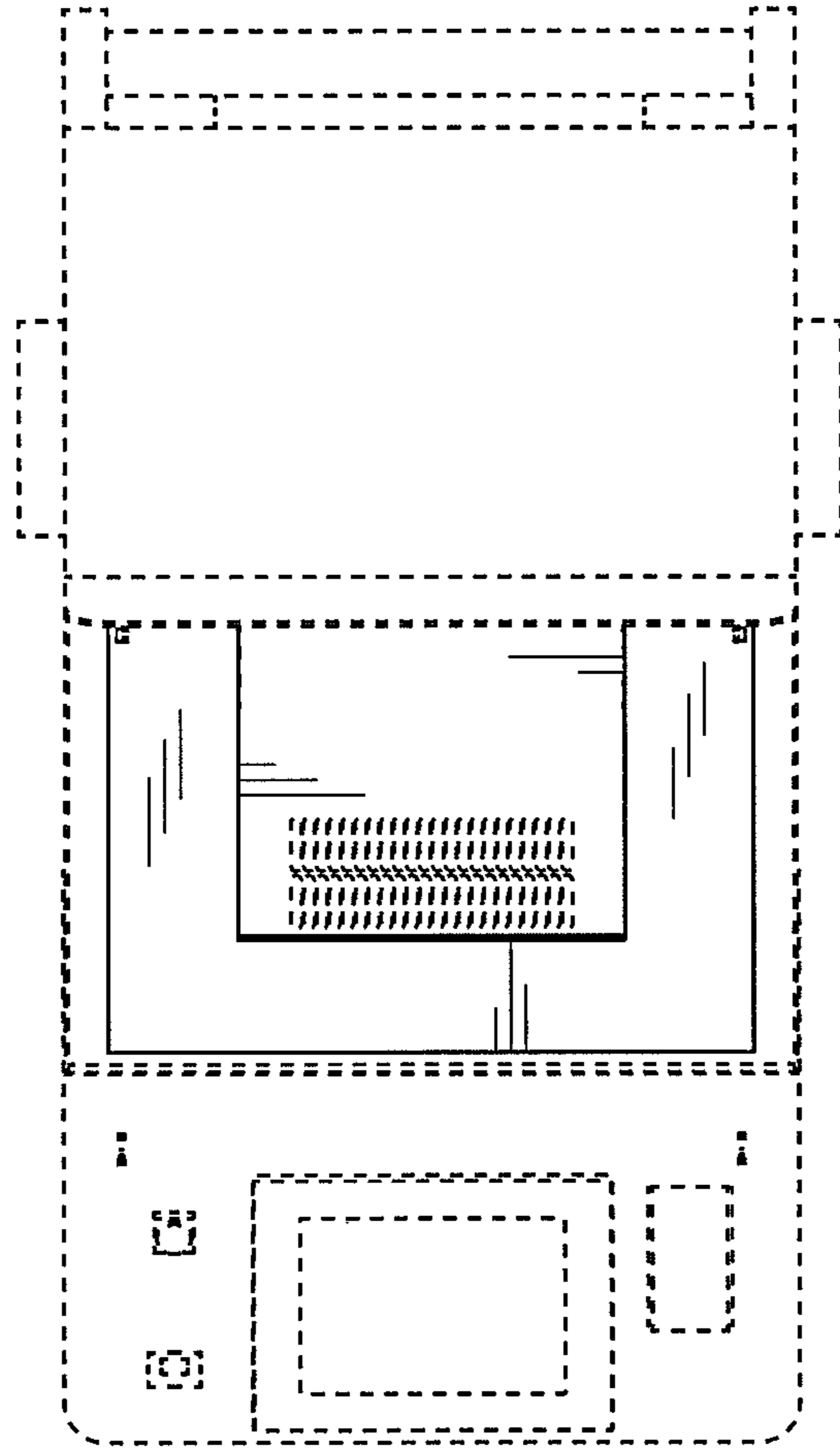

FIG.3

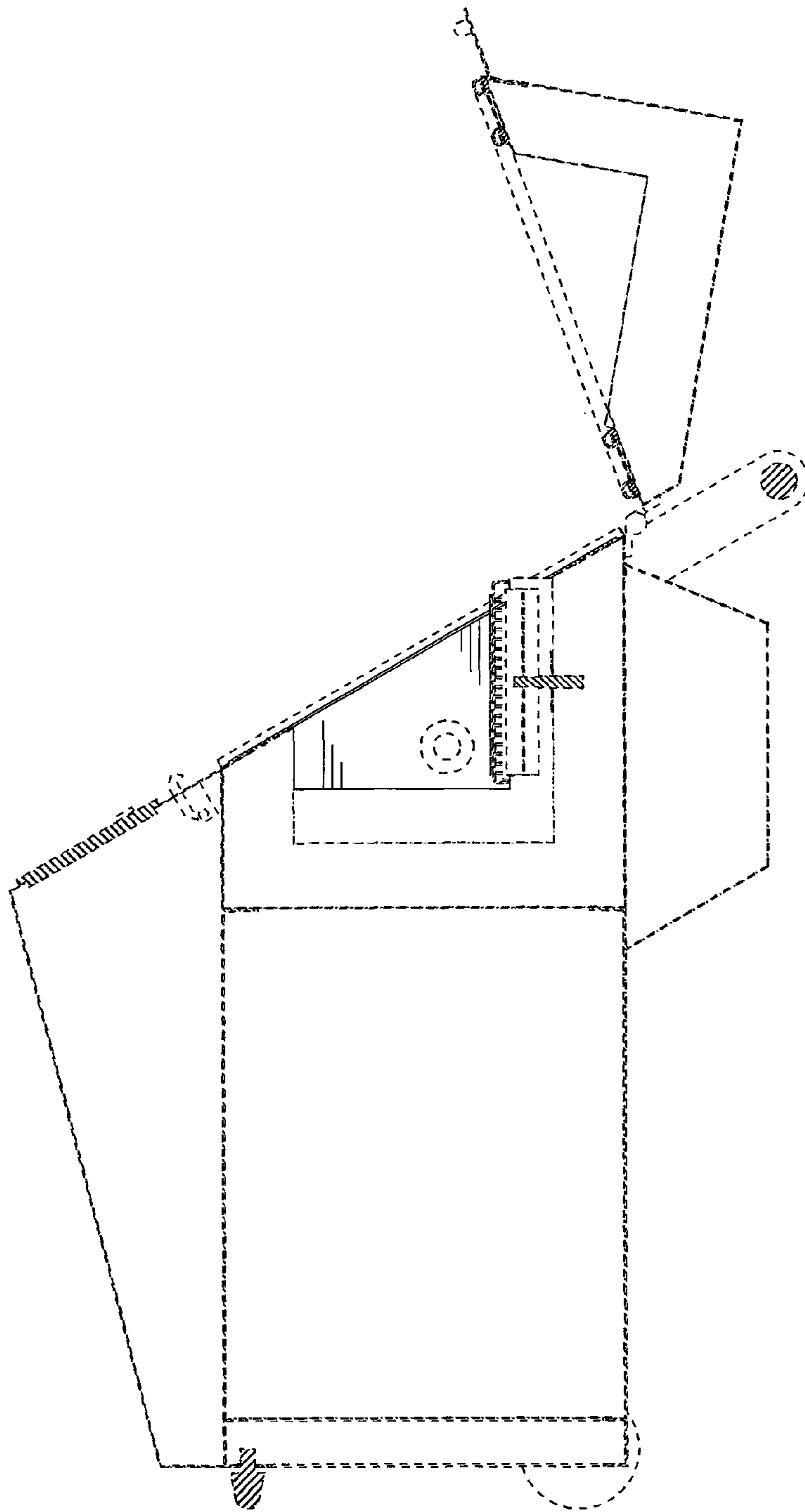

FIG. 4

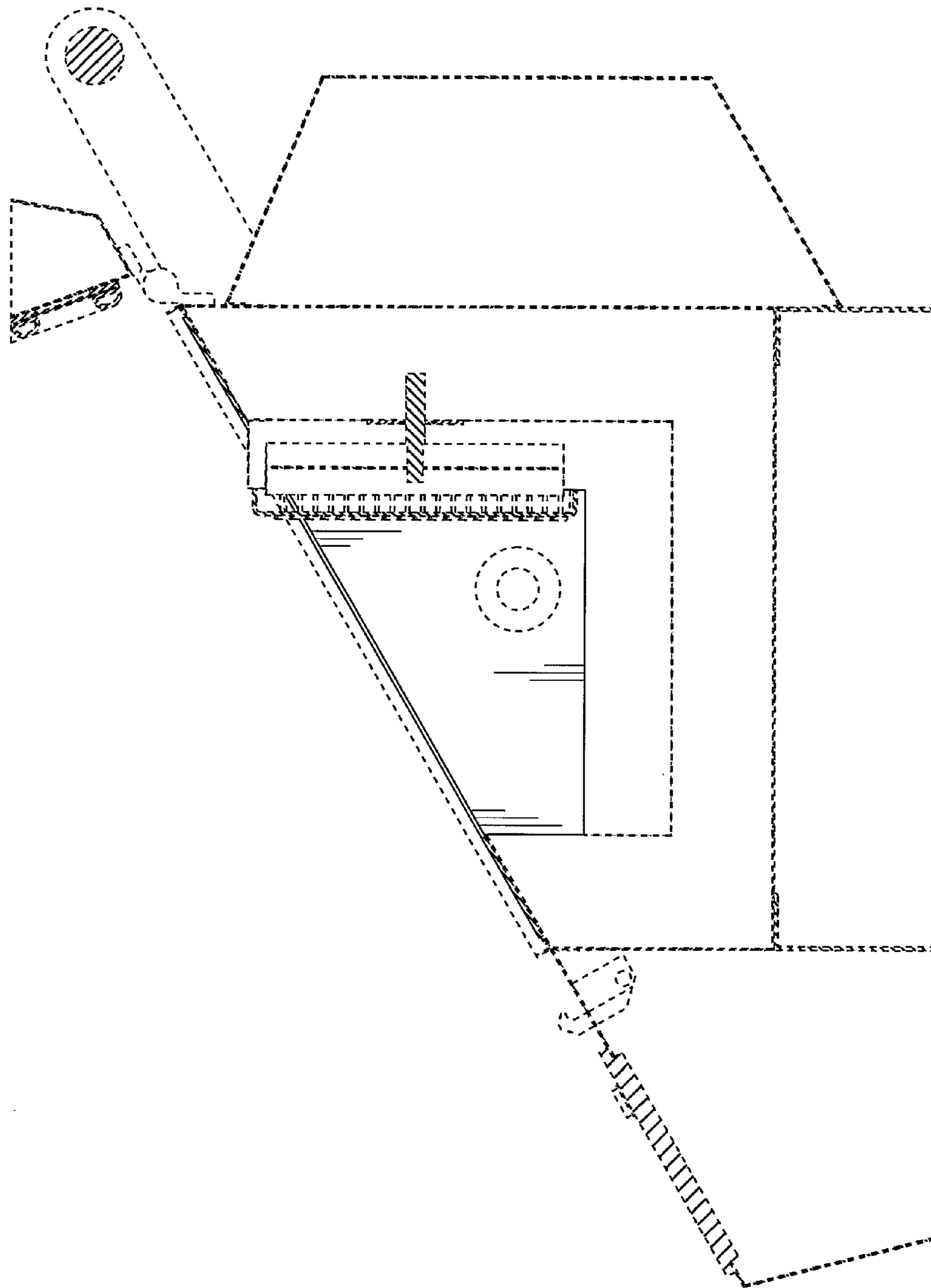

FIG.5