



US00D705008S

(12) **United States Design Patent**  
**Shin et al.**

(10) **Patent No.:** **US D705,008 S**

(45) **Date of Patent:** **\*\* May 20, 2014**

(54) **MICROWAVE OVEN**

(71) Applicant: **Samsung Electronics Co., Ltd.**,  
Gyeonggi-do (KR)

(72) Inventors: **Ji-Young Shin**, Seoul (KR); **Jaejun Kim**, Seoul (KR)

(73) Assignee: **Samsung Electronics Co., Ltd.**,  
Suwon-Si (KR)

(\*\*) Term: **14 Years**

(21) Appl. No.: **29/441,623**

(22) Filed: **Jan. 8, 2013**

(30) **Foreign Application Priority Data**

Aug. 28, 2012 (KR) ..... 30-2012-0041320

(51) **LOC (10) CL.** ..... **07-02**

(52) **U.S. Cl.**  
USPC ..... **D7/405**

(58) **Field of Classification Search**  
USPC ..... D7/350.1, 350.3, 350.4, 351, 402, 405,  
D7/406; 219/756-758; 126/19 M, 21 A,  
126/275 E

See application file for complete search history.

(56) **References Cited**

**U.S. PATENT DOCUMENTS**

D294,108 S \* 2/1988 Choi ..... D7/351  
D302,927 S \* 8/1989 Yoshida ..... D7/351  
D329,353 S \* 9/1992 Yamada ..... D7/351

D439,468 S \* 3/2001 Kim ..... D7/351  
D442,820 S \* 5/2001 Kim ..... D7/351  
D531,447 S \* 11/2006 Lee et al. .... D7/350.4  
D532,645 S \* 11/2006 Lee ..... D7/351  
D540,105 S \* 4/2007 Lee et al. .... D7/351  
D545,611 S \* 7/2007 Sakata ..... D7/351  
D550,024 S \* 9/2007 Jeon ..... D7/350.1  
D583,614 S \* 12/2008 Chung et al. .... D7/351  
D599,163 S \* 9/2009 Oomae ..... D7/351  
D632,125 S \* 2/2011 Kim et al. .... D7/351  
D633,328 S \* 3/2011 Shin ..... D7/351  
D633,329 S \* 3/2011 Baek et al. .... D7/351  
D633,330 S \* 3/2011 Baek et al. .... D7/351  
D634,576 S \* 3/2011 Baek et al. .... D7/351  
D673,418 S \* 1/2013 Lee et al. .... D7/351

\* cited by examiner

*Primary Examiner* — Ruth McInroy

(74) *Attorney, Agent, or Firm* — Ladas & Parry LLP

(57) **CLAIM**

We claim the ornamental design for a microwave oven, as shown and described.

**DESCRIPTION**

FIG. 1 is a top, front and right-side perspective view of a microwave oven showing our new design; FIG. 2 is a front elevational view thereof; FIG. 3 is a rear elevational view thereof; FIG. 4 is a left-side elevational view thereof; FIG. 5 is a right-side elevational view thereof; FIG. 6 is a top plan view thereof; and, FIG. 7 is a bottom plan view thereof.

The details shown in broken lines form no part of the claimed design.

**1 Claim, 7 Drawing Sheets**

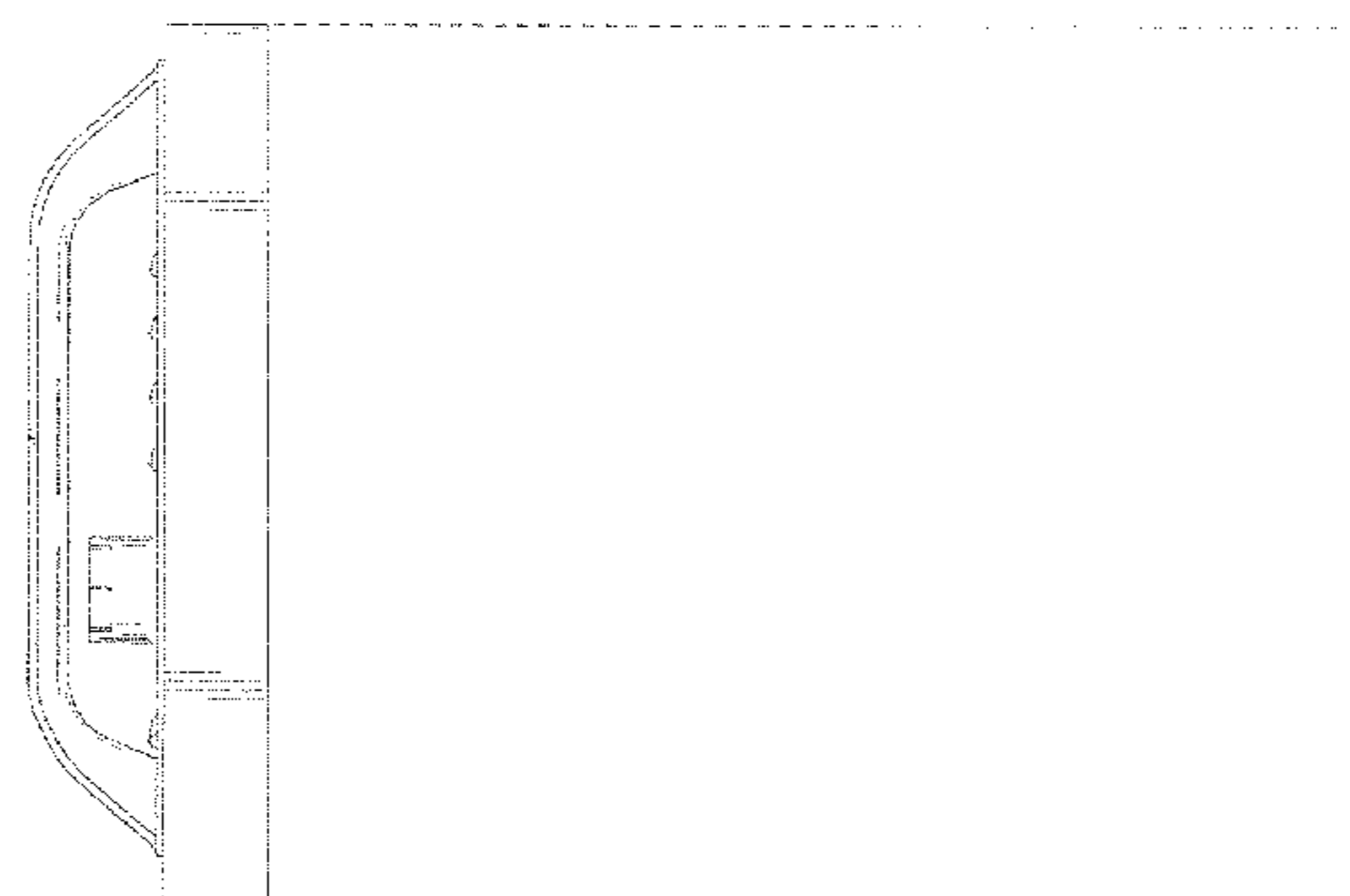
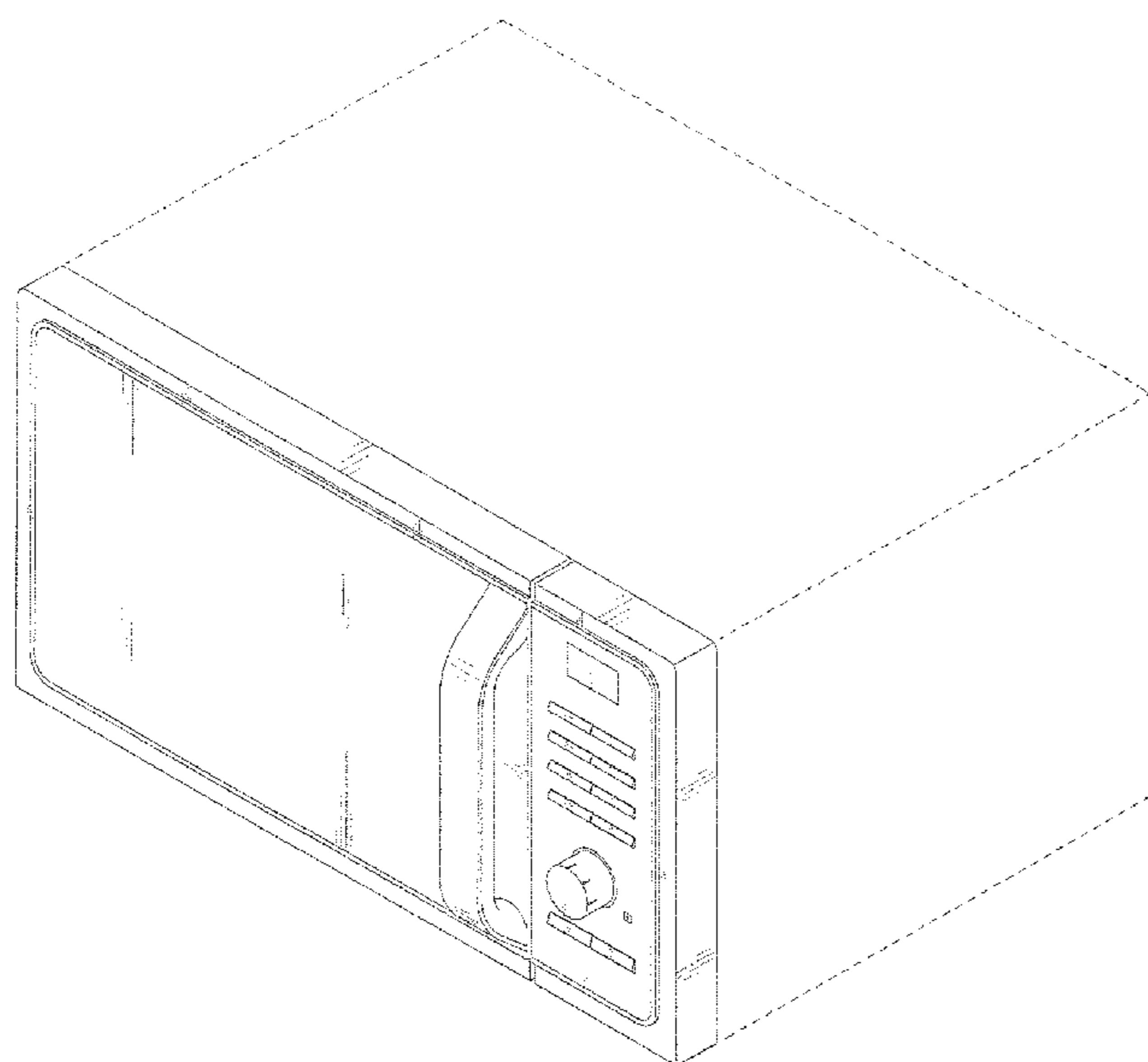

Fig. 1

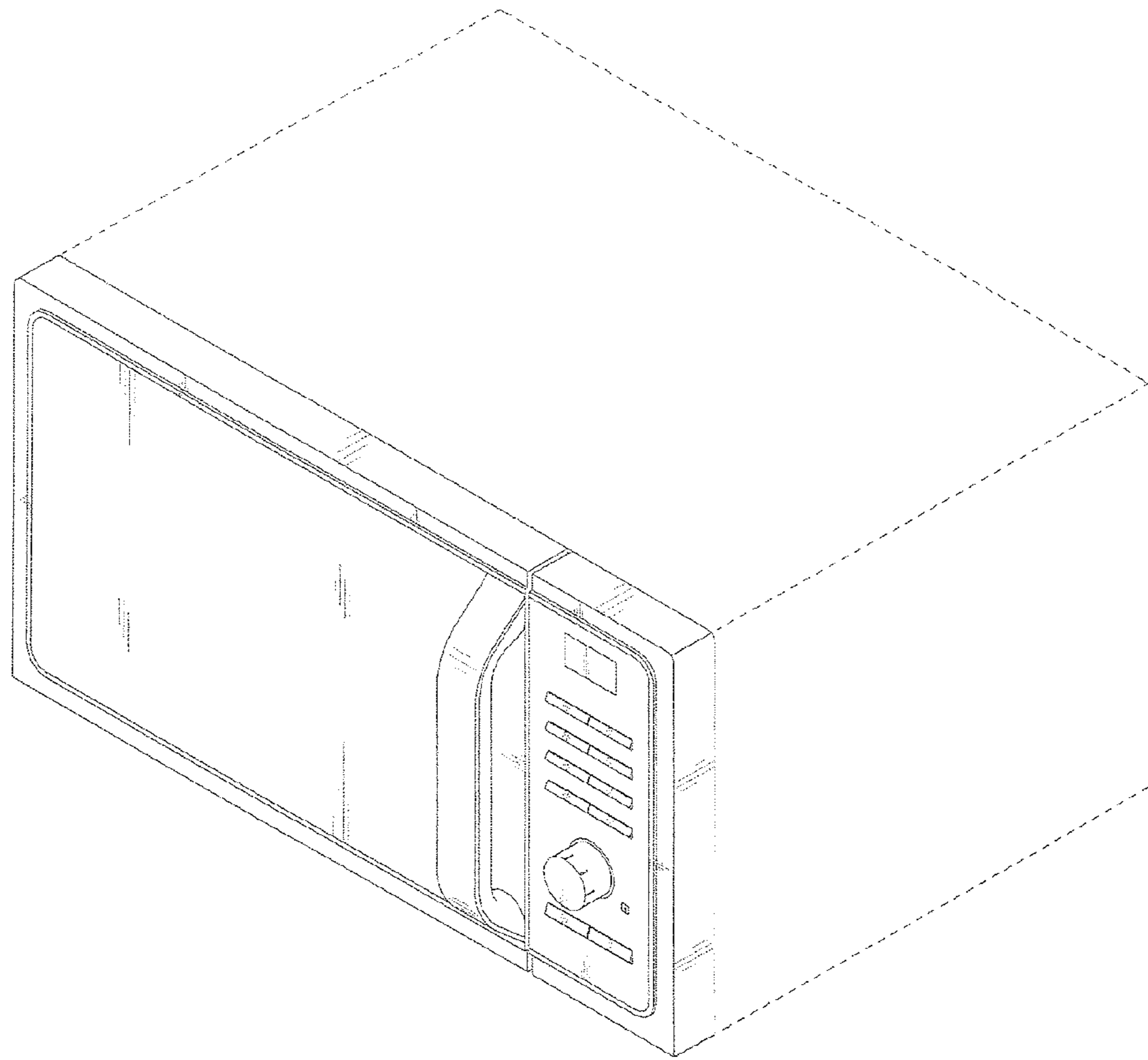

Fig. 2

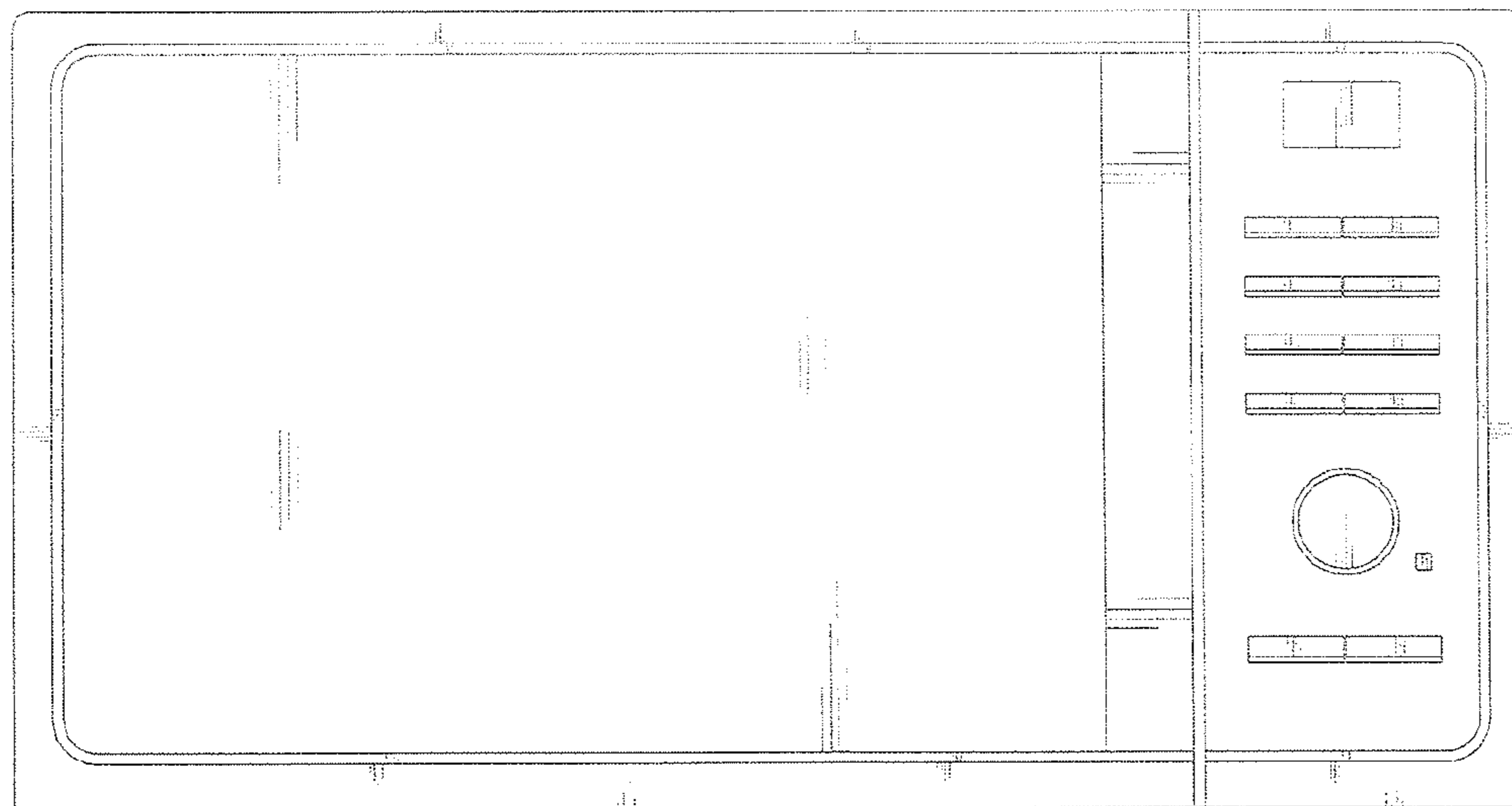

Fig. 3

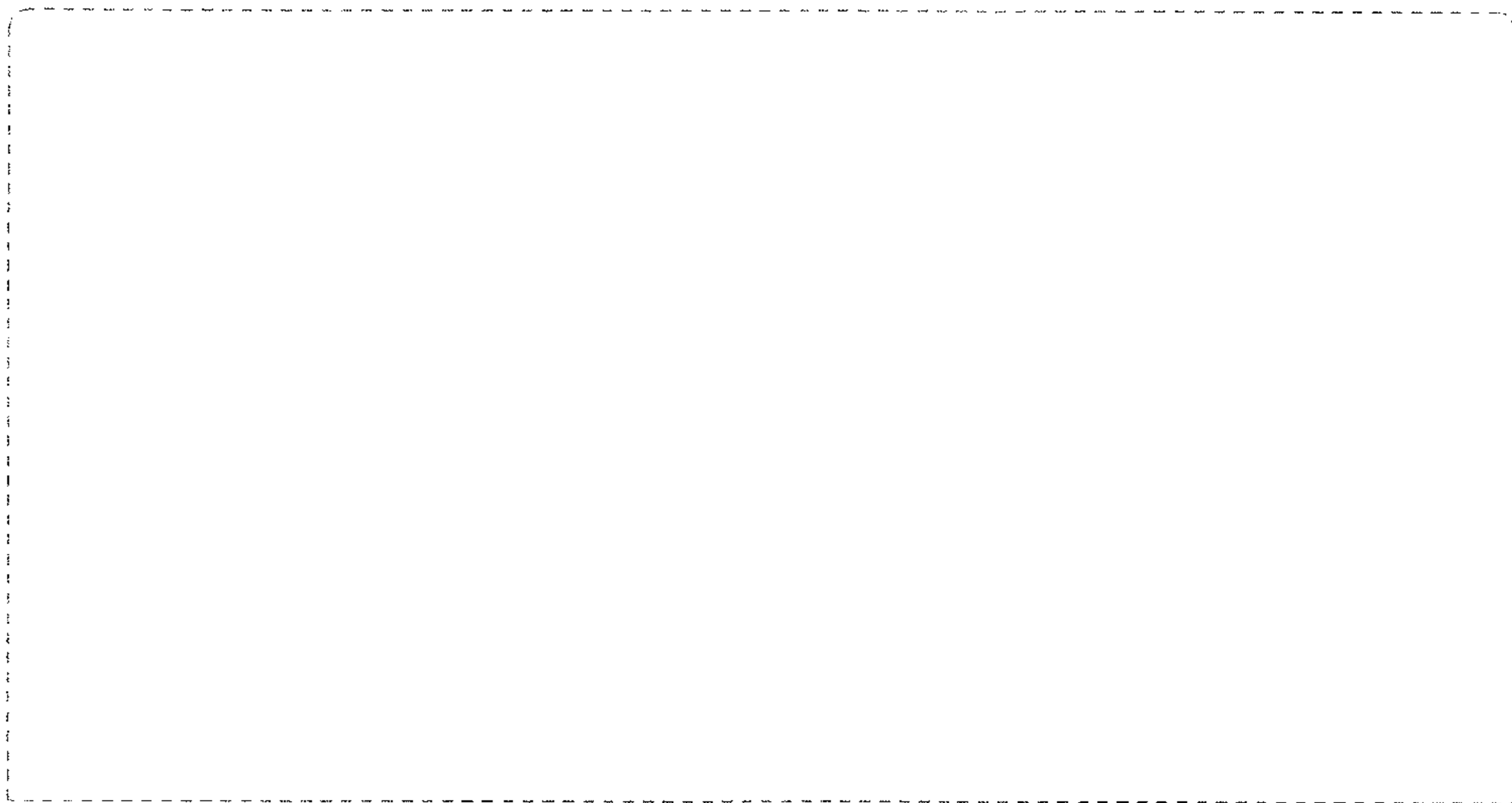

Fig. 4

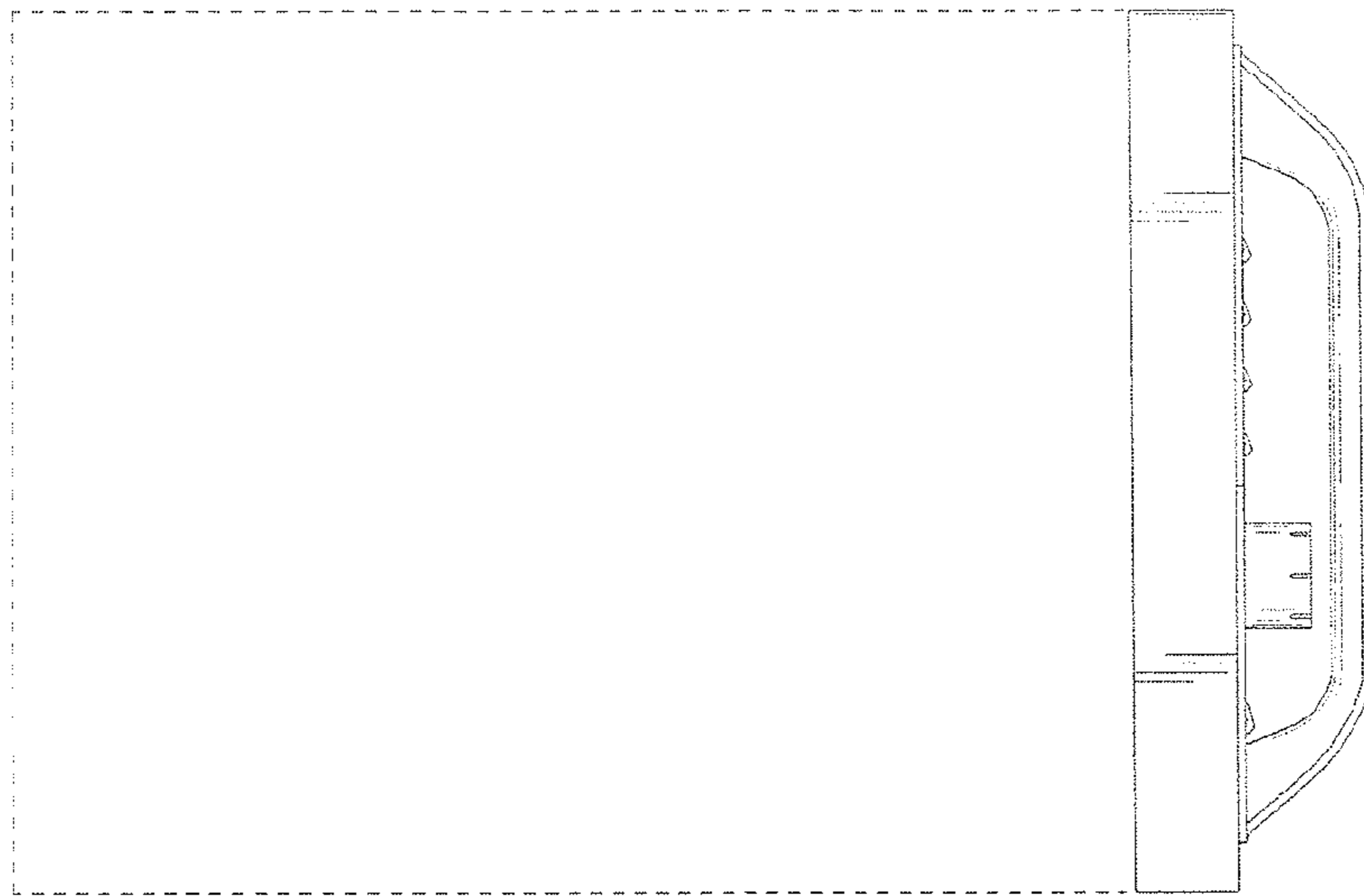

Fig. 5

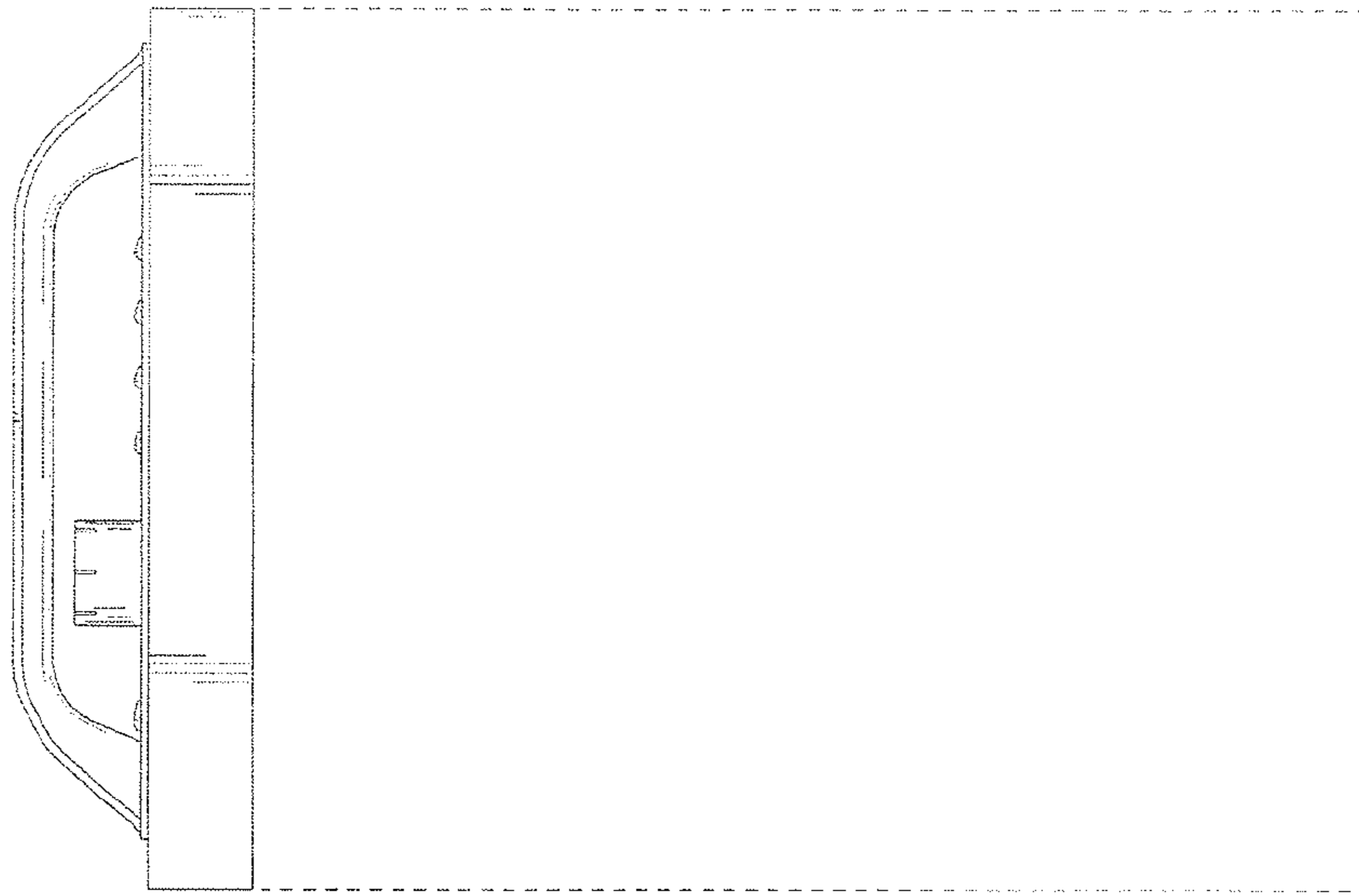

Fig. 6



Fig. 7

