



US00D704877S

(12) **United States Design Patent**
Szoke

(10) **Patent No.:** **US D704,877 S**

(45) **Date of Patent:** **** May 13, 2014**

(54) **LED LIGHT FIXTURE**

(71) Applicant: **Steve Szoke**, West Hempstead, NY (US)

(72) Inventor: **Steve Szoke**, West Hempstead, NY (US)

(**) Term: **14 Years**

(21) Appl. No.: **29/442,814**

(22) Filed: **May 22, 2013**

(51) **LOC (10) Cl.** **26-03**

(52) **U.S. Cl.**
USPC **D26/76**

(58) **Field of Classification Search**
USPC D26/72, 75-78, 118, 120, 122;
362/147, 217.01-217.12, 218,
362/221-225, 345

See application file for complete search history.

(56) **References Cited**

U.S. PATENT DOCUMENTS

D118,515 S *	1/1940	Summerour	D26/77
D122,582 S *	9/1940	Biller	D26/76
D127,397 S *	5/1941	Johnston	D26/76
D180,533 S *	6/1957	Stevens	D26/76
D180,534 S *	6/1957	Stevens	D26/76
D195,529 S *	6/1963	Florence	D26/76
D198,183 S *	5/1964	Akely	D26/71
D327,956 S *	7/1992	Dieperink	D26/77
D334,821 S *	4/1993	Morgan	D26/28

D335,191 S *	4/1993	Morgan	D26/28
D405,908 S *	2/1999	Herst et al.	D26/76
D446,333 S *	8/2001	Frois	D26/76
D452,030 S *	12/2001	Collver	D26/76
D520,172 S *	5/2006	Engel	D26/76
D543,651 S *	5/2007	Hargreaves	D26/76
D544,129 S *	6/2007	Hargreaves	D26/76
D544,980 S *	6/2007	Hargreaves	D26/76
D591,444 S *	4/2009	Beno et al.	D26/88
D595,443 S *	6/2009	Tran et al.	D26/76
D645,194 S *	9/2011	Budike et al.	D26/76
2010/0315813 A1 *	12/2010	Fugerer et al.	362/249.02

* cited by examiner

Primary Examiner — Clare E Heflin

(57) **CLAIM**

The ornamental design for the LED light fixture, as shown and described.

DESCRIPTION

FIG. 1 is a perspective view of the LED light fixture showing my new design;
FIG. 2 is a perspective view thereof;
FIG. 3 is a top plan view thereof;
FIG. 4 is a front elevational view thereof;
FIG. 5 is a bottom view thereof;
FIG. 6. is a right elevational view thereof; and,
FIG. 7 is a left elevational view thereof.

1 Claim, 2 Drawing Sheets

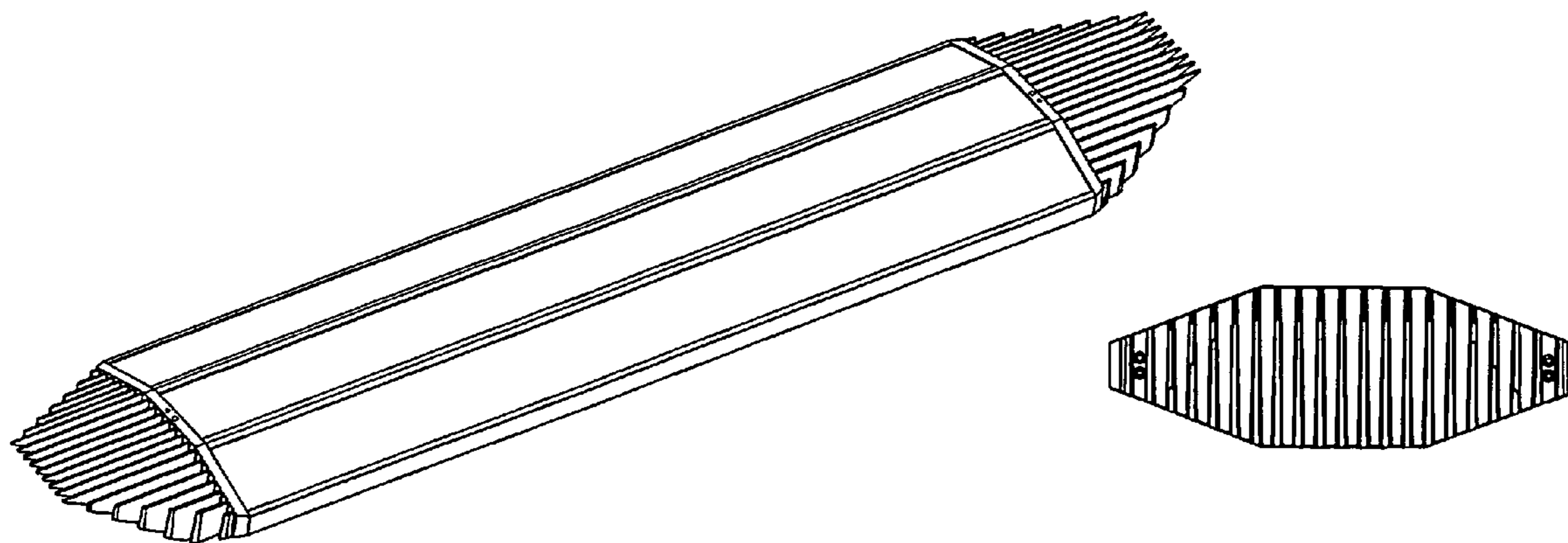

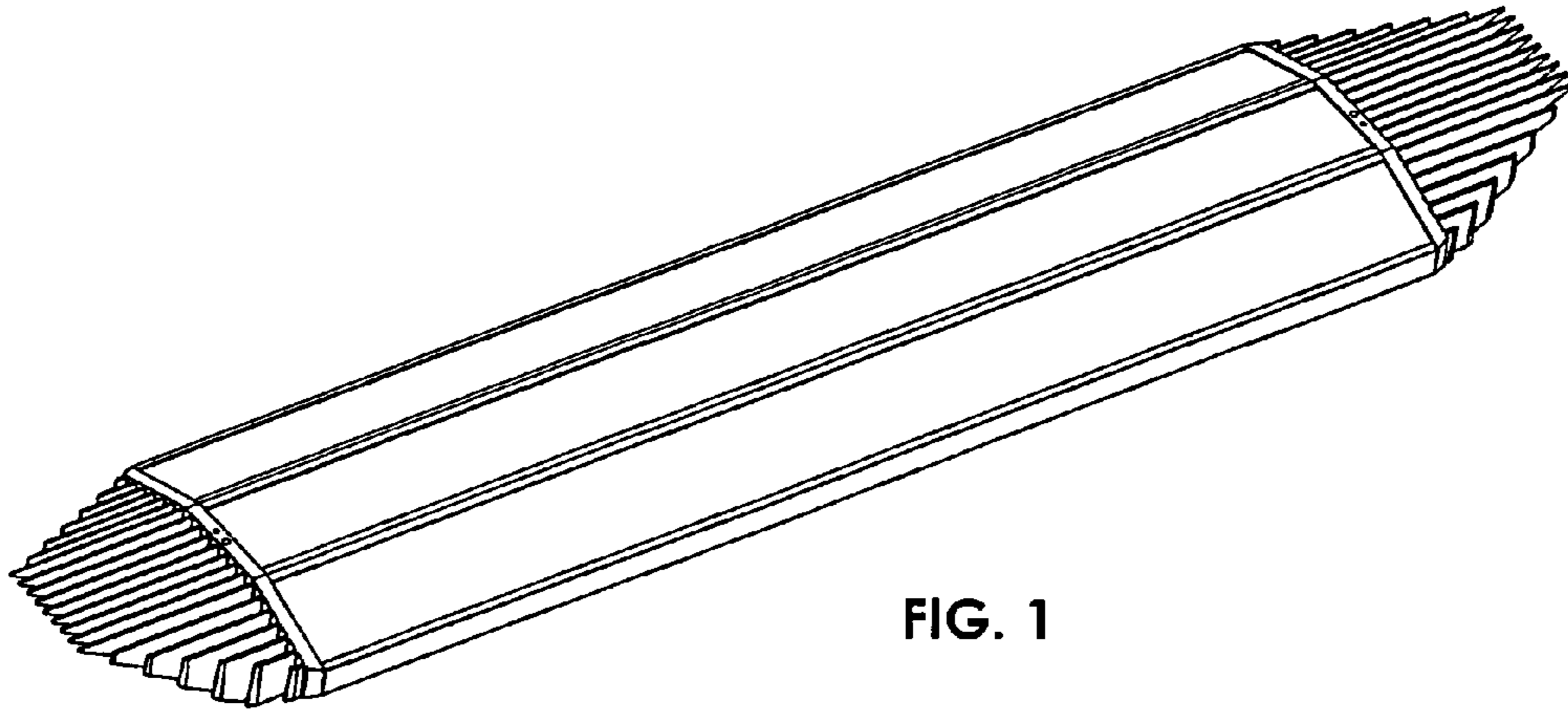

FIG. 1

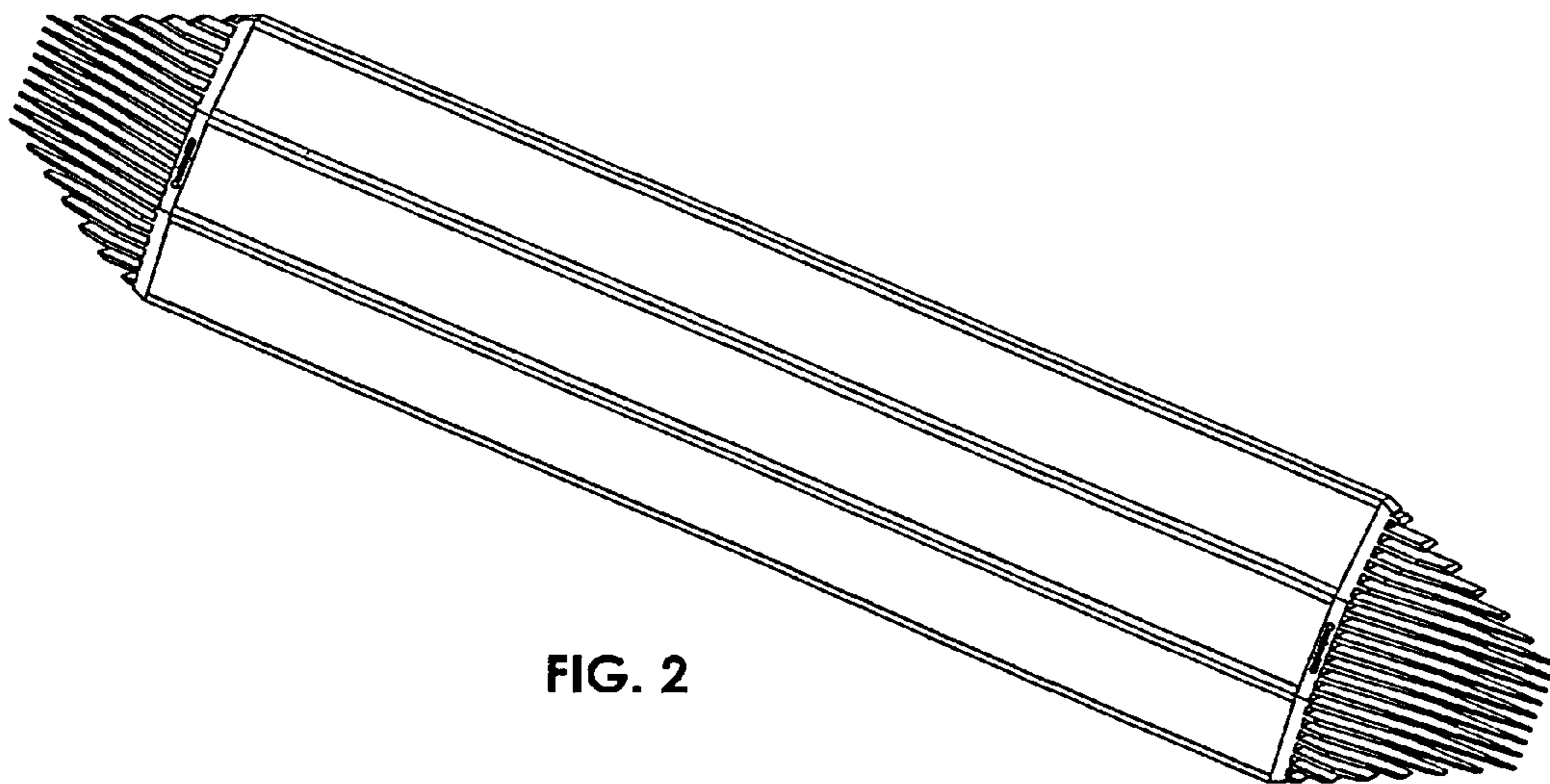

FIG. 2

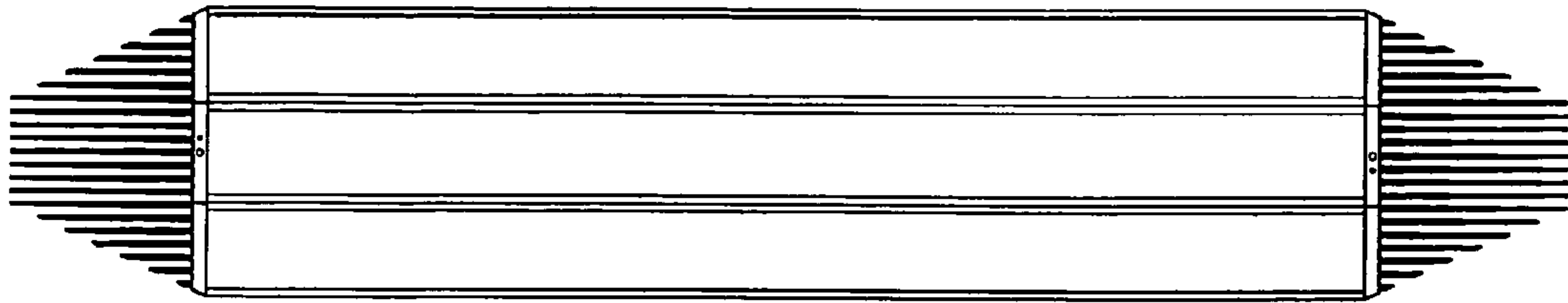

FIG. 3

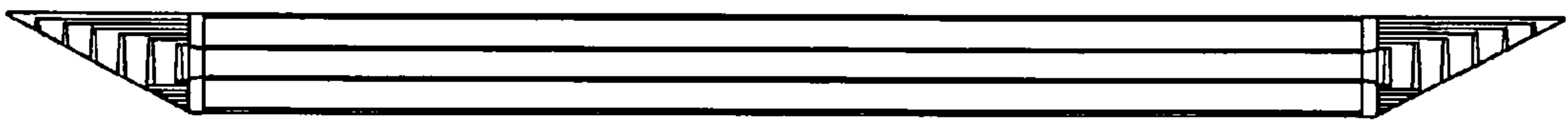

FIG. 4

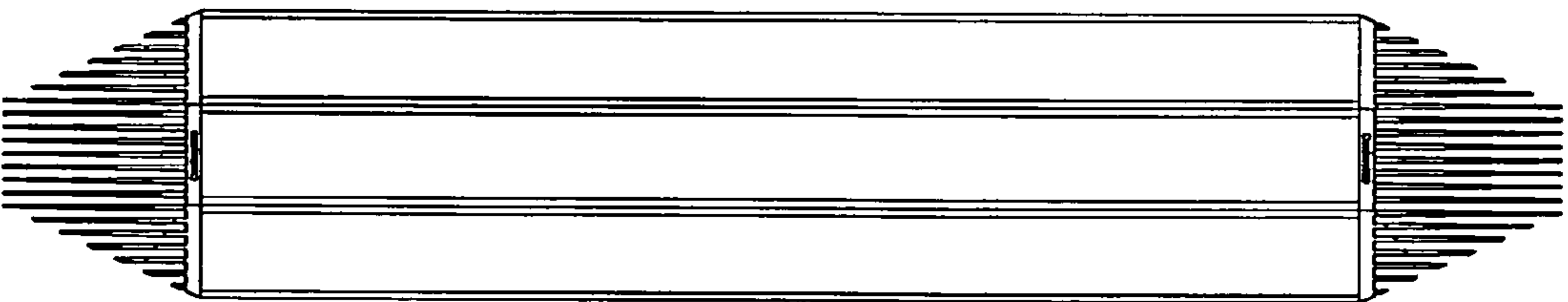

FIG. 5

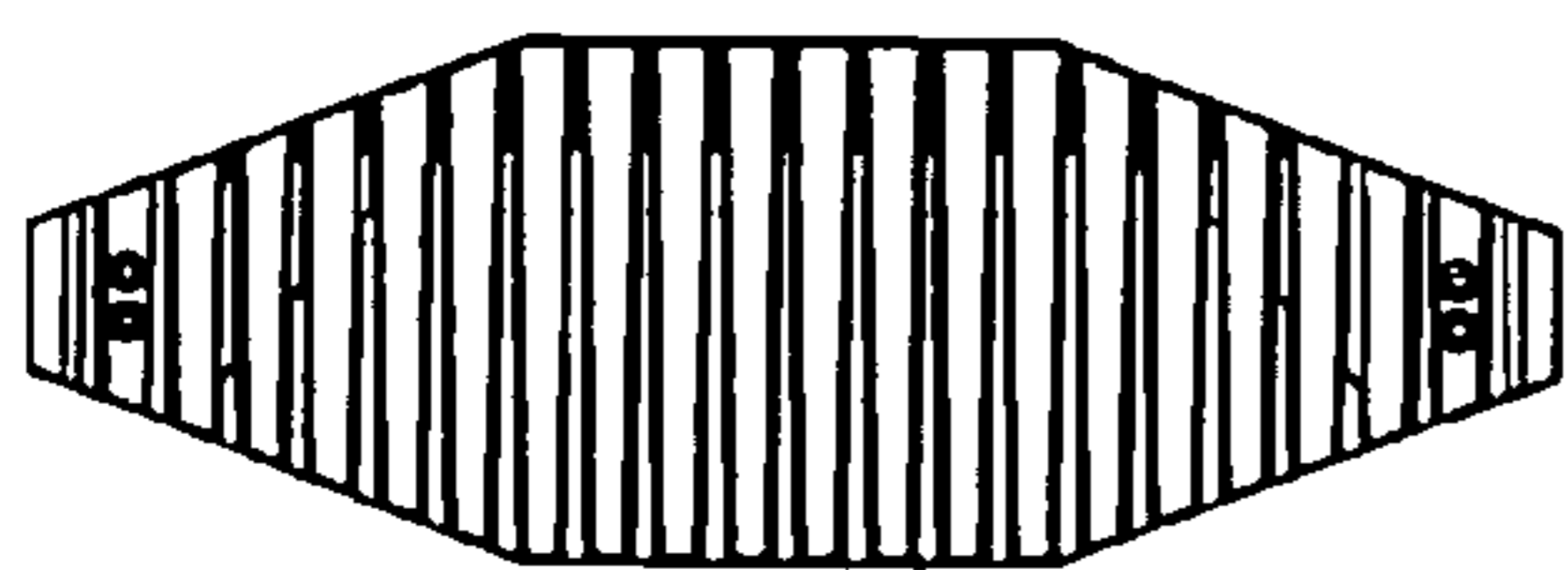

FIG. 6

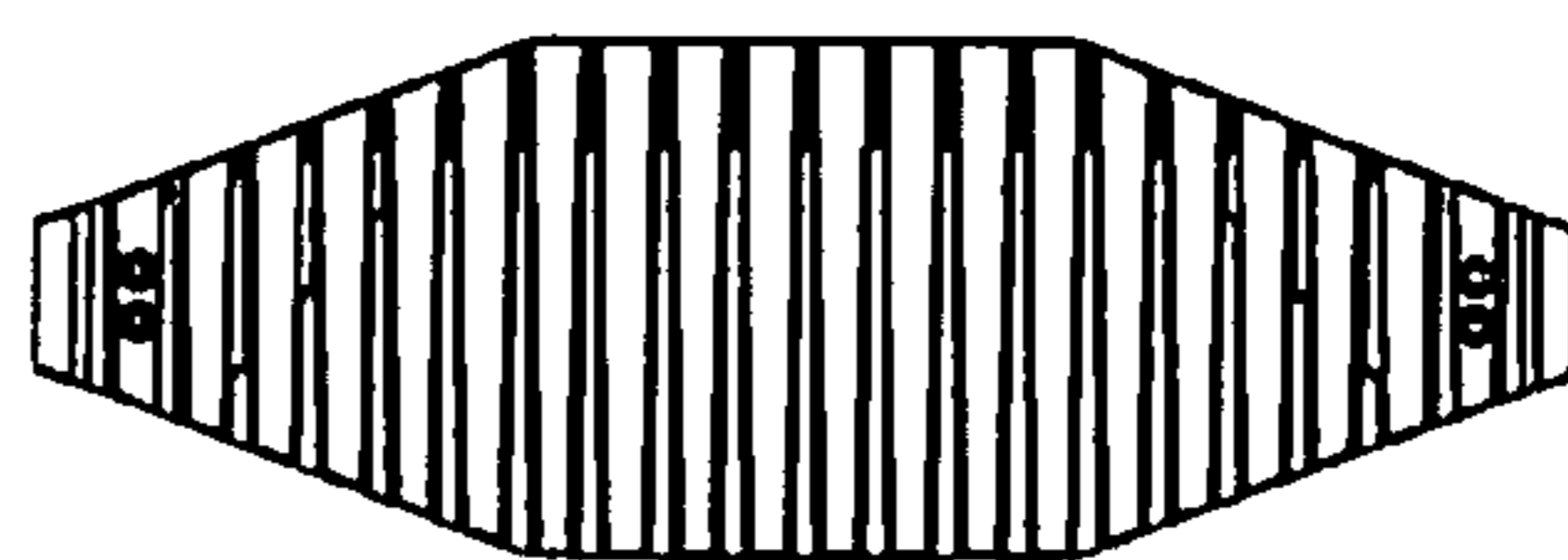

FIG. 7