



US00D704365S

(12) **United States Design Patent**  
**Adams**

(10) **Patent No.:** **US D704,365 S**

(45) **Date of Patent:** **\*\* May 6, 2014**

(54) **VEHICLE LIGHT**

(75) Inventor: **Stephen P Adams**, Mesa, AZ (US)

(73) Assignee: **JST Performance, Inc.**, Gilbert, AZ (US)

(\*\*) Term: **14 Years**

(21) Appl. No.: **29/415,065**

(22) Filed: **Mar. 7, 2012**

(51) **LOC (10) Cl.** ..... **26-06**

(52) **U.S. Cl.**  
USPC ..... **D26/28**

(58) **Field of Classification Search**  
USPC ..... D26/28-36; 362/459-468, 475-478,  
362/485-487

See application file for complete search history.

(56) **References Cited**

**U.S. PATENT DOCUMENTS**

D490,172 S \* 5/2004 Yamamoto ..... D26/28  
D554,279 S \* 10/2007 Jeffries ..... D26/28  
D564,683 S \* 3/2008 Roach et al. .... D26/28

D570,009 S \* 5/2008 Kani et al. .... D26/28  
D574,978 S \* 8/2008 Hyodo et al. .... D26/28  
D688,399 S \* 8/2013 Adams ..... D26/28

\* cited by examiner

*Primary Examiner* — Marcus Jackson

(57) **CLAIM**

The ornamental design for a vehicle light, as shown and described.

**DESCRIPTION**

FIG. 1 is a front right perspective view of a vehicle light embodying the new design;  
FIG. 2 is a rear right perspective view;  
FIG. 3 is a front elevational view;  
FIG. 4 is a rear elevational view;  
FIG. 5 is a left side elevational view;  
FIG. 6 is a right side elevational view;  
FIG. 7 is a top view; and,  
FIG. 8 is a bottom view.

The broken line representation of the power cord is for purposes of illustration, and forms no part of the claimed design.

**1 Claim, 4 Drawing Sheets**

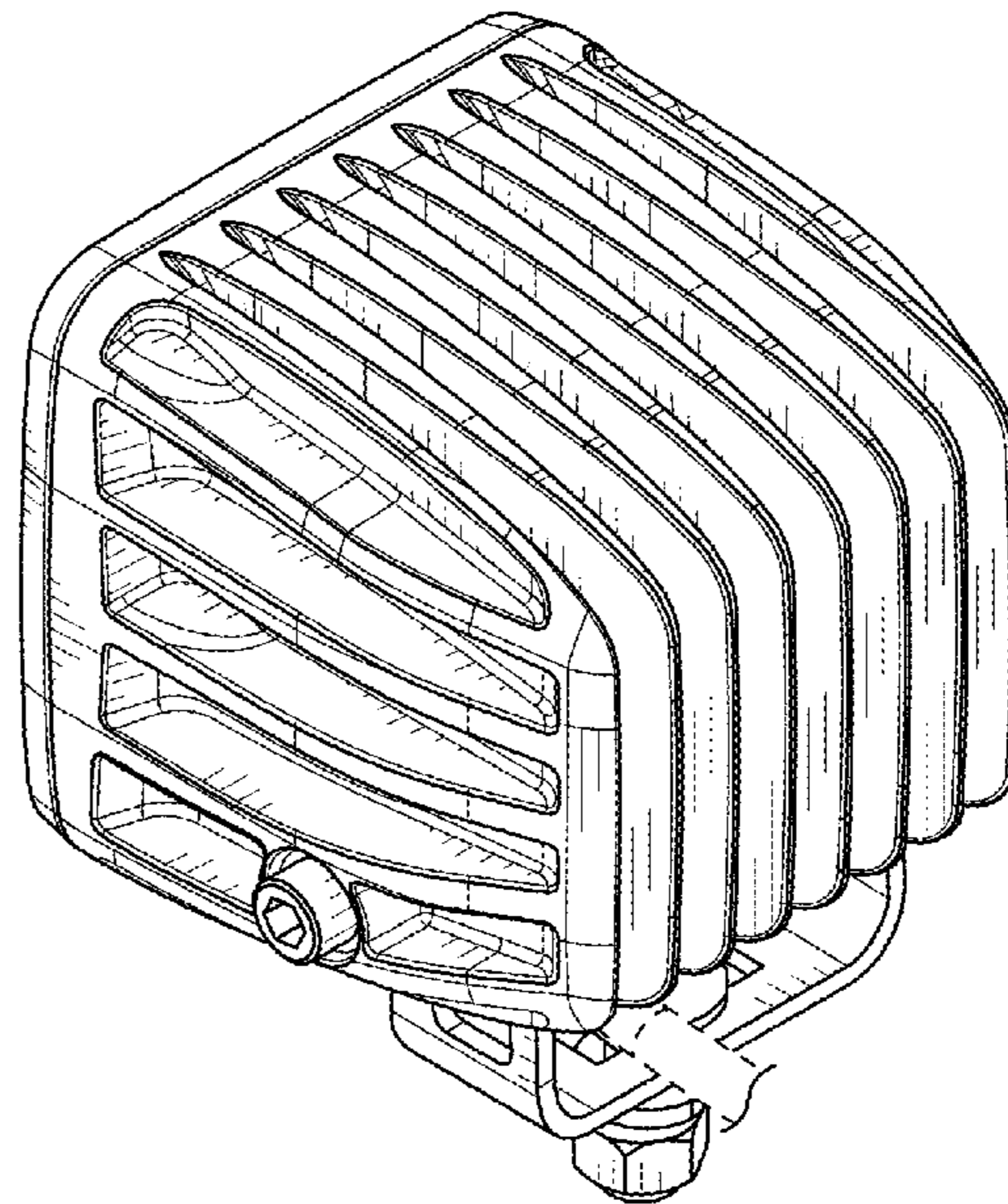
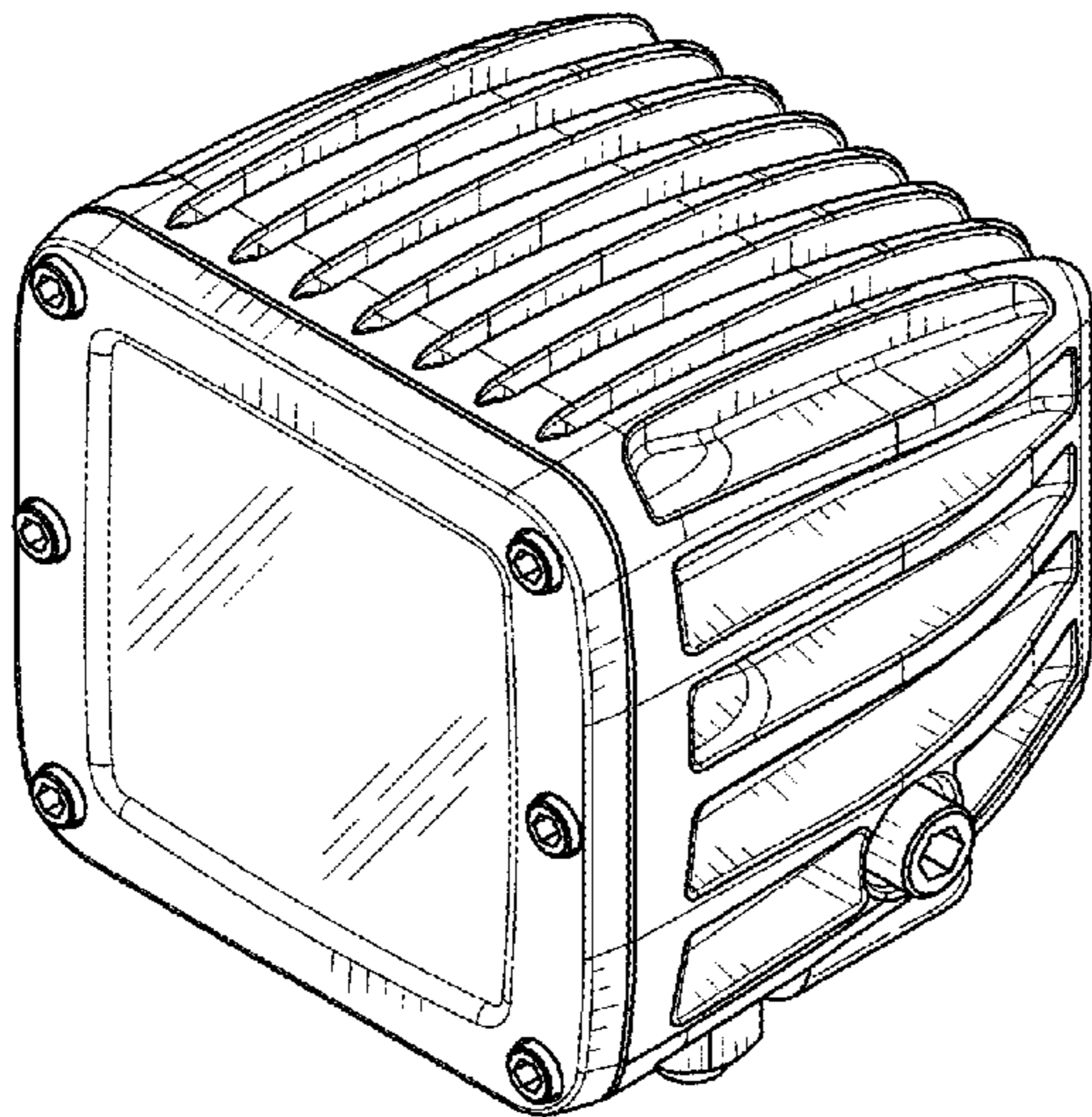

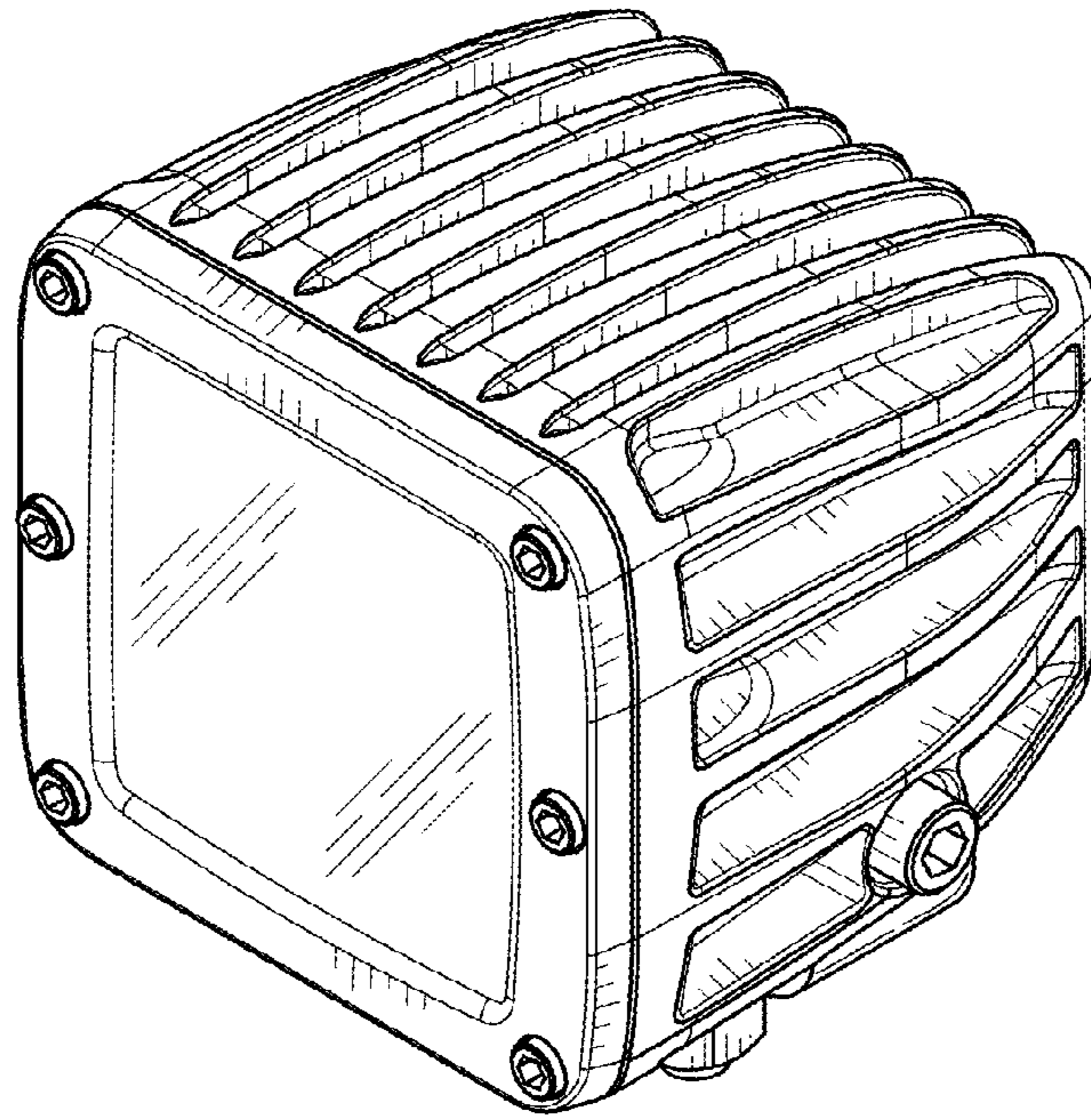

FIG. 1

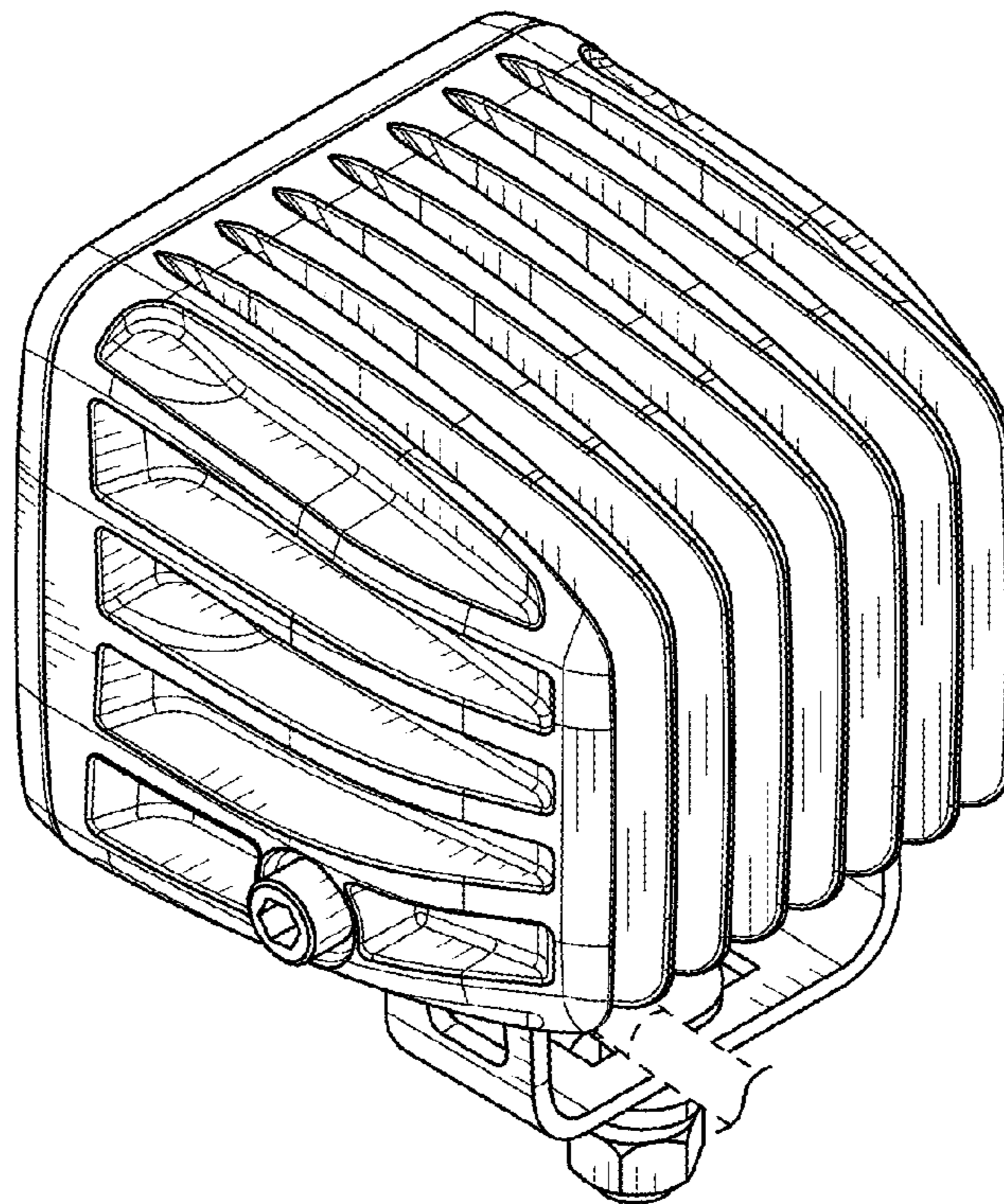

FIG. 2

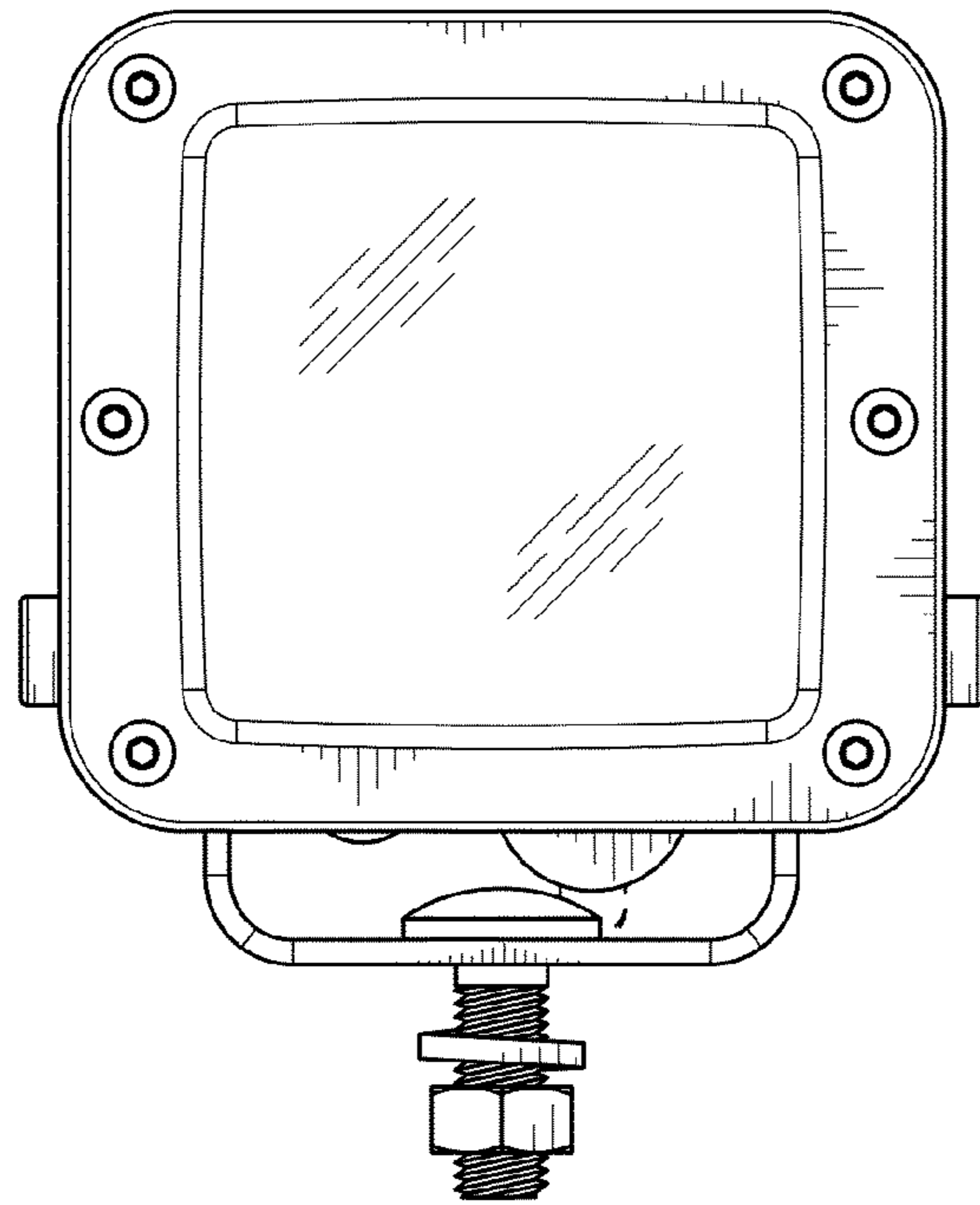

FIG. 3

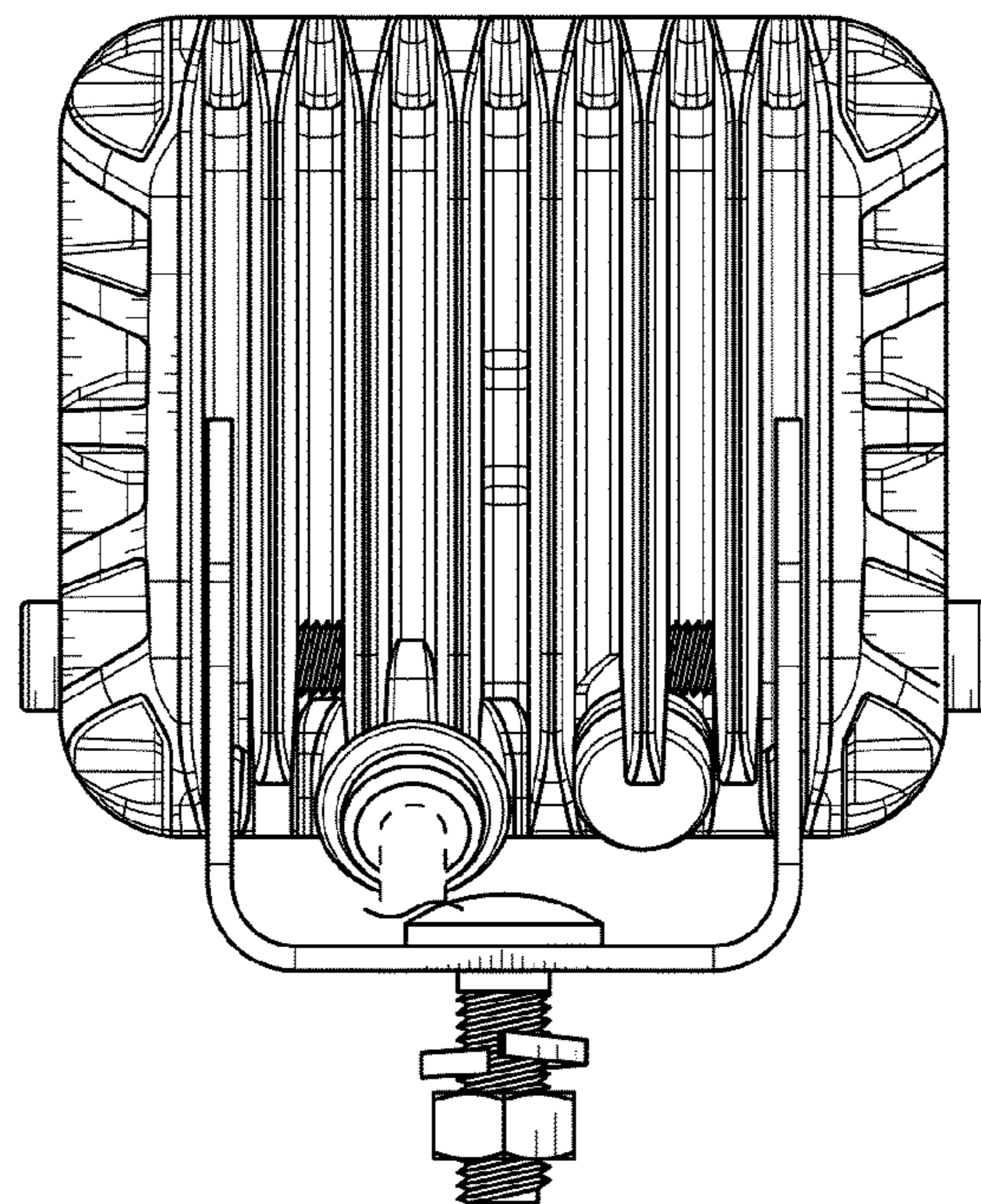

FIG. 4

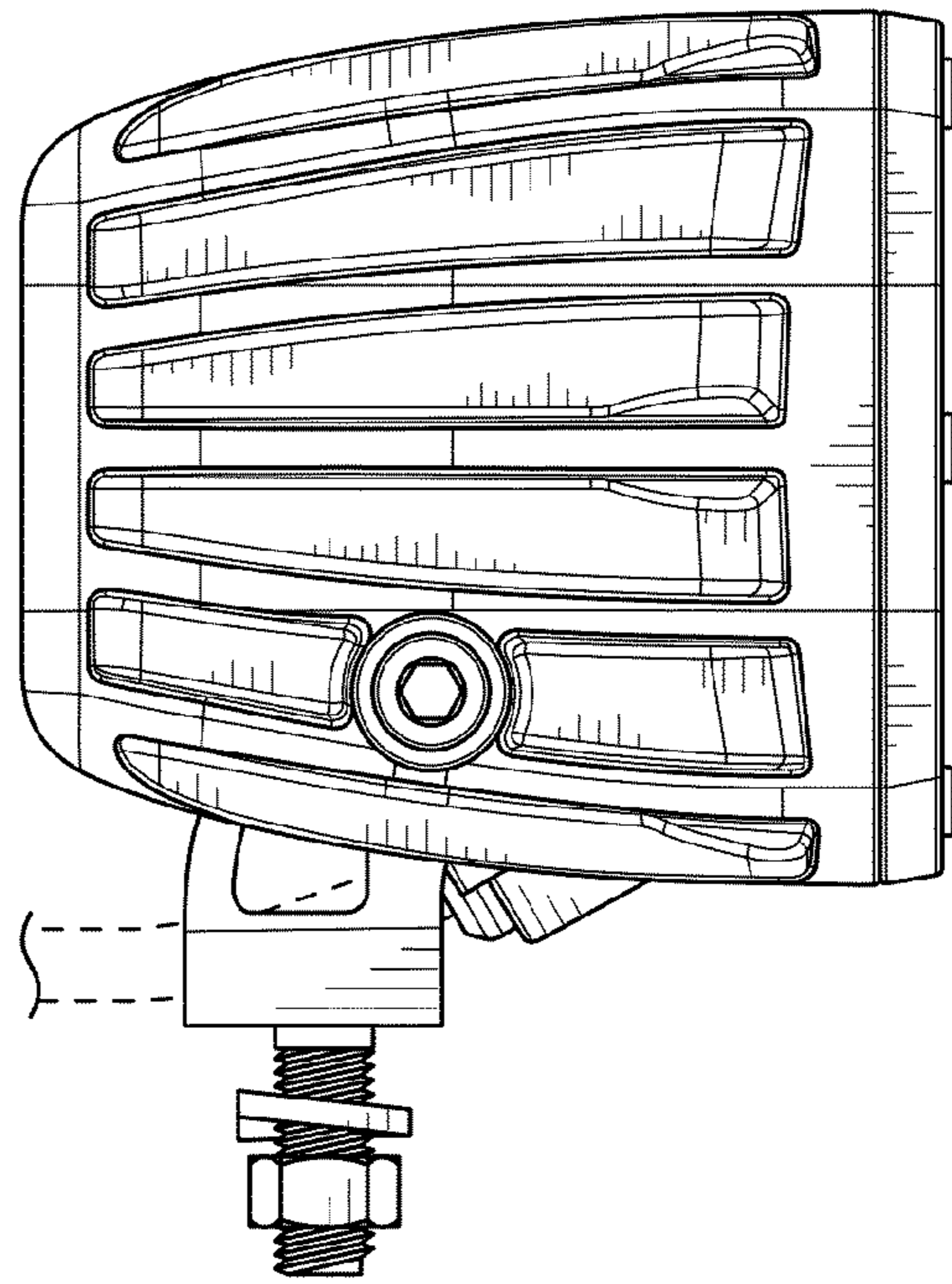

FIG. 5

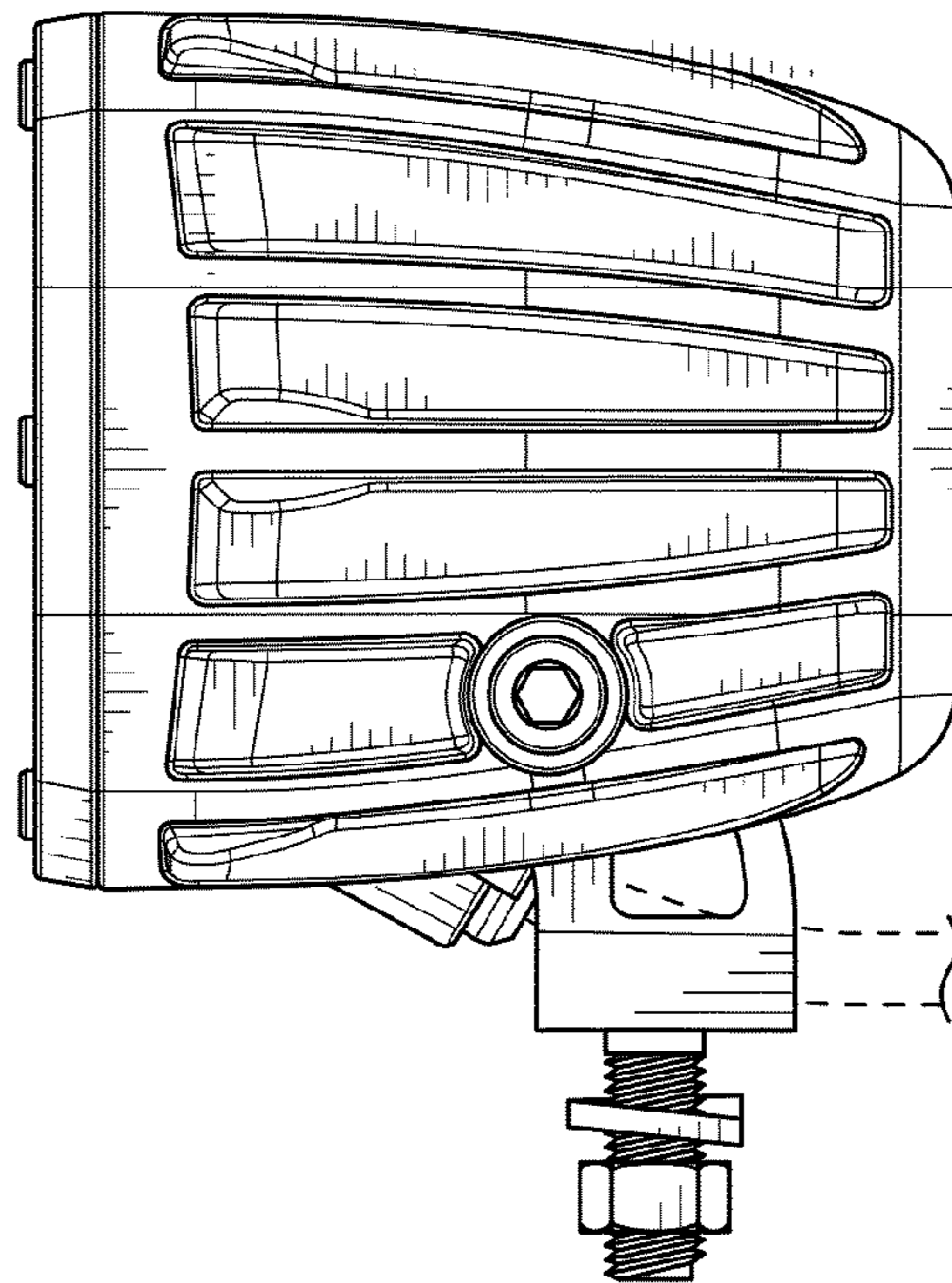

FIG. 6

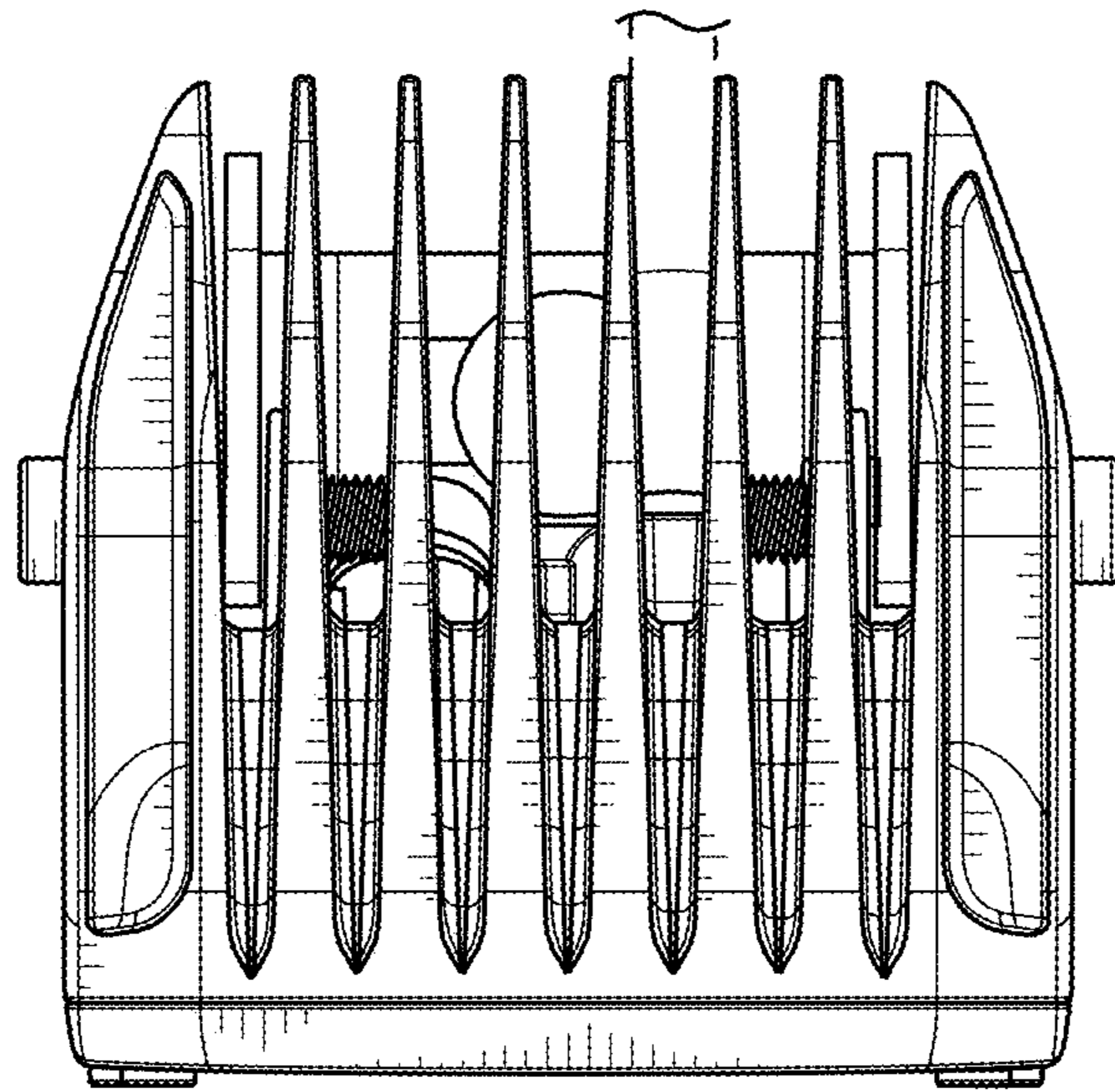

FIG. 7

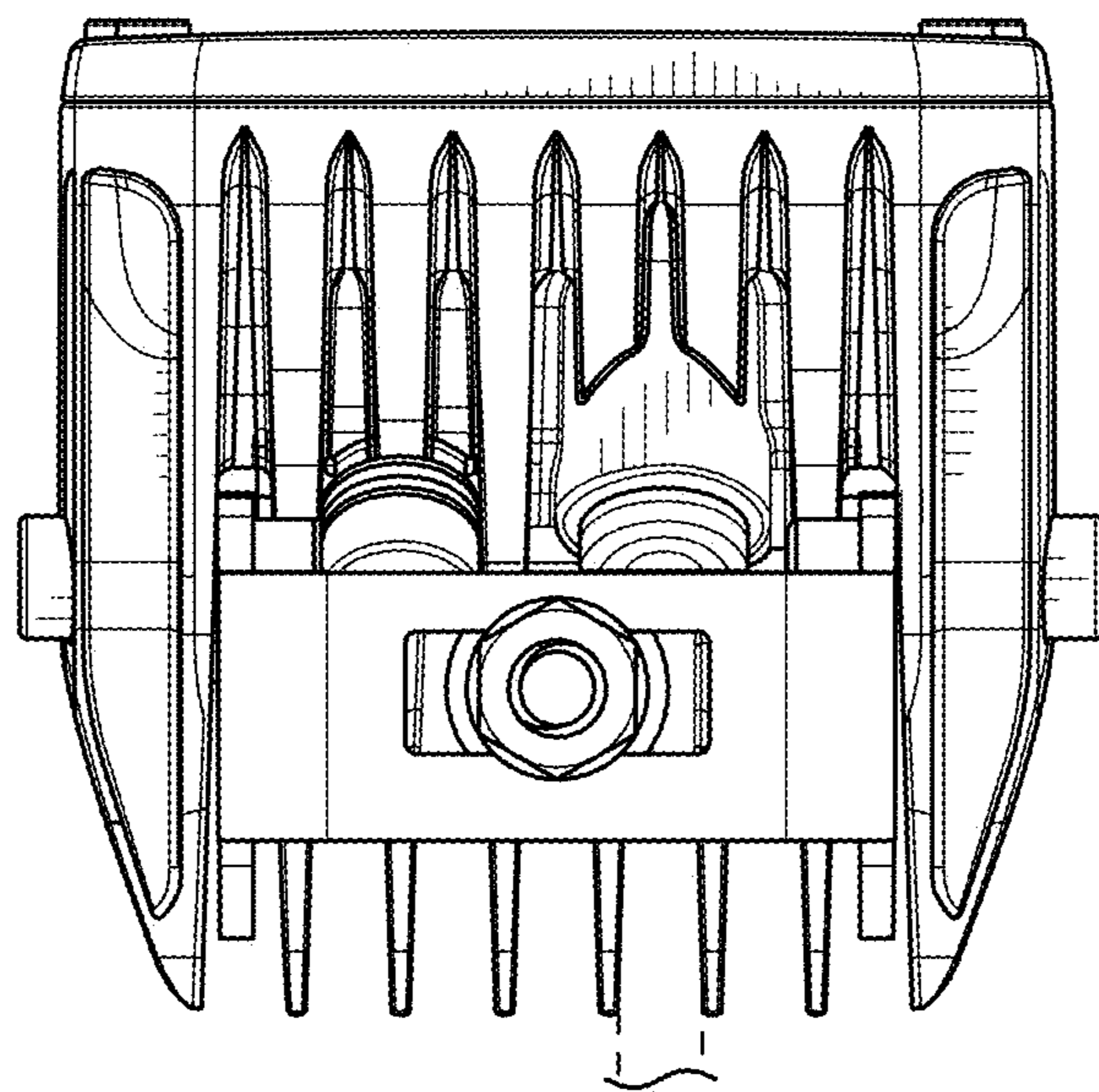

FIG. 8