



US00D704289S

(12) **United States Design Patent**
Jeanneau et al.

(10) **Patent No.:** **US D704,289 S**

(45) **Date of Patent:** **** May 6, 2014**

(54) **HOCKEY STICK SHAFT**

FOREIGN PATENT DOCUMENTS

(71) Applicant: **Sport Maska Inc.**, Montreal (CA)
(72) Inventors: **Phillippe Jeanneau**, Montreal (CA);
Roberto Gazzara, Venice (IT); **Mauro Pezzato**, Treviso (IT)

CA 2562899 A1 11/2007
CA 2563005 A1 11/2007
CA 118800 10/2008
WO 2008129361 A2 10/2008
WO 2009027906 A1 3/2009

(73) Assignee: **Sport Maska Inc.**, Montreal, Quebec (CA)

(**) Term: **14 Years**

(21) Appl. No.: **29/437,999**

(22) Filed: **Nov. 23, 2012**

OTHER PUBLICATIONS

Lacrosse Catalogue 2009; 9K O-Tech Handle Smooth Grip.
U.S. Appl. No. 11/183,585; Complete Hockey Stick System; filed Jul. 18, 2005.

* cited by examiner

Primary Examiner — Mitchell Siegel

(74) *Attorney, Agent, or Firm* — Norton Rose Fulbright Canada LLP

Related U.S. Application Data

(62) Division of application No. 29/377,295, filed on Oct. 20, 2010, now Pat. No. Des. 671,604.

(51) **LOC (10) Cl.** **21-02**

(52) **U.S. Cl.**
USPC **D21/753**

(58) **Field of Classification Search**
USPC D21/727, 753; 473/560–563
See application file for complete search history.

(56) **References Cited**

U.S. PATENT DOCUMENTS

D237,636 S *	11/1975	Leclerc	D21/727
D344,559 S *	2/1994	Ilacqua et al.	D21/727
D360,443 S *	7/1995	Berghash	D21/727
D399,544 S *	10/1998	Liu	D21/727
5,863,268 A *	1/1999	Birch	473/563
D558,844 S *	1/2008	Jeanneau et al.	D21/727
D579,997 S *	11/2008	Jeanneau et al.	D21/753
D606,138 S *	12/2009	Loiars et al.	D21/725
D619,664 S *	7/2010	Loiars et al.	D21/725
D628,666 S *	12/2010	Jeanneau et al.	D21/753
D634,799 S *	3/2011	Loiars et al.	D21/725
D671,604 S *	11/2012	Jeanneau et al.	D21/753
2005/0153798 A1 *	7/2005	Rigoli	473/513
2007/0270253 A1 *	11/2007	Davis et al.	473/513
2007/0275799 A1 *	11/2007	Davis et al.	
2007/0275800 A1 *	11/2007	Davis et al.	473/561

(57) **CLAIM**

The ornamental design for a hockey stick shaft, as shown and described.

DESCRIPTION

FIG. 1 is a rear left isometric view of a fourth embodiment of a hockey stick shaft according to our design;
FIG. 2 is a rear elevation view of the hockey stick shaft of FIG. 1, a front elevation view being a mirror image thereof;
FIG. 3 is a rear left isometric close-up view of the portion of the hockey stick shaft indicated by bracket 3 in FIG. 1, a front right isometric close-up view being identical thereto;
FIG. 4 is a rear elevation view of the portion of the hockey stick shaft of FIG. 3, a front elevation view being identical thereto;
FIG. 5T is a cross-sectional view of the portion of the hockey stick shaft of FIG. 3 taken along the line 5T-5T in FIG. 4;
FIG. 5B is a cross-sectional view of the portion of the hockey stick shaft of FIG. 3 taken along the line 5B-5B in FIG. 4;
FIG. 6T is a cross-sectional view of the portion of the hockey stick shaft of FIG. 3 taken along the line 6T-6T in FIG. 4;
FIG. 6B is a cross-sectional view of the portion of the hockey stick shaft of FIG. 3 taken along the line 6B-6B in FIG. 4;
FIG. 7 is a rear left isometric view of a seventh embodiment of a hockey stick shaft according to our design;

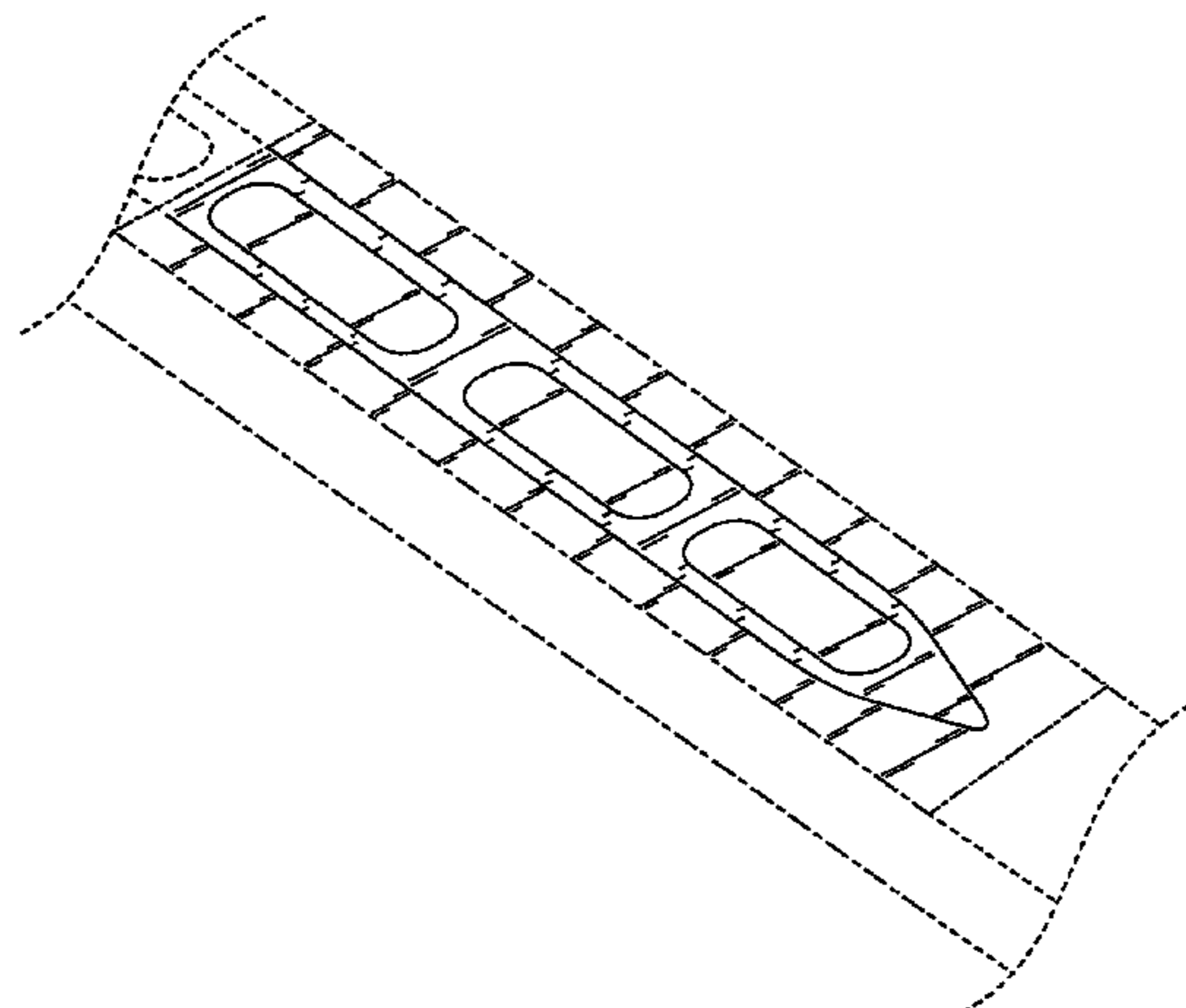

FIG. 8 is a rear elevation view of the hockey stick shaft of FIG. 7, a front elevation view being a mirror image thereof;

FIG. 9 is a rear left isometric close-up view of the portion of the hockey stick shaft indicated by bracket 9 in FIG. 7, a front right isometric close-up view being identical thereto;

FIG. 10 is a rear elevation view of the portion of the hockey stick shaft of FIG. 9, a front elevation view being identical thereto;

FIG. 11 is a cross-sectional view of the portion of the hockey stick shaft of FIG. 9 taken along the line 11-11 in FIG. 10, a cross-sectional view in the opposite direction being a mirror image thereof;

FIG. 12T is a cross-sectional view of the portion of the hockey stick shaft of FIG. 9 taken along the line 12T-12T in FIG. 10;

FIG. 12B is a cross-sectional view of the portion of the hockey stick shaft of FIG. 9 taken along the line 12B-12B in FIG. 10;

FIG. 13T is a cross-sectional view of the portion of the hockey stick shaft of FIG. 9 taken along the line 13T-13T in FIG. 10;

FIG. 13B is a cross-sectional view of the portion of the hockey stick shaft of FIG. 9 taken along the line 13B-13B in FIG. 10;

FIG. 14 is an elevation view of a slice of the portion of the hockey stick shaft of FIG. 9 taken along the plane extending along the line 14-14 in FIG. 10 perpendicular to the image thereof;

FIG. 15 is a rear left isometric view of a nineteenth embodiment of a hockey stick shaft according to our design;

FIG. 16 is a rear elevation view of the hockey stick shaft of FIG. 15, a front elevation view being a mirror image thereof;

FIG. 17 is a rear left isometric close-up view of the portion of the hockey stick shaft indicated by bracket 17 in FIG. 15, a front right isometric close-up view being identical thereto;

FIG. 18 is a rear left isometric close-up view of the portion of the hockey stick shaft indicated by bracket 18 in FIG. 15, a front right isometric close-up view being identical thereto;

FIG. 19 is a rear elevation view of the portion of the hockey stick shaft of FIG. 17, a front elevation view being identical thereto;

FIG. 20 is a rear elevation view of the portion of the hockey stick shaft of FIG. 18, a front elevation view being identical thereto;

FIG. 21 is a cross-sectional view of the portion of the hockey stick shaft of FIG. 17 taken along the line 21-21 in FIG. 19, a cross-sectional view in the opposite direction being a mirror image thereof;

FIG. 22 is a cross-sectional view of the portion of the hockey stick shaft of FIG. 18 taken along the line 22-22 in FIG. 20, a cross-sectional view in the opposite direction being a mirror image thereof;

FIG. 23T is a cross-sectional view of the hockey stick shaft of FIG. 15 taken both along the line 23T-23T in FIG. 19 and along the line 23T-23T in FIG. 20;

FIG. 23B is a cross-sectional view of the hockey stick shaft of FIG. 15 taken both along the line 23B-23B in FIG. 19 and along the line 23B-23B in FIG. 20;

FIG. 24T is a cross-sectional view of the hockey stick shaft of FIG. 15 taken both along the line 24T-24T in FIG. 19 and along the line 24T-24T in FIG. 20;

FIG. 24B is a cross-sectional view of the hockey stick shaft of FIG. 15 taken both along the line 24B-24B in FIG. 19 and along the line 24B-24B in FIG. 20;

FIG. 25 is an elevation view of a slice of the portion of the hockey stick shaft of FIG. 15 taken along the plane extending along the line 25-25 in FIG. 19 perpendicular to the image thereof, and is also an elevation view of a slice of the portion of the hockey stick shaft of FIG. 20 taken along the plane extending along the line 25-25 in FIG. 20 perpendicular to the image thereof;

FIG. 26 is a rear left isometric view of a twentieth embodiment of a hockey stick shaft according to our design;

FIG. 27 is a rear elevation view of the hockey stick shaft of FIG. 26, a front elevation view being a mirror image thereof;

FIG. 28 is a rear left isometric close-up view of the portion of the hockey stick shaft indicated by bracket 28 in FIG. 26, a front right isometric close-up view being identical thereto;

FIG. 29 is a rear left isometric close-up view of the portion of the hockey stick shaft indicated by bracket 29 in FIG. 26, a front right isometric close-up view being identical thereto;

FIG. 30 is a rear elevation view of the portion of the hockey stick shaft of FIG. 28, a front elevation view being identical thereto;

FIG. 31 is a rear elevation view of the portion of the hockey stick shaft of FIG. 29, a front elevation view being identical thereto;

FIG. 32 is a cross-sectional view of the portion of the hockey stick shaft of FIG. 28 taken along the line 32-32 in FIG. 30, a cross-sectional view in the opposite direction being a mirror image thereof;

FIG. 33 is a cross-sectional view of the portion of the hockey stick shaft of FIG. 29 taken along the line 33-33 in FIG. 31, a cross-sectional view in the opposite direction being a mirror image thereof;

FIG. 34T is a cross-sectional view of the hockey stick shaft of FIG. 26 taken both along the line 34T-34T in FIG. 30 and along the line 34T-34T in FIG. 31;

FIG. 34B is a cross-sectional view of the hockey stick shaft of FIG. 26 taken both along the line 34B-34B in FIG. 30 and along the line 34B-34B in FIG. 31;

FIG. 35T is a cross-sectional view of the hockey stick shaft of FIG. 26 taken both along the line 35T-35T in FIG. 30 and along the line 35T-35T in FIG. 31;

FIG. 35B is a cross-sectional view of the hockey stick shaft of FIG. 26 taken both along the line 35B-35B in FIG. 30 and along the line 35B-35B in FIG. 31; and,

FIG. 36 is an elevation view of a slice of the portion of the hockey stick shaft of FIG. 26 taken along the plane extending along the line 36-36 in FIG. 30 perpendicular to the image thereof, and is also an elevation view of a slice of the portion of the hockey stick shaft of FIG. 26 taken along the plane extending along the line 36-36 in FIG. 31 perpendicular to the image thereof.

Throughout the Figures, where shown: (i) the dotted lines showing additional structure of the hockey stick shaft are for illustrative purposes only and form no part of the claimed design; (ii) the dotted lines showing a typical hockey stick blade are for illustrative purposes only and do not form part of the claimed design; (iii) the unshaded surfaces do not form part of the claimed design; (iv) the dotted/dashed lines illustrate unclaimed boundaries of surfaces claimed as part of the design; and (v) brackets and cross-section indications are for reference purposes only and do not form part of the claimed design.

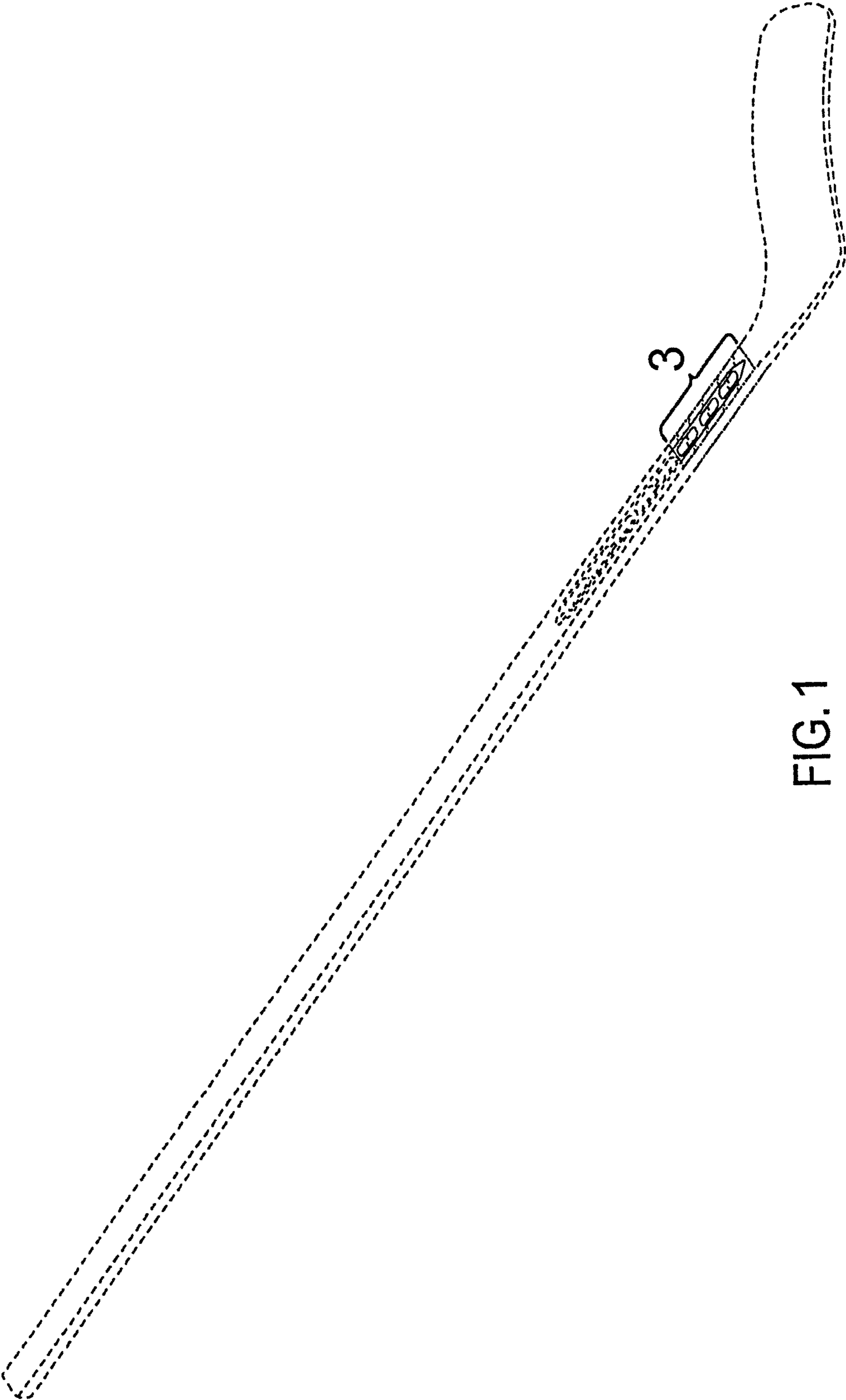

FIG. 1

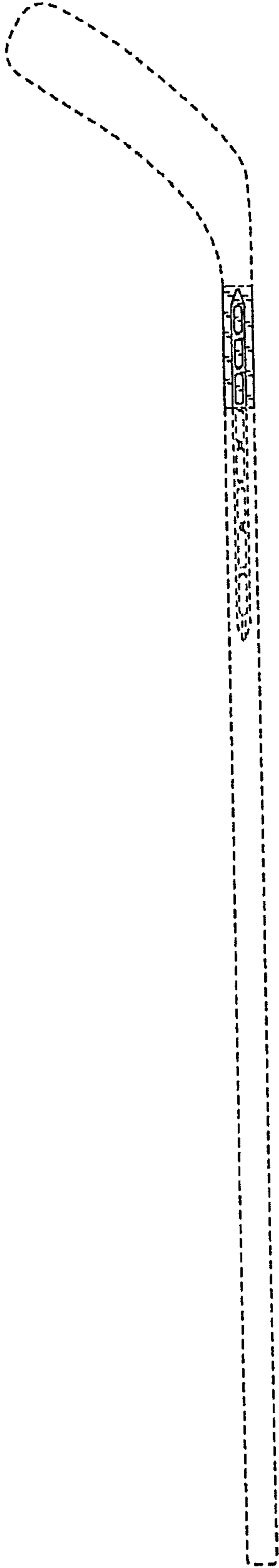

FIG. 2

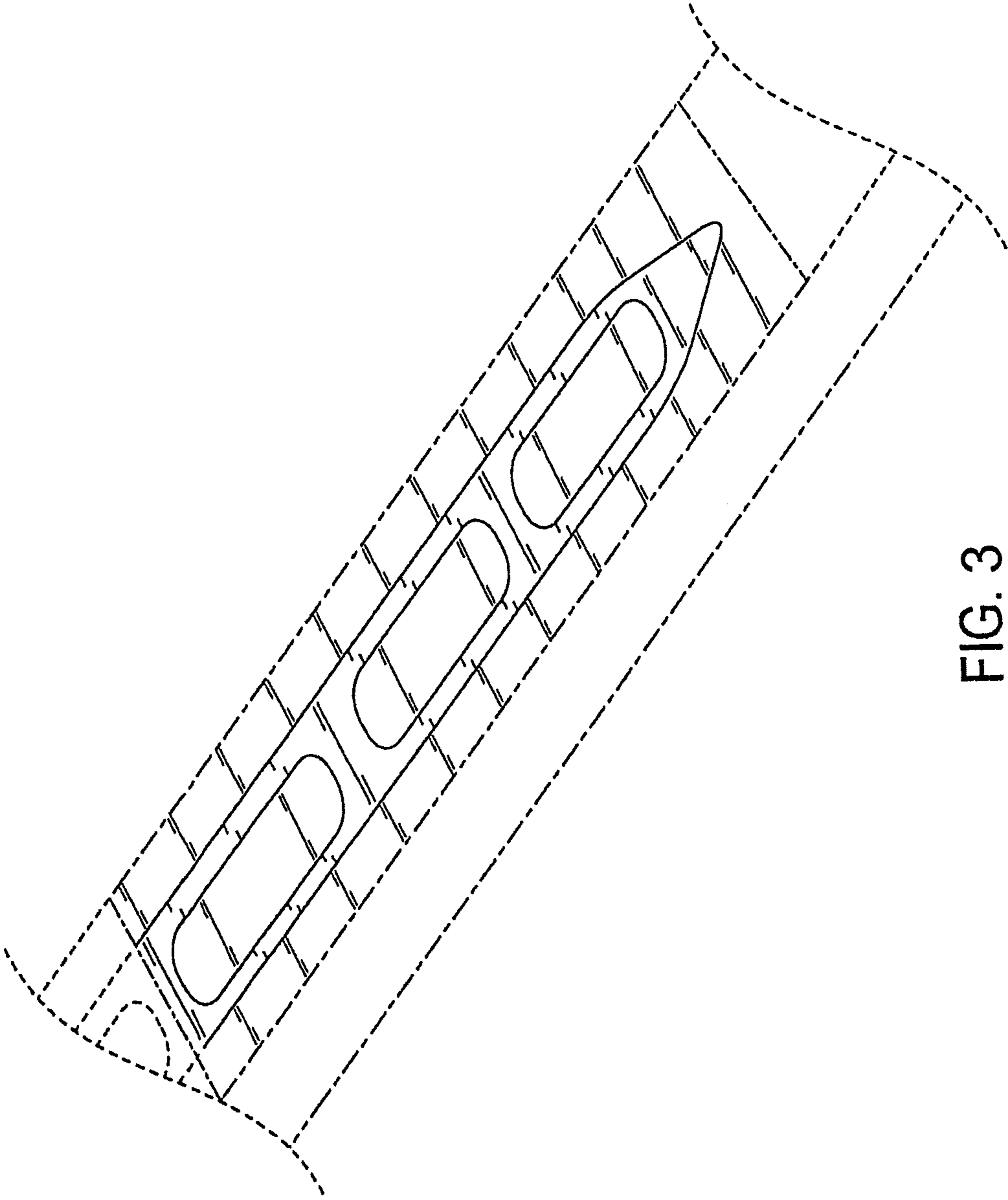

FIG. 3

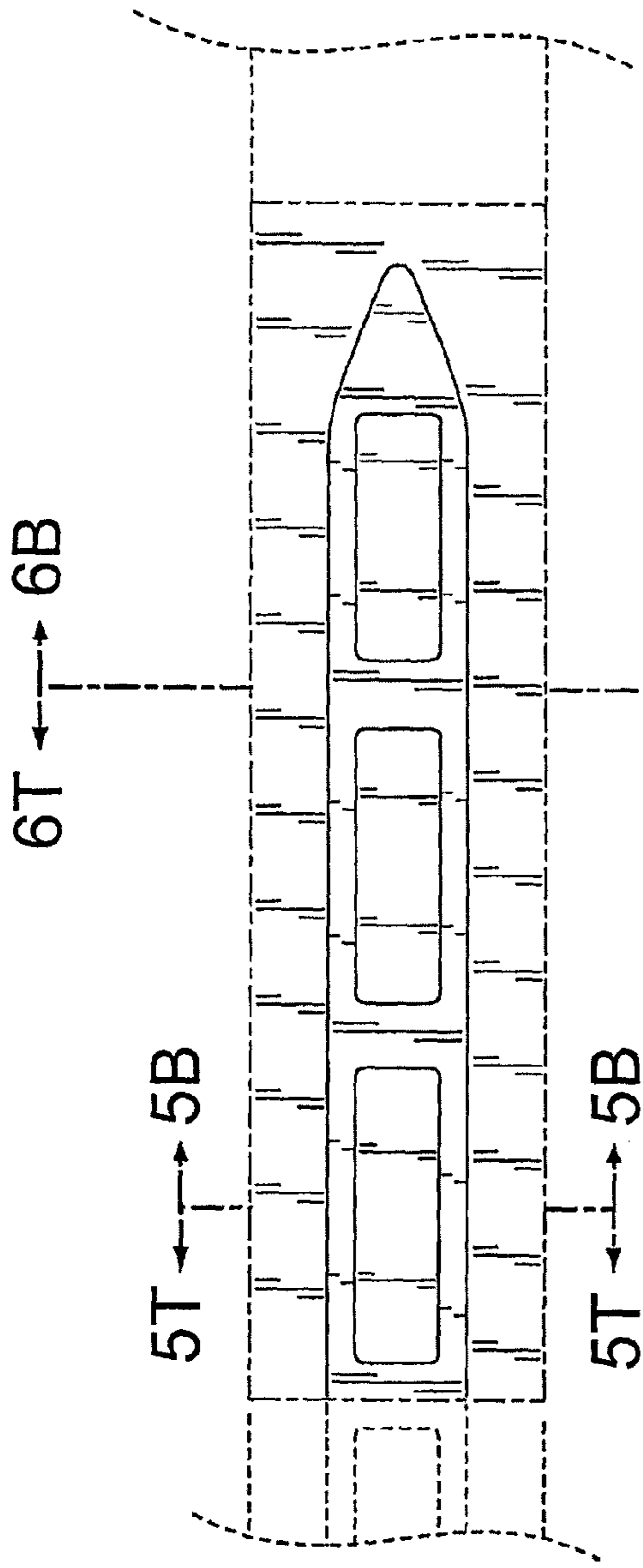

FIG. 4

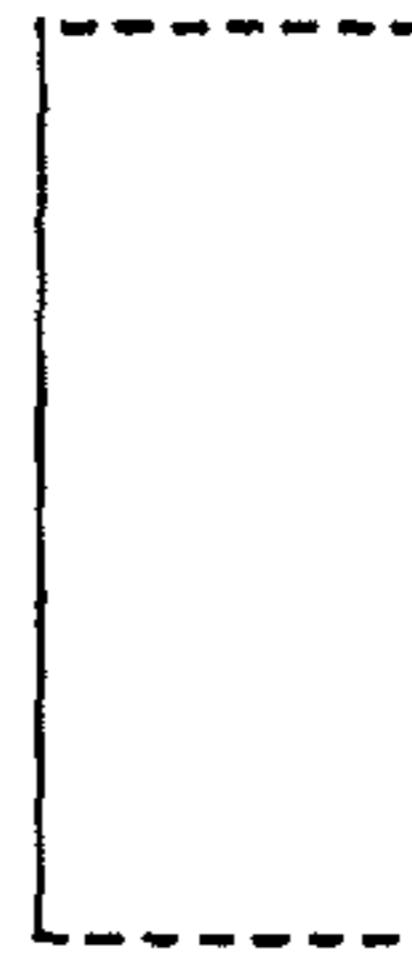

FIG. 5B



FIG. 5T



FIG. 6B



FIG. 6T

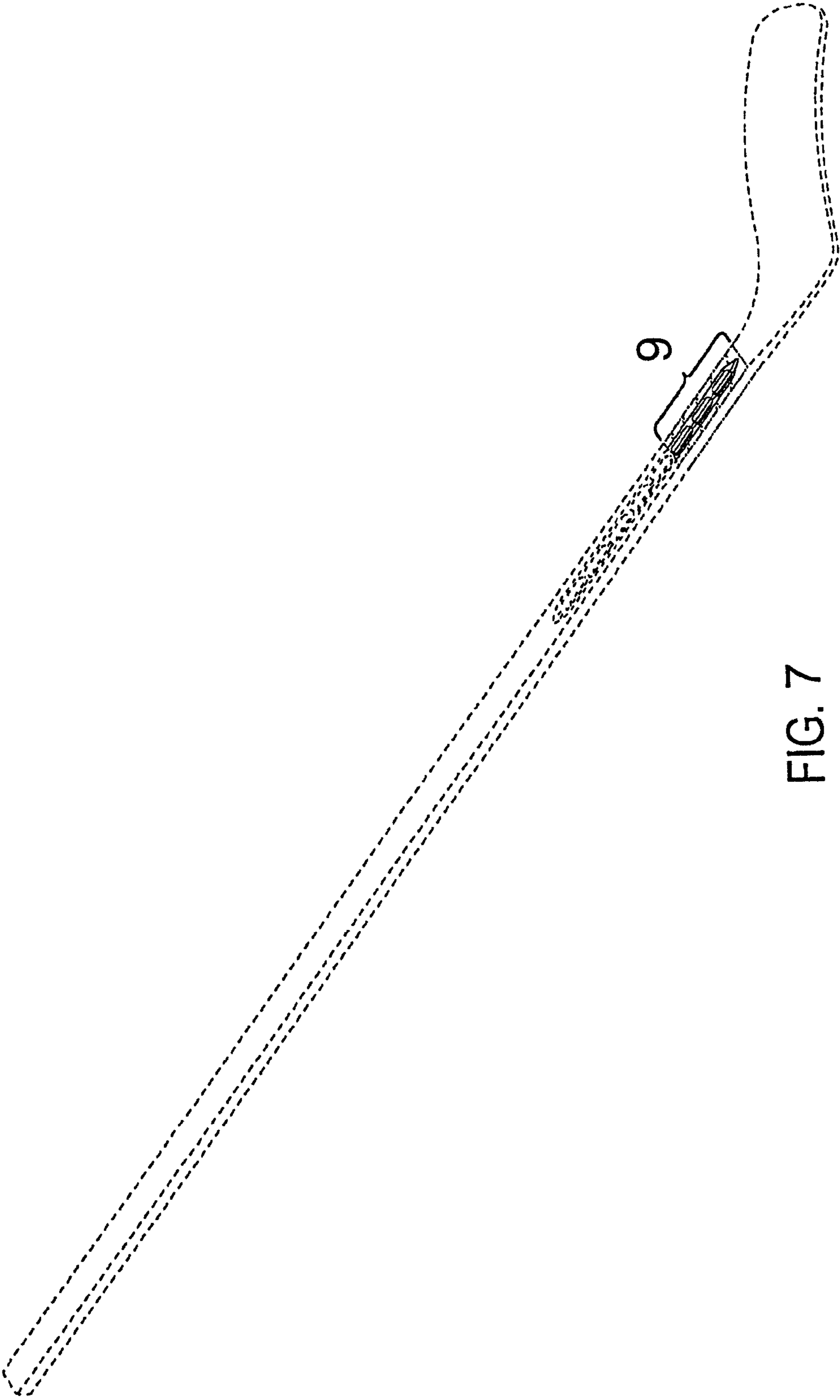

FIG. 7

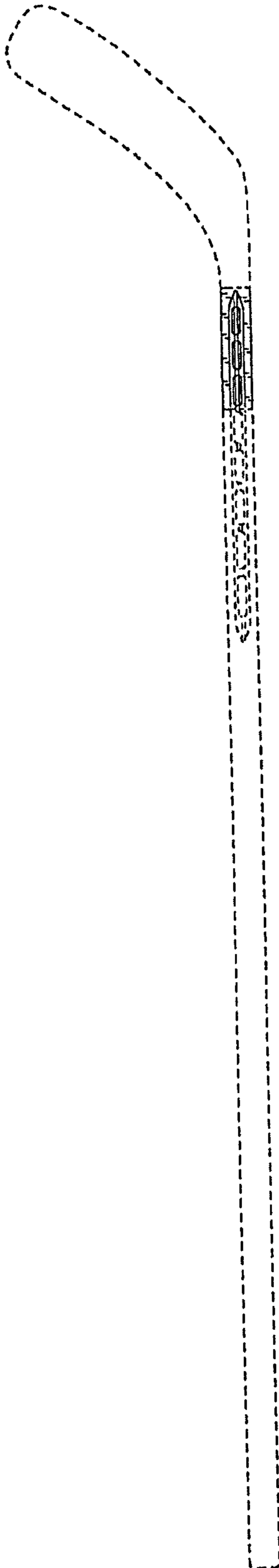

FIG. 8

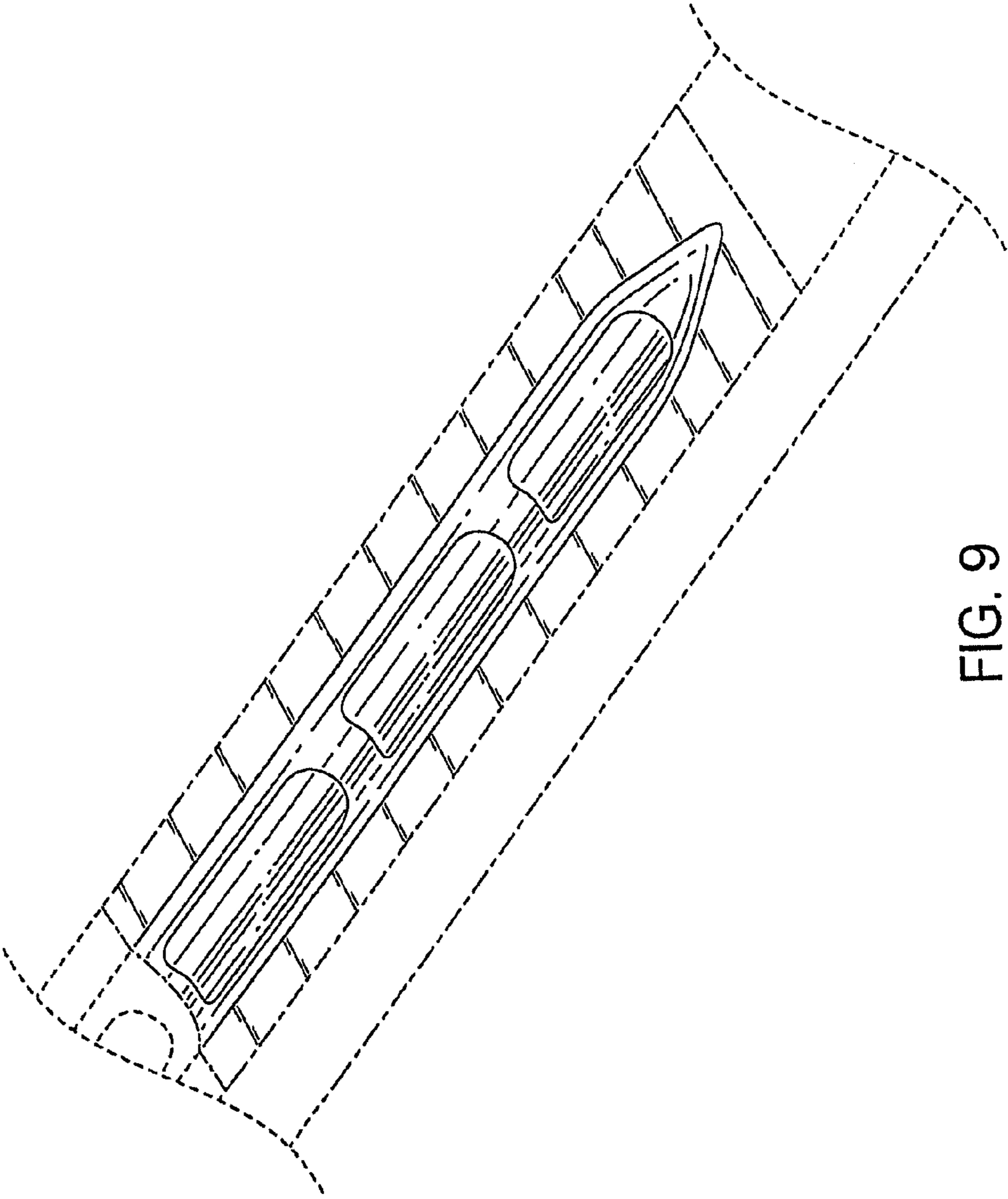

FIG. 9

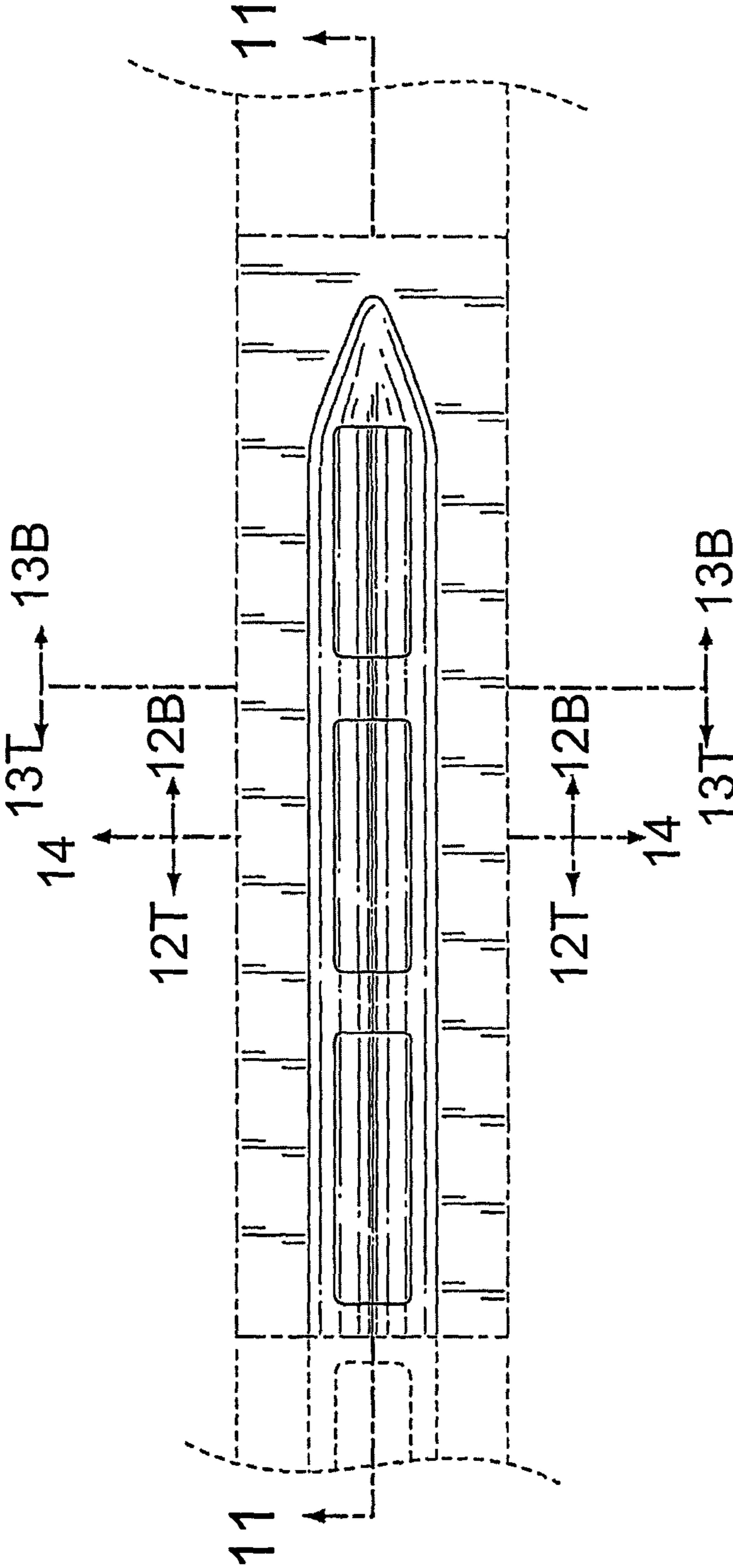

FIG. 10

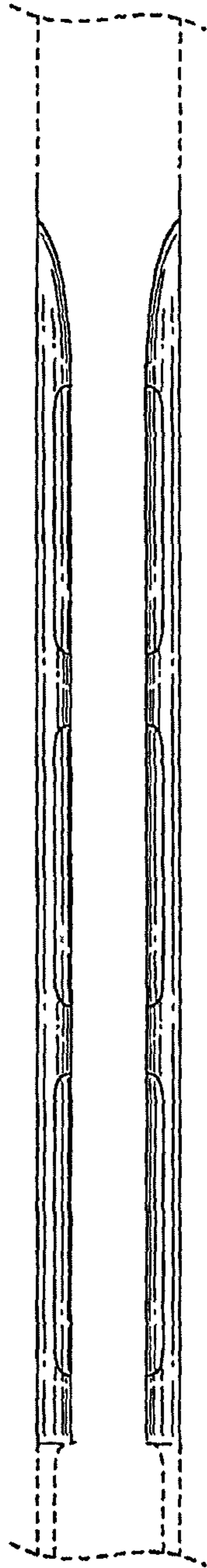

FIG. 11

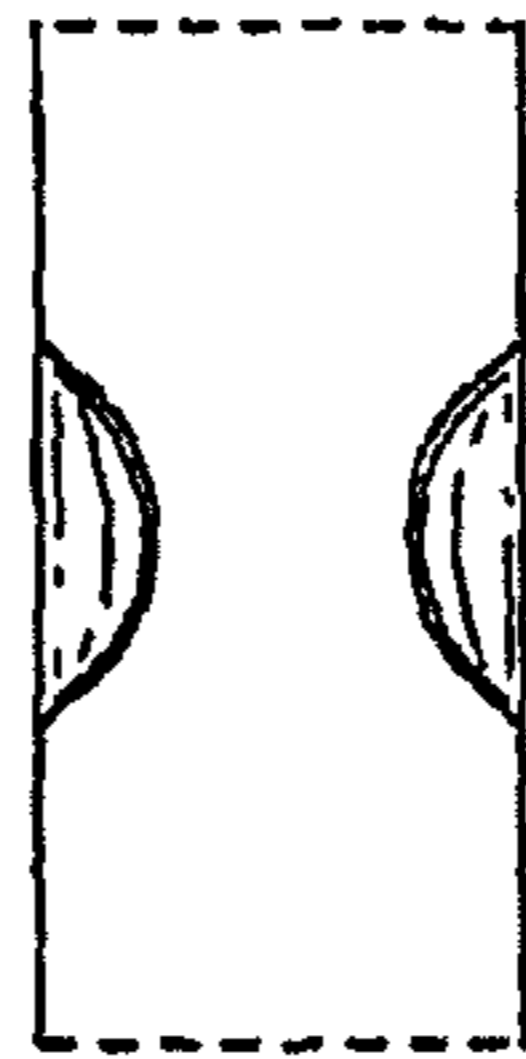

FIG. 12B

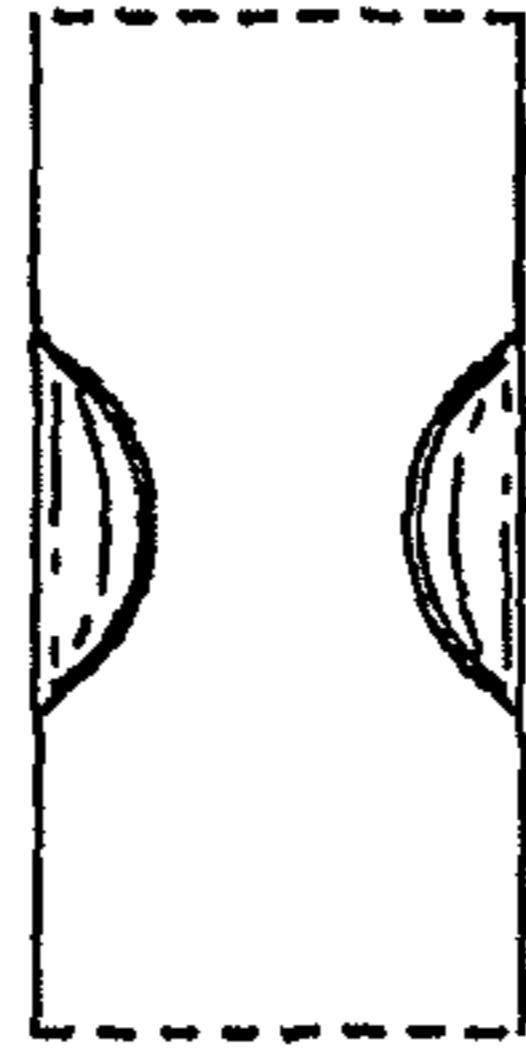

FIG. 13B

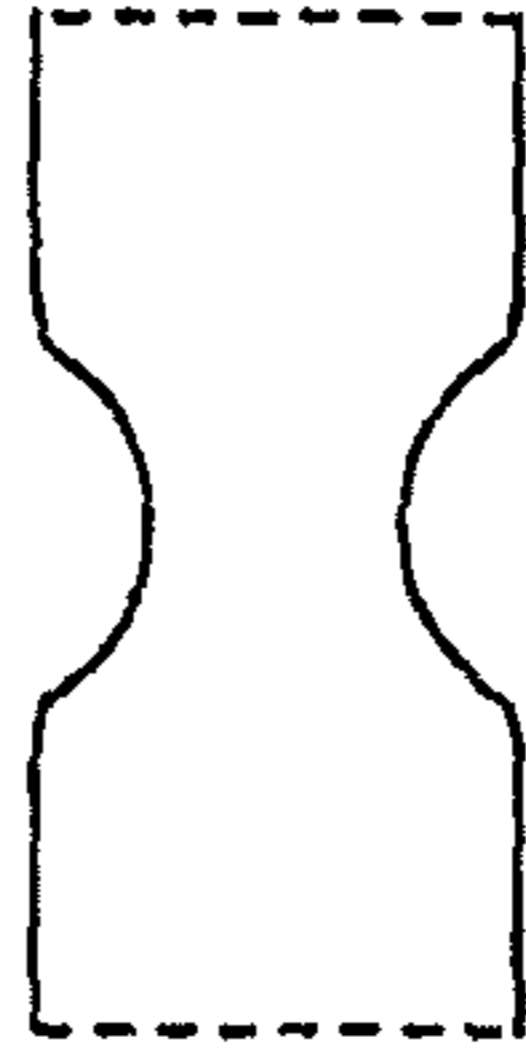

FIG. 14

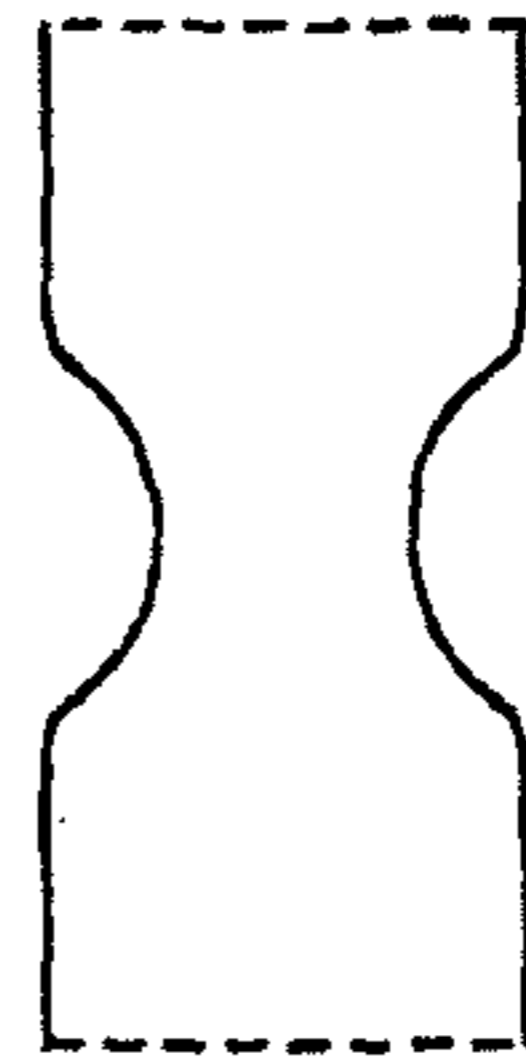

FIG. 12T

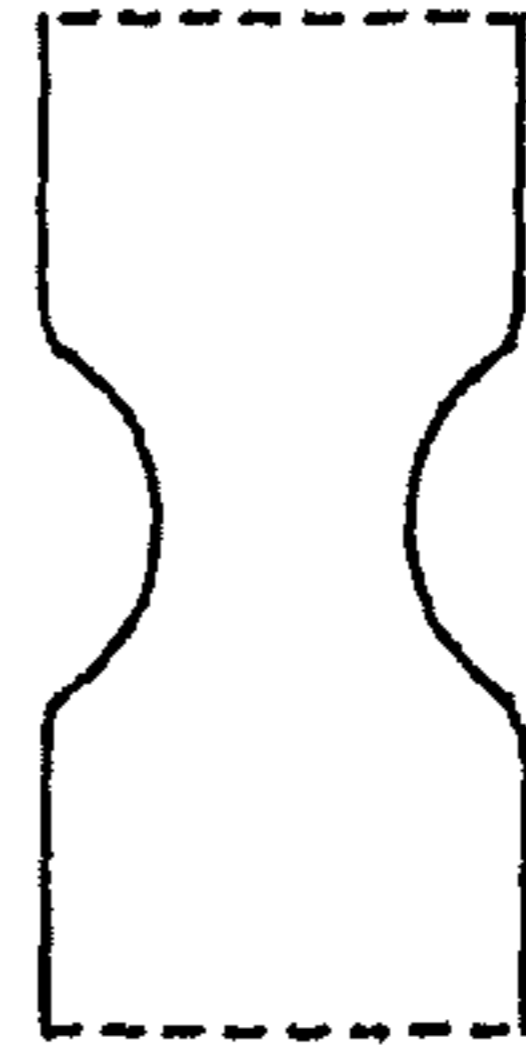

FIG. 13T

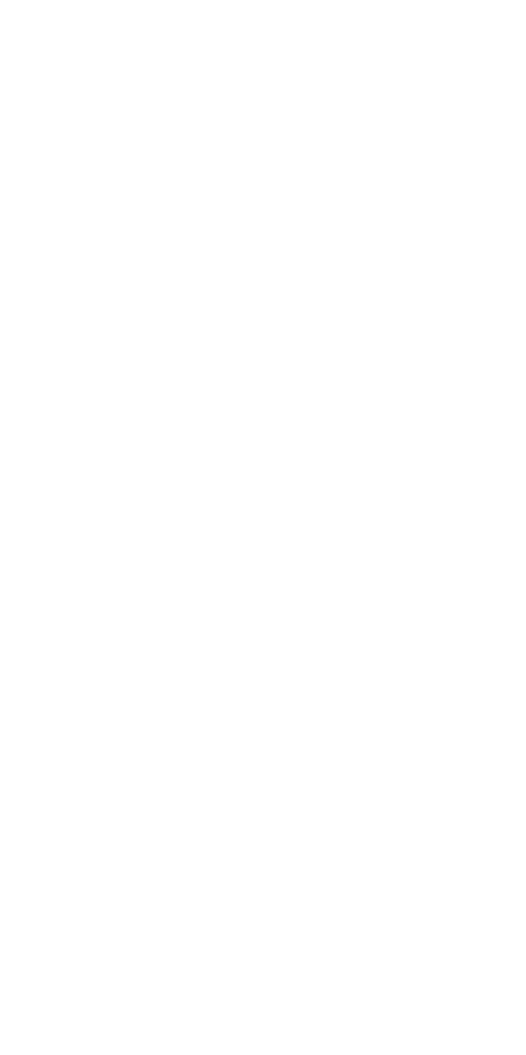

FIG. 14

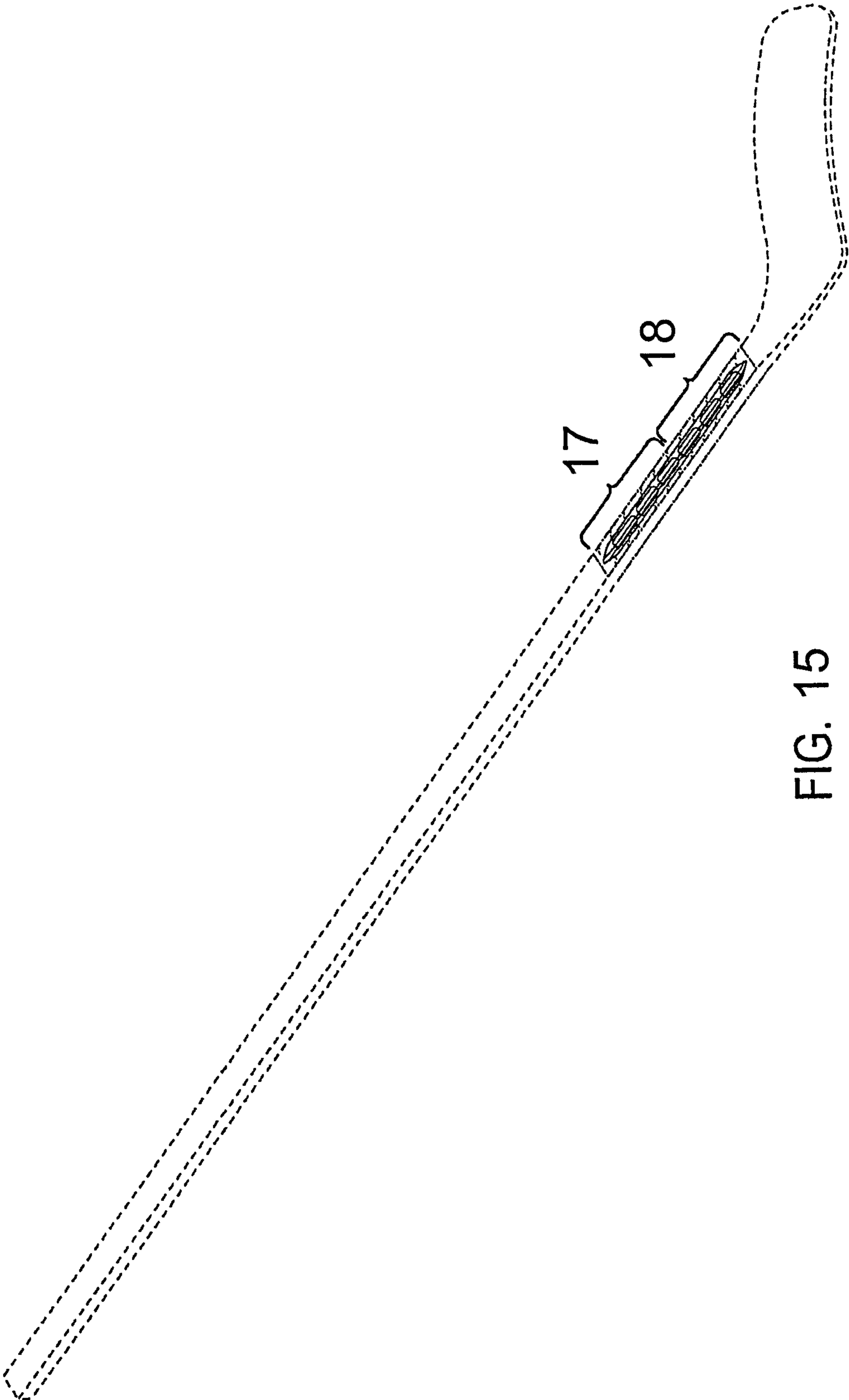

FIG. 15

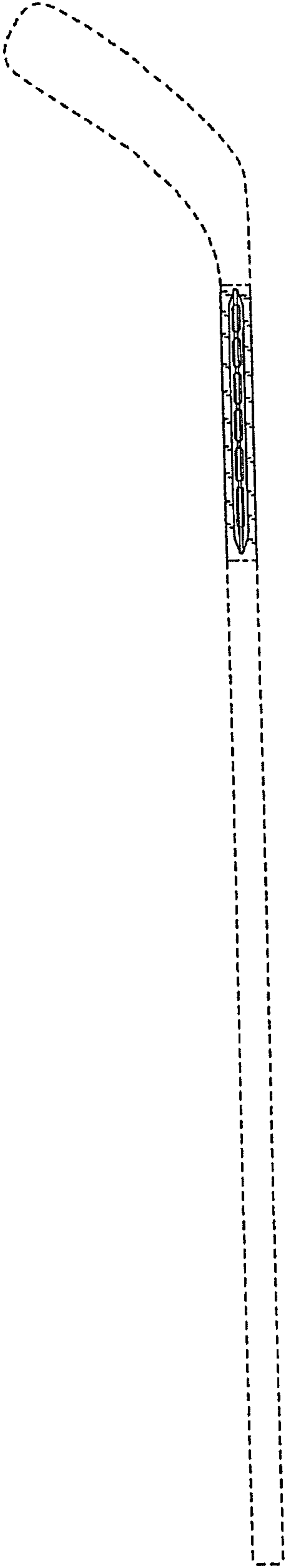

FIG. 16

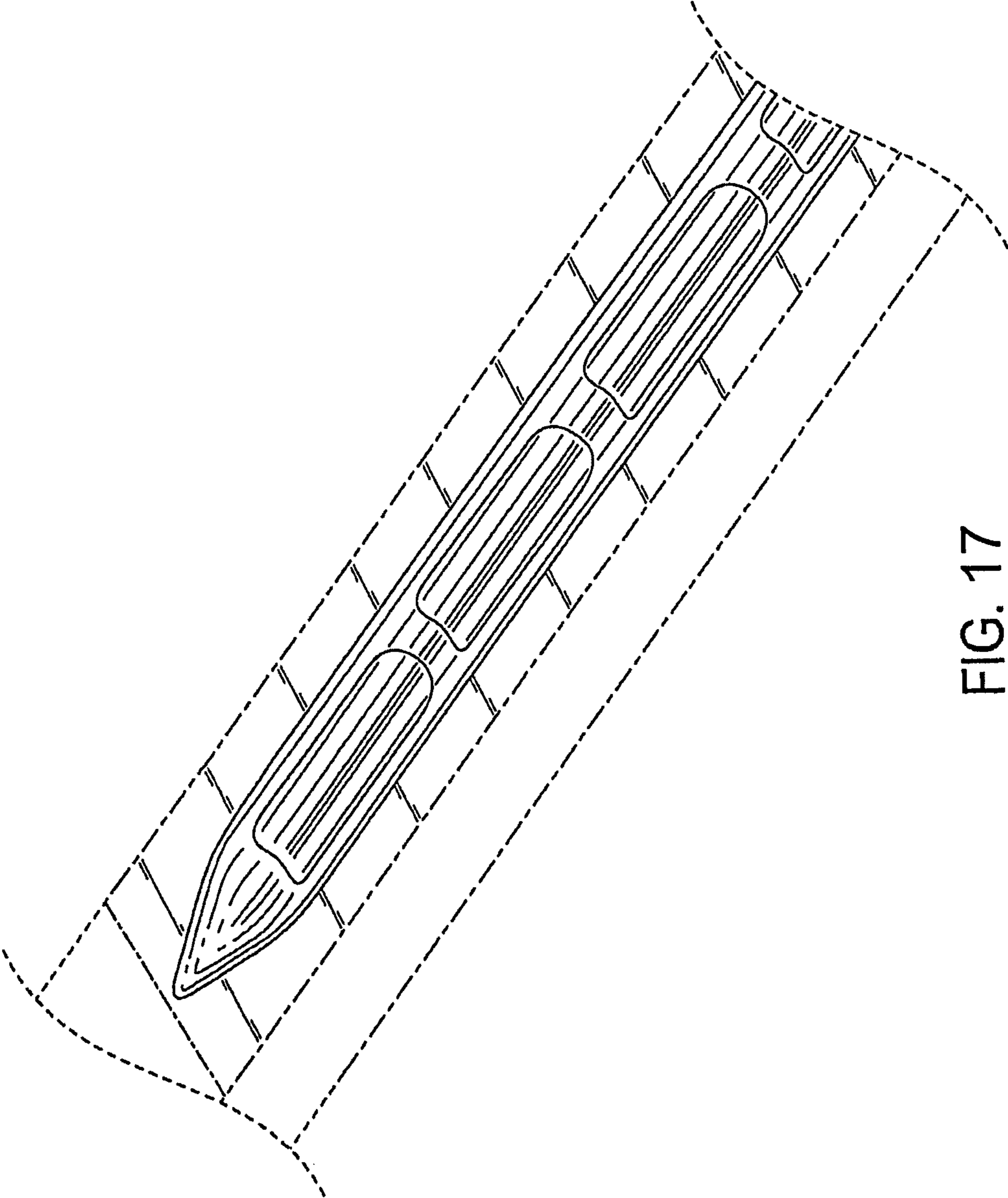

FIG. 17

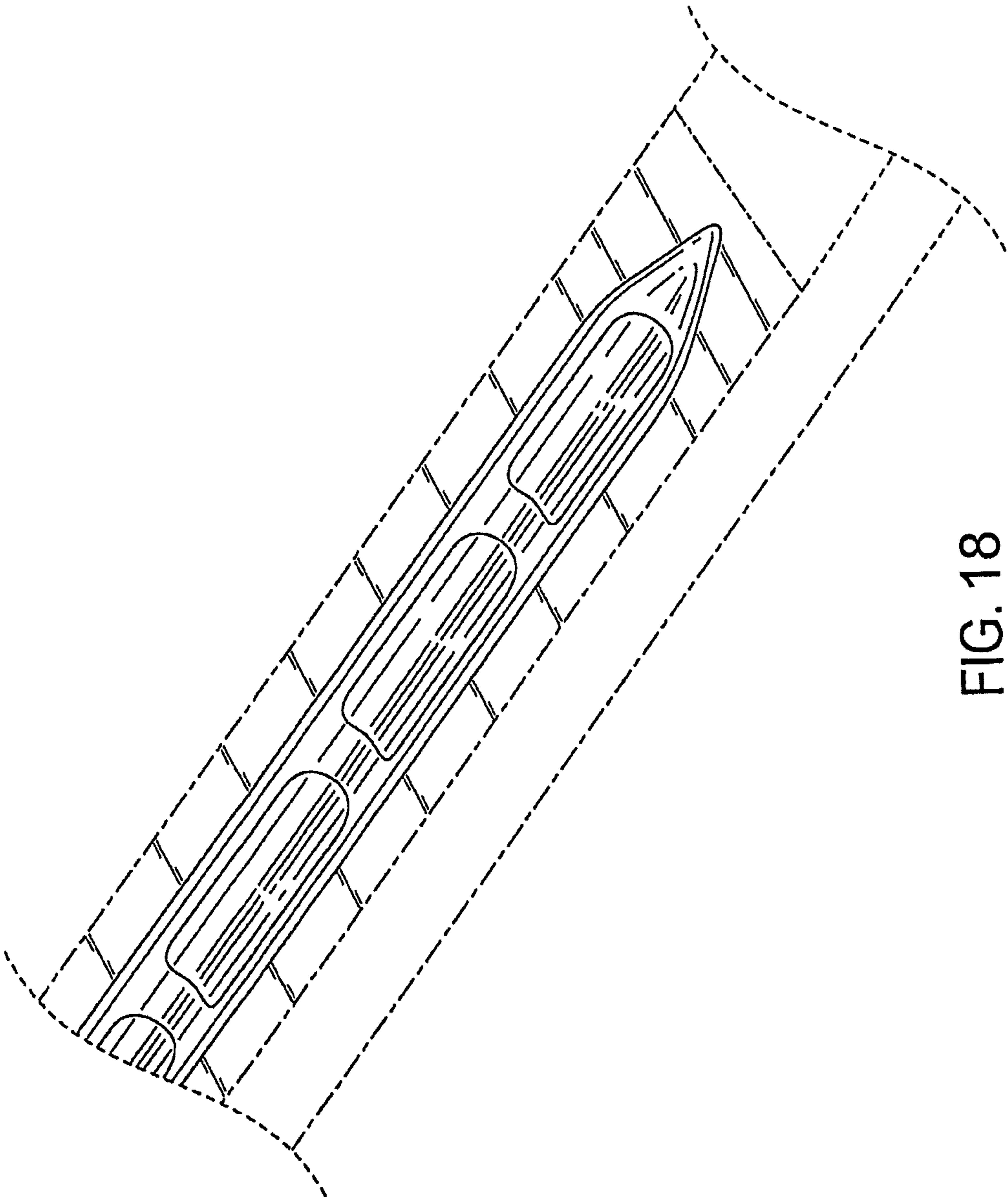

FIG. 18

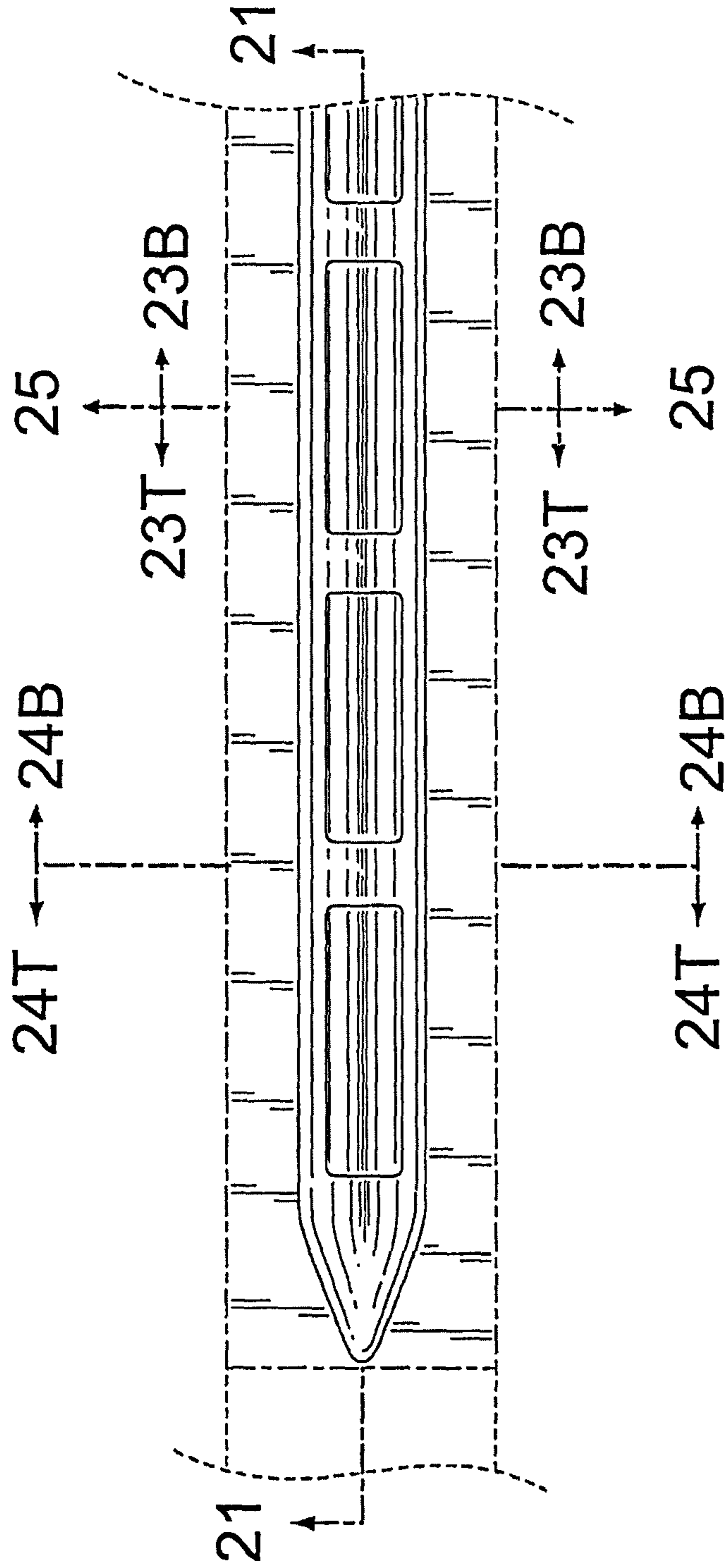

FIG. 19

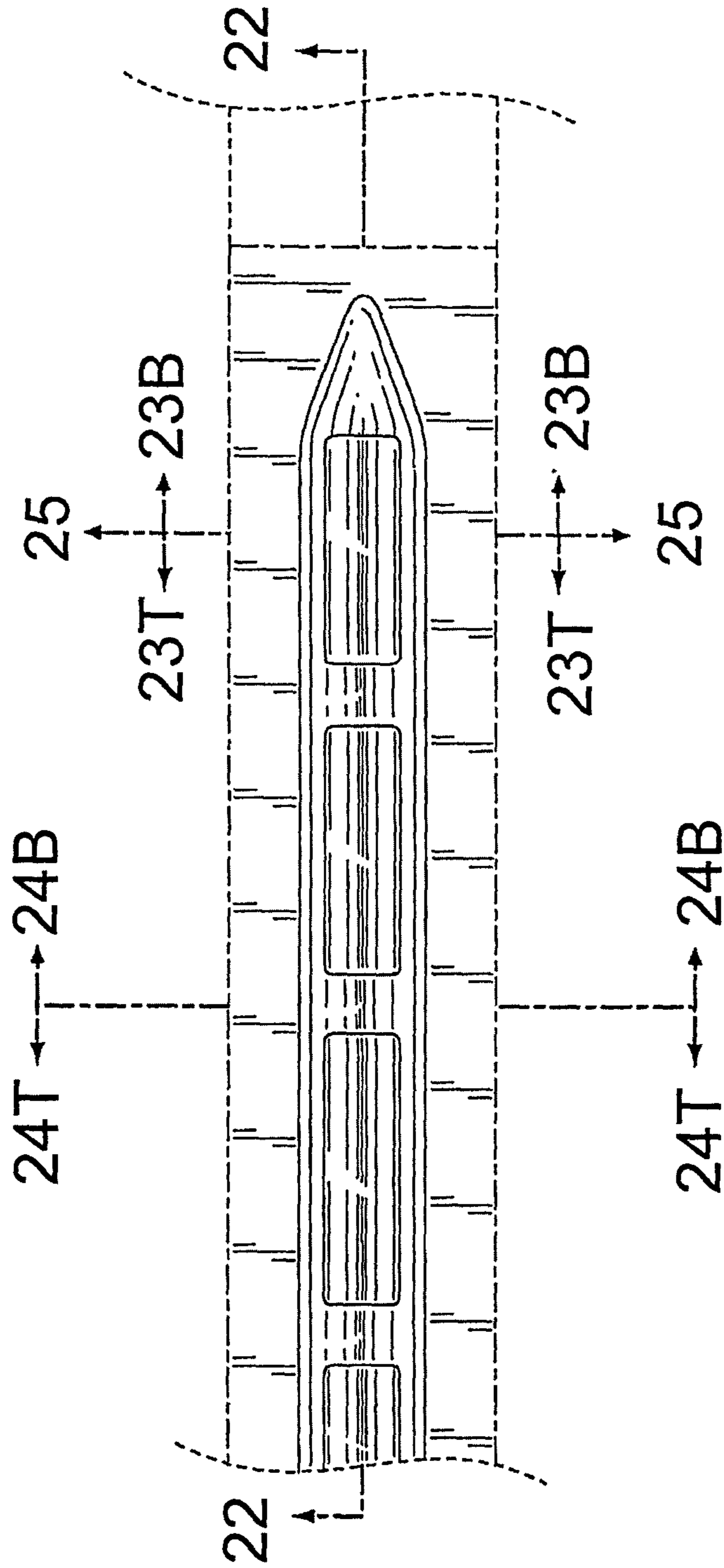

FIG. 20

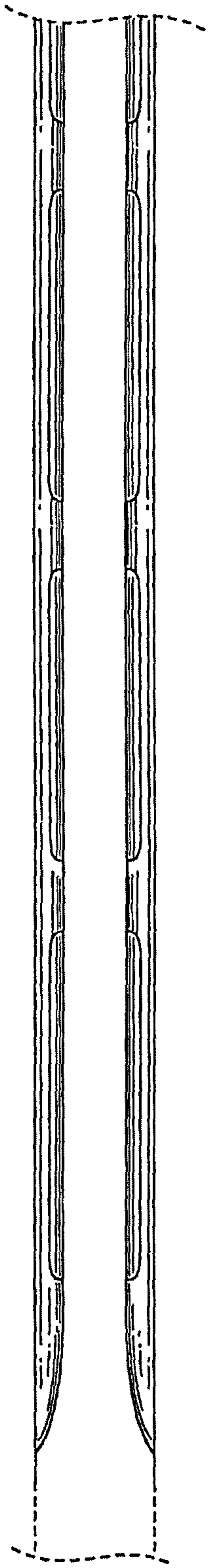

FIG. 21

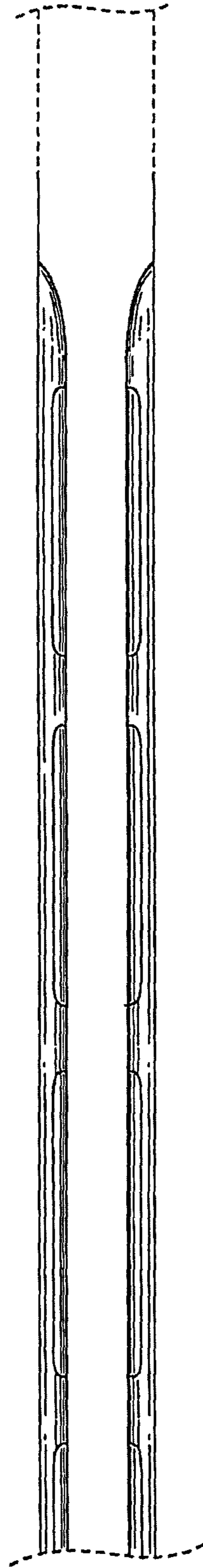

FIG. 22

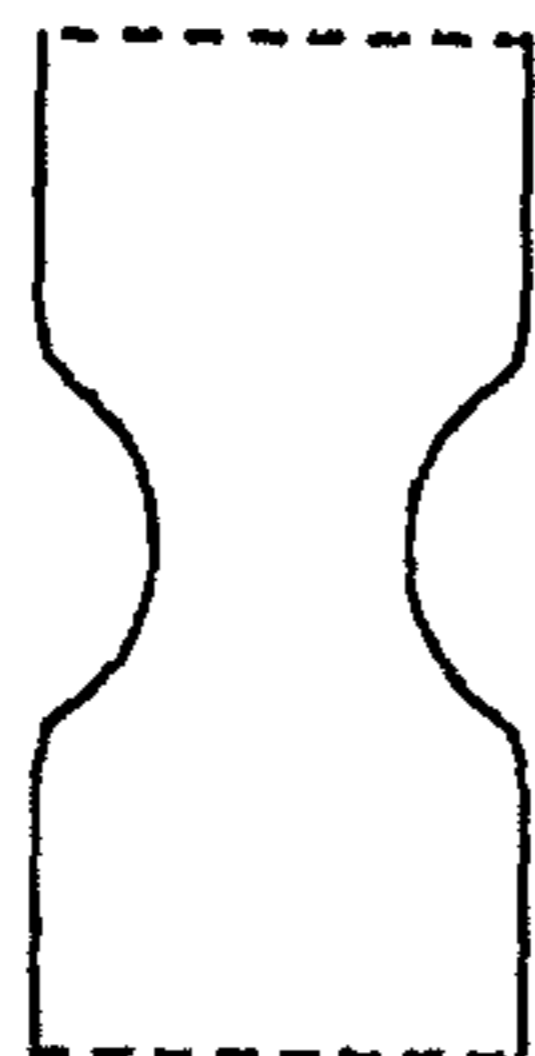

FIG. 25

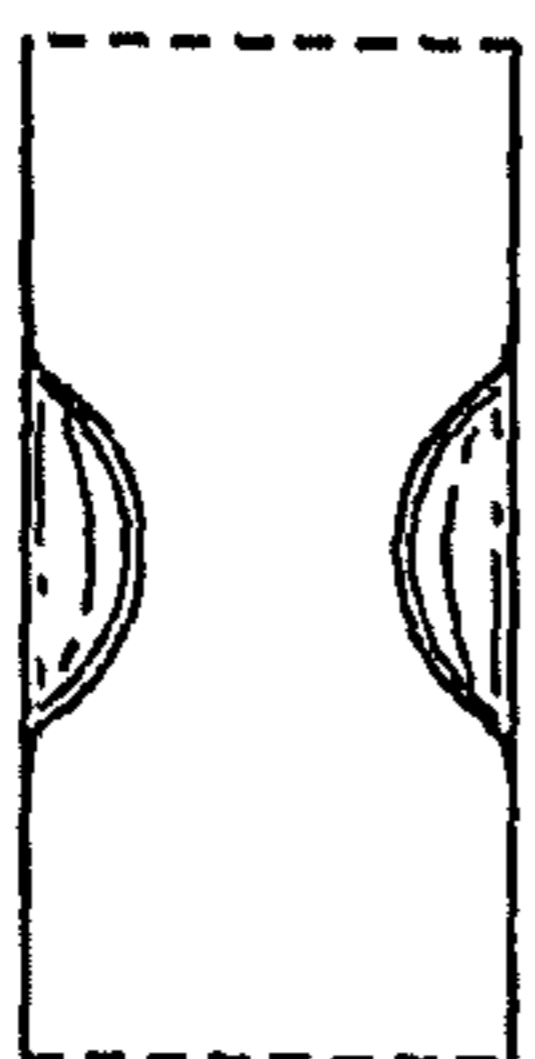

FIG. 24B

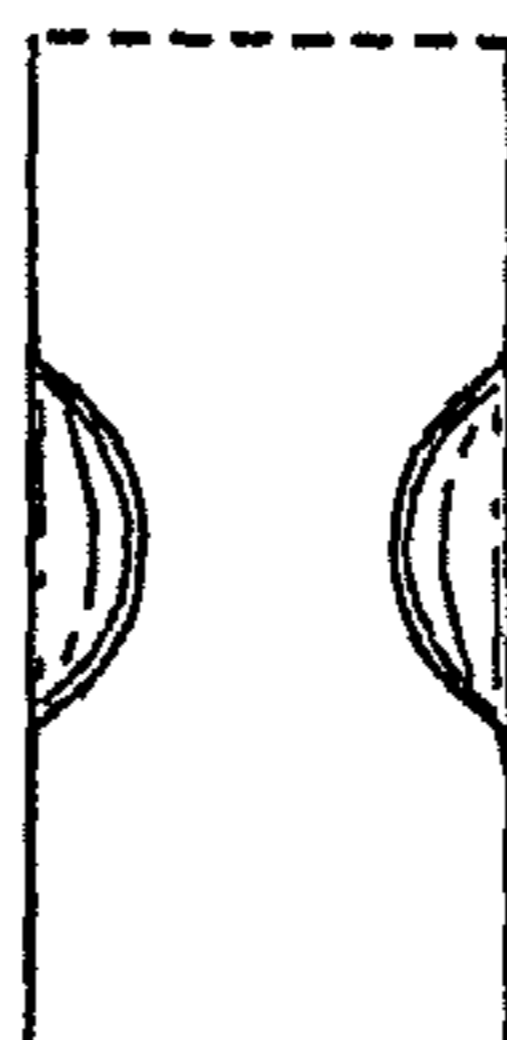

FIG. 24T

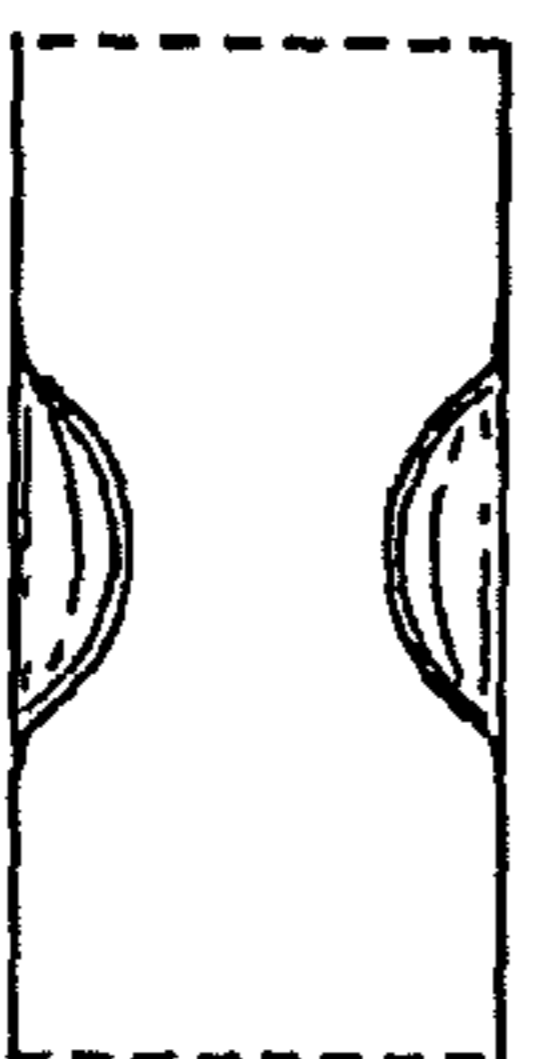

FIG. 23B

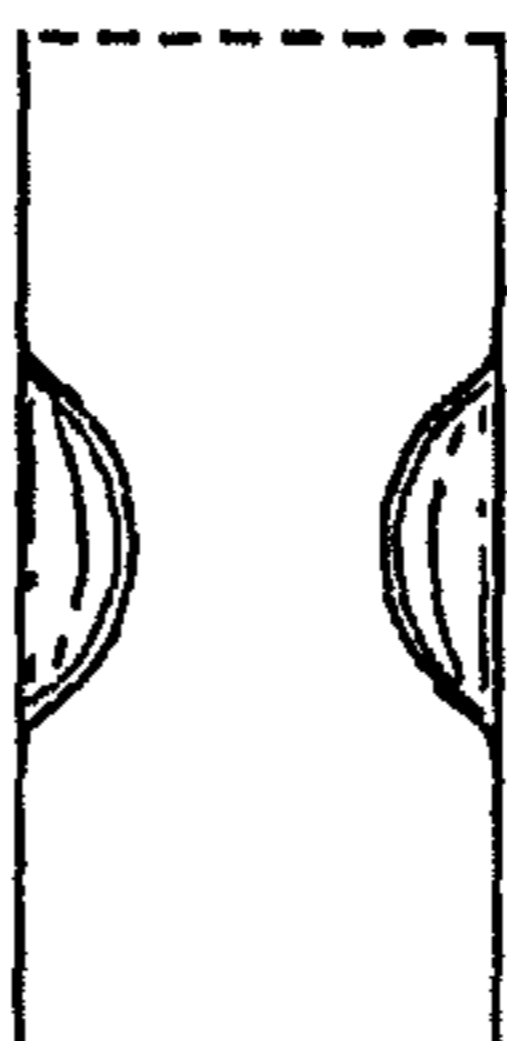

FIG. 23T

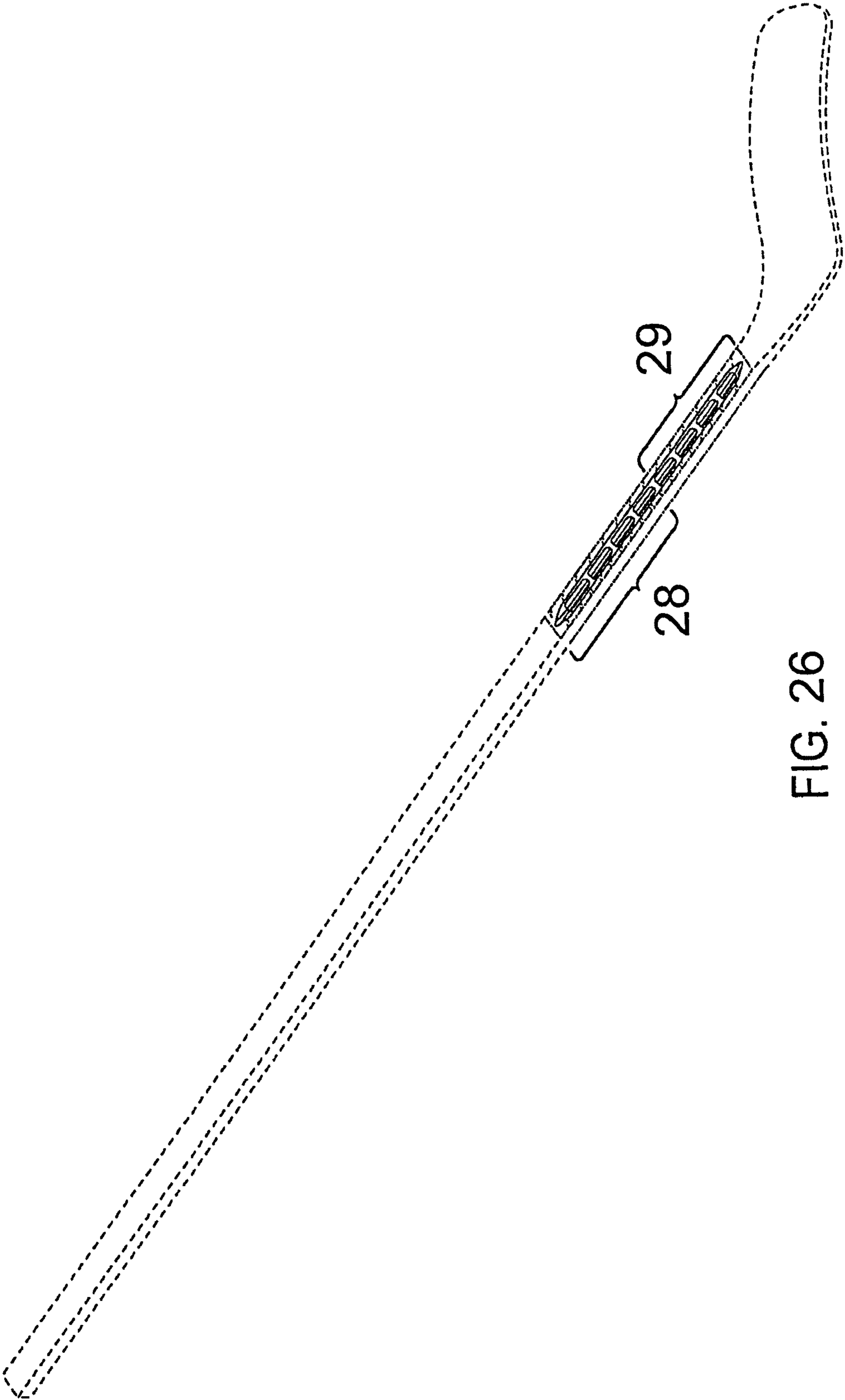

FIG. 26

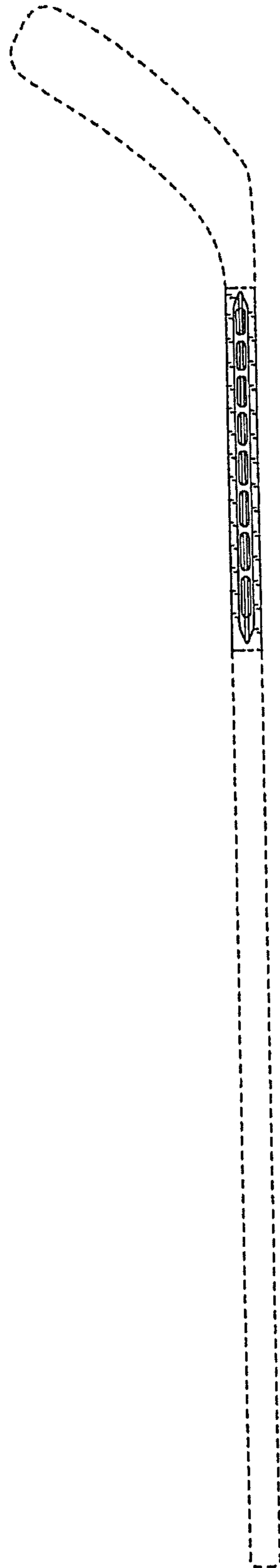

FIG. 27

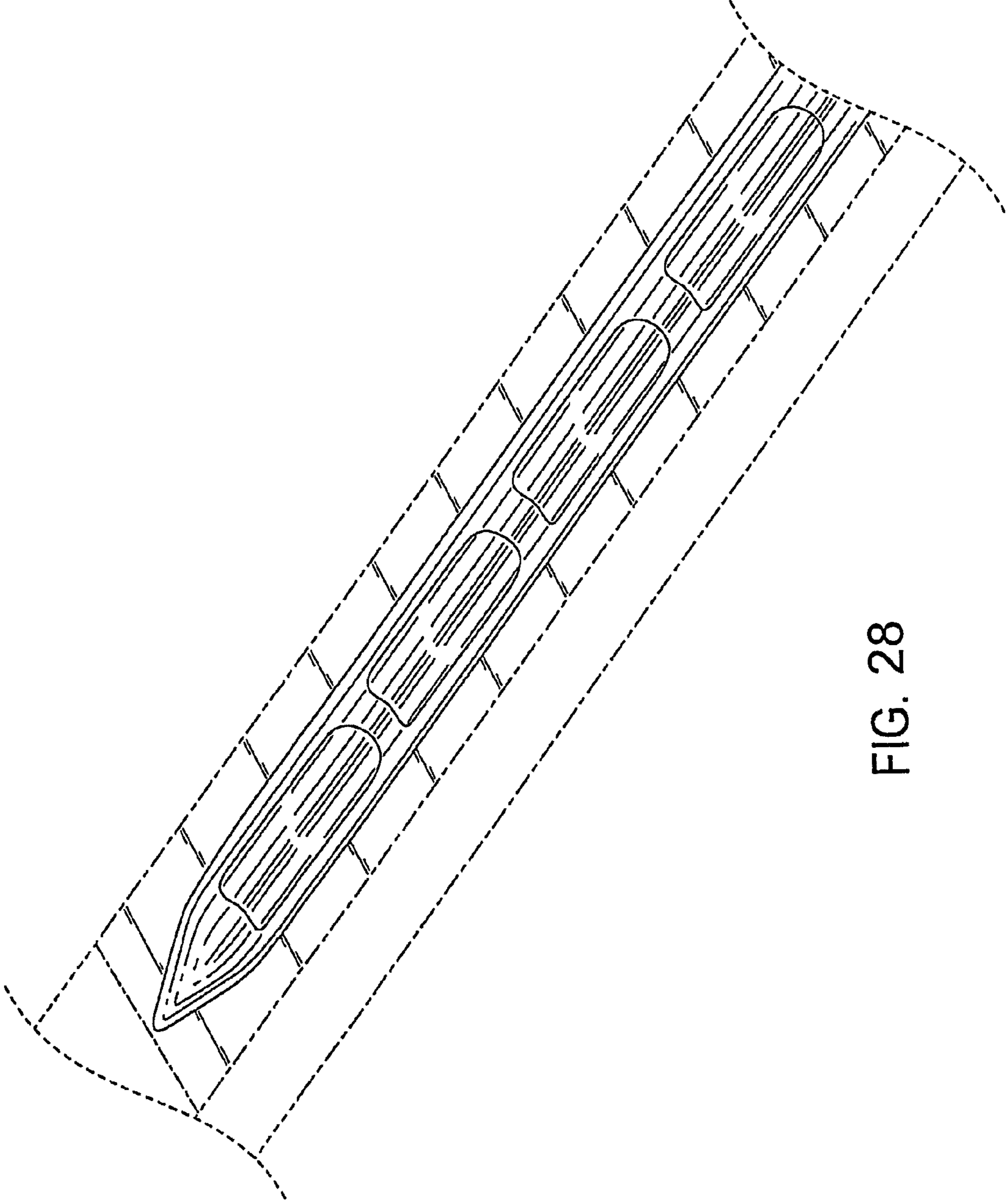

FIG. 28

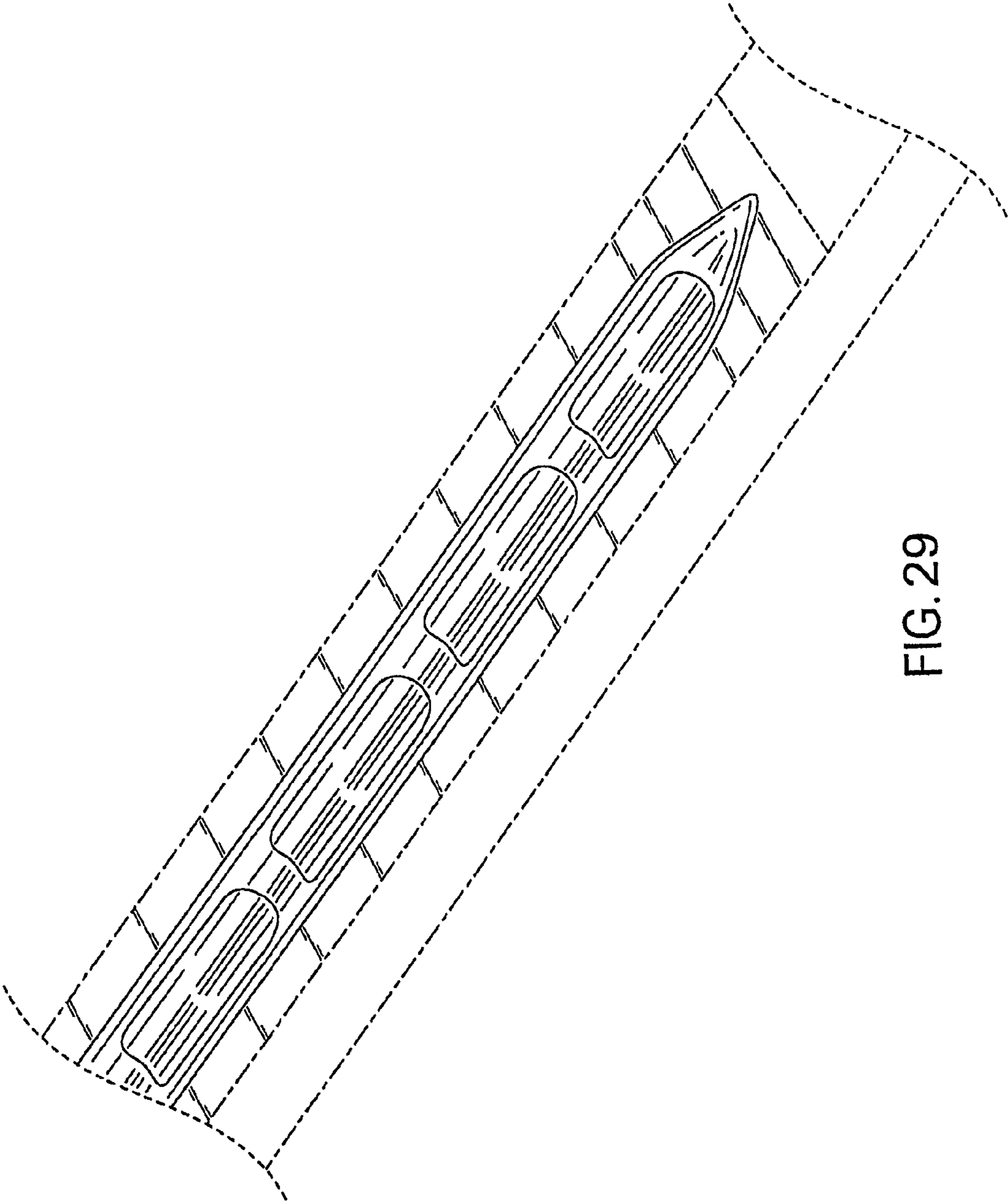

FIG. 29

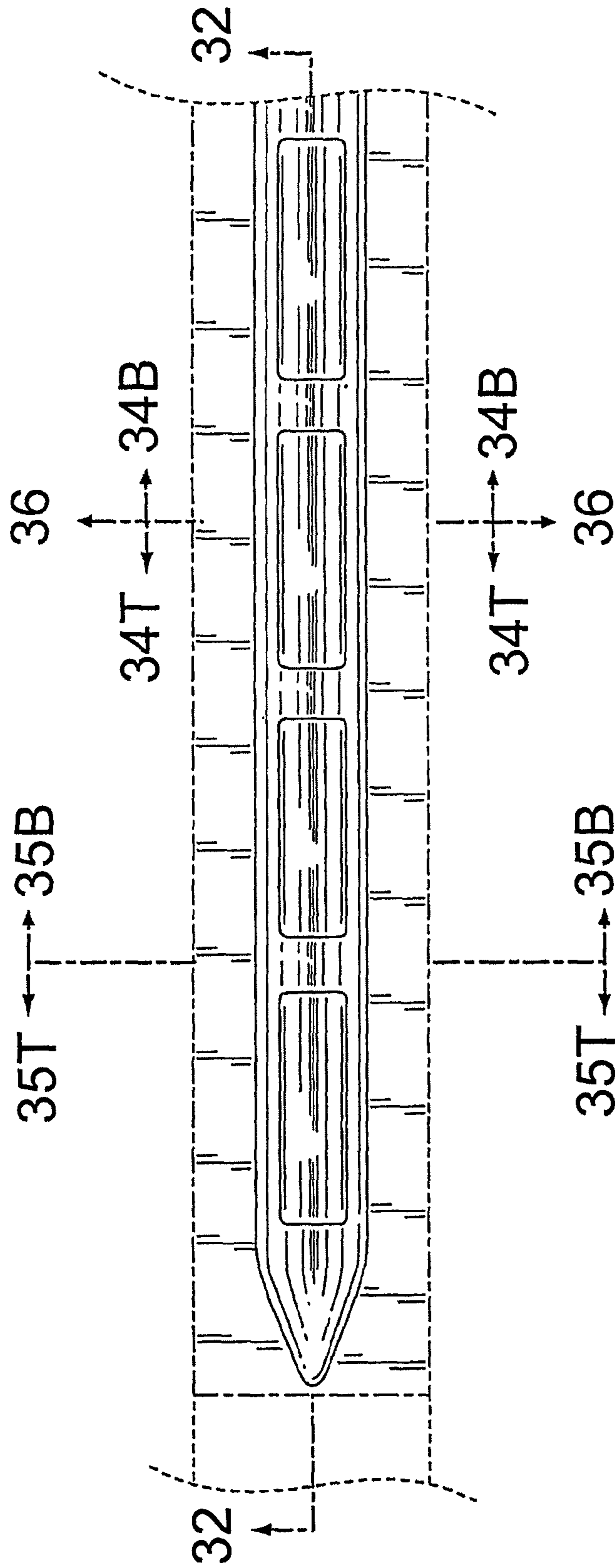

FIG. 30

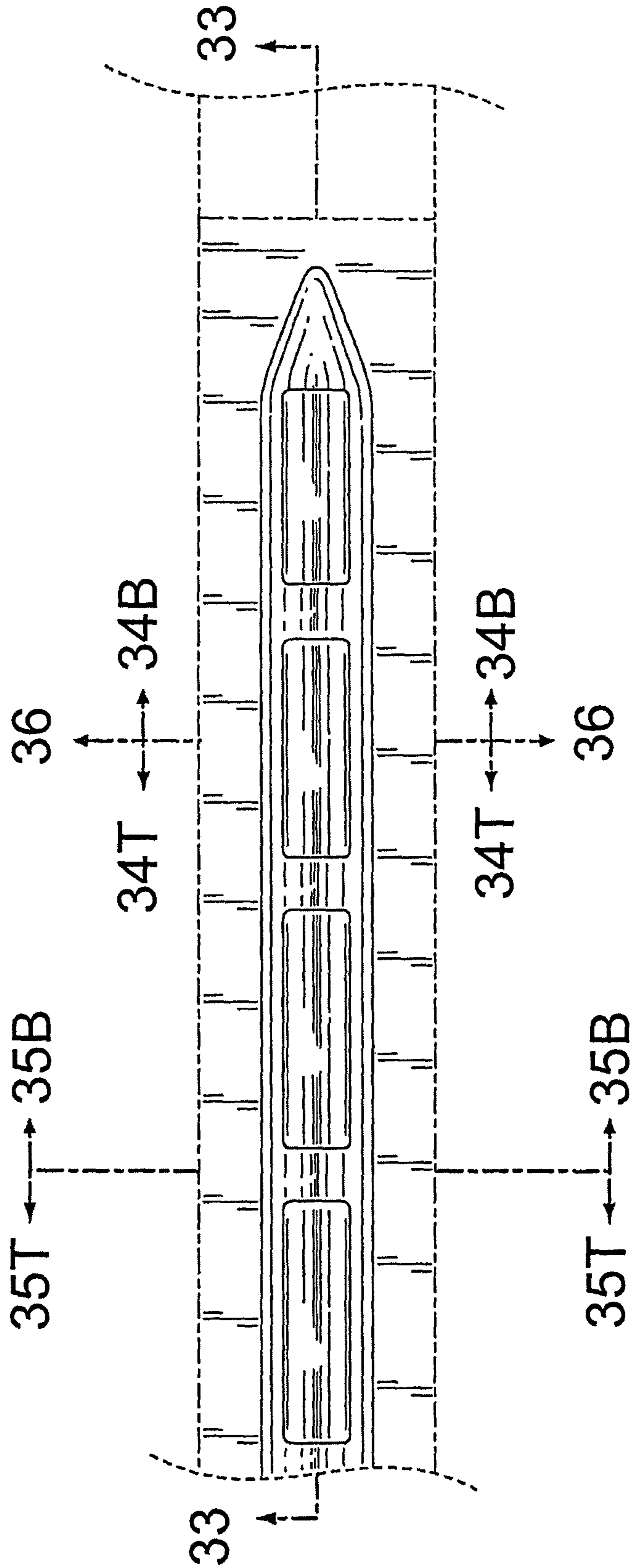

FIG. 31

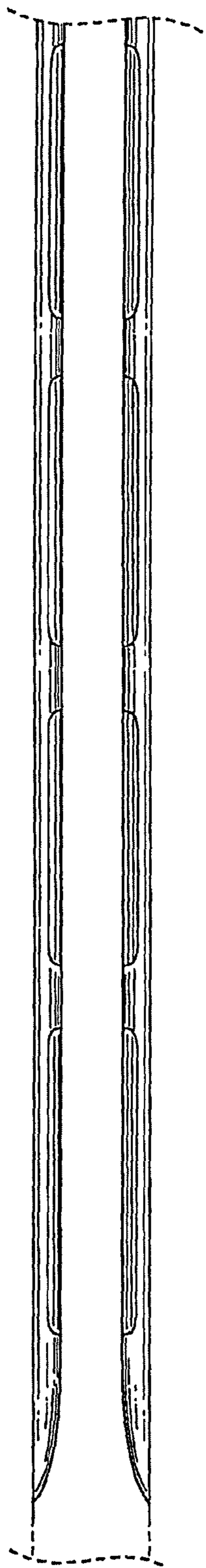

FIG. 32

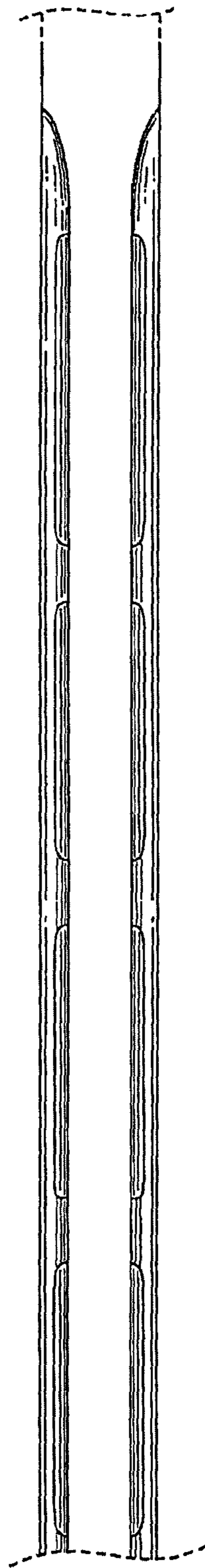

FIG. 33

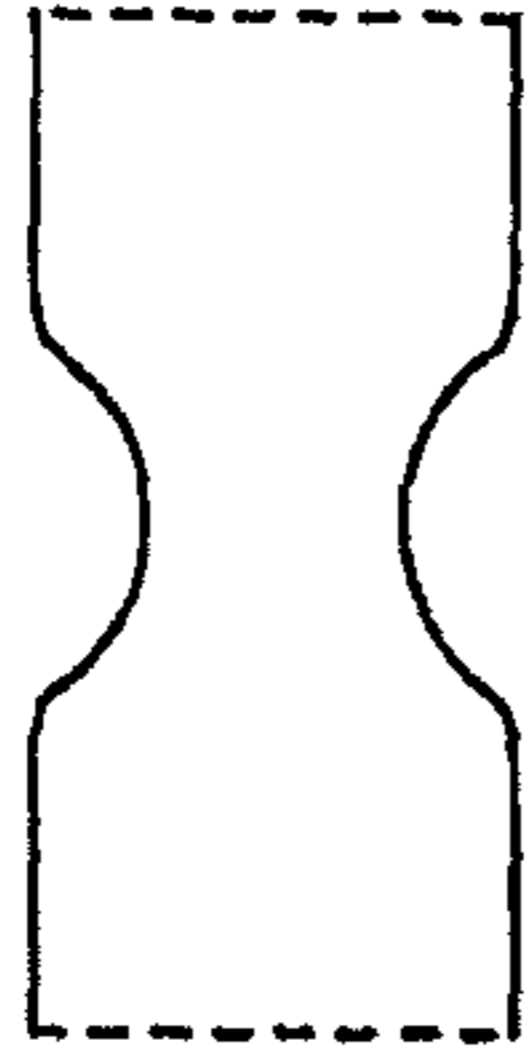

FIG. 36

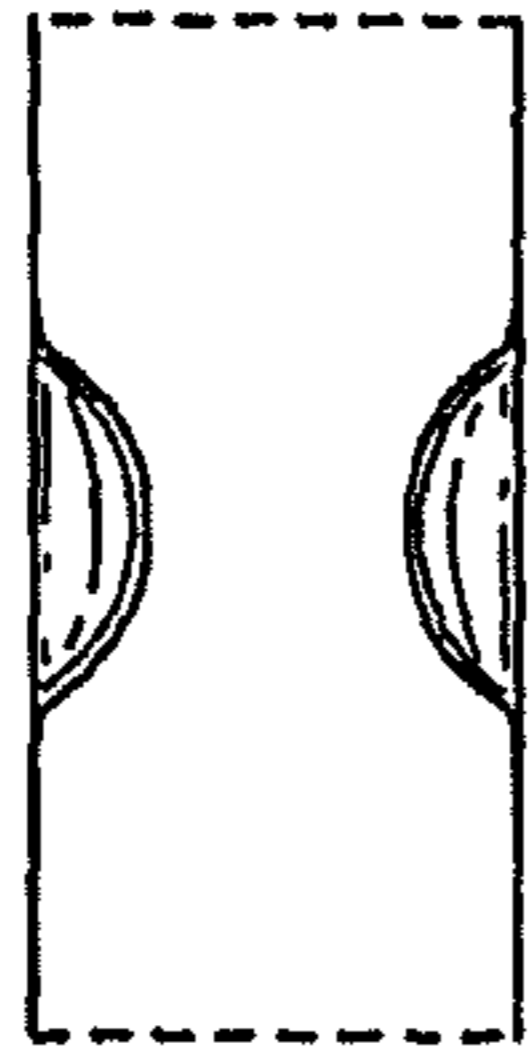

FIG. 35B

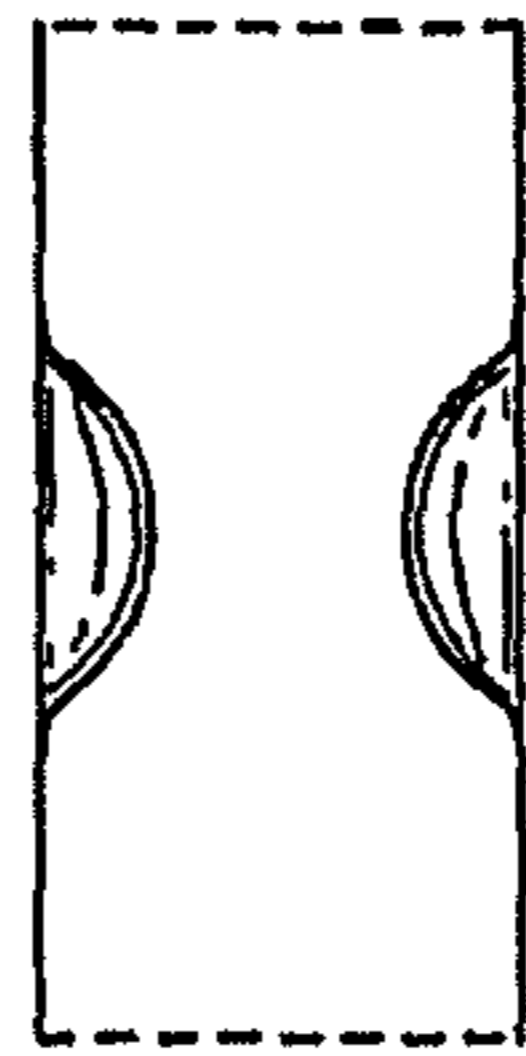

FIG. 35T

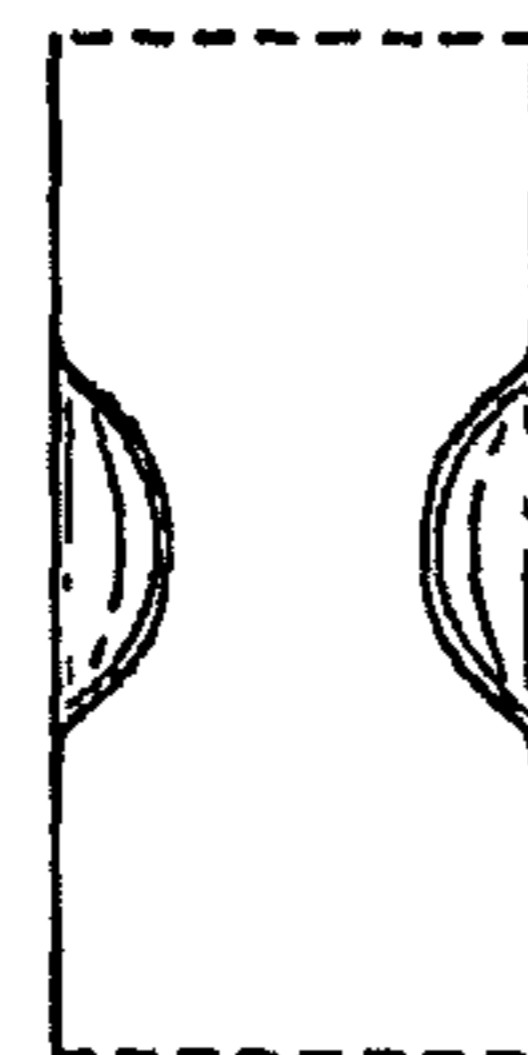

FIG. 34B

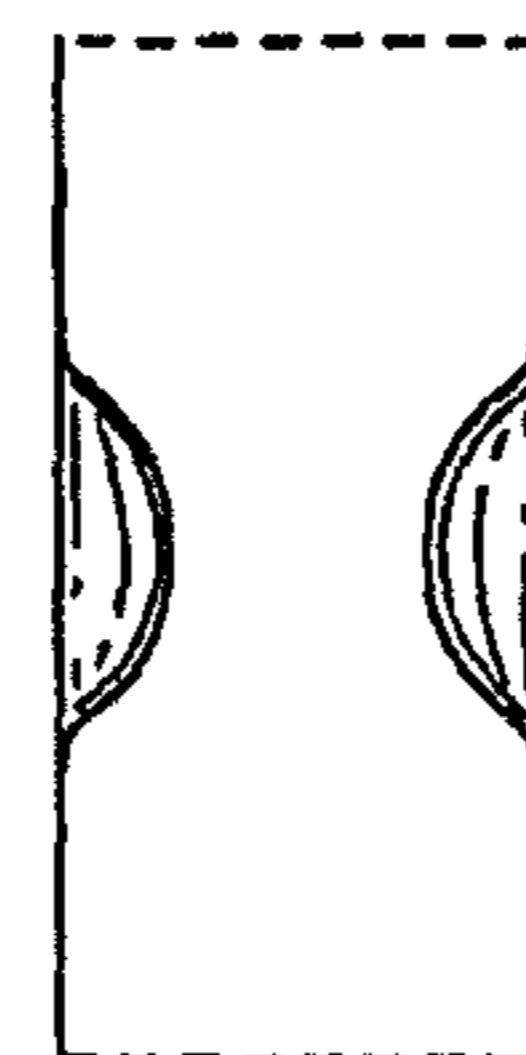

FIG. 34T