

US00D704102S

(12) **United States Design Patent**
Nurnberger

(10) **Patent No.:** **US D704,102 S**
(45) **Date of Patent:** **** May 6, 2014**

(54) **AUTOMOBILE, TOY REPLICA AND OTHER REPLICAS**

D686,553 S * 7/2013 Kwon et al. D12/196
D687,348 S * 8/2013 Nurnberger D12/92
D693,274 S * 11/2013 Tamatani et al. D12/92

(71) Applicant: **Aston Martin Lagonda Limited,**
Gaydon (GB)

FOREIGN PATENT DOCUMENTS

(72) Inventor: **Miles Nurnberger,** Gaydon (GB)

EM 000212923-0001 10/2004
EM 001999848-0001 2/2012
EM 002033621-0001 4/2012
GB 3013456 7/2003
GB 3024223 4/2006

(73) Assignee: **Aston Martin Lagonda Limited,**
Gaydon (GB)

* cited by examiner

(**) Term: **14 Years**

Primary Examiner — Melody Brown

(21) Appl. No.: **29/434,453**

(74) *Attorney, Agent, or Firm* — Dorsey & Whitney LLP

(22) Filed: **Oct. 12, 2012**

(57) **CLAIM**

I claim the ornamental design for an automobile, toy replica and/or other replicas, as shown and described.

(30) **Foreign Application Priority Data**

DESCRIPTION

May 25, 2012 (EM) 002047977-0001

(51) **LOC (10) Cl.** **12-08**

(52) **U.S. Cl.**
USPC **D12/92**

(58) **Field of Classification Search**
USPC D12/86, 90-92, 88; D21/424, 433, 434;
296/181.1, 181.5
See application file for complete search history.

FIG. 1 is a front perspective view of an automobile, toy replica and/or other replicas showing my new design; FIG. 2 is a rear perspective view of the automobile of FIG. 1; FIG. 3 is a top plan view of the automobile of FIG. 1. FIG. 4 is a bottom plan view of the automobile of FIG. 1. FIG. 5 is a left side elevation view of the automobile of FIG. 1. FIG. 6 is a right side elevation view of the automobile of FIG. 1. FIG. 7 is a front elevation view of the automobile of FIG. 1; and, FIG. 8 is a rear elevation view of the automobile of FIG. 1. The broken lines shown in the drawings are only for purposes of illustrating environment and defining the bounds of the claimed design and form no part of the claimed design.

(56) **References Cited**

U.S. PATENT DOCUMENTS

D620,396 S 7/2010 Reichman et al.
D629,718 S 12/2010 Reichman et al.
D629,725 S 12/2010 Reichman et al.
D630,140 S 1/2011 Reichman et al.
D664,895 S * 8/2012 Nakagami et al. D12/91
D686,531 S * 7/2013 Lamm D12/91

1 Claim, 7 Drawing Sheets

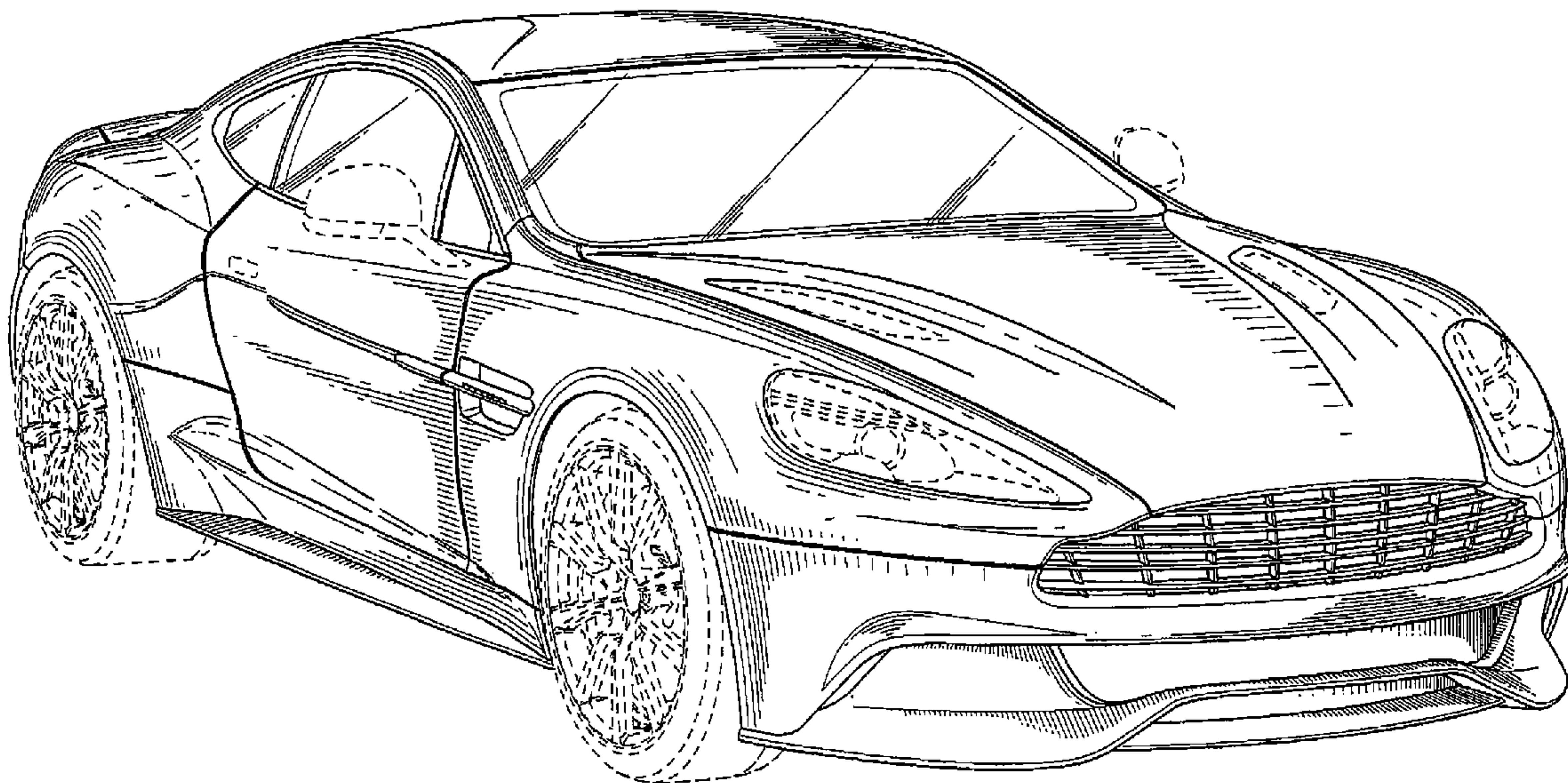

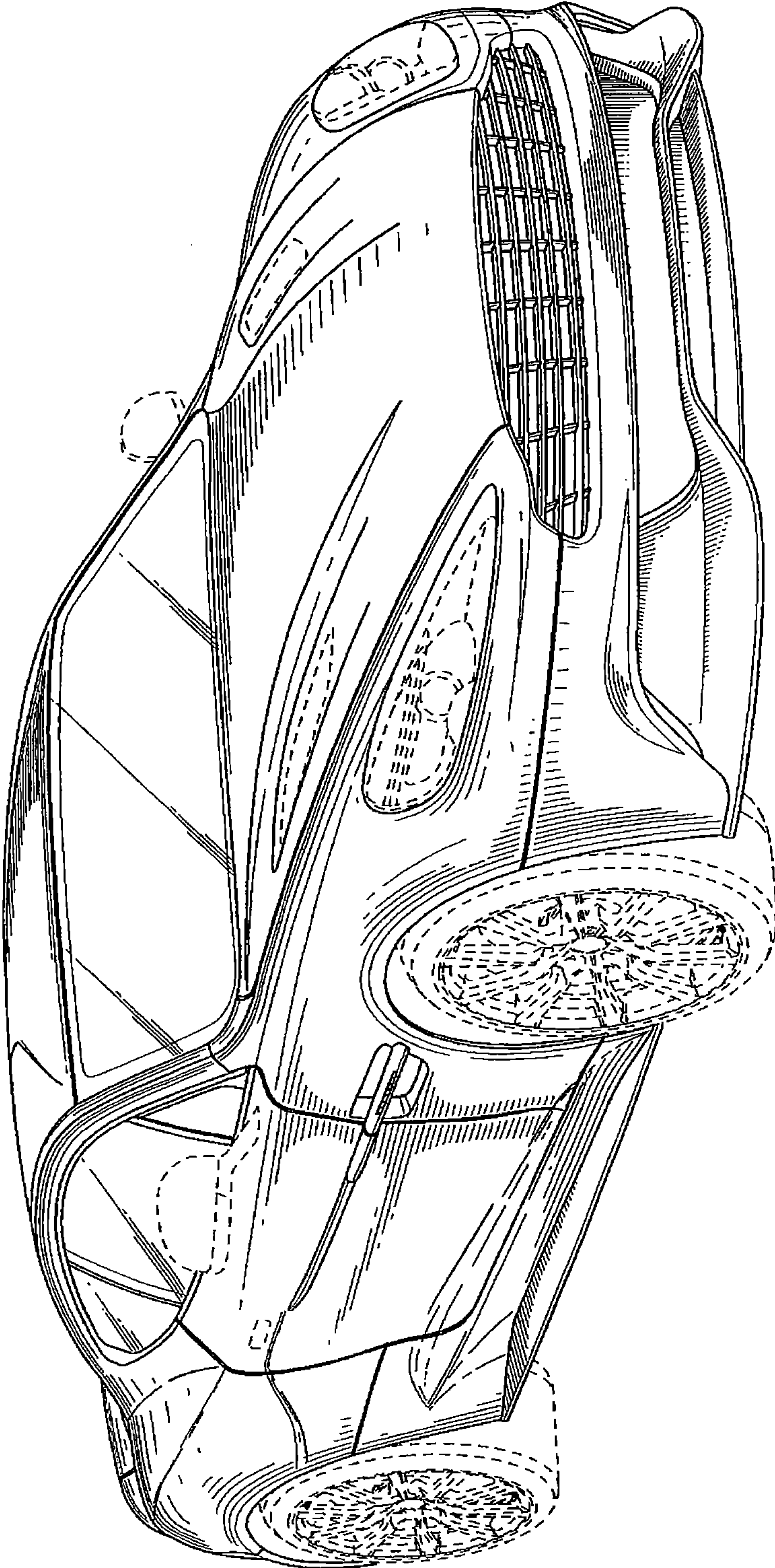

FIG. 1

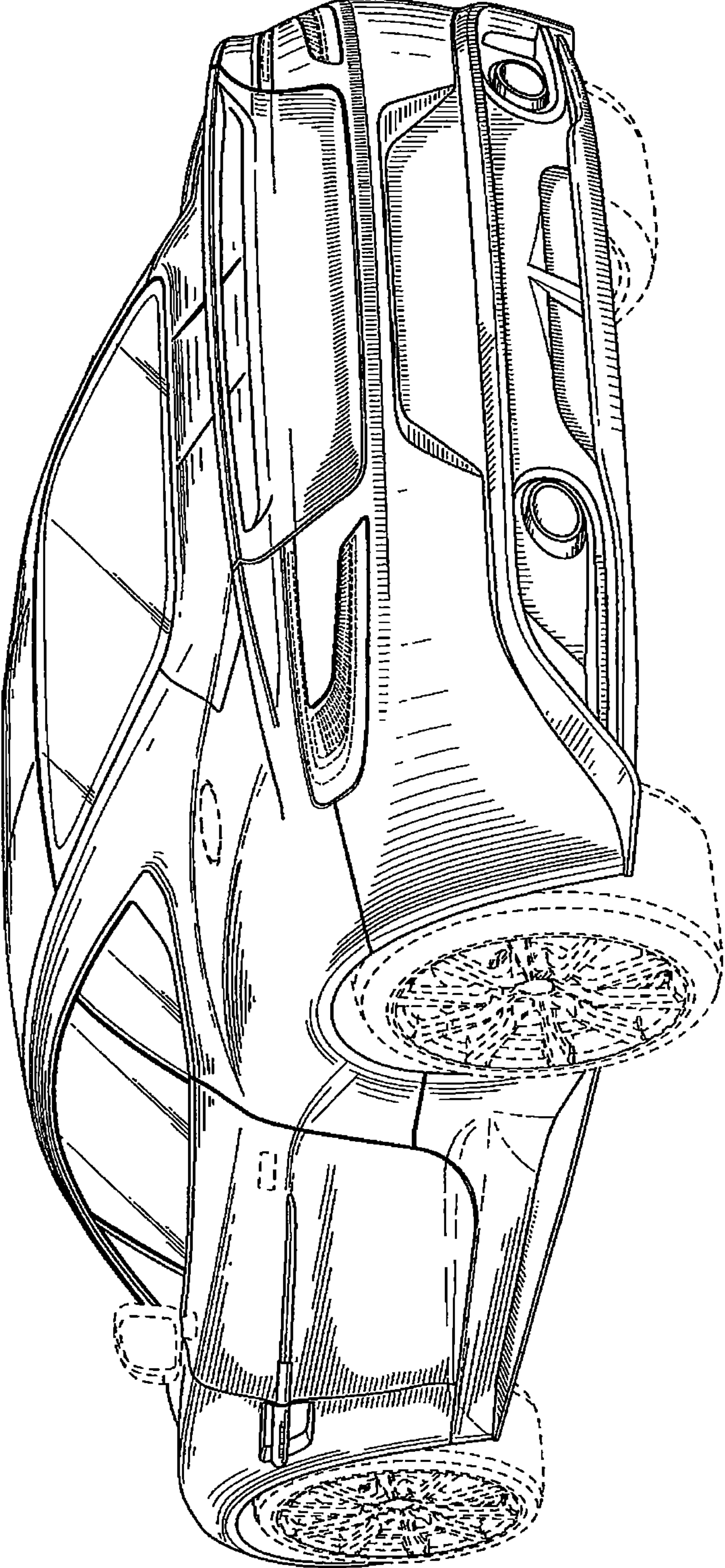

FIG. 2

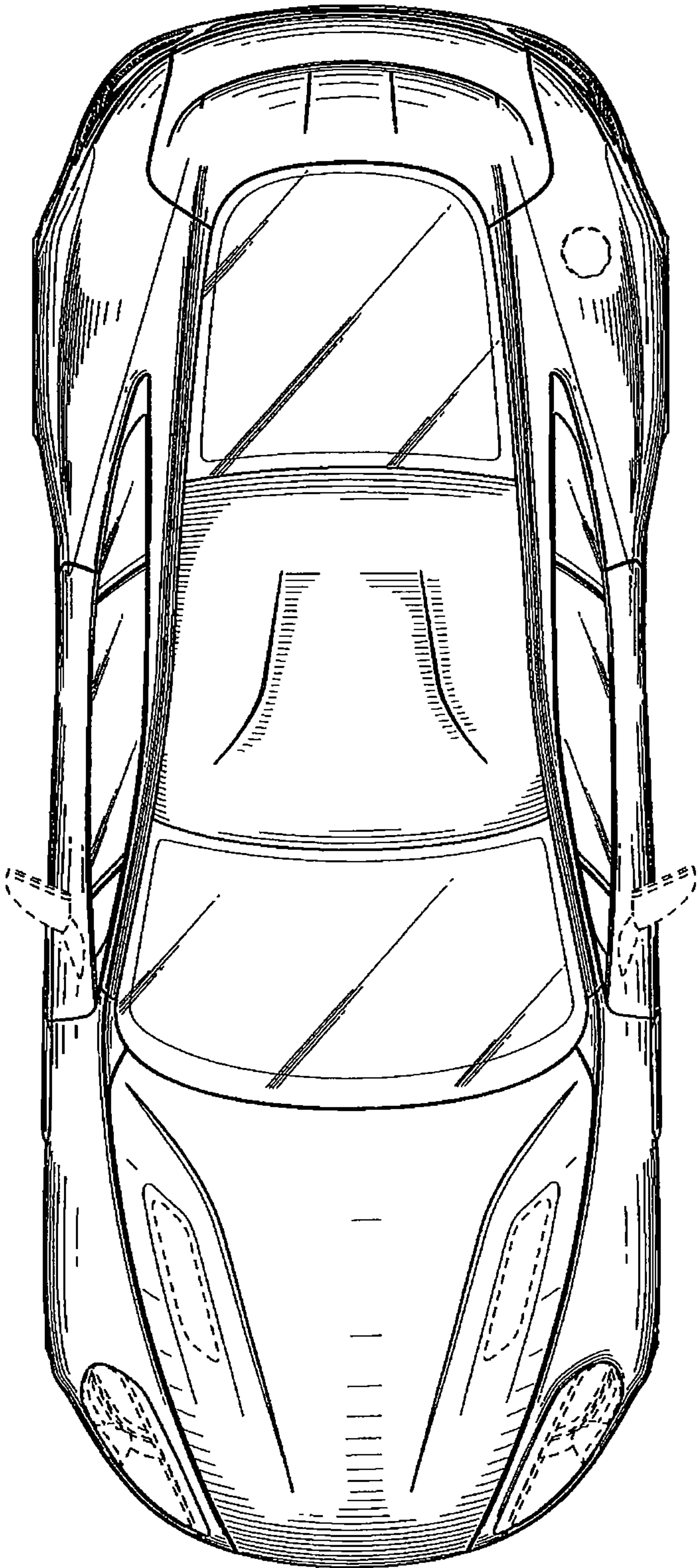

FIG. 3

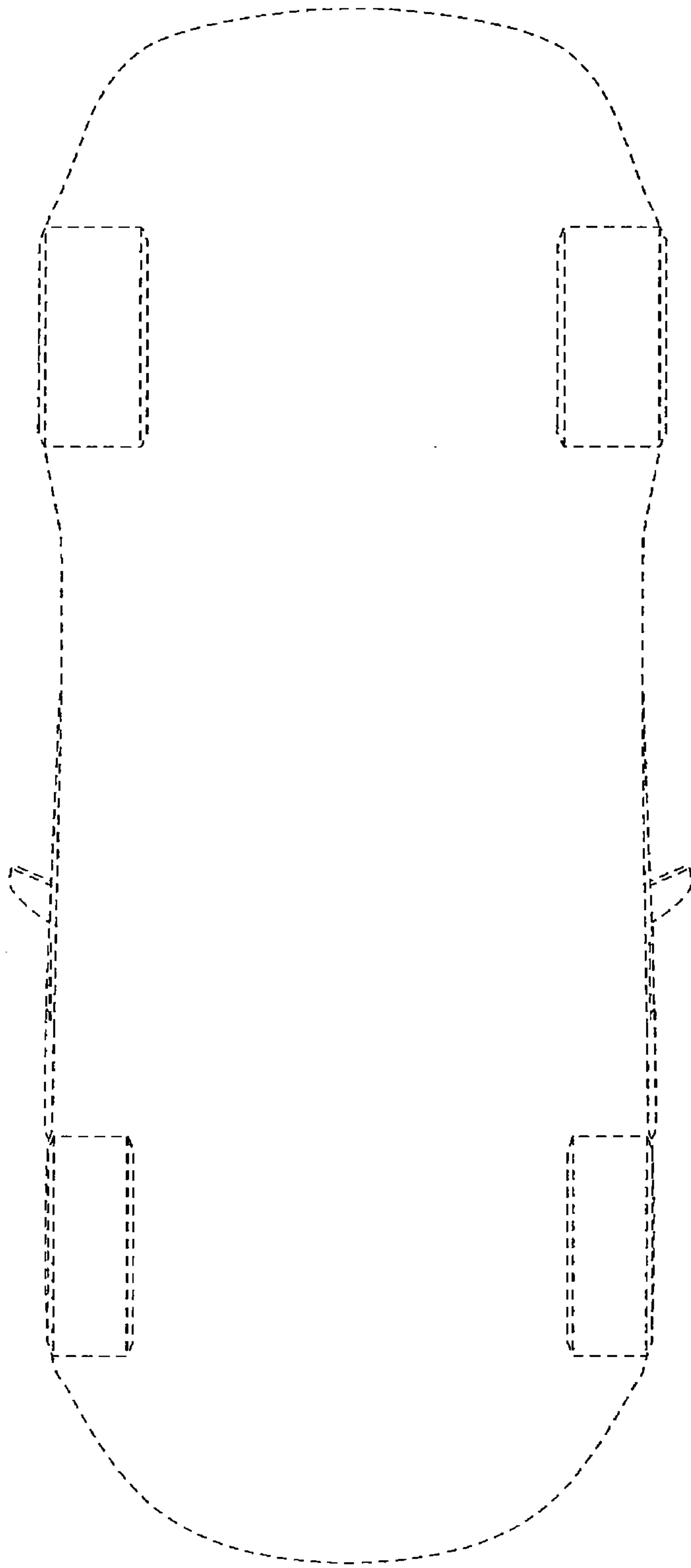

FIG. 4

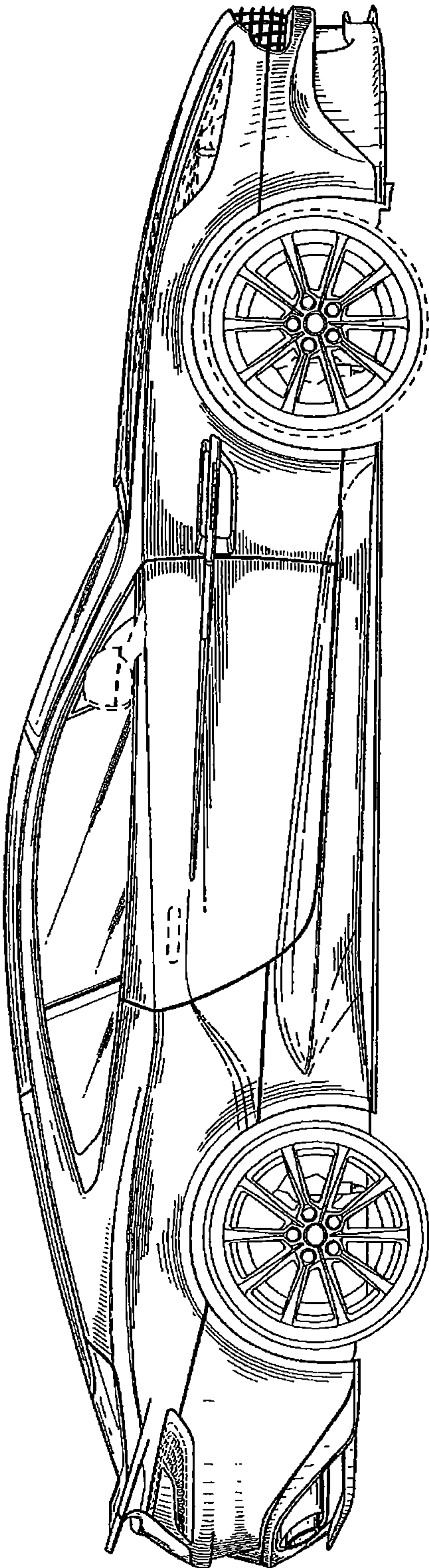

FIG. 5

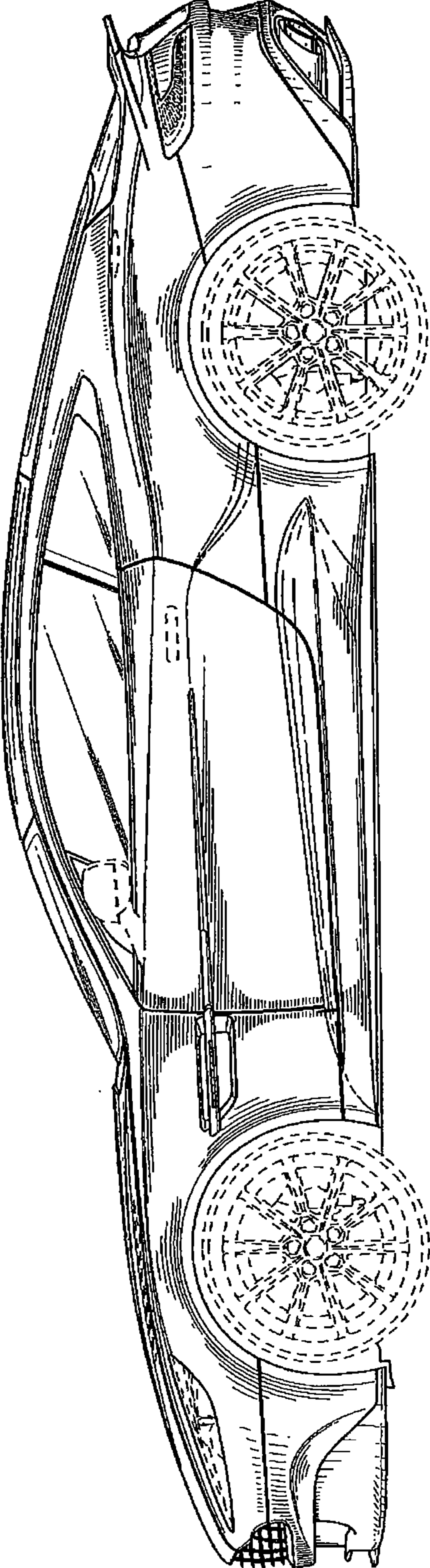

FIG. 6

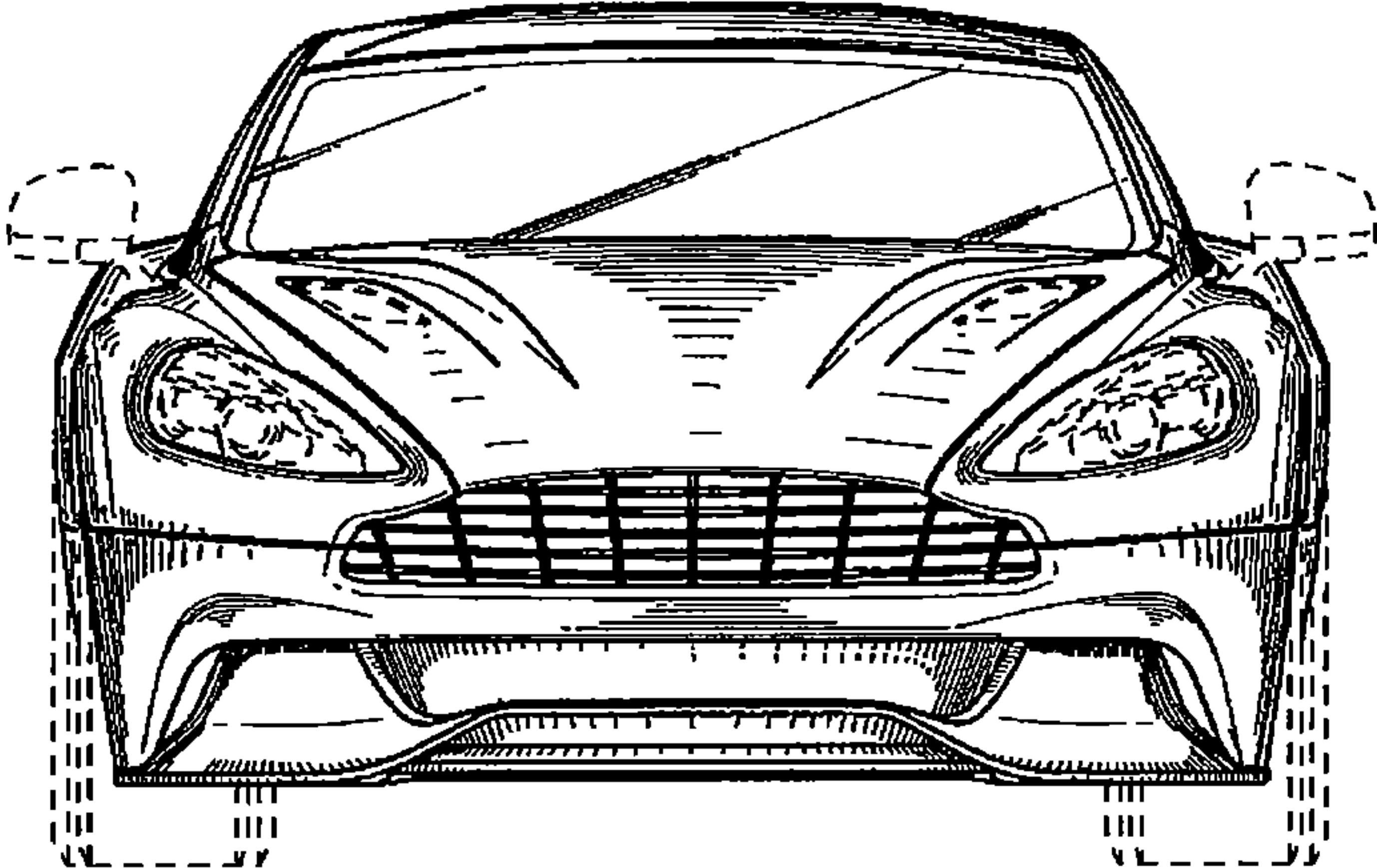

FIG. 7

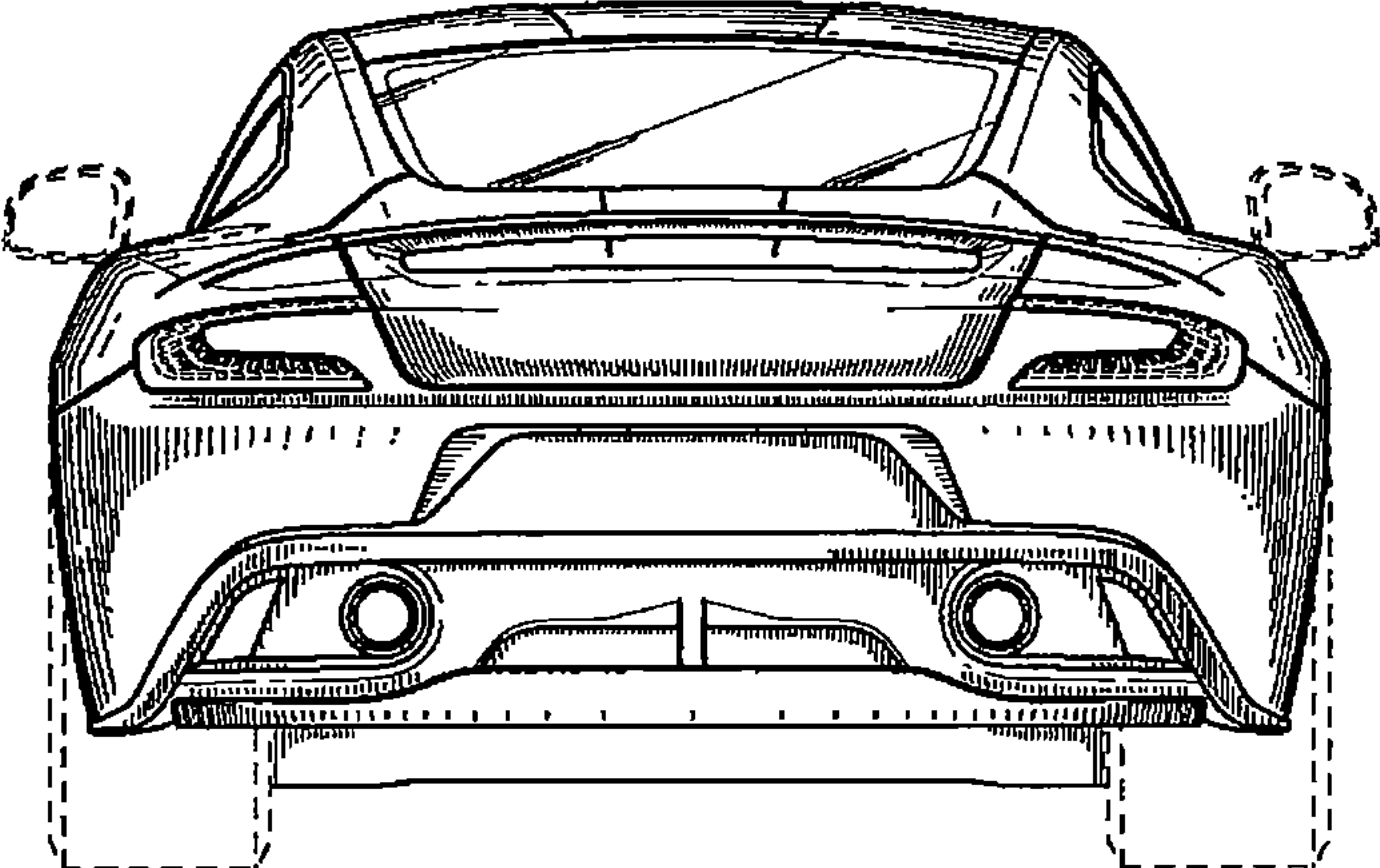

FIG. 8