



US00D704083S

(12) **United States Design Patent**  
**Rusch**

(10) **Patent No.:** **US D704,083 S**

(45) **Date of Patent:** **\*\* May 6, 2014**

(54) **MARKER FOR PERMEABLE PAVER**

(75) Inventor: **David P. Rusch**, Springville, CA (US)

(73) Assignee: **National Diversified Sales, Inc.**,  
Woodland Hills, CA (US)

(\*\*) Term: **14 Years**

(21) Appl. No.: **29/416,939**

(22) Filed: **Mar. 28, 2012**

(51) **LOC (10) Cl.** ..... **10-05**

(52) **U.S. Cl.**  
USPC ..... **D10/109.1**

(58) **Field of Classification Search**  
USPC ..... D10/109.1, 109.2, 113.1; 404/14;  
D20/22; D8/1; 473/150; 47/47; 15/237  
See application file for complete search history.

(56) **References Cited**

**U.S. PATENT DOCUMENTS**

70,076 A	10/1867	Dean
1,905,176 A	4/1933	Kieckhefer
2,315,180 A	3/1943	Arthur
2,315,448 A	3/1943	Nagin et al.
2,899,775 A	8/1959	Partin
2,912,910 A	11/1959	Wilson et al.
3,438,312 A	4/1969	Becker
3,597,928 A	8/1971	Pilaar
3,764,446 A	10/1973	Martin
3,802,144 A	4/1974	Spica
3,903,702 A	9/1975	Appleton
3,960,375 A	6/1976	Bibi-Roubi
4,008,548 A	2/1977	Leclerc
4,111,585 A	9/1978	Mascaro

4,167,599 A	9/1979	Nissinen	
D270,820 S *	10/1983	Schulze	D10/109.1
4,584,221 A	4/1986	Kung	
4,621,942 A	11/1986	Hill	
D288,792 S *	3/1987	Jefferies	D10/113.1
4,671,699 A	6/1987	Roach	
4,798,498 A	1/1989	Hallberg et al.	
5,250,340 A	10/1993	Bohnhoff	
5,287,649 A	2/1994	Prestele	
5,406,745 A	4/1995	Lin	
5,564,854 A *	10/1996	Hedgewick	404/14
5,689,912 A	11/1997	Prestele	
7,210,876 B2	5/2007	Moralez et al.	
7,563,052 B2	7/2009	Van Reijen	
7,568,980 B1	8/2009	Janus et al.	

\* cited by examiner

*Primary Examiner* — George D Kirschbaum

(74) *Attorney, Agent, or Firm* — Fulwider Patton LLP

(57) **CLAIM**

The ornamental design for a marker for permeable paver, as shown and described.

**DESCRIPTION**

FIG. 1 is a perspective view showing my new design;  
FIG. 2 is a top view thereof;  
FIG. 3 is a bottom view thereof;  
FIG. 4 is back view thereof;  
FIG. 5 is a front view thereof;  
FIG. 6 is a left view thereof; and,  
FIG. 7 is a side view thereof.

The broken lines show environmental structure, and form no part of my invention.

**1 Claim, 4 Drawing Sheets**

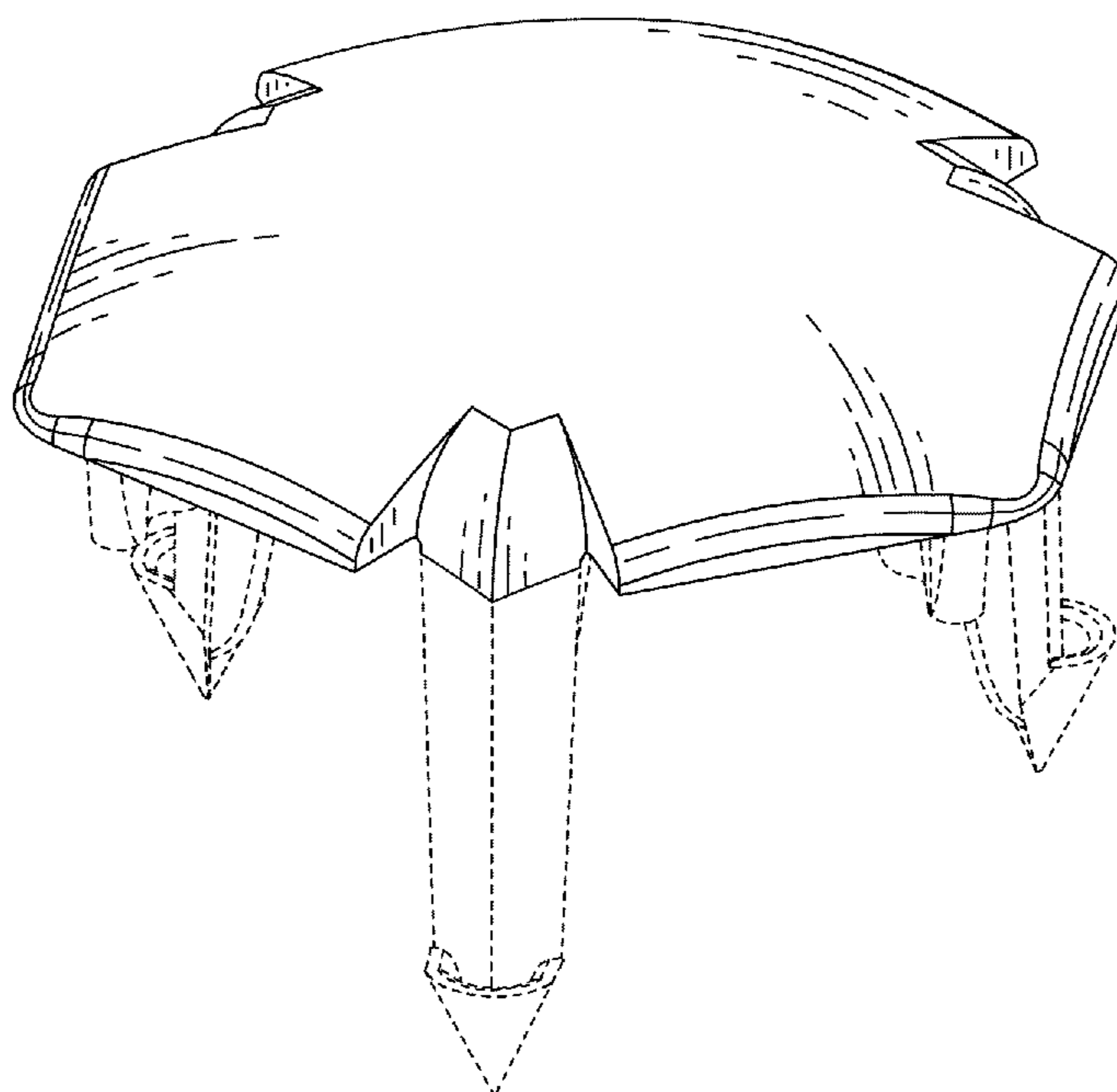

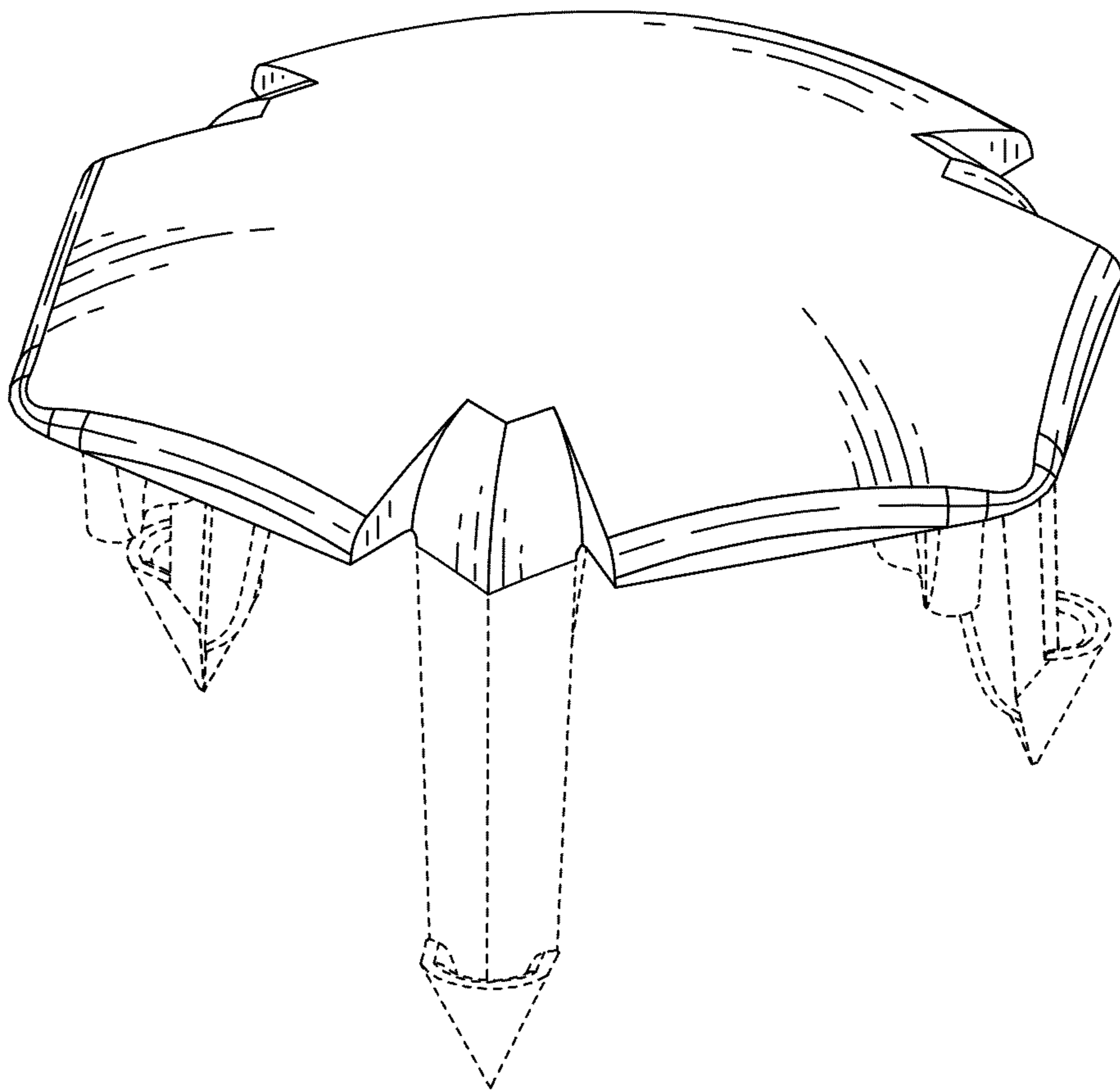

FIG. 1

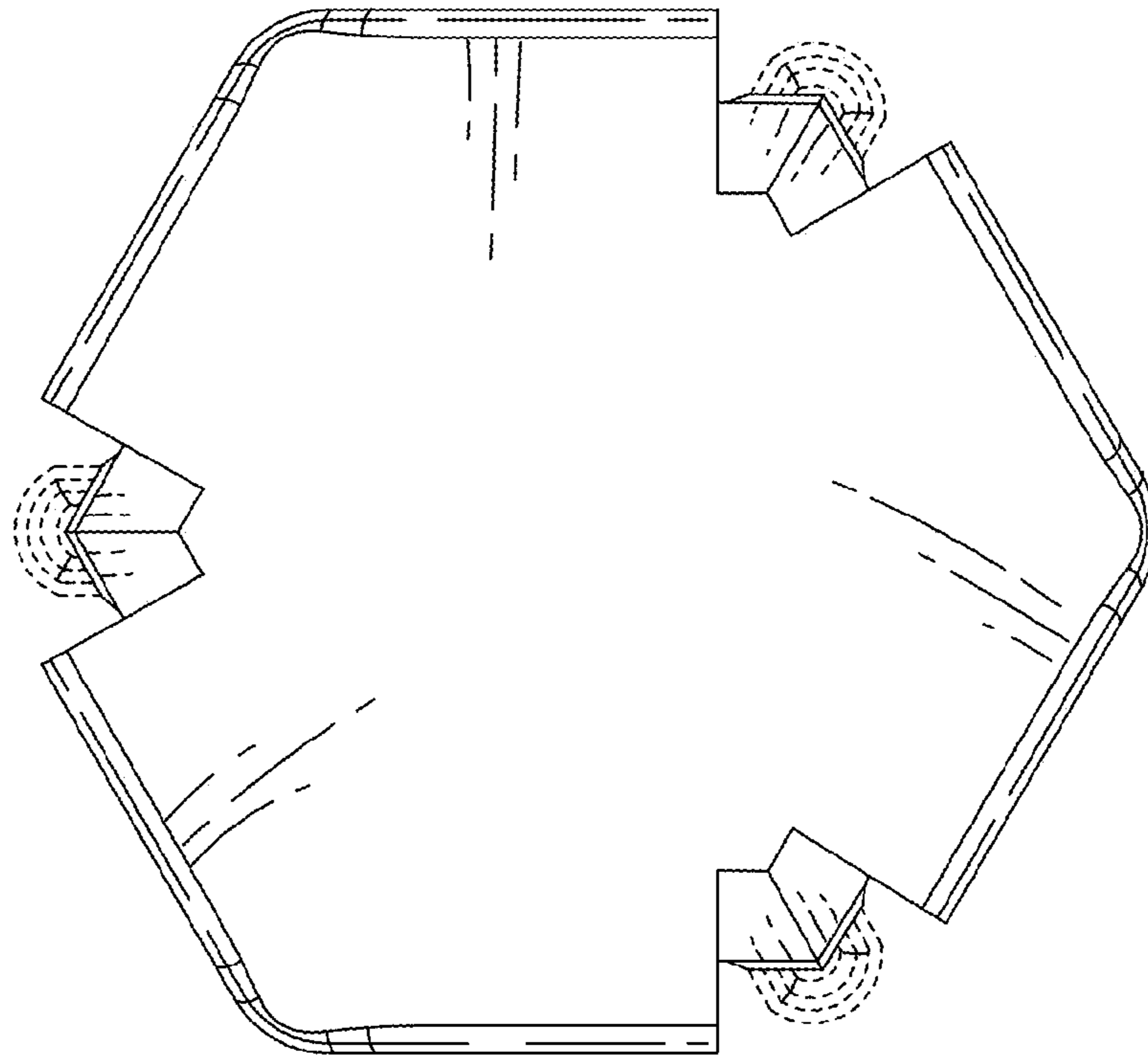

FIG. 2

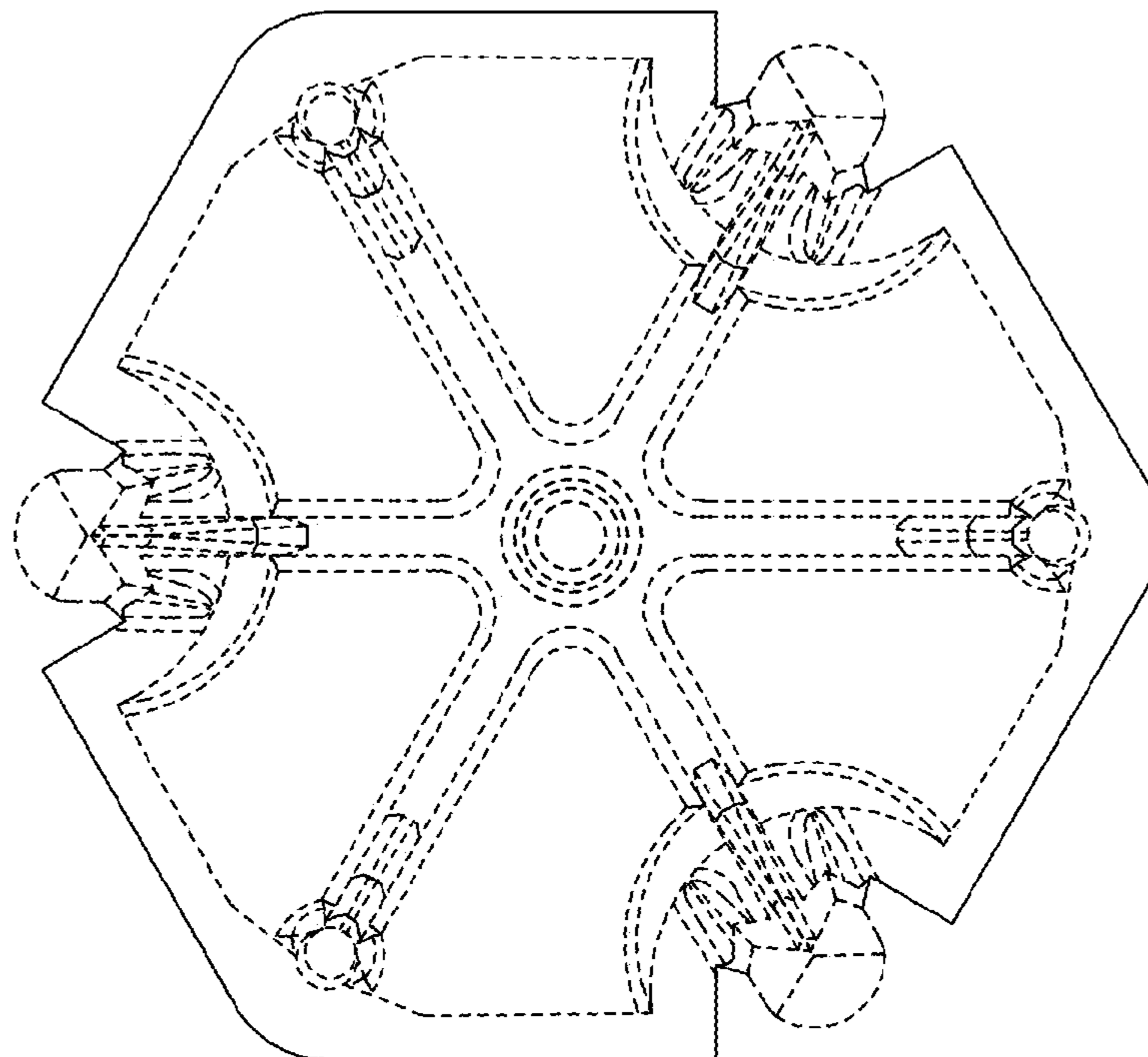

FIG. 3

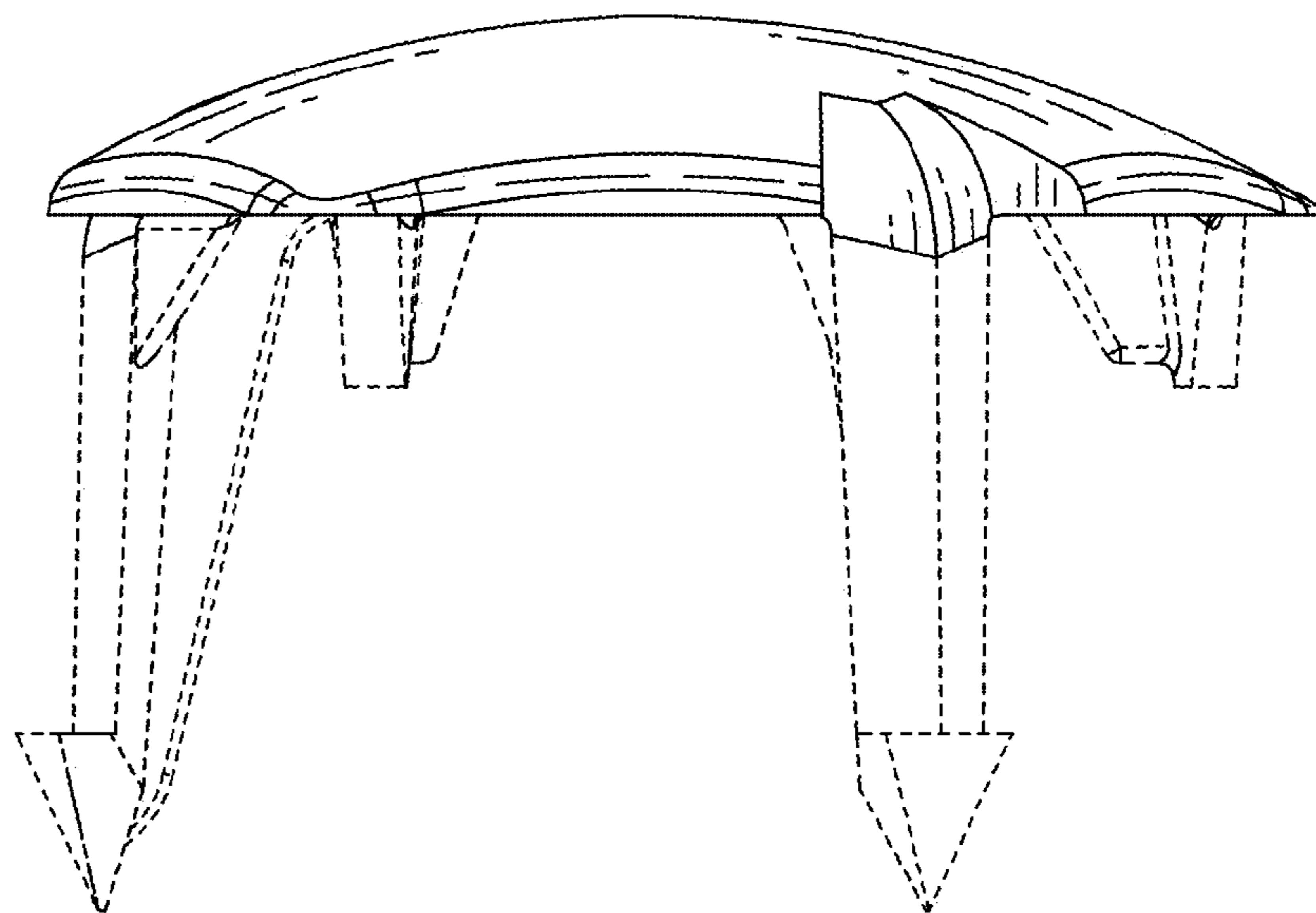

FIG. 4

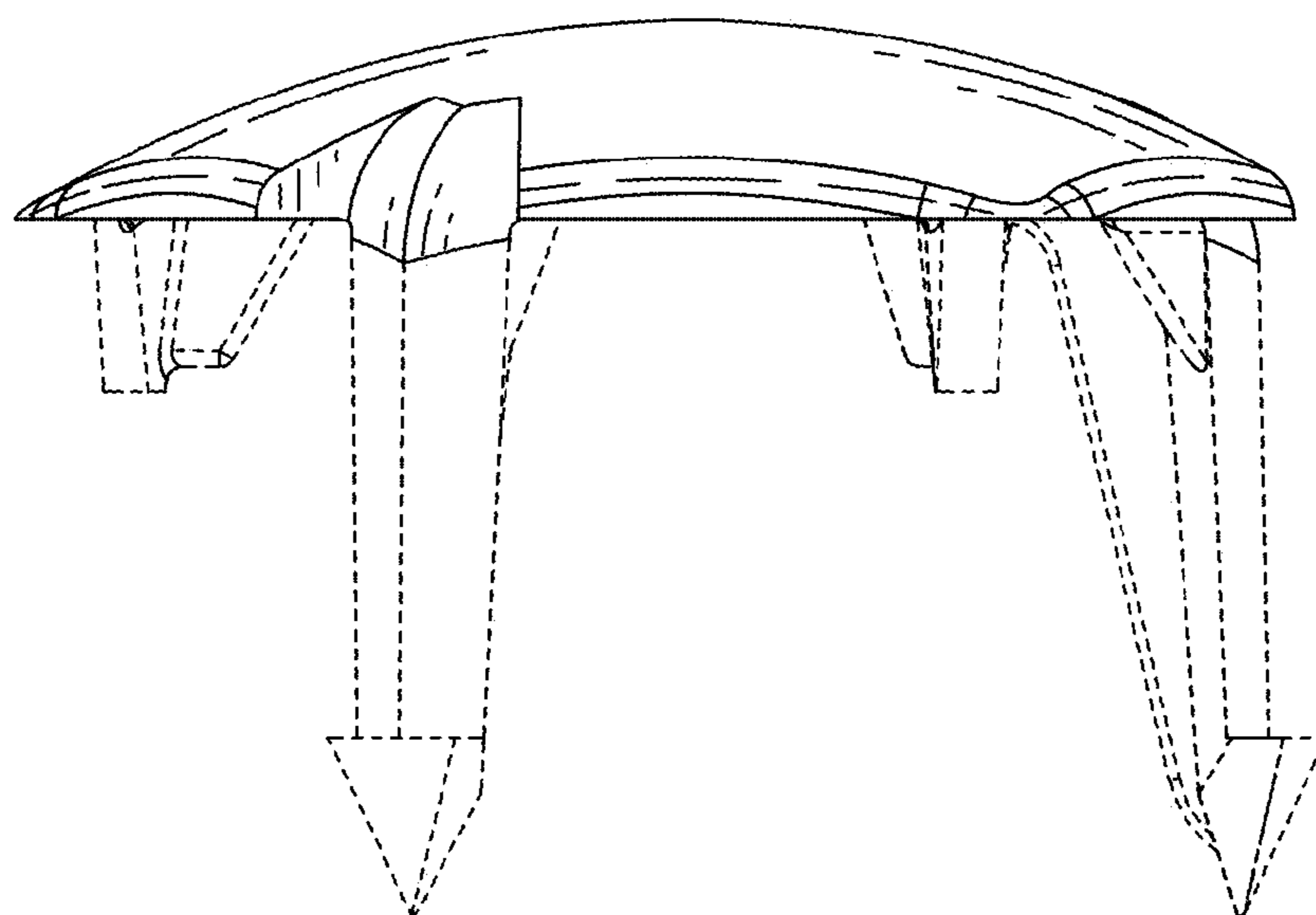

FIG. 5

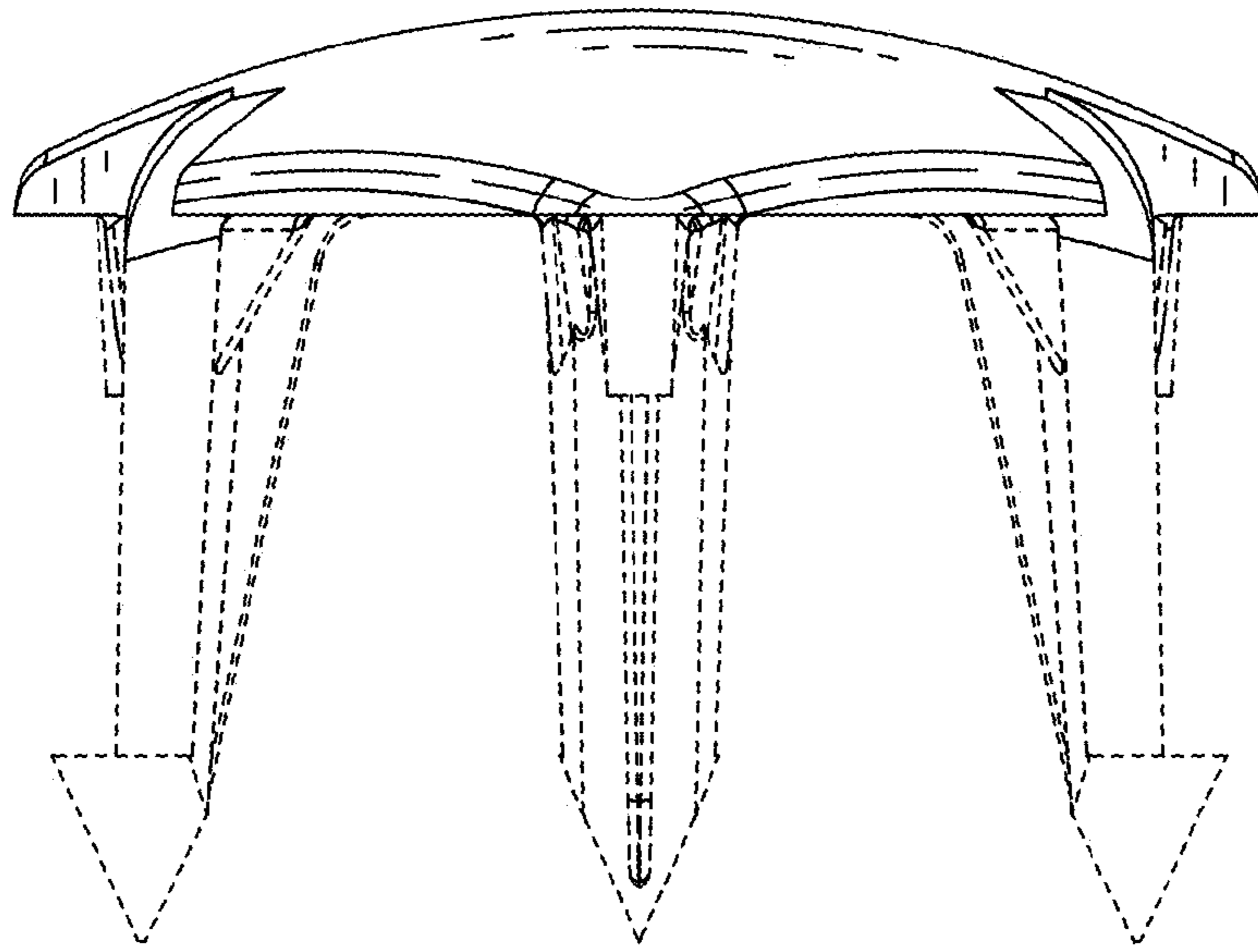

FIG. 6

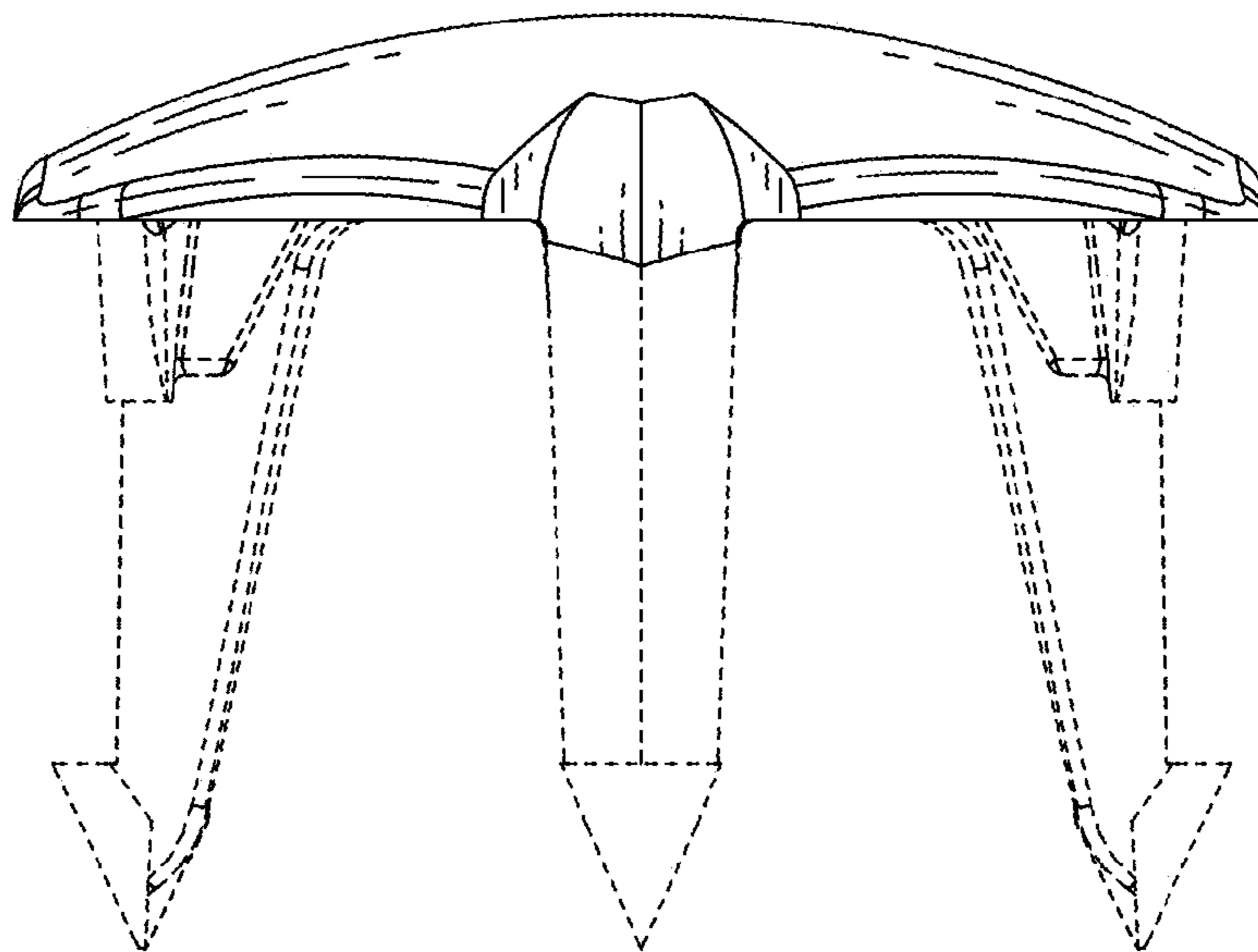

FIG. 7