



US00D703588S

(12) **United States Design Patent**
Wyers

(10) **Patent No.:** **US D703,588 S**

(45) **Date of Patent:** **** Apr. 29, 2014**

(54) **ADJUSTABLE DRAW BAR FOR TRAILER HITCHES**

(76) Inventor: **Philip Wyers**, Centennial, CO (US)

(**) Term: **14 Years**

(21) Appl. No.: **29/348,985**

(22) Filed: **Feb. 27, 2010**

(51) **LOC (10) Cl.** **12-16**

(52) **U.S. Cl.**
USPC **D12/162**

(58) **Field of Classification Search**
USPC D12/162; D25/119, 121; 280/490.1,
280/478.1, 495, 186, 402-403, 405, 407,
280/482, 511, 405.1, 407.1, 416.2, 455,
280/491.5

See application file for complete search history.

(56) **References Cited**

U.S. PATENT DOCUMENTS

414,090	A *	10/1889	Taylor	72/468
3,610,447	A *	10/1971	Ortiz	294/81.56
5,975,553	A *	11/1999	Van Vleet	280/483
D468,453	S *	1/2003	Schrader	D25/121
D475,144	S *	5/2003	Thornton et al.	D25/119
D476,089	S *	6/2003	Fenstermacher	D25/38.1
6,824,156	B2 *	11/2004	Smith	280/490.1
6,902,181	B1 *	6/2005	Dye	280/478.1

D576,722	S *	9/2008	Nishio et al.	D23/393
7,559,570	B2 *	7/2009	Cearns	280/490.1
D660,458	S *	5/2012	Thornton	D25/102
2004/0032112	A1 *	2/2004	Reese et al.	280/477
2009/0295123	A1 *	12/2009	Good	280/490.1
2011/0062121	A1 *	3/2011	Van Strien	219/75
2012/0112433	A1 *	5/2012	Williams et al.	280/490.1

* cited by examiner

Primary Examiner — T. Chase Nelson

Assistant Examiner — Ania Aman

(57) **CLAIM**

The ornamental design for a adjustable draw bar for trailer hitches, as shown and described.

DESCRIPTION

FIG. 1 is a rear perspective view of an adjustable draw bar for trailer hitches showing my new design.

FIG. 2 is a rear elevation view.

FIG. 3 is a front elevation view

FIG. 4 is a top plan view

FIG. 5 is a right elevation view; and,

FIG. 6 is a bottom plan view.

The broken lines in FIG. 1 depict environmental structure associated with the design in a condition of use. The broken lines and structures they depict form no part of the claimed design.

1 Claim, 2 Drawing Sheets

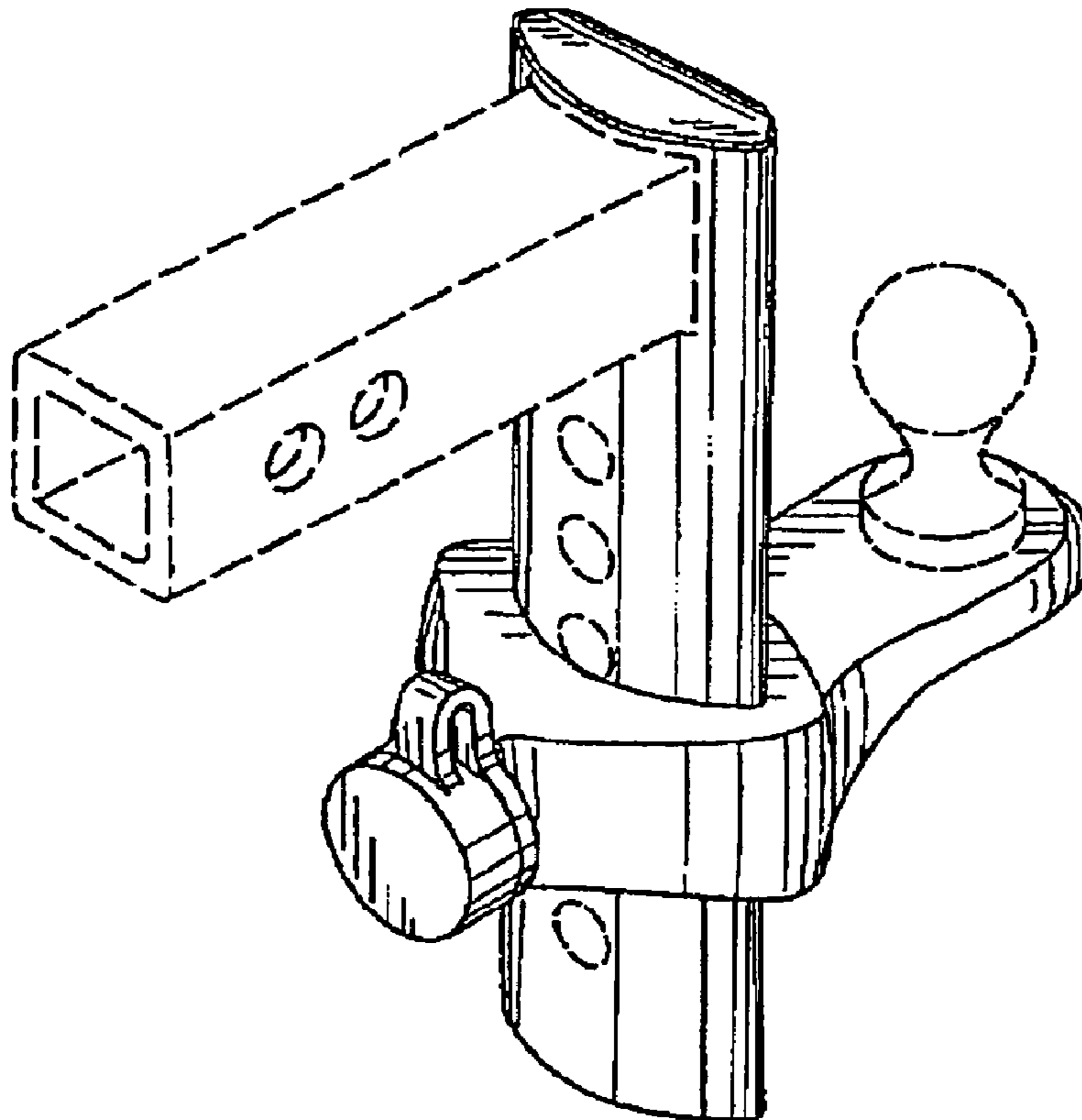

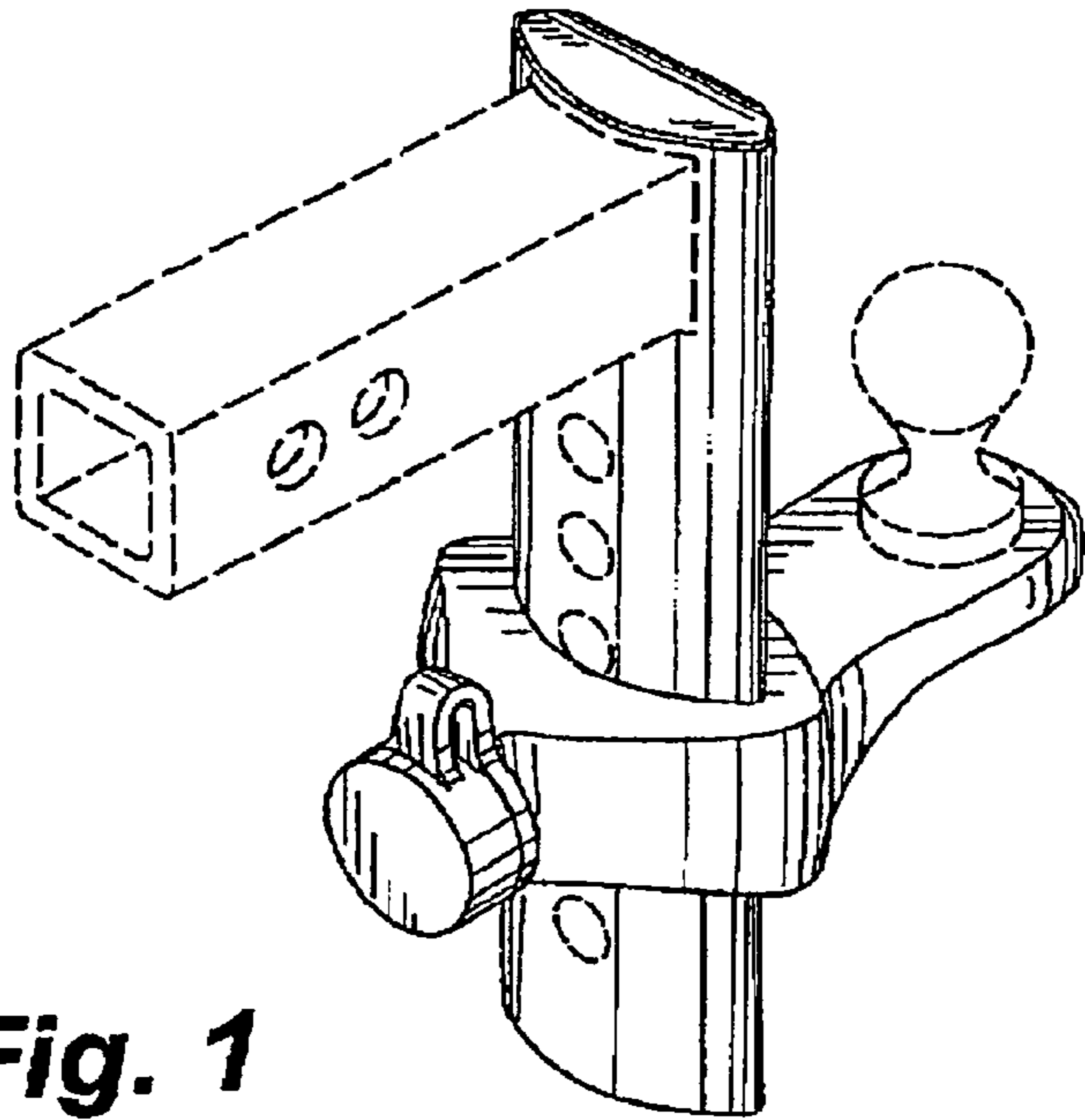

Fig. 1

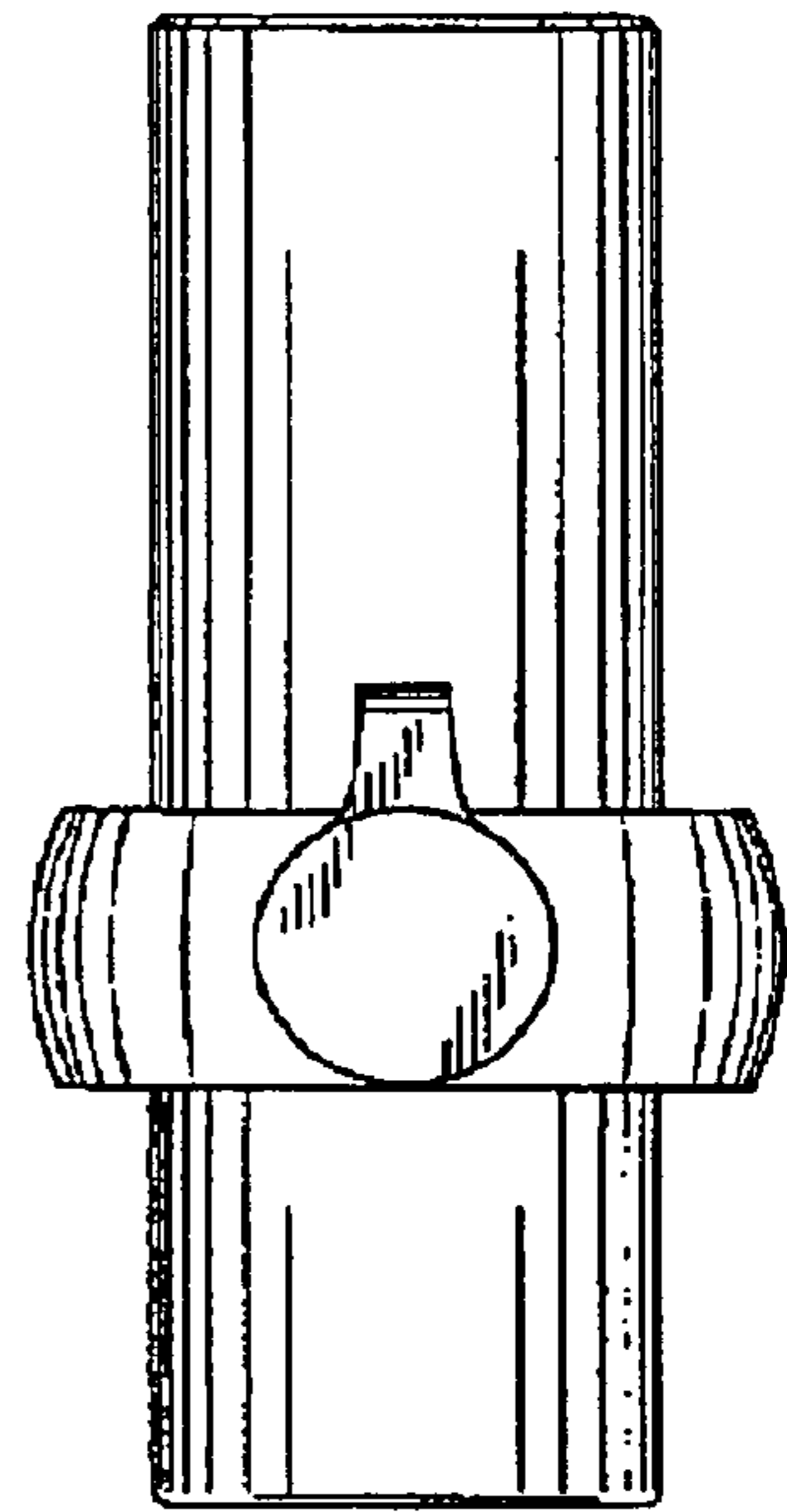

Fig. 2

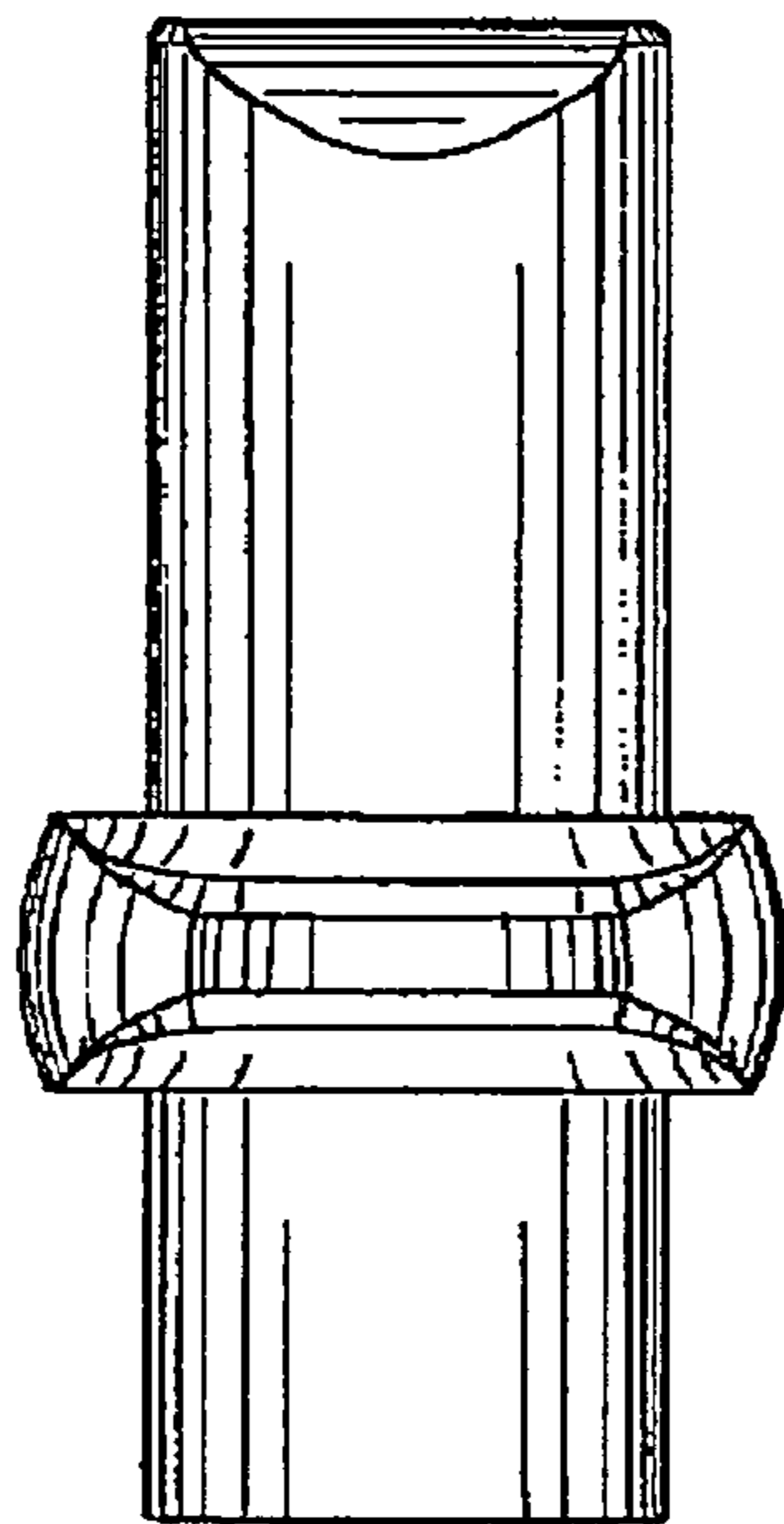

Fig. 3

Fig. 4

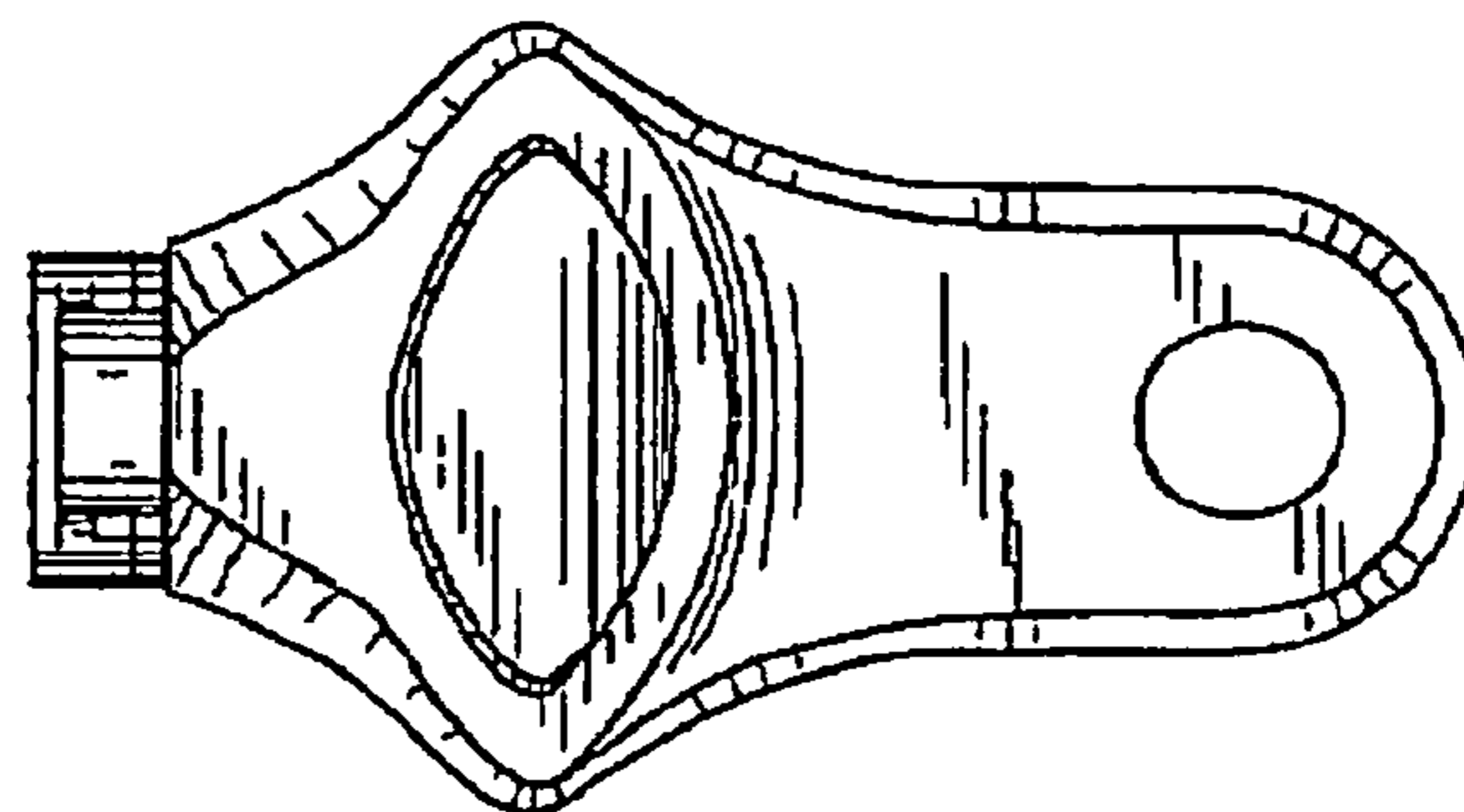

Fig. 5

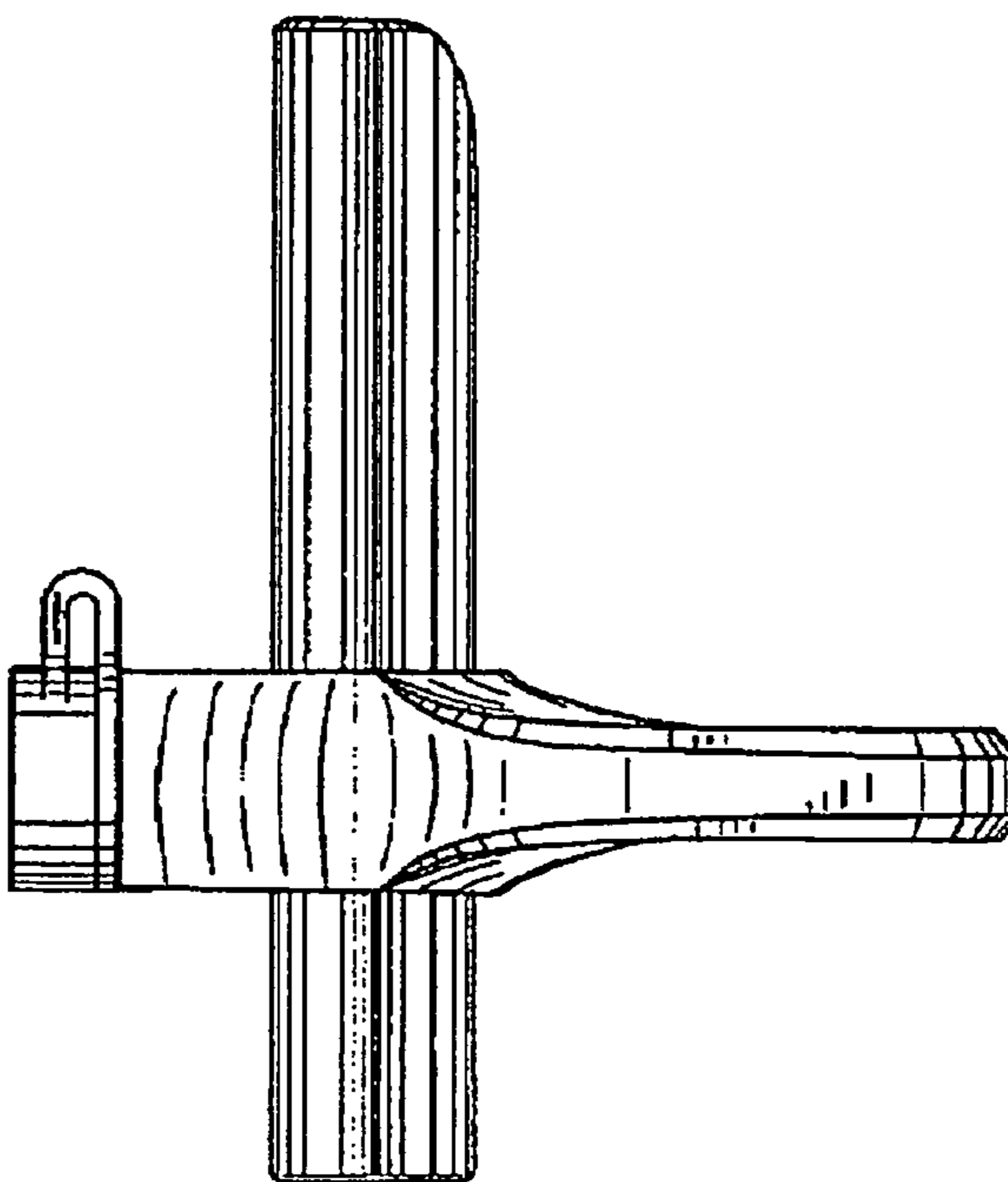

Fig. 6

