



US00D703534S

(12) **United States Design Patent**
Yamada

(10) **Patent No.:** **US D703,534 S**
(45) **Date of Patent:** **** Apr. 29, 2014**

(54) **LID FOR A CONTAINER**

(76) Inventor: **Kikuo Yamada**, Tokyo (JP)

(**) Term: **14 Years**

(21) Appl. No.: **29/406,579**

(22) Filed: **Nov. 16, 2011**

(30) **Foreign Application Priority Data**

May 24, 2011 (JP) 2011-011615

(51) **LOC (10) Cl.** **09-07**

(52) **U.S. Cl.**
CPC **A47K 10/421** (2013.01); **B65D 83/0835**
(2013.01)
USPC **D9/447**; D9/449

(58) **Field of Classification Search**
USPC D9/449, 447, 438, 435, 434, 734, 730,
D9/417; D7/510, 511, 396.2, 392.1;
229/906.1; 220/812, 713, 268, 254.9,
220/254.3, 253; D6/518; 221/63
See application file for complete search history.

(56) **References Cited**

U.S. PATENT DOCUMENTS

D307,555 S *	5/1990	Haenni et al.	D9/447
D444,063 S *	6/2001	Buck et al.	D9/447
D471,456 S *	3/2003	Young et al.	D9/447
D531,499 S *	11/2006	Zaidman	D9/434
D531,897 S *	11/2006	Evans et al.	D9/435
D671,426 S *	11/2012	Pickens et al.	D9/734

2005/0205594 A1 *	9/2005	Evans et al.	221/63
2006/0180596 A1 *	8/2006	Young et al.	221/63
2007/0210098 A1 *	9/2007	Evans et al.	221/63

* cited by examiner

Primary Examiner — Robert M Spear
(74) *Attorney, Agent, or Firm* — Oliff PLC

(57) **CLAIM**

The ornamental design for a lid for a container, as shown and described.

DESCRIPTION

FIG. 1 is a front view of a lid for a container showing my new design;
FIG. 2 is a rear view thereof;
FIG. 3 is a right side view thereof;
FIG. 4 is a left side view thereof;
FIG. 5 is a top plane view thereof with a cover in a closed position;
FIG. 6 is a top plane view thereof with a cover in an open position;
FIG. 7 is a bottom view thereof;
FIG. 8 is a sectional view taken along line 8-8 in FIG. 6;
FIG. 9 is a sectional view taken along line 9-9 in FIG. 6; and,
FIG. 10 is a perspective view showing the lid of a container of FIG. 1 in a state of use.

The unevenly spaced broken lines consisting of a long and short dash depict the bounds of the claim, whereas the evenly spaced broken lines depict environmental subject matter. None of the broken lines form a part of the claimed design.

1 Claim, 10 Drawing Sheets

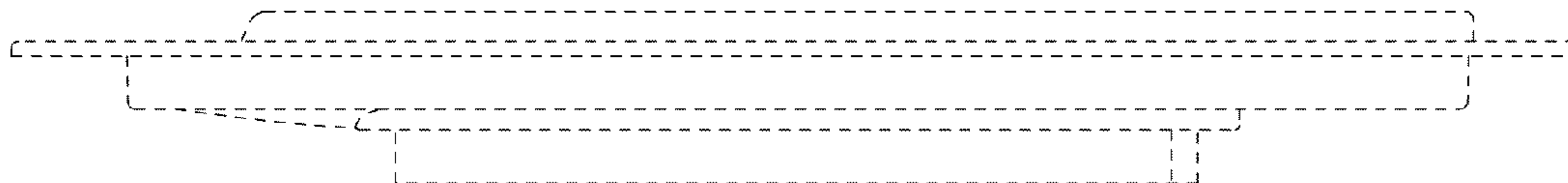

Fig. 1

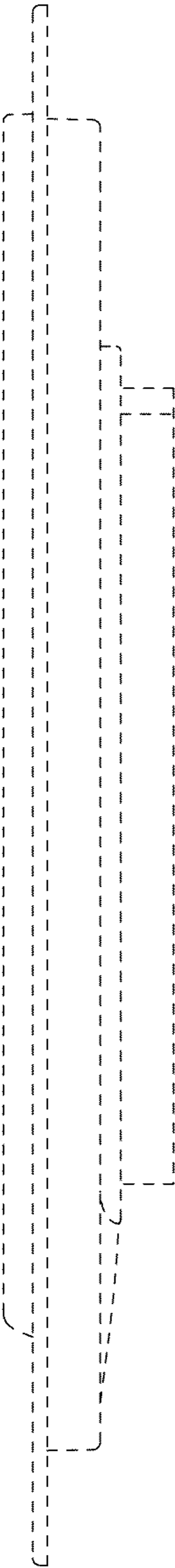

Fig. 2

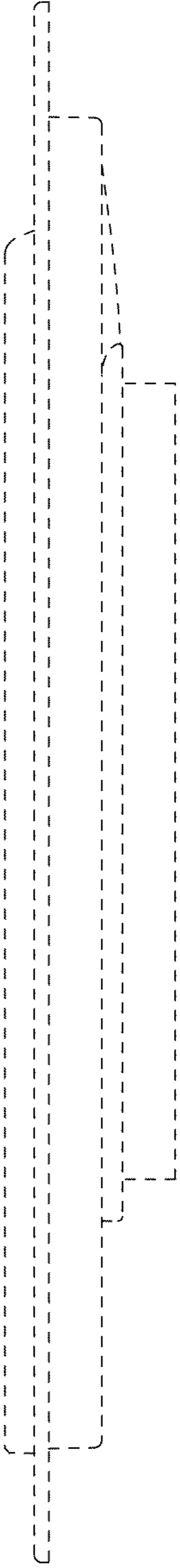

Fig. 3

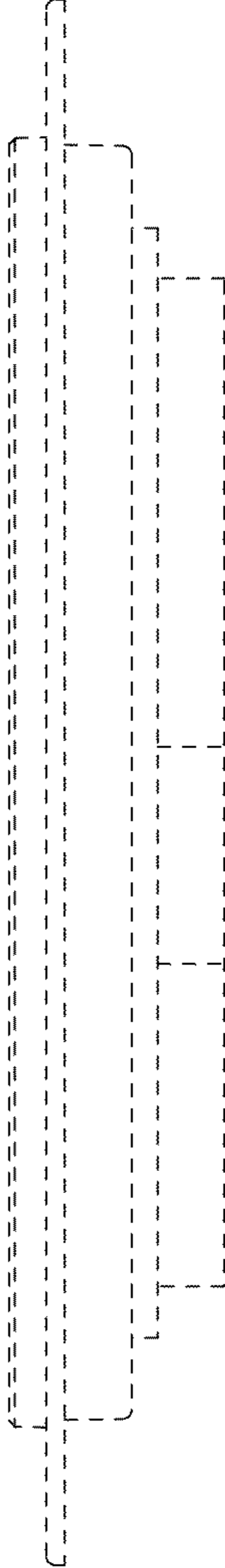
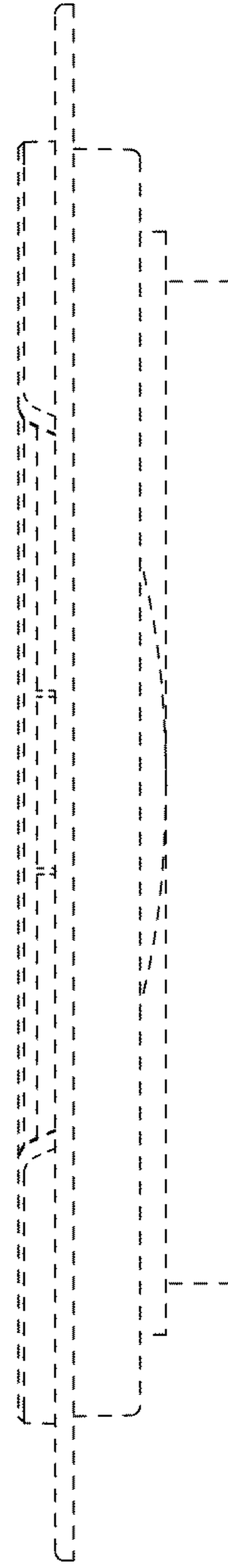

Fig. 4



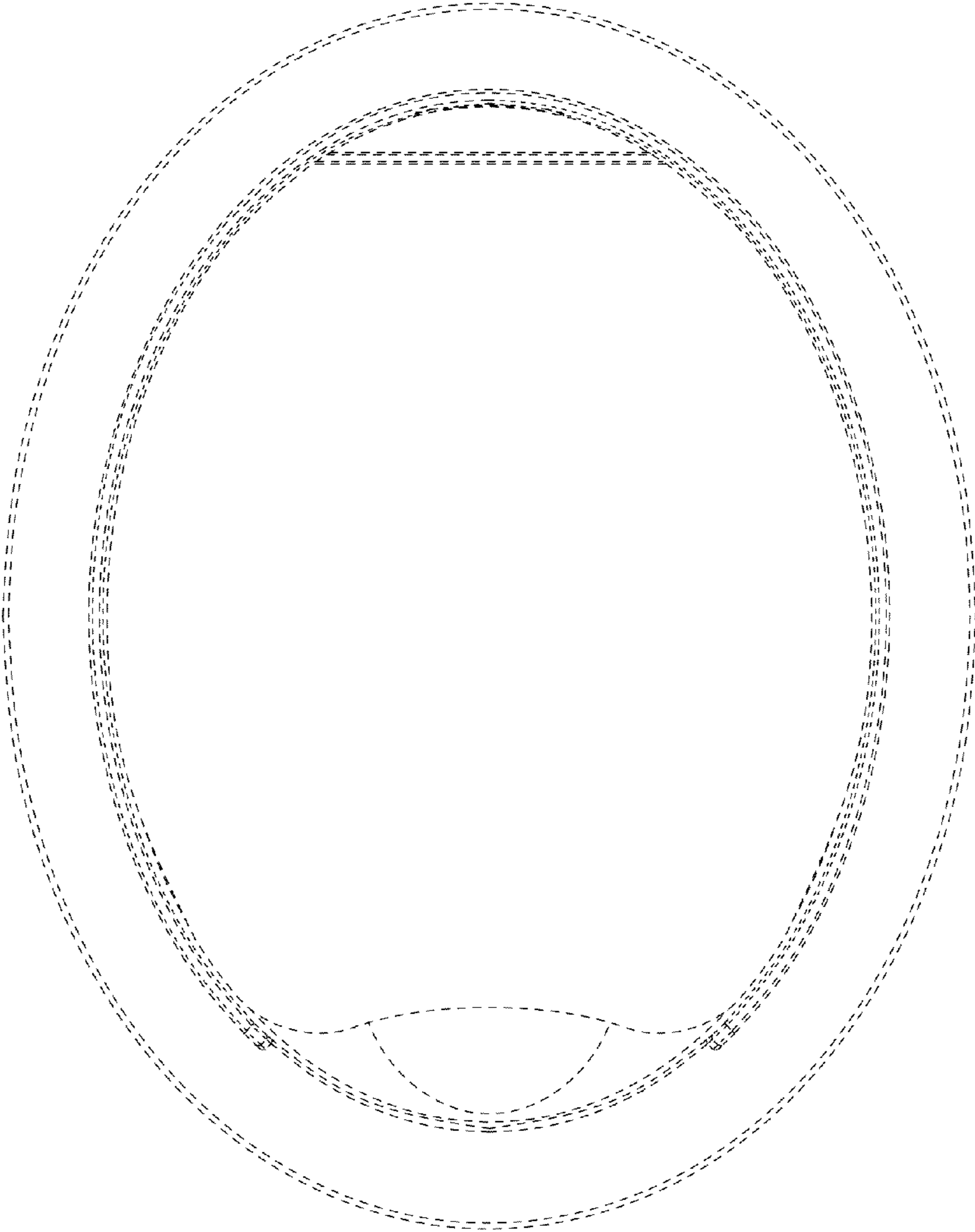

Fig. 5

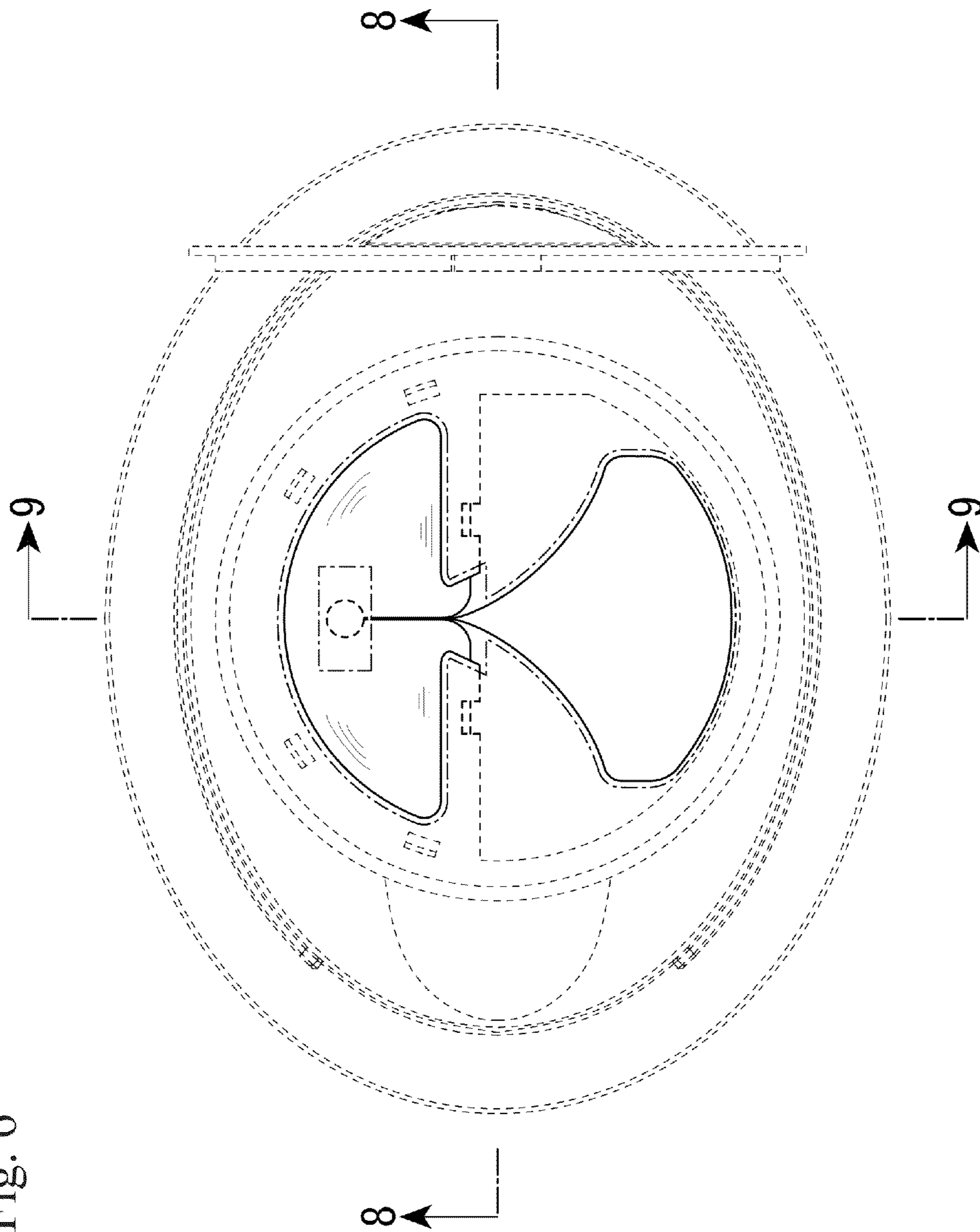

Fig. 6

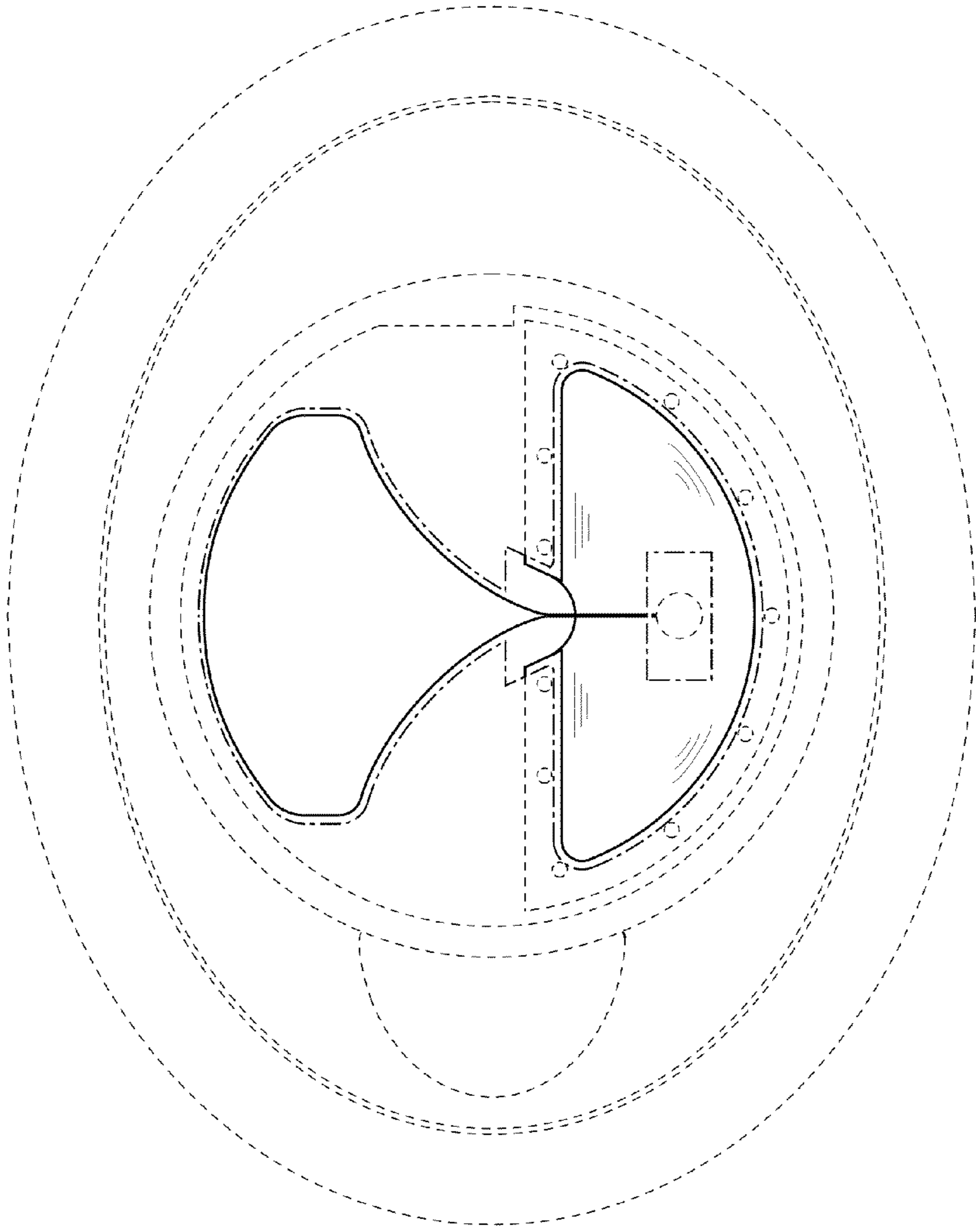

Fig. 7

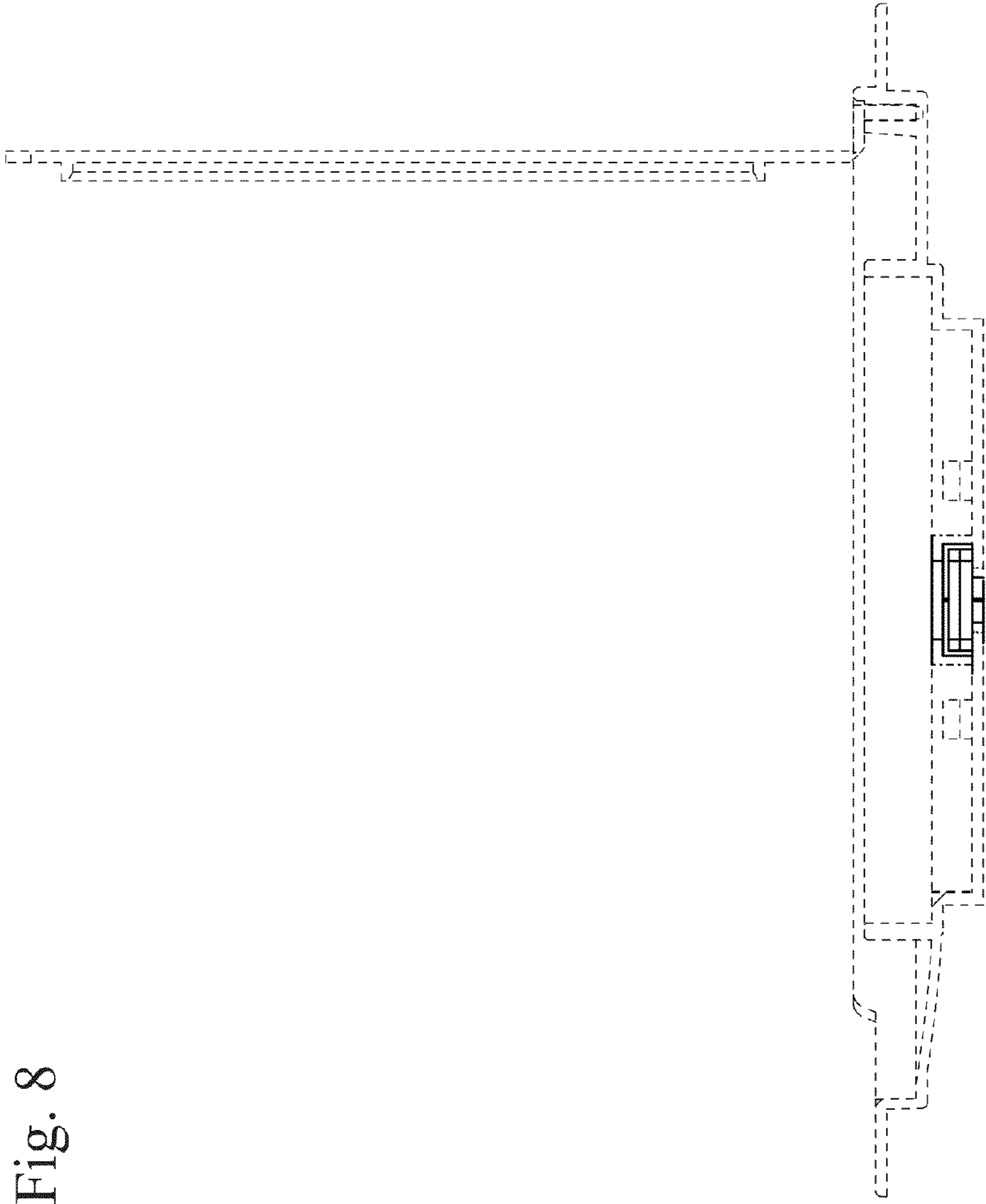

Fig. 8

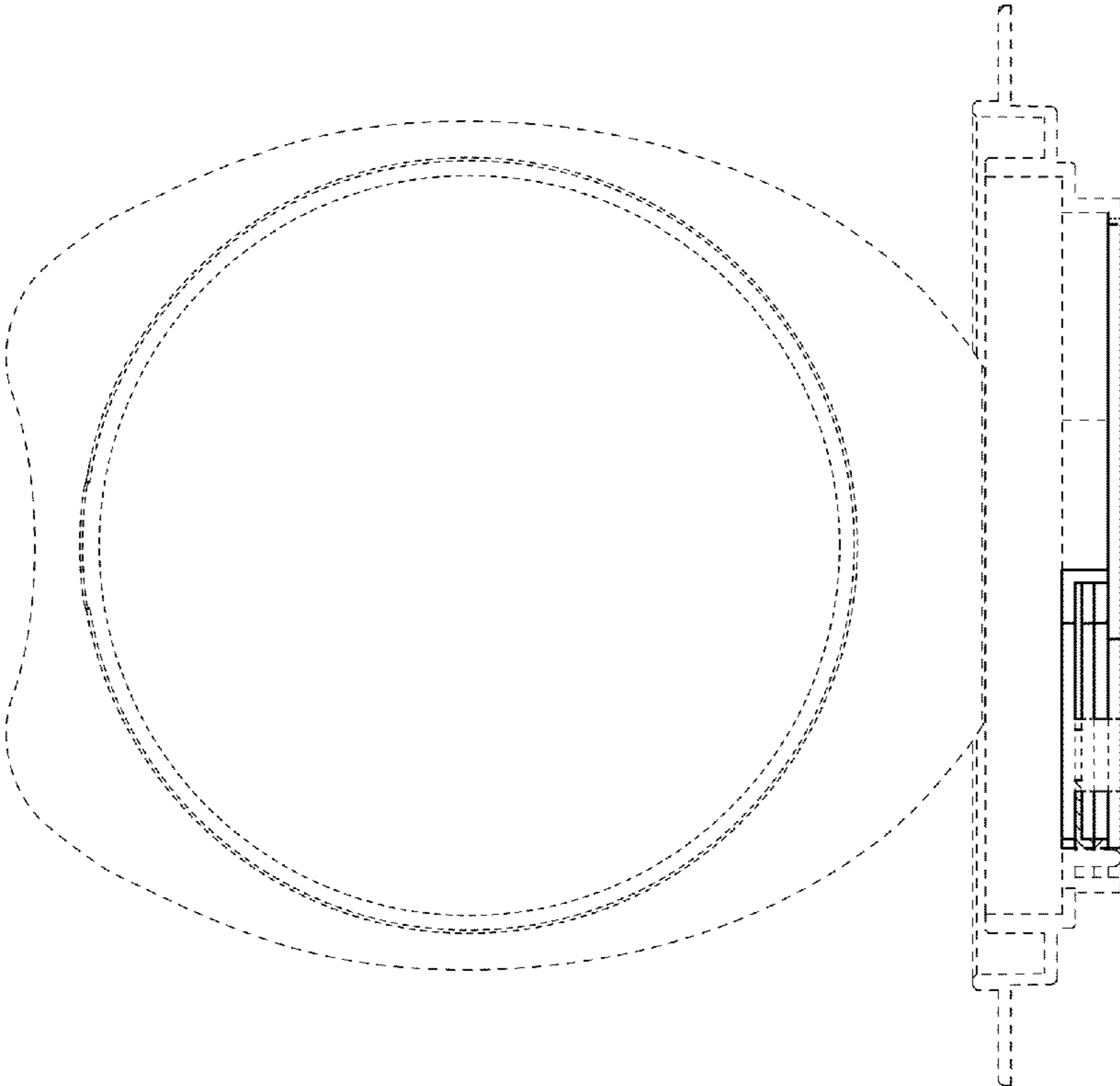

Fig. 9

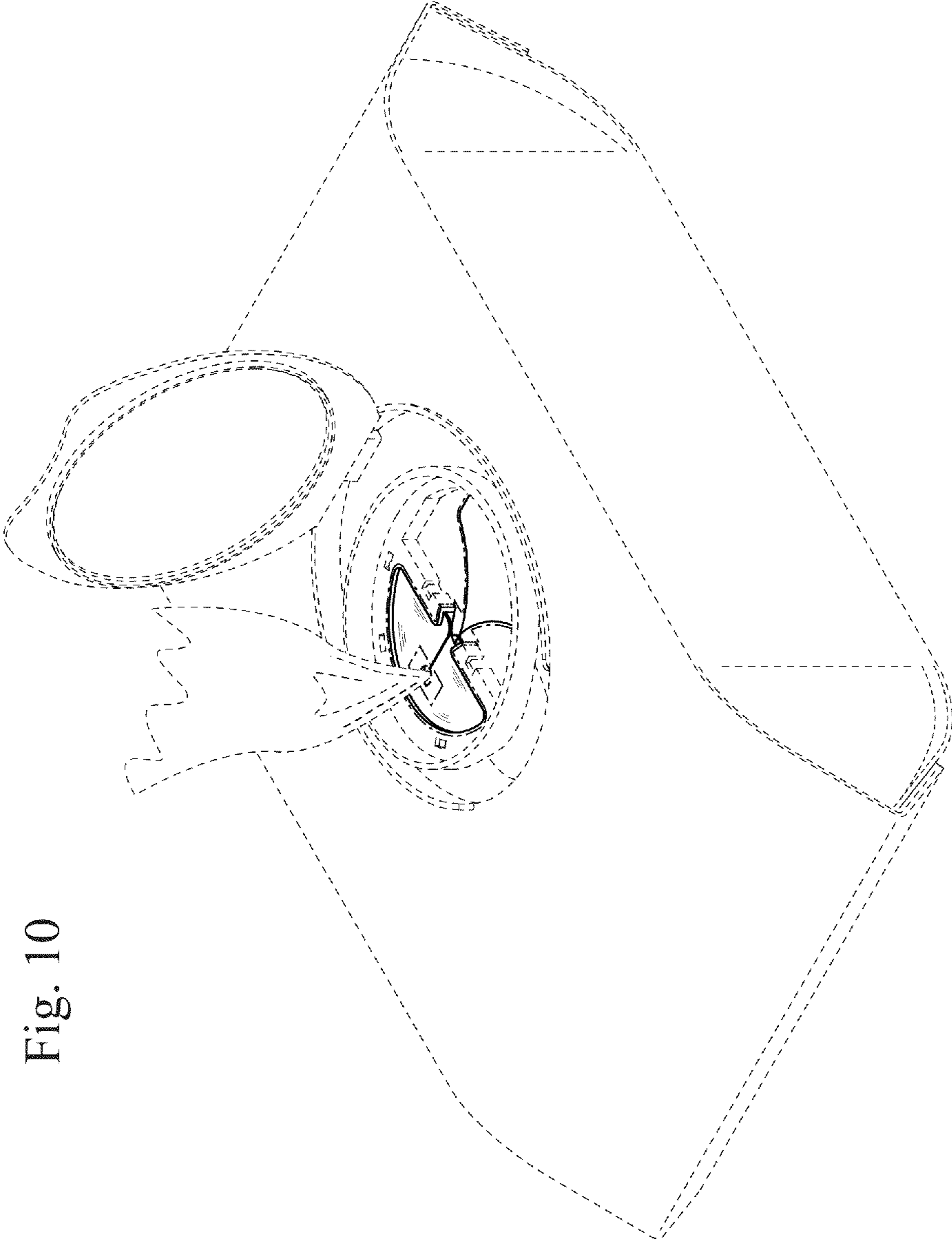

Fig. 10