



US00D703471S

(12) **United States Design Patent**
Battilana

(10) **Patent No.:** **US D703,471 S**
(45) **Date of Patent:** **** Apr. 29, 2014**

(54) **DISPLAY FIXTURE FOR HIGHLIGHTING PRODUCTS**

FOREIGN PATENT DOCUMENTS

(71) Applicant: **S.C. Johnson**, Racine, WI (US)

CN 2513183 Y 9/2002
EP 1145672 A1 10/2001
JP 04510200 B2 7/2010

(72) Inventor: **Pablo Javier Battilana**, Buenos Aires (AR)

OTHER PUBLICATIONS

“Value Proposition”, Proven Science Meets Retail Art (2012).

(73) Assignee: **S.C. Johnson & Sons, Inc.**, Racine, WI (US)

(Continued)

(**) Term: **14 Years**

Primary Examiner — Cathron Brooks
Assistant Examiner — Sydney R Buffalow

(21) Appl. No.: **29/433,561**

(57) **CLAIM**

The ornamental design for a display fixture for highlighting products, as shown and described.

(22) Filed: **Oct. 1, 2012**

DESCRIPTION

(51) **LOC (10) Cl.** **06-04**

(52) **U.S. Cl.**

USPC **D6/702**

(58) **Field of Classification Search**

USPC D6/683.1, 672, 675.1, 560, 662.1,
D6/691.1, 691.8, 675.3, 355, 349, 657,
D6/702, 682.2, 675; 211/186, 189, 59.4,
211/59.3, 187, 10

See application file for complete search history.

FIG. 1 is a perspective view of a display fixture for highlighting products in accordance with the present disclosure.

FIG. 2 is an enlarged perspective view of a corner of a display fixture for highlighting products in accordance with the present disclosure.

FIG. 3 is a front elevational view of a corner of a display fixture for highlighting products in accordance with the present disclosure.

FIG. 4 is a rear elevational view of a corner of a display fixture for highlighting products in accordance with the present disclosure.

FIG. 5 is a top plan view of a corner of a display fixture for highlighting products in accordance with the present disclosure; and,

FIG. 6 is a side elevational view of a corner of a display fixture for highlighting products in accordance with the present disclosure.

The broken lines shown as dash-dot-dot lines are for the purposes of illustrating the environment in which the article resides and form no part of the claimed design. The broken away symbols shown as dashed lines in the drawings indicate the appearance of any portion of the article between the break lines forms no part of the claimed design.

(56) **References Cited**

U.S. PATENT DOCUMENTS

1,336,831 A	4/1920	Finch	
D129,825 S *	10/1941	Simon	D6/478
D230,672 S *	3/1974	Strasser	D6/449
D244,077 S *	4/1977	Saltz	D6/479
D250,623 S *	12/1978	Albert	D6/560
D253,567 S *	12/1979	Ungaro	D6/479
D253,741 S *	12/1979	Ungaro	D6/479
D256,307 S *	8/1980	Frank	D6/436
D267,992 S *	2/1983	Shelton	D6/470
4,423,913 A	1/1984	Lee	

(Continued)

1 Claim, 5 Drawing Sheets

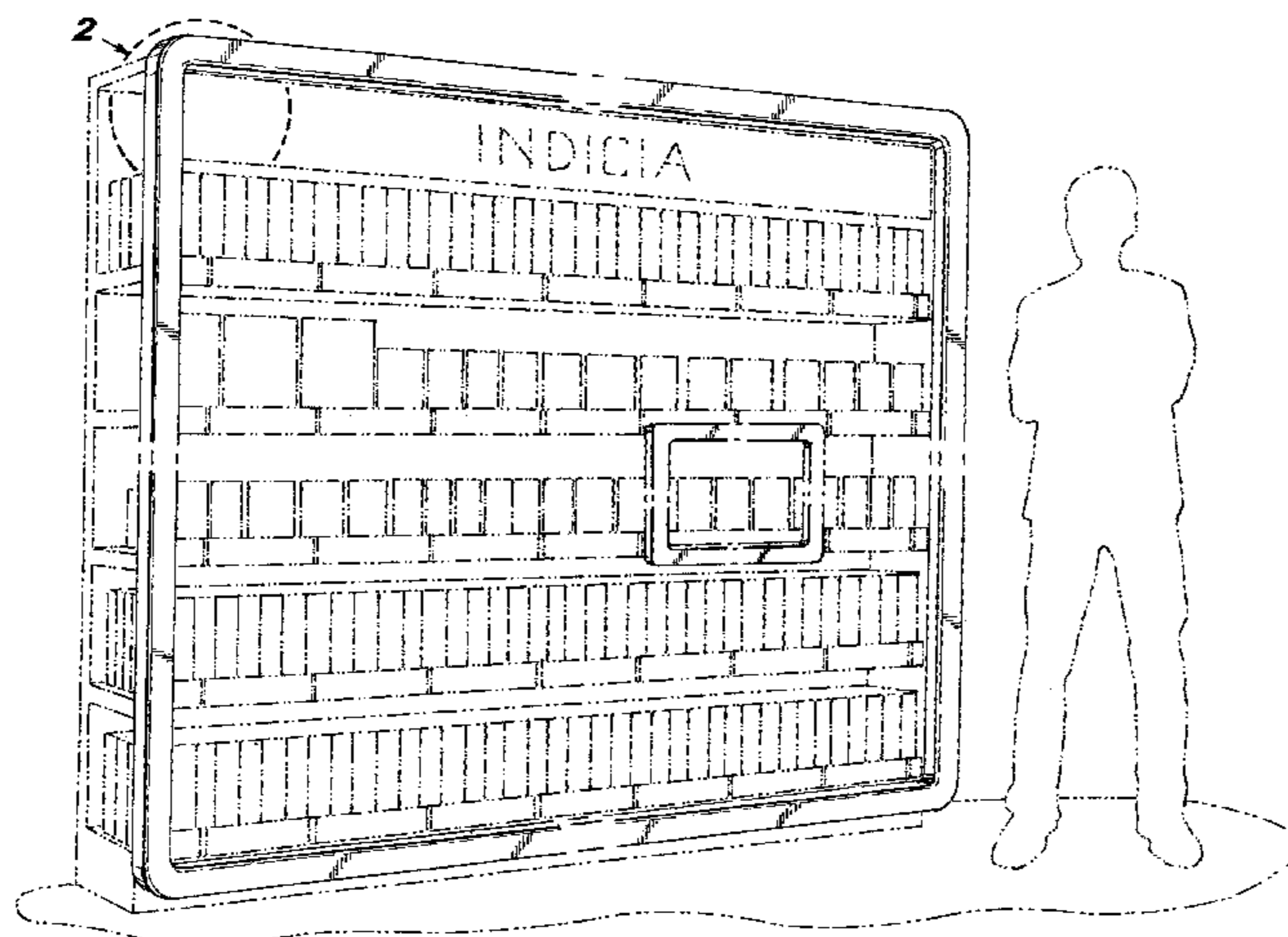

(56)

References Cited

U.S. PATENT DOCUMENTS

D274,676 S * 7/1984 Massonnet D6/349
 D294,787 S * 3/1988 Berry, Jr. D6/474
 5,109,994 A 5/1992 Kidd et al.
 5,350,057 A 9/1994 Bemis et al.
 5,412,887 A 5/1995 Layne
 5,464,105 A 11/1995 Mandeltort
 5,909,932 A 6/1999 Shih
 6,193,085 B1 2/2001 Nook et al.
 D448,208 S * 9/2001 Alden D6/462
 6,497,329 B1 12/2002 Johnson et al.
 6,644,484 B1 11/2003 Sardis
 D517,352 S * 3/2006 Wicha D6/479
 7,150,365 B2 12/2006 Hardy et al.
 D548,484 S * 8/2007 Kieffer D6/436
 D602,271 S * 10/2009 Schwartz et al. D6/355
 7,757,418 B1 7/2010 Clark et al.
 7,810,658 B2 10/2010 Clark et al.
 7,900,784 B1 3/2011 Weigand et al.

7,988,000 B2 8/2011 Clark et al.
 7,997,430 B2 8/2011 Clark et al.
 D644,446 S * 9/2011 Schwartz et al. D6/349
 8,123,052 B2 * 2/2012 Clark et al. 211/186
 8,152,006 B2 4/2012 Wamsley et al.
 8,256,628 B2 9/2012 Stafford et al.
 2002/0134741 A1 * 9/2002 LaFontaine et al. 211/10
 2004/0035814 A1 * 2/2004 Martins 211/187
 2004/0251226 A1 * 12/2004 Yang 211/187
 2007/0022644 A1 2/2007 Lynch et al.
 2009/0039040 A1 2/2009 Johnson et al.
 2009/0166304 A1 * 7/2009 Hardy et al. 211/59.3
 2009/0230070 A1 * 9/2009 Anderson et al. 211/186
 2010/0044326 A1 2/2010 Meyer-Hanover et al.
 2010/0320164 A1 12/2010 Clark et al.

OTHER PUBLICATIONS

H. Sorensen, Ph.D. et al., "Mid-Caps: Break Out of the Pack", TNS Retail & Shopper (May 11, 2009).

* cited by examiner

Fig. 1

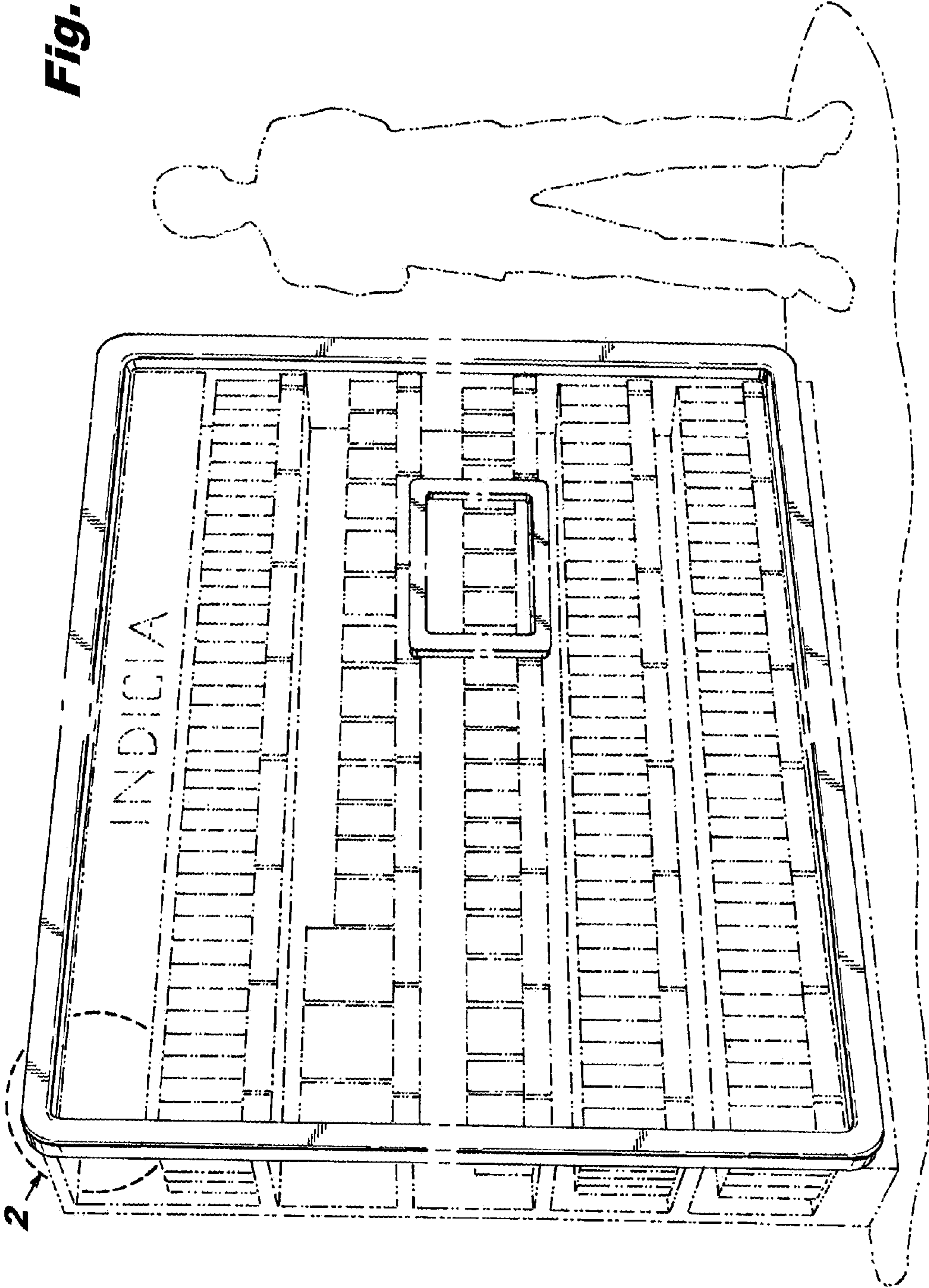

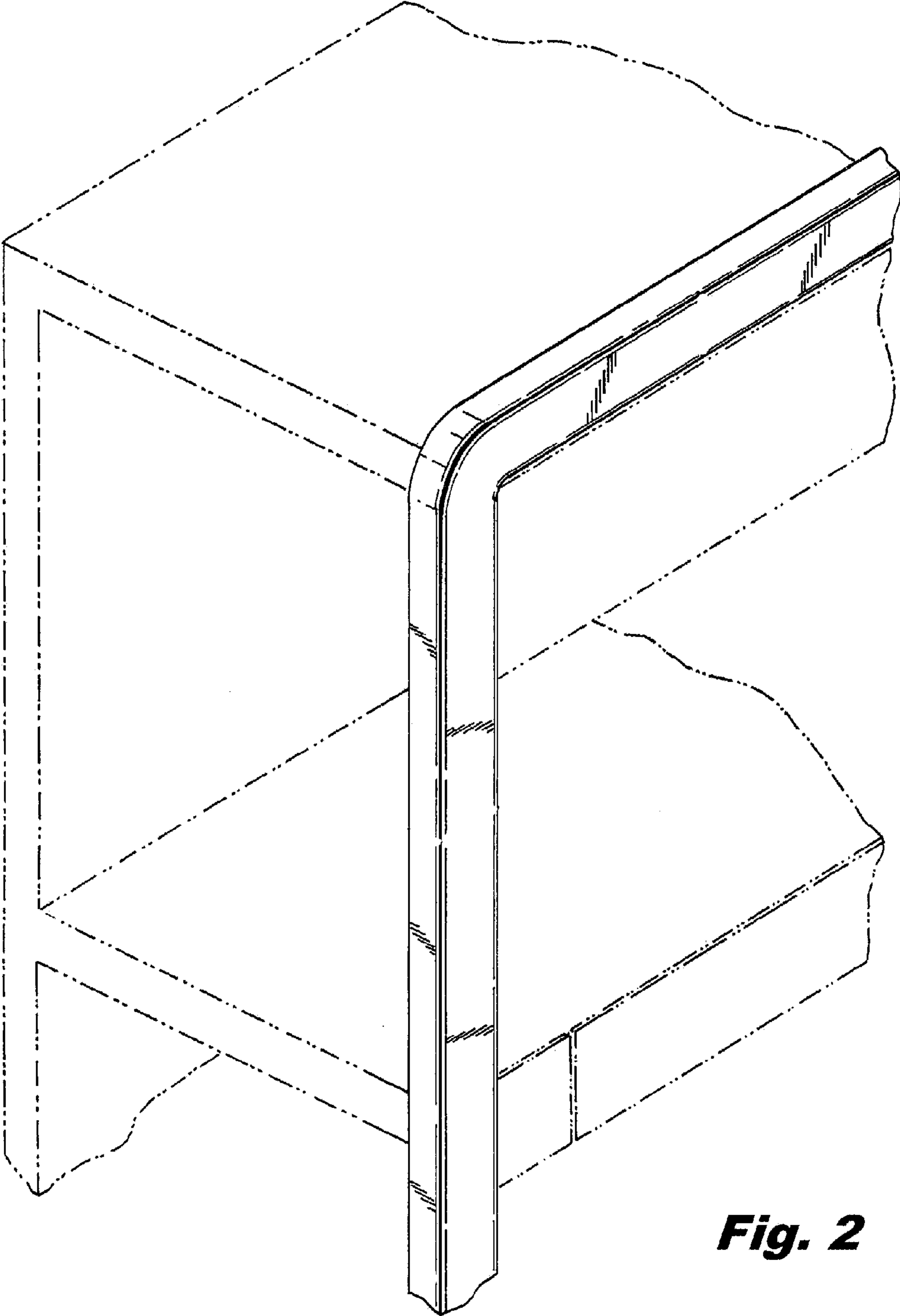

Fig. 2

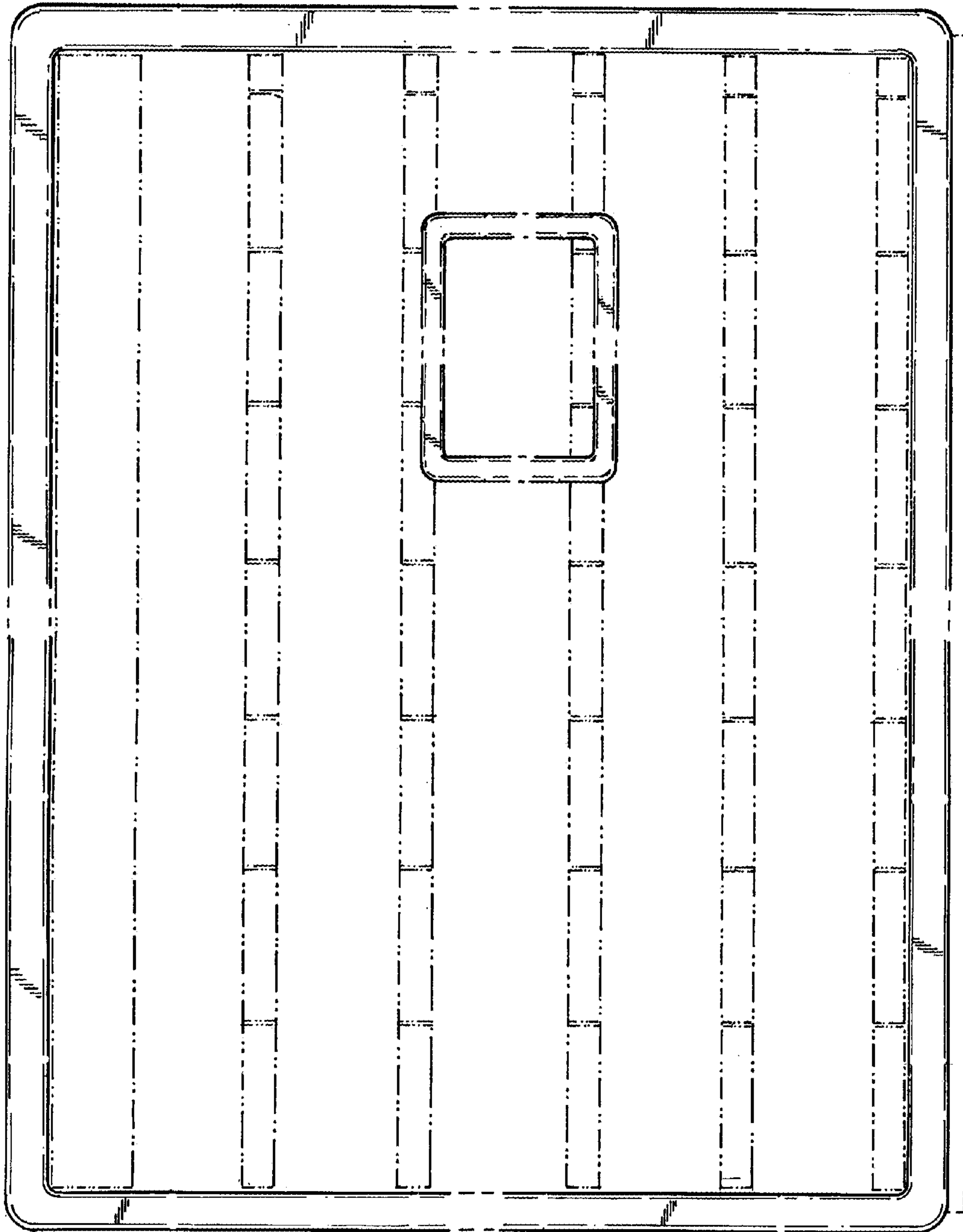
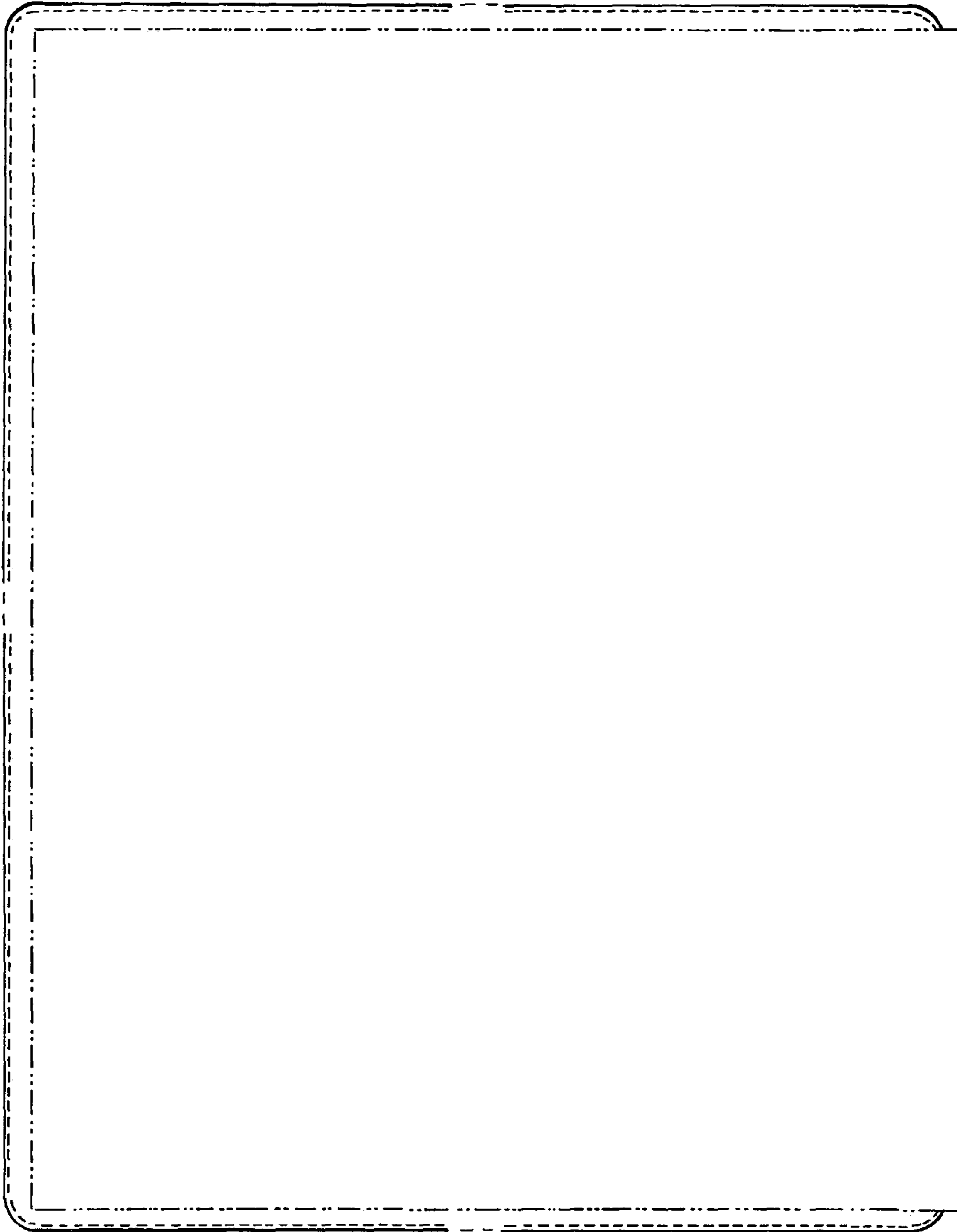

Fig. 3

Fig. 4



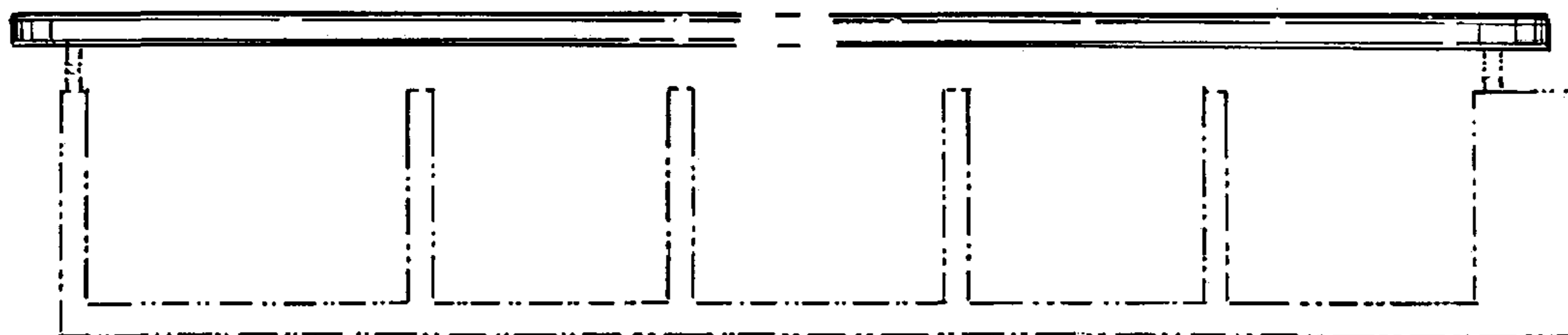

Fig. 6



Fig. 5