



US00D703207S

(12) **United States Design Patent**  
**Ahn et al.**

(10) **Patent No.:** **US D703,207 S**  
(45) **Date of Patent:** **\*\* Apr. 22, 2014**

(54) **AUTOMOTIVE DOCKING STATION**

D682,840 S \* 5/2013 Tsai et al. .... D14/447

(71) Applicant: **Google Inc.**, Mountain View, CA (US)

\* cited by examiner

(72) Inventors: **YooJung Ahn**, Cupertino, CA (US);  
**Peter Craig Lombrozo**, Santa Cruz, CA (US)

*Primary Examiner* — Freda S Nunn

(74) *Attorney, Agent, or Firm* — Lerner, David, Littenberg, Krumholz & Mentlik, LLP

(73) Assignee: **Google Inc.**, Mountain View, CA (US)

(57) **CLAIM**

The ornamental design for an automotive docking station, as shown and described.

(\*\*) Term: **14 Years**

**DESCRIPTION**

(21) Appl. No.: **29/438,507**

(22) Filed: **Nov. 30, 2012**

(51) **LOC (10) Cl.** ..... **14-02**

(52) **U.S. Cl.**  
USPC ..... **D14/434; D12/400**

(58) **Field of Classification Search**  
USPC ..... D14/432–434, 314, 204, 420, 421, 447,  
D14/217, 358, 138 R, 140, 142; D13/107,  
D13/108, 146; D8/373; 248/346.03, 176.1;  
361/679.41, 679.31, 679.32, 679.4,  
361/679.43, 679.55, 679.58, 679.33;  
320/109, 112–115; 710/15, 303;  
455/557; 439/347, 534; D6/512, 574;  
D12/400, 415

See application file for complete search history.

FIG. 1 is a rear perspective view of an automotive docking station according to a first embodiment thereof;  
FIG. 2 is a front elevation view thereof;  
FIG. 3 is a rear elevation view thereof;  
FIG. 4 is a right side elevation view thereof;  
FIG. 5 is a left side elevation view thereof;  
FIG. 6 is a top view thereof;  
FIG. 7 is a bottom view thereof;  
FIG. 8 is a rear perspective view of an automotive docking station according to a second embodiment thereof;  
FIG. 9 is a front elevation view thereof;  
FIG. 10 is a rear elevation view thereof;  
FIG. 11 is a right side elevation view thereof;  
FIG. 12 is a left side elevation view thereof;  
FIG. 13 is a top view thereof;  
FIG. 14 is a bottom view thereof; and,  
FIG. 15 is a rear perspective view thereof shown in connection with additional environmental features that can be associated therewith.

The features shown in broken lines are environmental only and form no part of the claimed design.  
Dash-dot lines adjacent un-shaded areas represent bounds of the claimed design and themselves form no part of the claimed design.

(56) **References Cited**

**U.S. PATENT DOCUMENTS**

D242,313 S *	11/1976	Stentz	.....	D6/574
D398,796 S *	9/1998	Fauchald et al.	.....	D6/512
D477,604 S *	7/2003	Lin	.....	D14/434
D540,327 S *	4/2007	Wong et al.	.....	D14/434
D552,611 S *	10/2007	Hagiwara et al.	.....	D14/434
D599,801 S *	9/2009	Skaf et al.	.....	D14/434
D630,579 S *	1/2011	Fahrendorff et al.	.....	D13/108
D648,339 S *	11/2011	O'Neil et al.	.....	D14/434

**1 Claim, 9 Drawing Sheets**

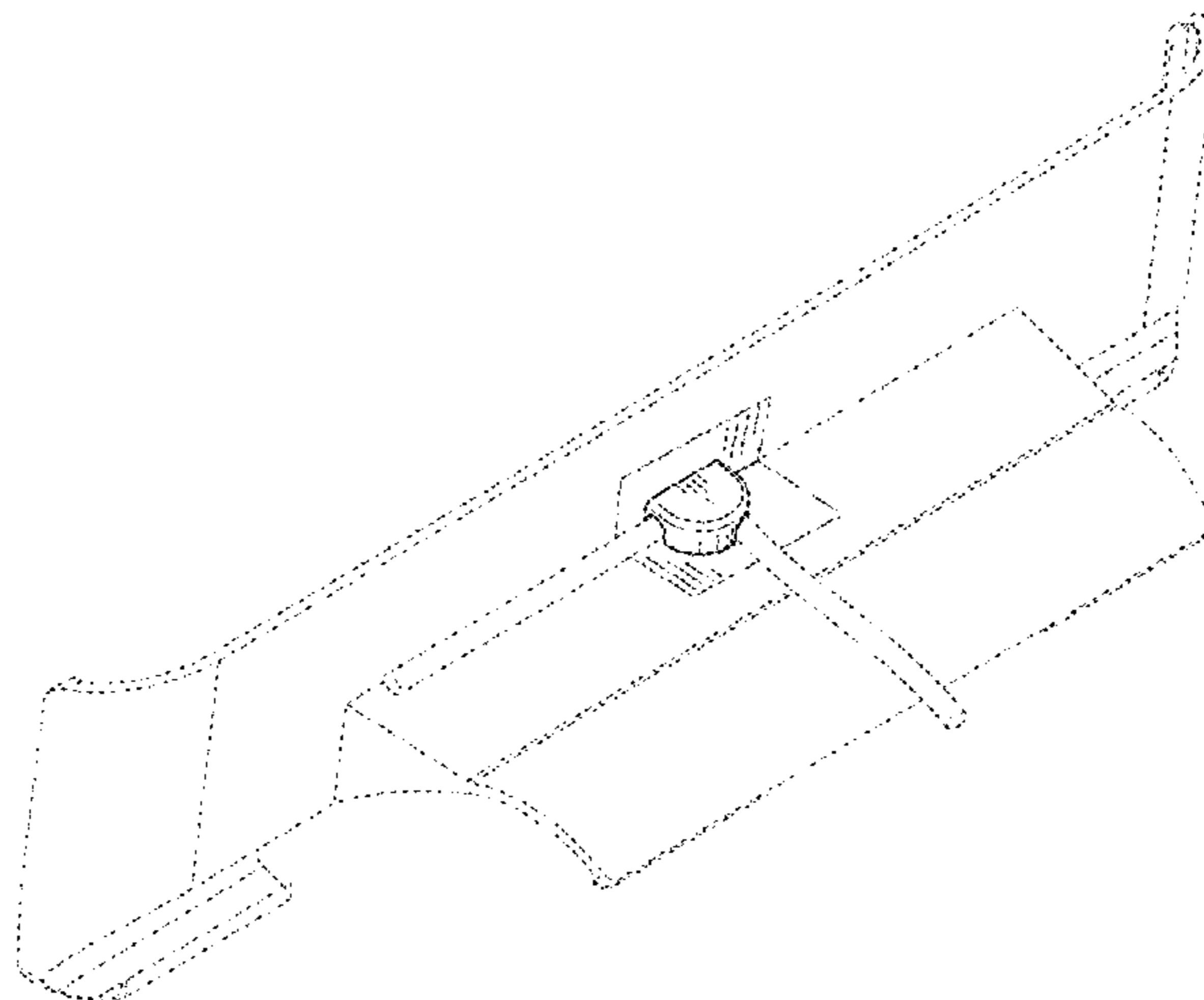

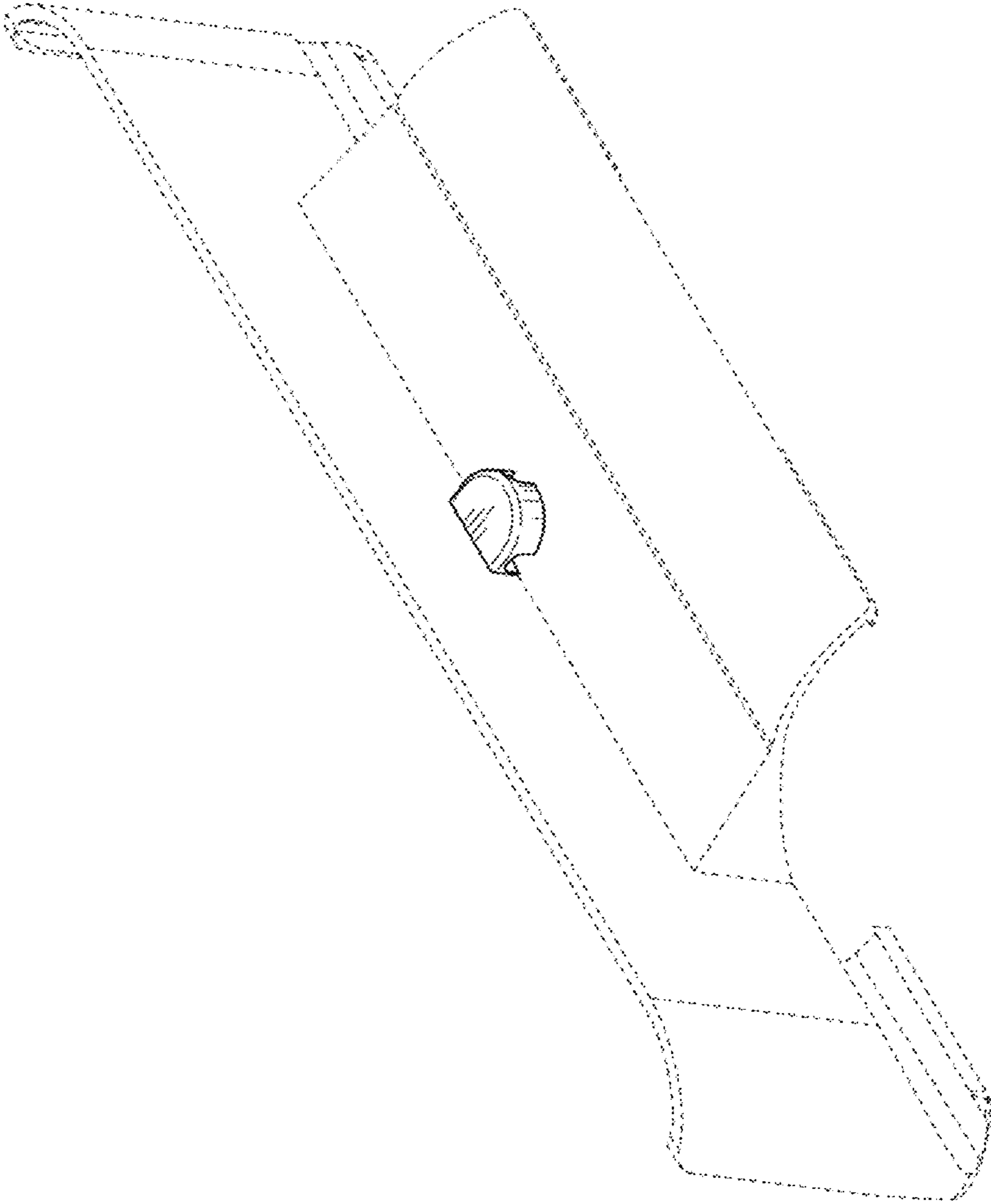

FIG. 1

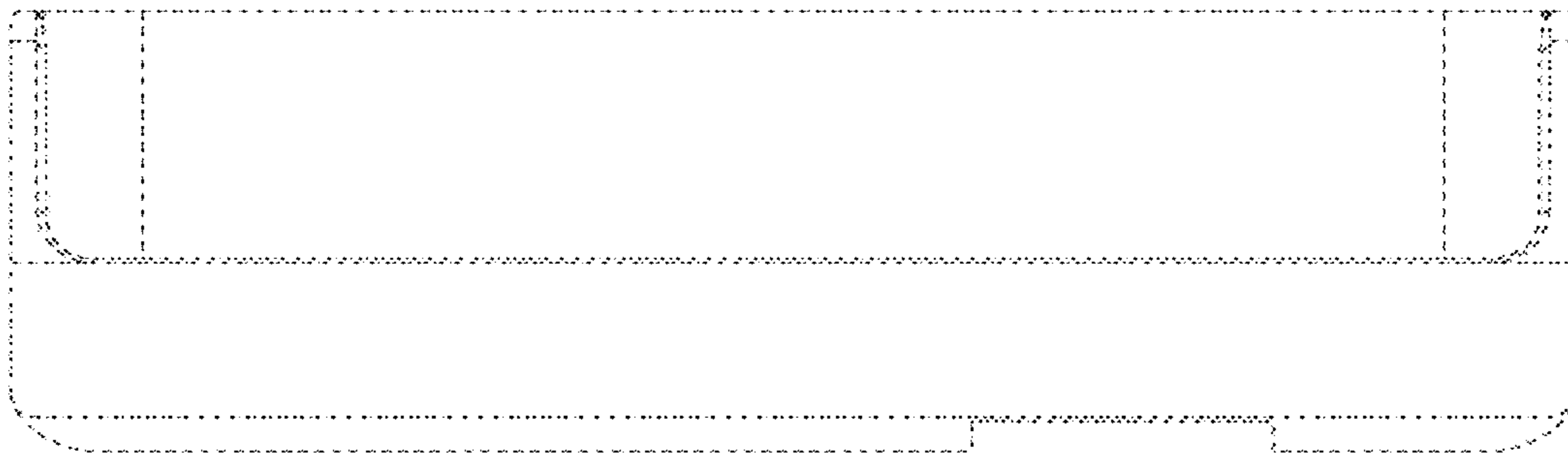

FIG. 2

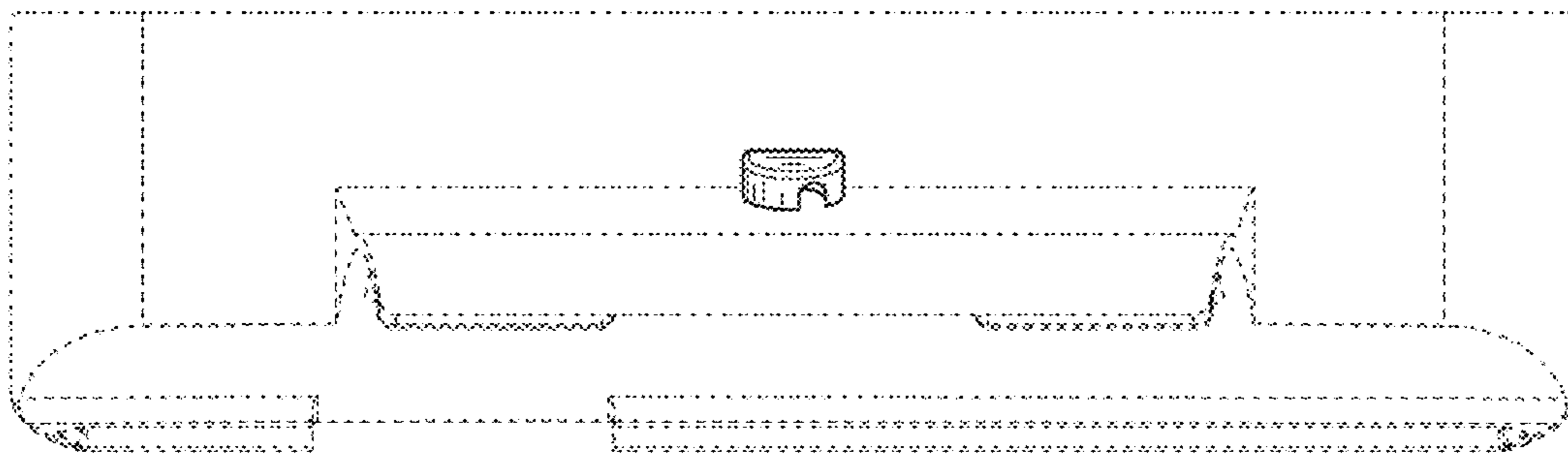

FIG. 3

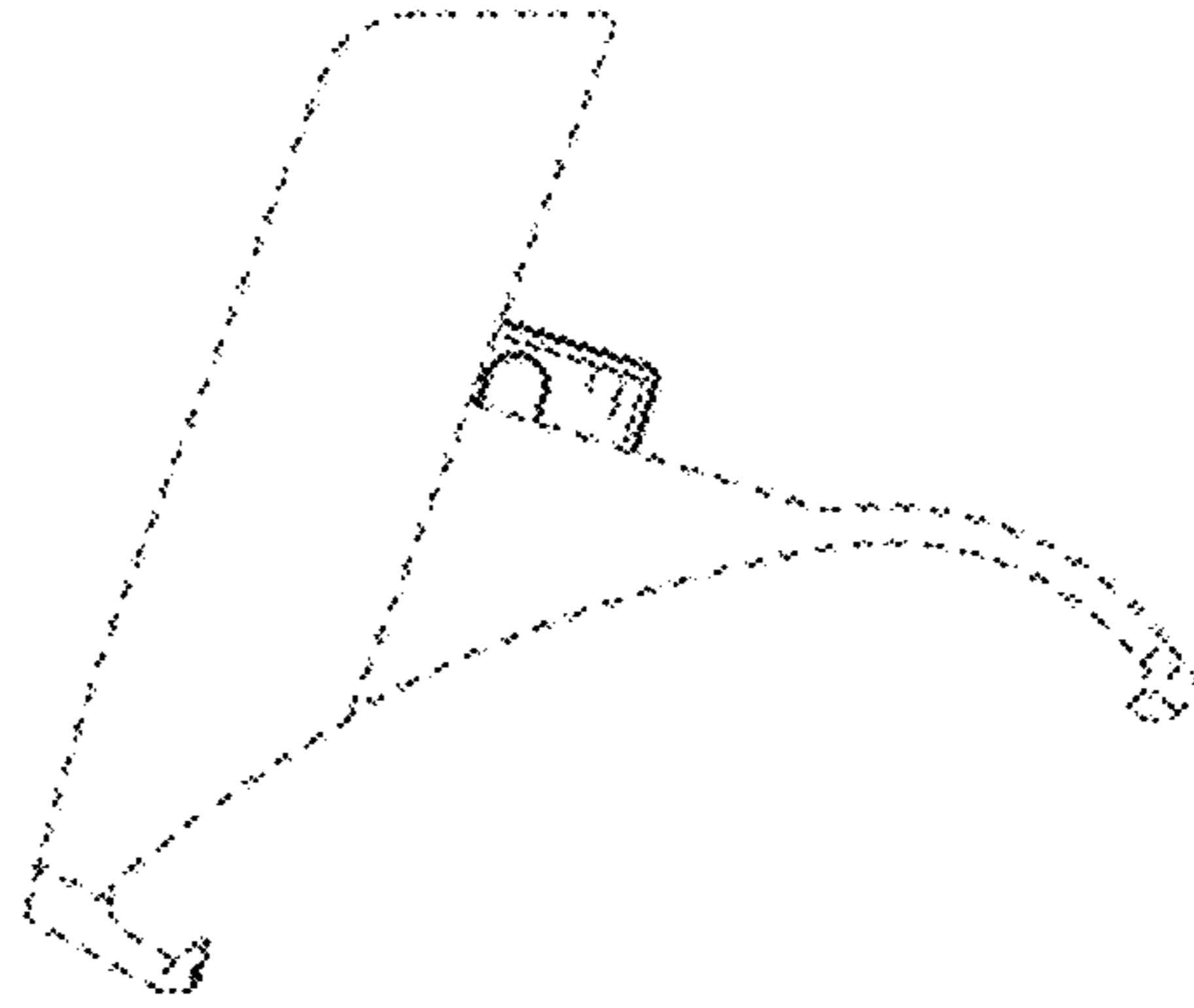

FIG. 4

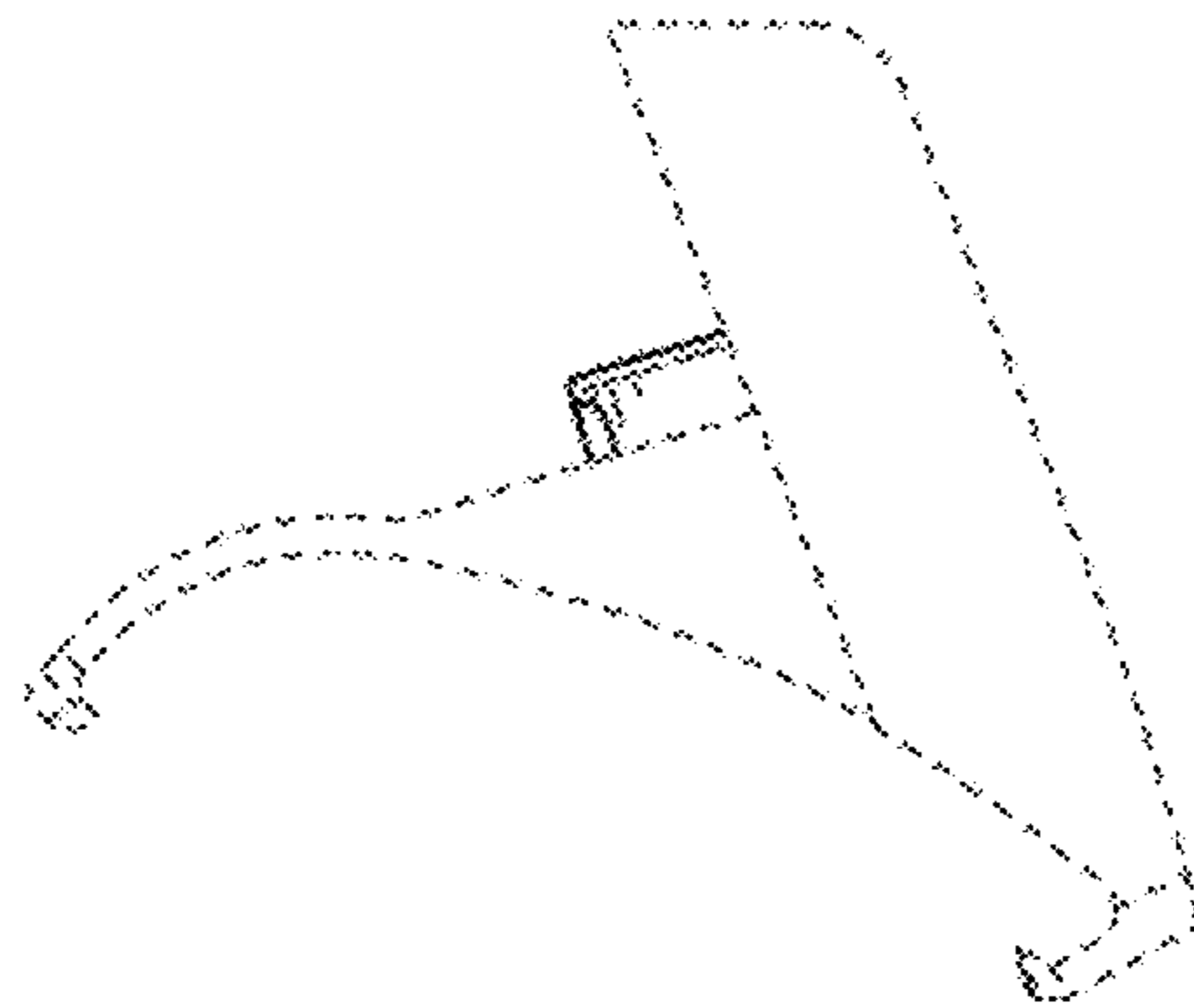

FIG. 5

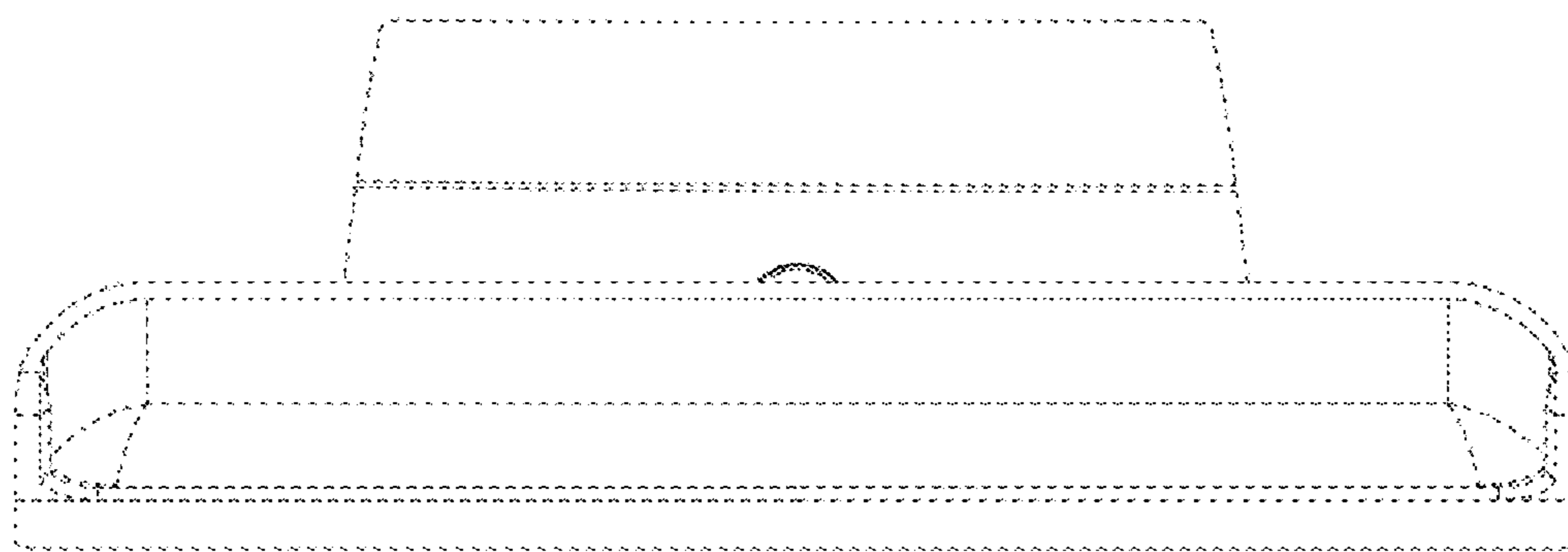

FIG. 6

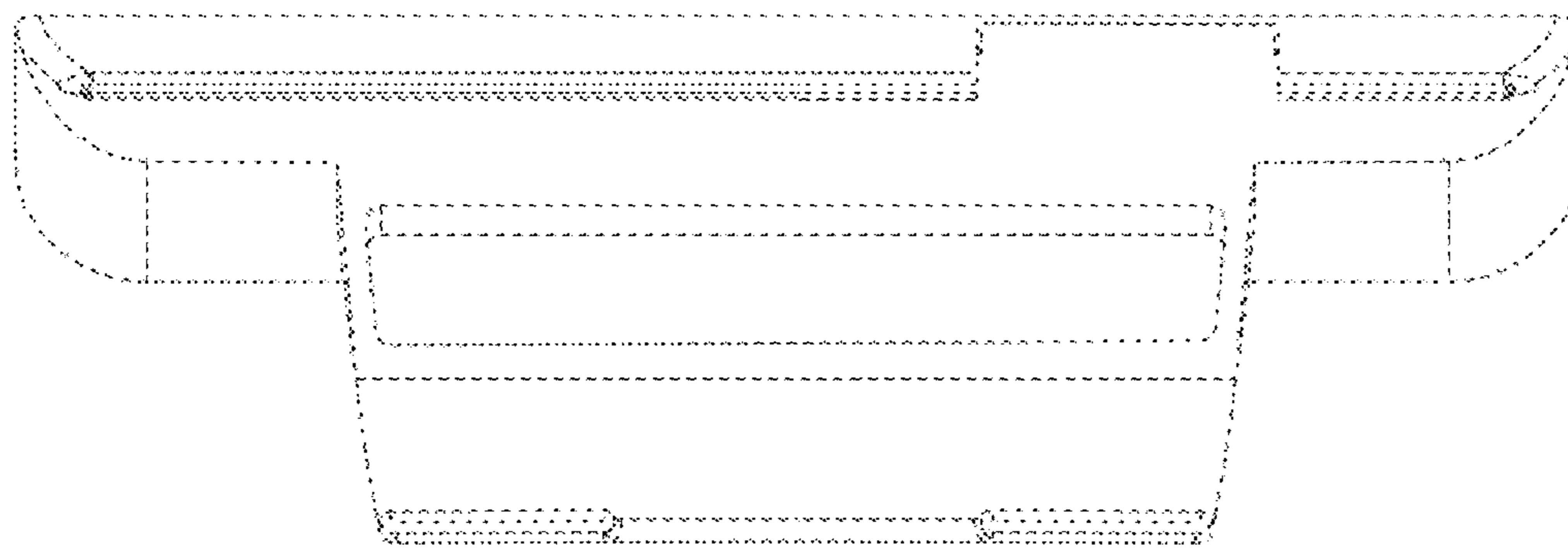

FIG. 7

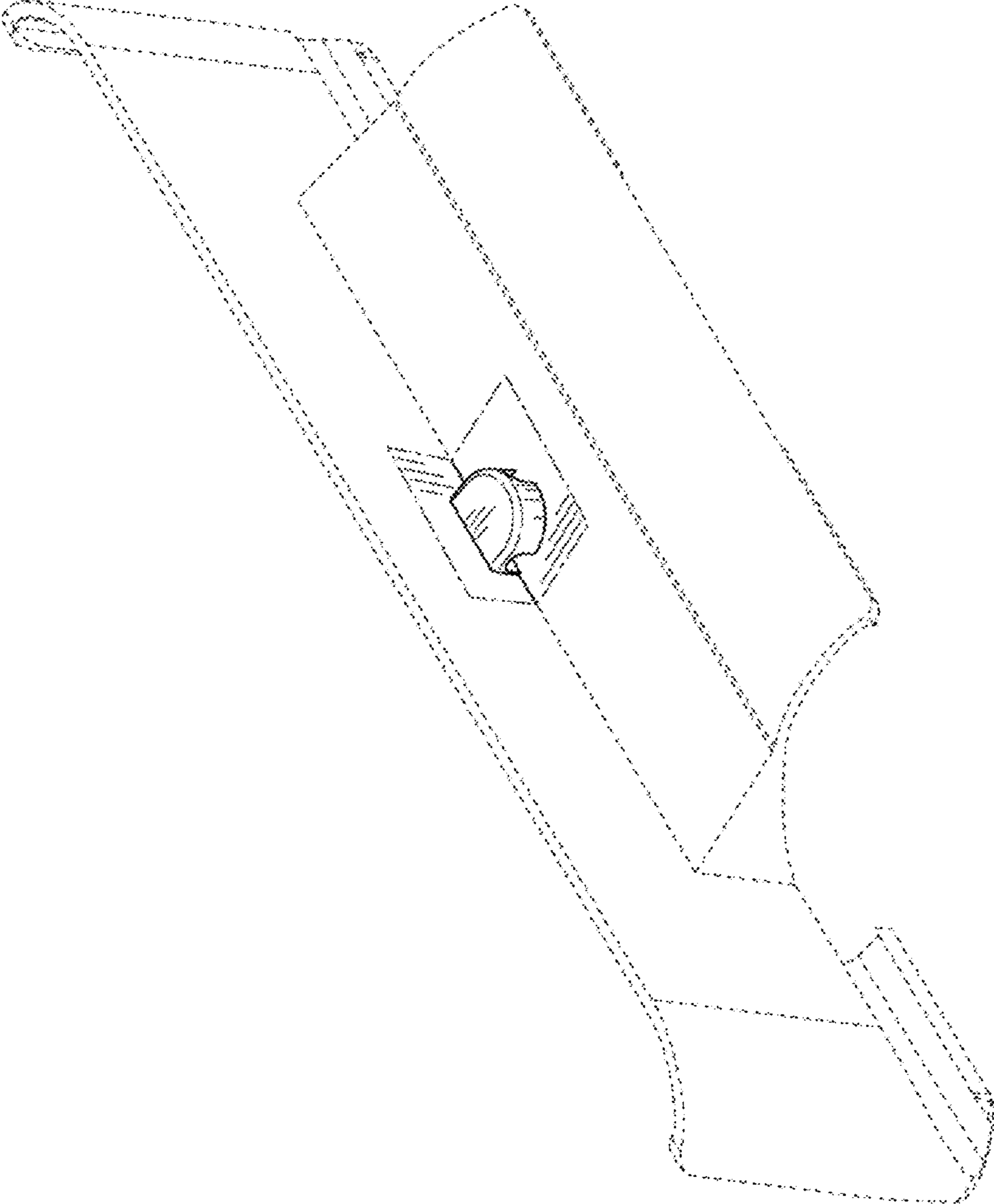

FIG. 8

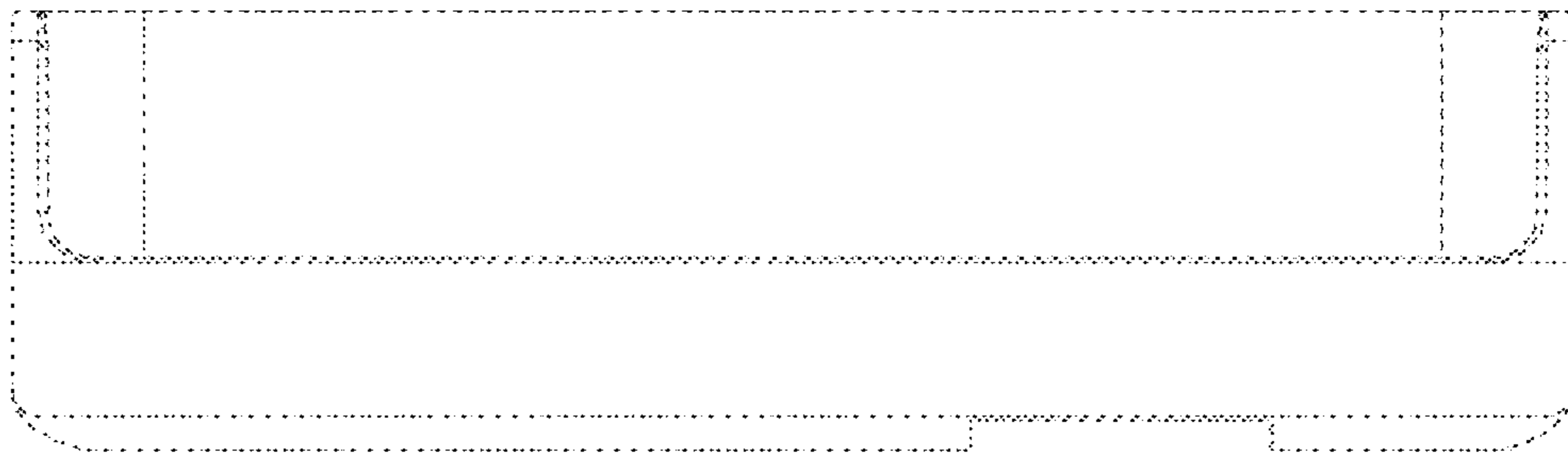

FIG. 9

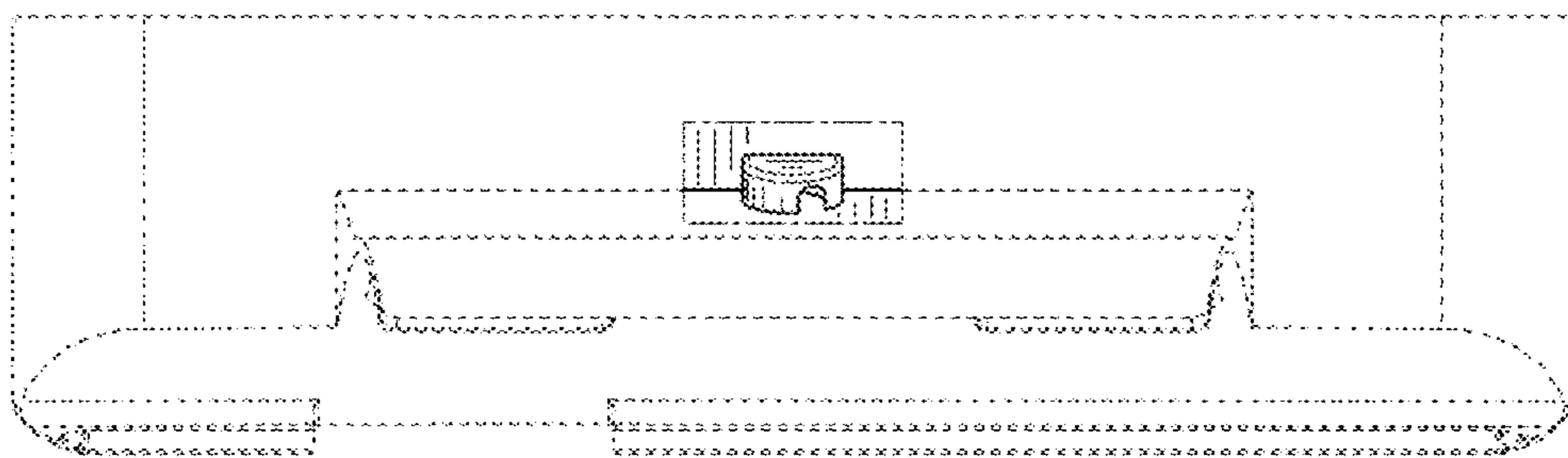

FIG. 10

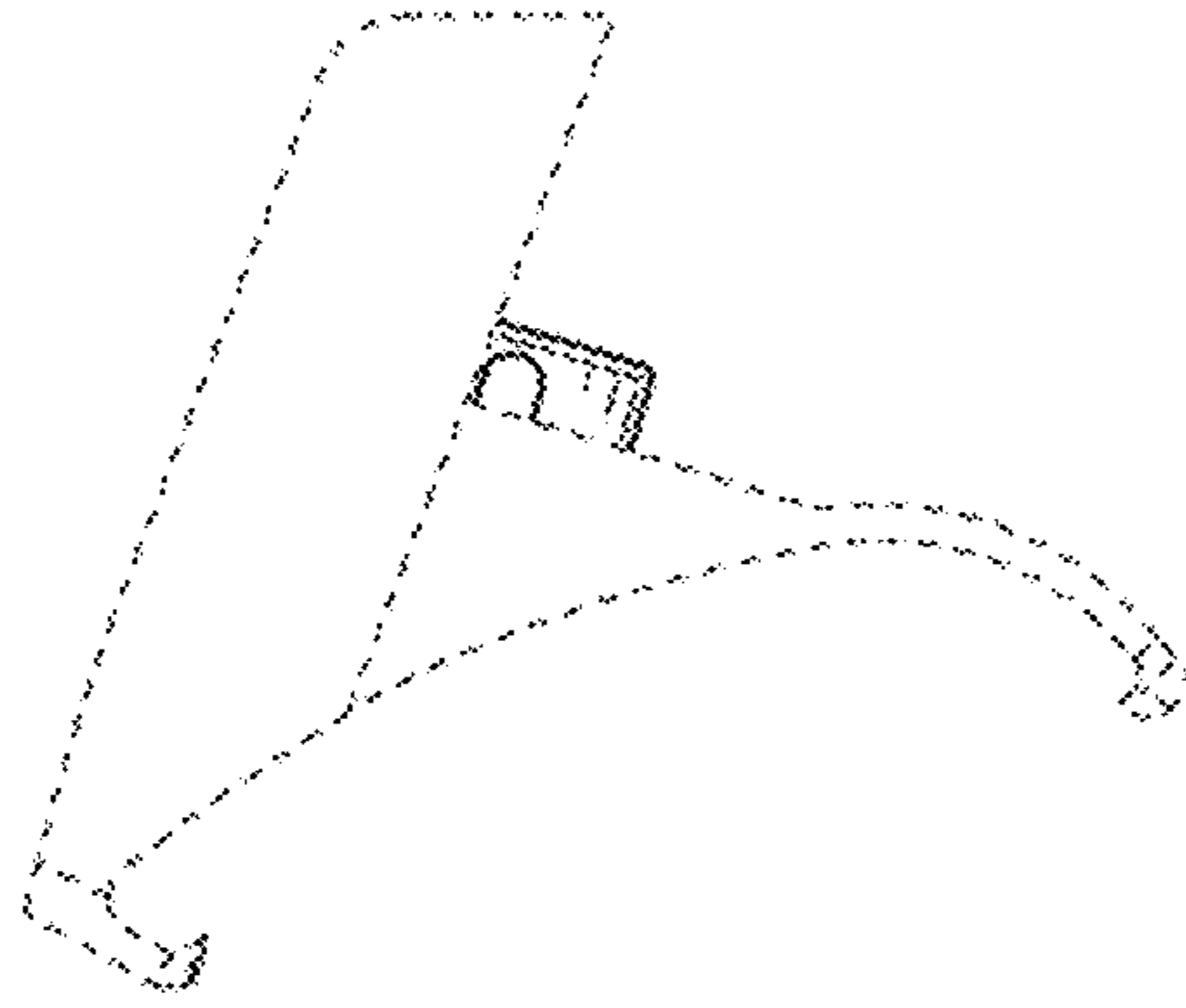

FIG. 11

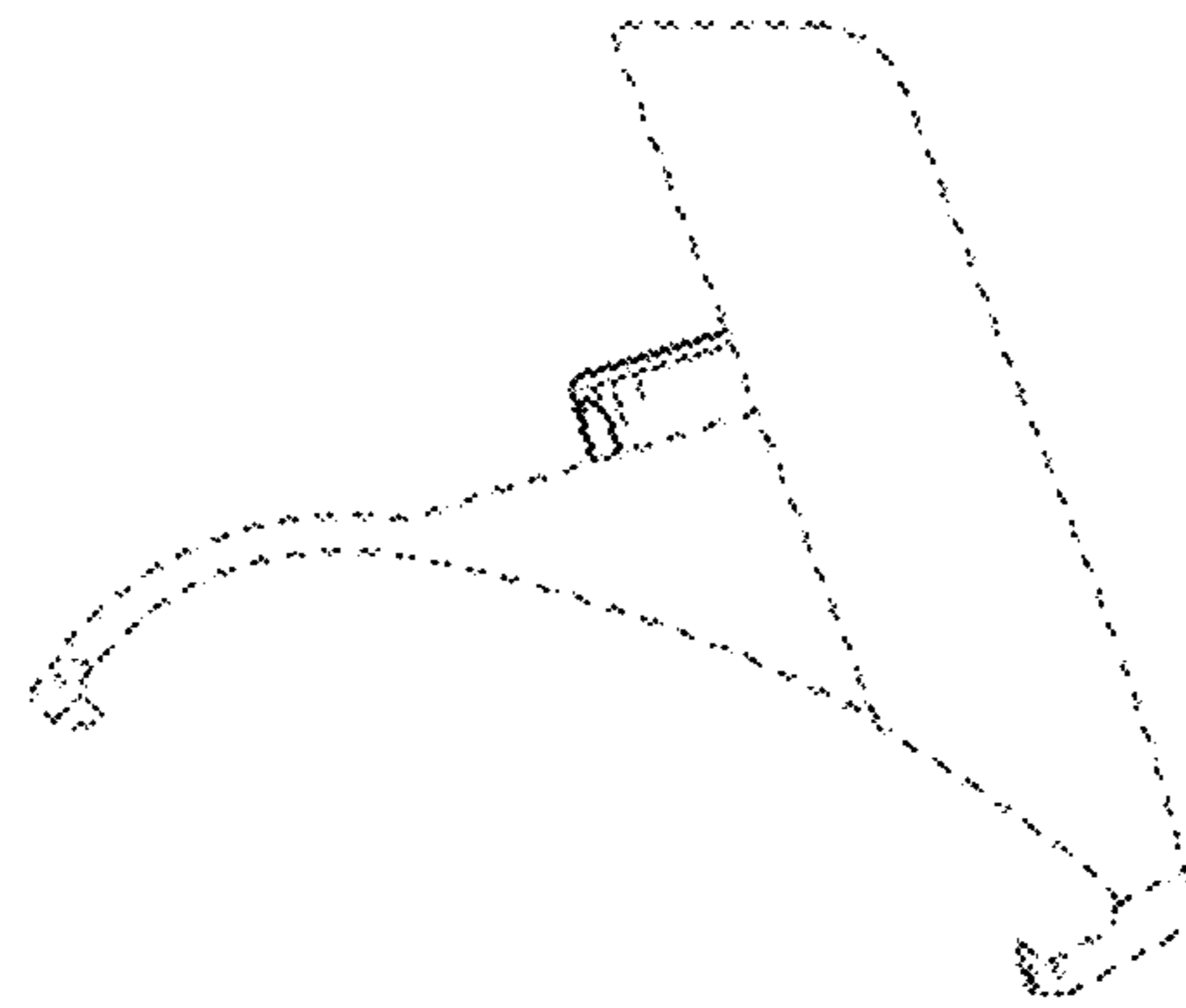

FIG. 12



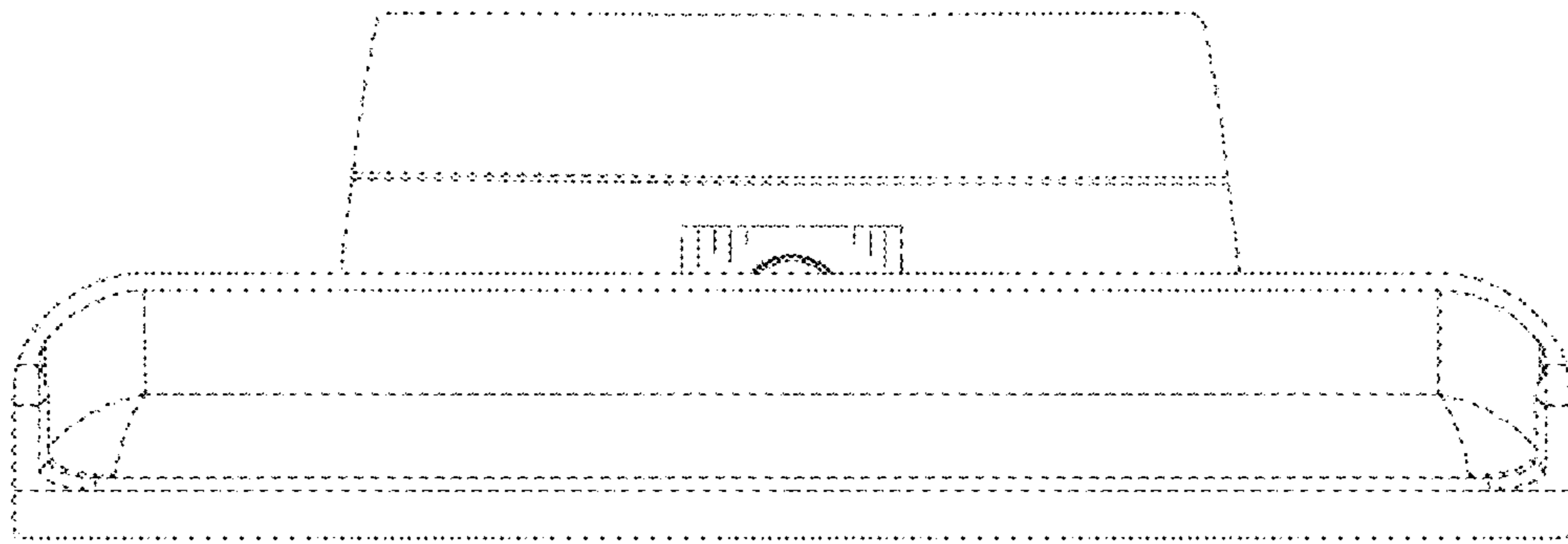

FIG. 13

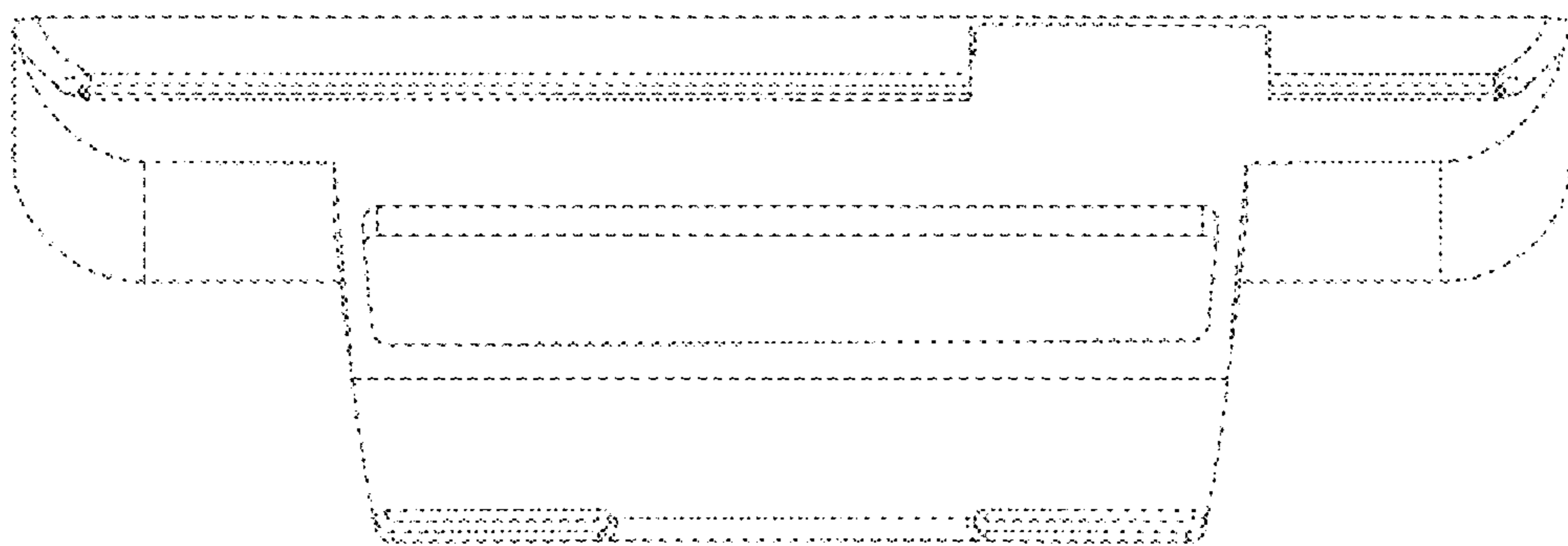

FIG. 14

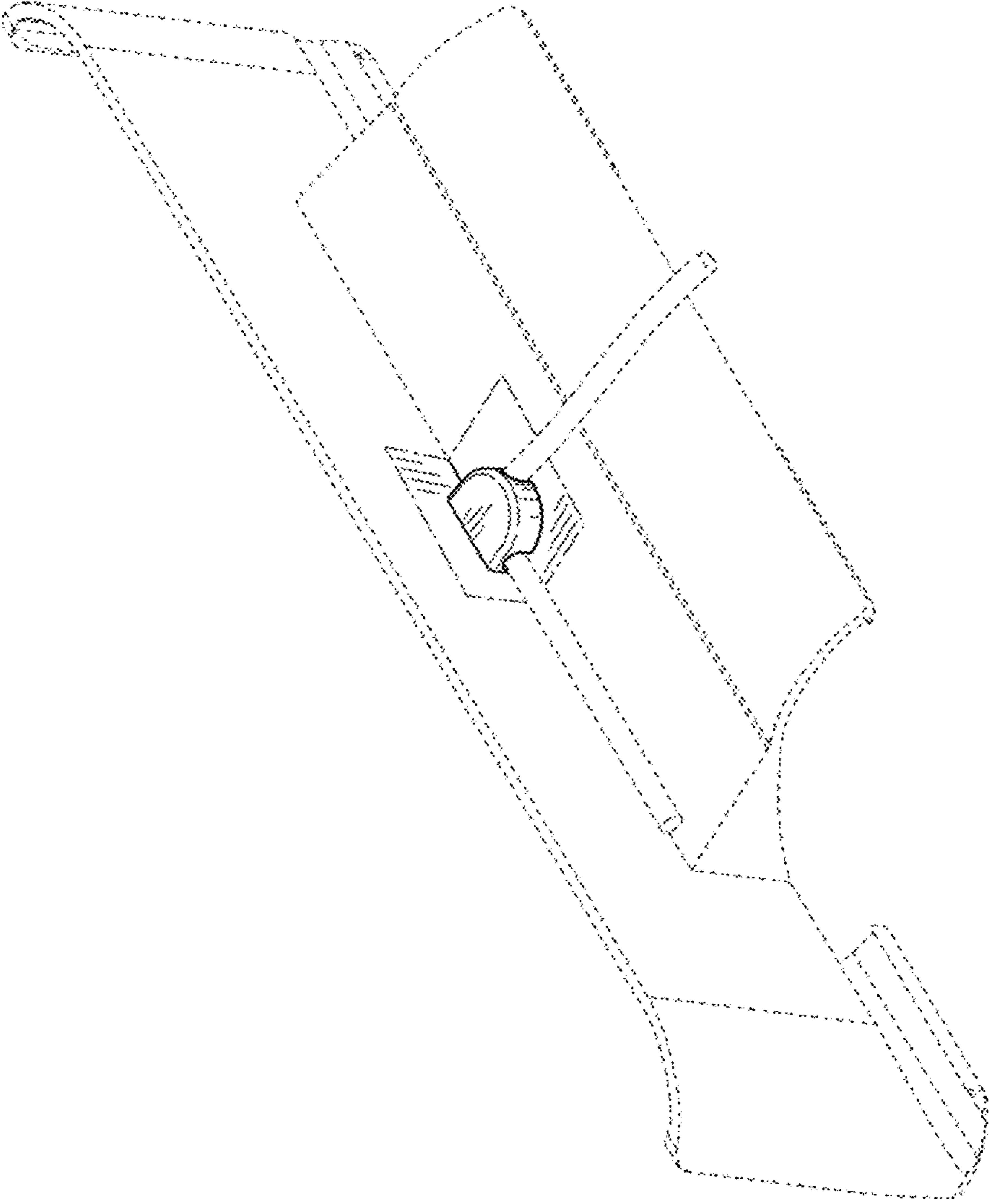

FIG. 15