



US00D703197S

(12) **United States Design Patent**
Melanson et al.

(10) **Patent No.:** **US D703,197 S**
(45) **Date of Patent:** **** Apr. 22, 2014**

(54) **CASE FOR ELECTRONIC DEVICE**

(75) Inventors: **Christopher Melanson**, Fort Collins, CO (US); **Zachariah Pickett**, Fort Collins, CO (US)

(73) Assignee: **Otter Products, LLC**, Fort Collins, CO (US)

(**) Term: **14 Years**

(21) Appl. No.: **29/400,043**

(22) Filed: **Aug. 23, 2011**

(51) **LOC (10) Cl.** **14-03**

(52) **U.S. Cl.**
USPC **D14/250**

(58) **Field of Classification Search**
USPC D14/250–253, 440, 203.3–203.7, 217, D14/496, 248, 238.1, 240, 447, 341–347, D14/444; D13/103, 107–108, 119; D3/201, D3/218, 247, 269, 273, 301, 303; 248/309.1, 371, 176.3, 668; 361/679.56, 679.3, 679.25, 816; 379/426, 433.11, 455; 455/575.1, 455/575.8; 206/305, 320; 320/108, 115; 429/96; 220/4.02; 150/165; D16/101, D16/134, 136, 219, 235, 330
See application file for complete search history.

(56) **References Cited**

U.S. PATENT DOCUMENTS

D574,871 S * 8/2008 Ishii D16/219
D587,737 S * 3/2009 Chan D16/219

D603,602 S * 11/2009 Richardson et al. D3/218
D644,637 S * 9/2011 Smith et al. D14/250
D649,537 S * 11/2011 Magness et al. D14/250
D651,204 S * 12/2011 Wibby et al. D14/250
D652,855 S * 1/2012 Tsukamoto et al. D16/219
D654,489 S * 2/2012 Weller et al. D14/250
D662,923 S * 7/2012 Piedra et al. D14/250
D669,458 S * 10/2012 Wilson et al. D14/250
8,297,440 B2 * 10/2012 Schmidt et al. 206/320
D670,689 S * 11/2012 Wang D14/250
D671,102 S * 11/2012 Rothbaum et al. D14/250
8,380,264 B2 * 2/2013 Hung et al. 455/575.8
D681,619 S * 5/2013 Smith D14/250
8,457,701 B2 * 6/2013 Diebel 455/575.8
D685,776 S * 7/2013 Bau D14/250
2012/0088558 A1 * 4/2012 Song 455/575.1

* cited by examiner

Primary Examiner — Carla Jobe Wright

(57) **CLAIM**

The ornamental design for a case for electronic device, as shown and described.

DESCRIPTION

FIG. 1 is a rear isometric view of a case for electronic device showing our new design;
FIG. 2 is a rear view thereof;
FIG. 3 is an enlarged fragmentary view thereof showing the circled portion of FIG. 2; and,
FIG. 4 is an enlarged sectional view thereof taken along line 4-4 in FIG. 3.
The broken line circle that is shown both in FIGS. 2 and 3 indicates the portion of the design that is shown on an enlarged scale in FIG. 3.

1 Claim, 3 Drawing Sheets

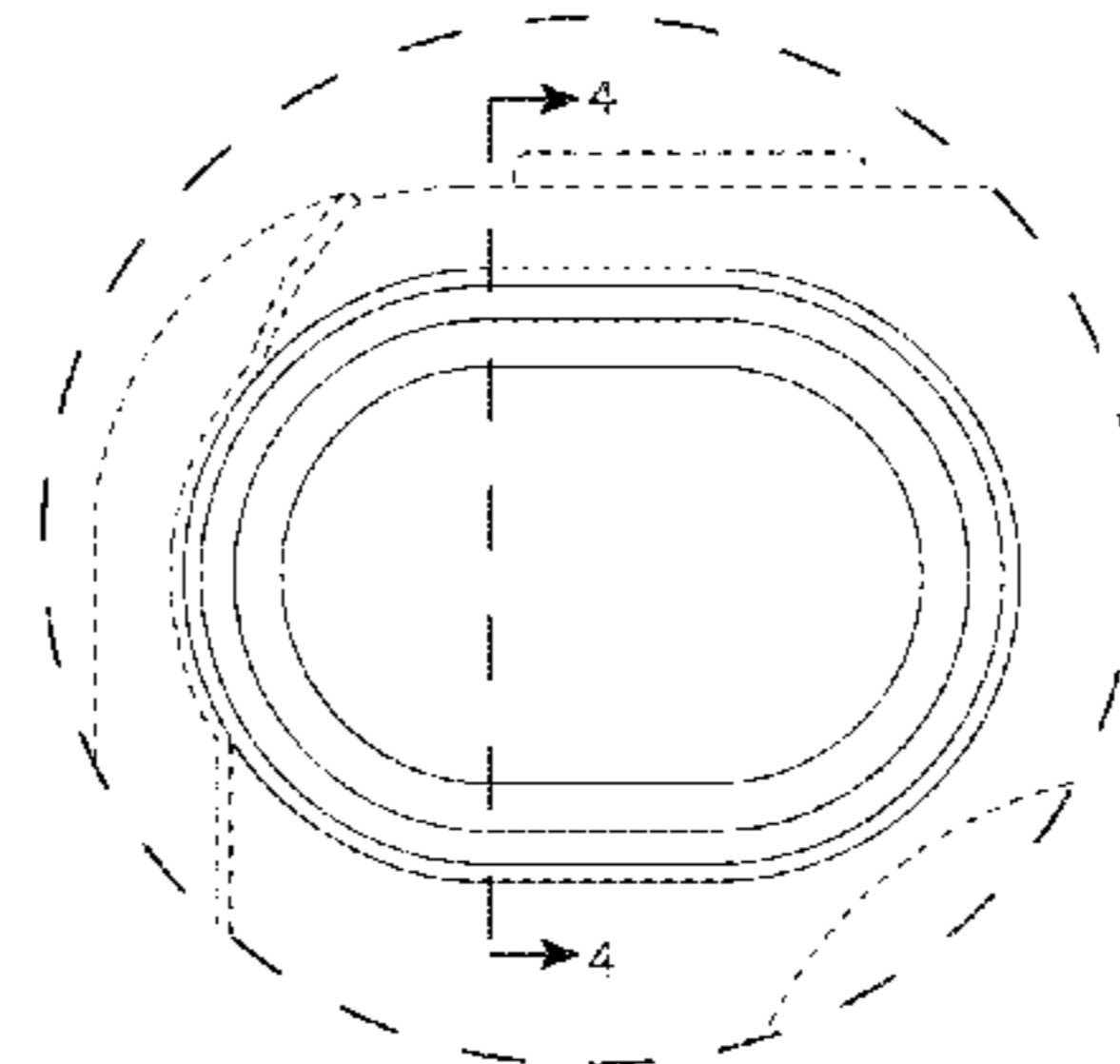
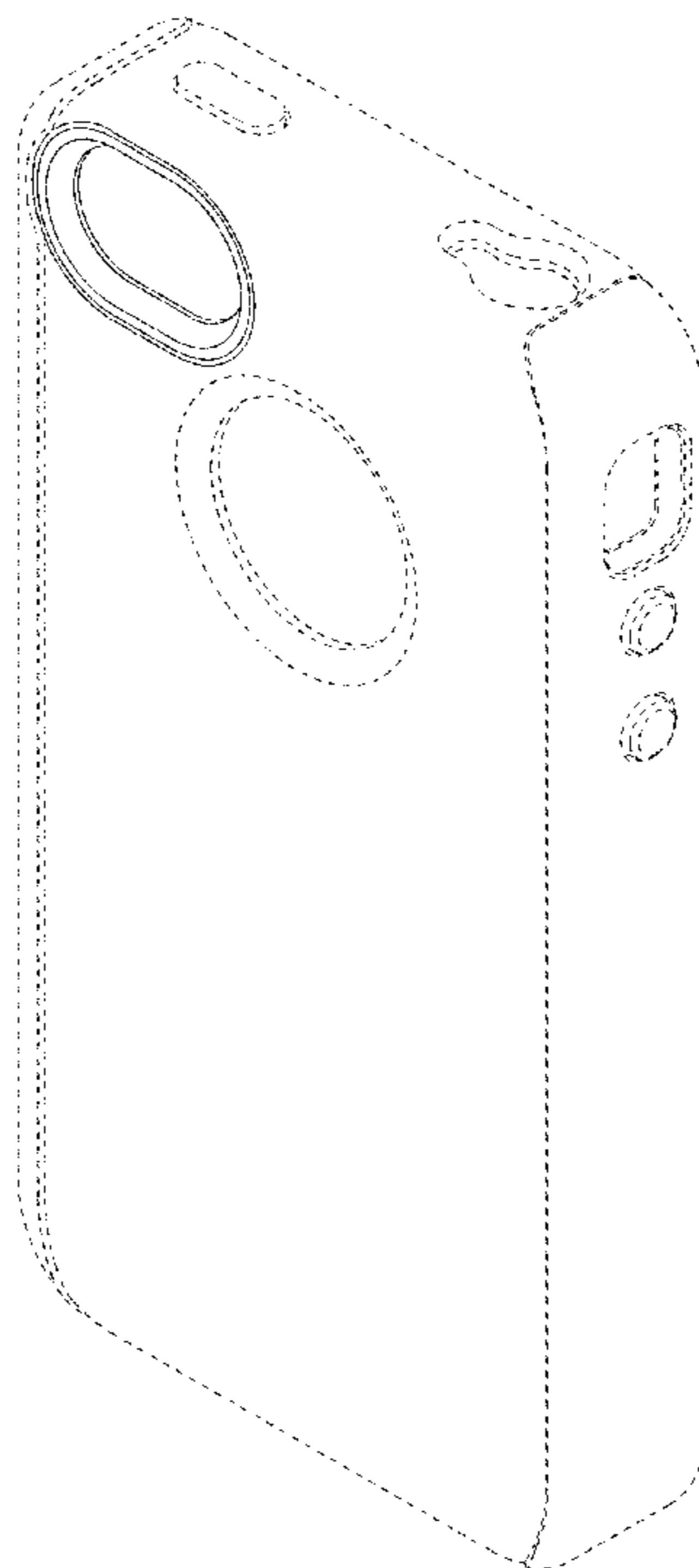

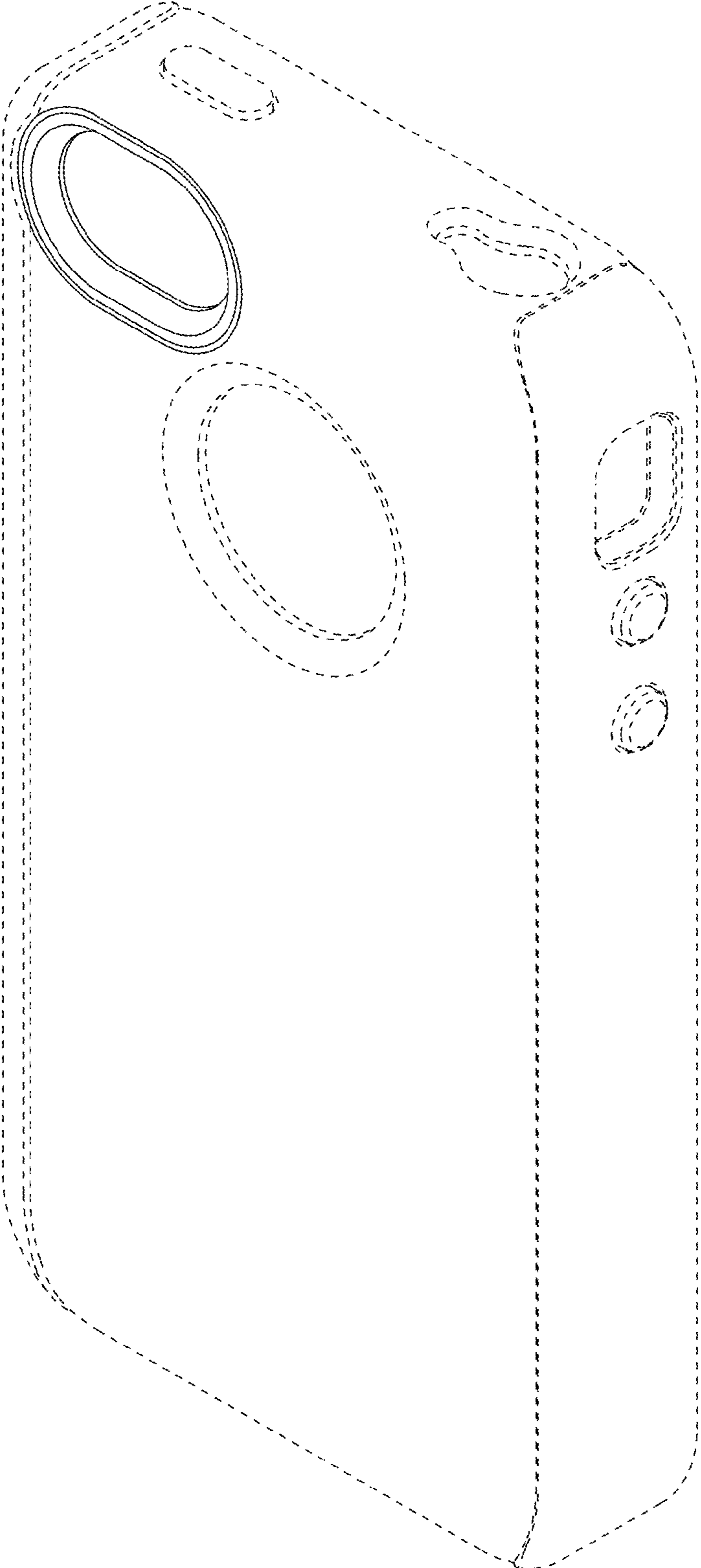

FIG. 1

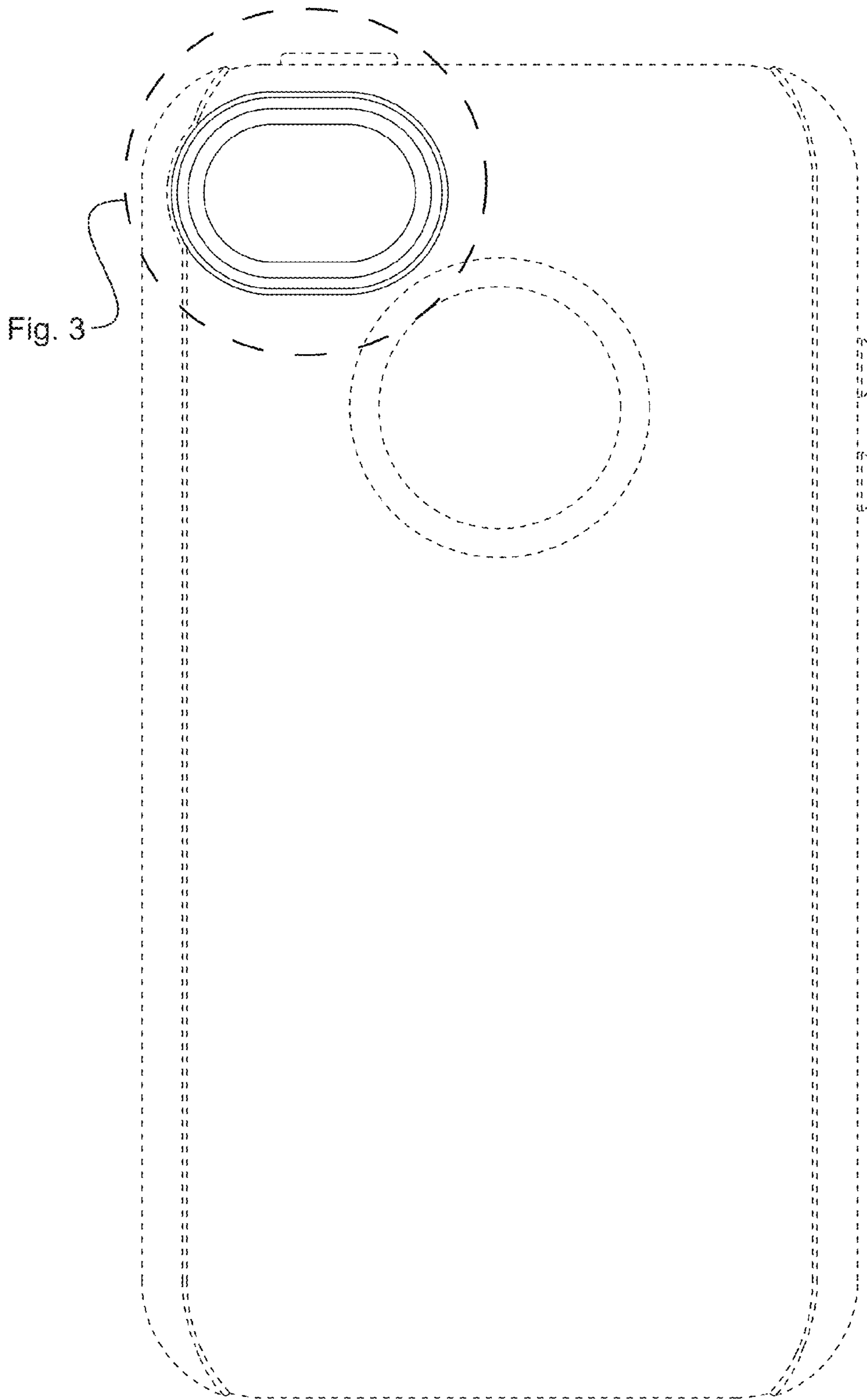

FIG. 2

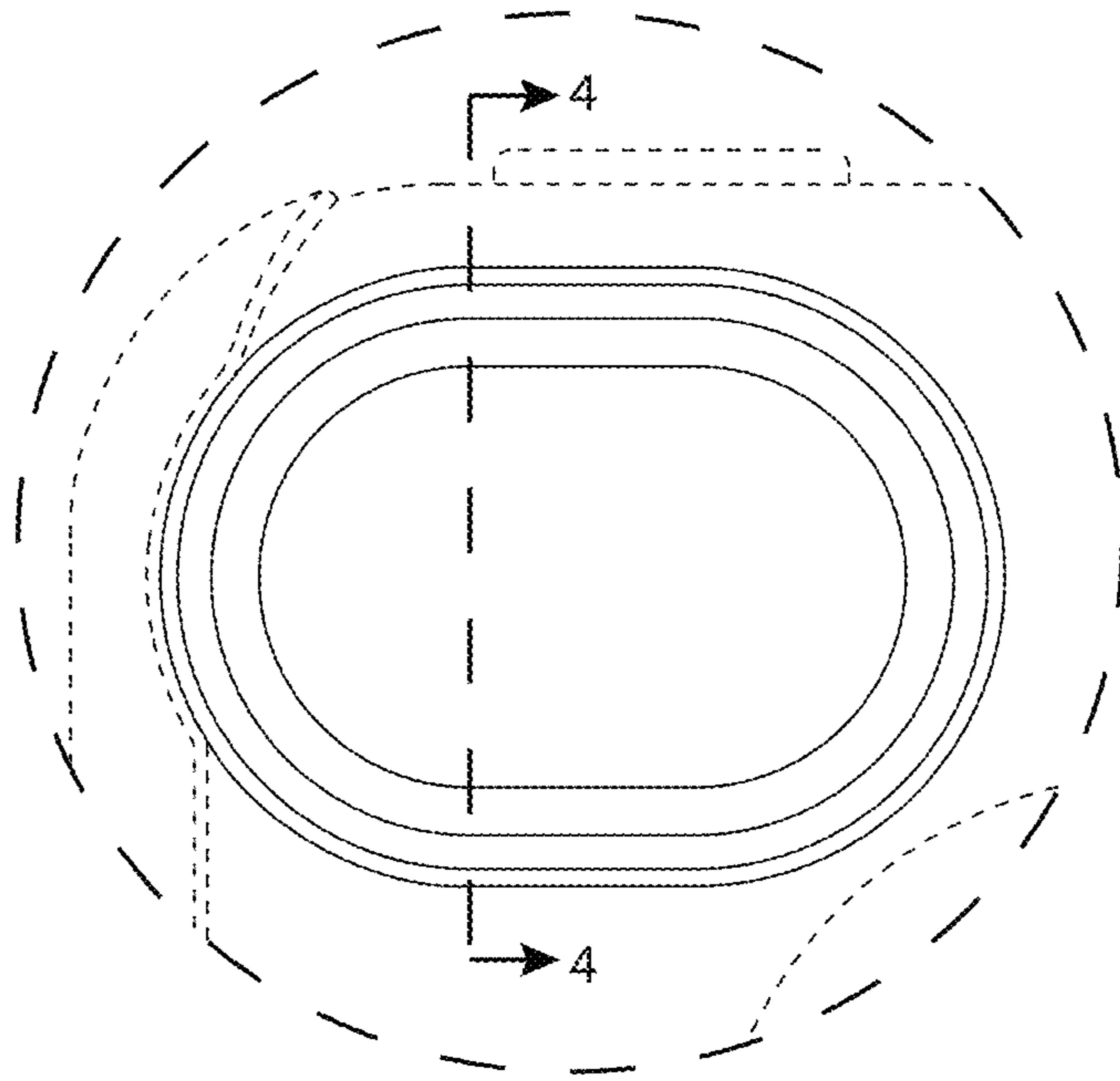

FIG. 3

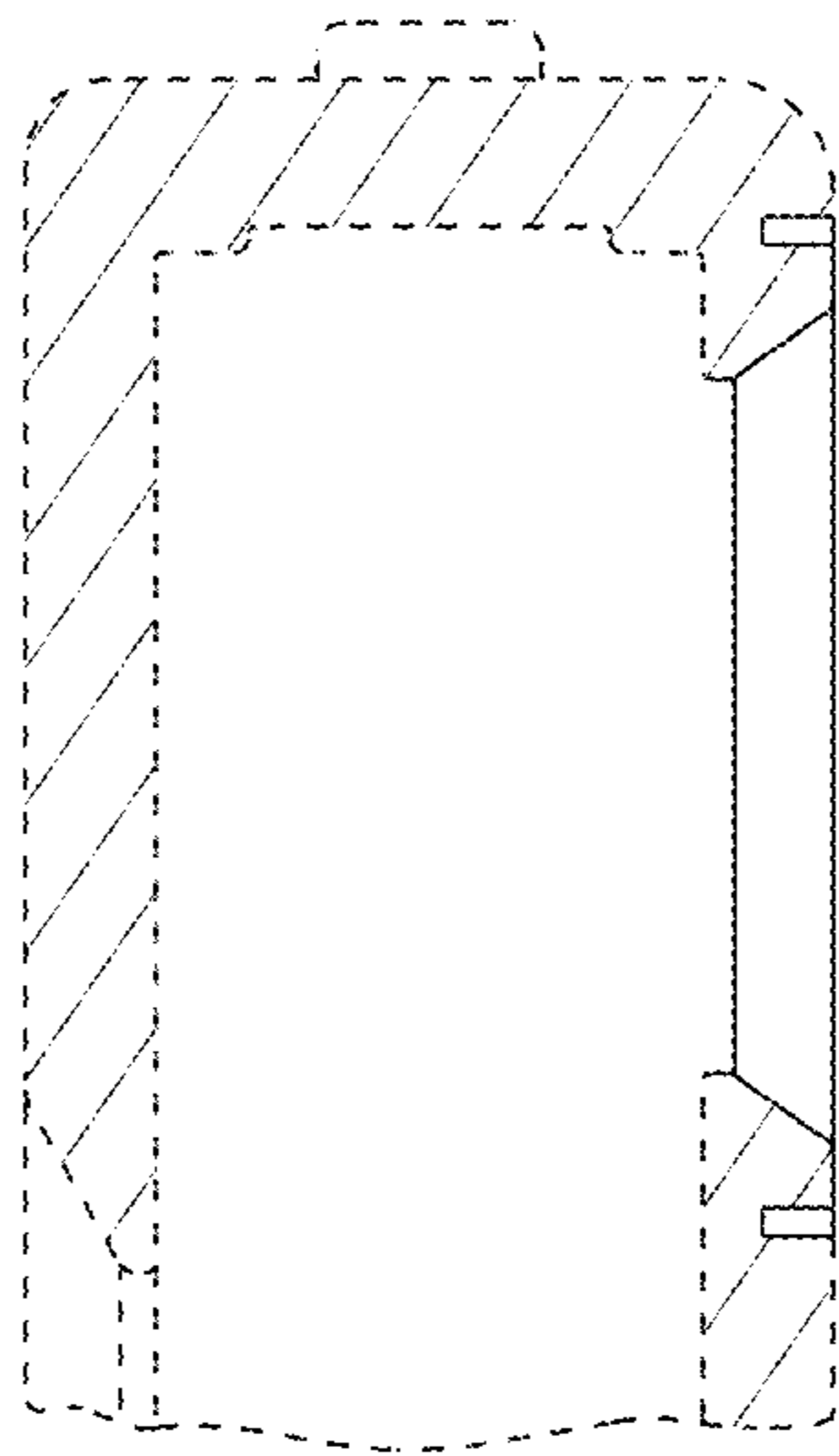

FIG. 4