



US00D703033S

(12) **United States Design Patent**  
**Karlsson**

(10) **Patent No.:** **US D703,033 S**  
(45) **Date of Patent:** **\*\* Apr. 22, 2014**

(54) **RETAINING CLAMP FOR A SPLICE BOX**

(75) Inventor: **Andreas Karlsson**, Karlskrona (SE)

(73) Assignee: **Roxtec AB**, Karlskrona (SE)

(\*\*) Term: **14 Years**

(21) Appl. No.: **29/415,548**

(22) Filed: **Mar. 12, 2012**

**Related U.S. Application Data**

(62) Division of application No. 29/366,733, filed on Jul. 29, 2010, now Pat. No. Des. 658,129.

**Foreign Application Priority Data**

(30)

Feb. 5, 2010 (EM) ..... 001666074

(51) **LOC (10) Cl.** ..... **08-08**

(52) **U.S. Cl.**

USPC ..... **D8/396**

(58) **Field of Classification Search**

USPC ..... D13/133, 139.4, 147, 152, 154, 156,  
D13/158, 160, 162-164, 173, 184, 199;  
D8/354, 356, 394, 396; 174/50, 53-55,  
174/58, 60, 66, 67; 220/3.2, 3.3, 3.7-3.9,  
220/241, 242, 244, 315; 439/135, 136, 138,  
439/142, 367, 373, 535, 536, 537, 541, 892,  
439/893; 248/49, 74.1-74.5, 73, 70, 228.8,  
248/230.8

See application file for complete search history.

(56) **References Cited**

**U.S. PATENT DOCUMENTS**

D31,044 S 6/1899 Perkins  
D183,593 S 9/1958 Atkin  
D185,057 S 5/1959 Atkin  
3,141,642 A \* 7/1964 Mayrath ..... 248/74.3

D227,989 S 7/1973 Geisel  
D243,406 S 2/1977 Mooney et al.  
4,611,873 A 9/1986 Punako et al.  
D307,541 S \* 5/1990 Tres ..... D8/396  
4,983,932 A 1/1991 Kitagawa  
D329,840 S 9/1992 Nociar  
D356,091 S 3/1995 Grande  
D361,313 S 8/1995 Sai et al.  
D364,625 S 11/1995 Grande  
D367,644 S 3/1996 Fukao et al.  
D370,889 S 6/1996 Anthony  
D389,052 S \* 1/1998 Yamamoto ..... D8/396  
D392,618 S 3/1998 Fukao et al.  
D414,405 S \* 9/1999 Tompkins ..... D8/396  
D439,563 S 3/2001 Shimojo

(Continued)

**OTHER PUBLICATIONS**

Notice of Allowance for related U.S. Appl. No. 29/415,550 dated Sep. 11, 2013.

(Continued)

*Primary Examiner* — Rosemary K Tarcza

(74) *Attorney, Agent, or Firm* — Harness, Dickey & Pierce, P.L.C.

(57)

**CLAIM**

The ornamental design for a retaining clamp for a splice box, as shown and described.

**DESCRIPTION**

FIG. 1 is a top perspective view of a retaining clamp for a splice box;  
FIG. 2 is a first side view thereof;  
FIG. 3 is a top plan view thereof;  
FIG. 4 is a second side view thereof;  
FIG. 5 is a bottom plan view thereof;  
FIG. 6 is a third side view thereof; and,  
FIG. 7 is a fourth side view thereof.

**1 Claim, 4 Drawing Sheets**

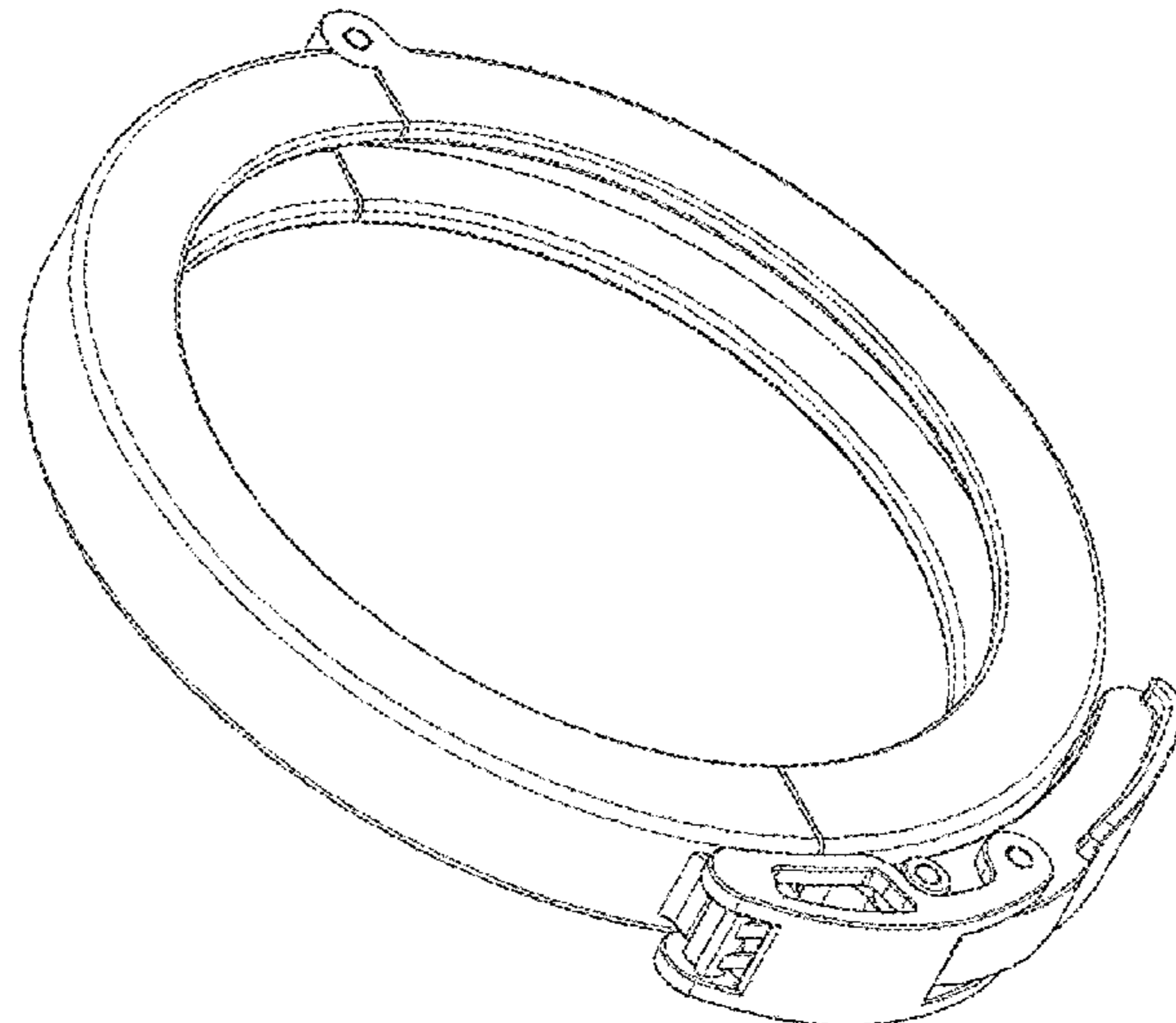

(56)

**References Cited**

U.S. PATENT DOCUMENTS

D449,581 S 10/2001 Bosatelli  
D467,878 S 12/2002 Bryndzia  
D478,872 S 8/2003 Heggem  
D484,097 S 12/2003 Drane et al.  
D526,973 S 8/2006 Gates et al.  
D552,558 S 10/2007 Kelly et al.  
D560,610 S 1/2008 McCoy  
D577,423 S \* 9/2008 Dole ..... D23/265  
D580,371 S 11/2008 Farahani  
D584,604 S \* 1/2009 Baldwin ..... D8/396  
D585,837 S 2/2009 Keuhne et al.  
D614,138 S 4/2010 Blixt  
D618,176 S 6/2010 Kato et al.

D636,736 S 4/2011 Otasu et al.  
D642,045 S \* 7/2011 Sweeney ..... D8/356  
D647,394 S \* 10/2011 Taylor ..... D8/396  
D653,103 S \* 1/2012 Tomasi et al. .... D8/396  
D653,530 S \* 2/2012 Hammond et al. .... D8/396  
D658,129 S 4/2012 Karlsson  
D665,247 S \* 8/2012 Hammond et al. .... D8/396  
D672,229 S \* 12/2012 Reid ..... D8/396  
D676,738 S \* 2/2013 Hammond et al. .... D8/396  
D687,384 S 8/2013 Kazakia

OTHER PUBLICATIONS

Office Action for related U.S. Appl. No. 29/415,545 dated Sep. 12, 2013.

\* cited by examiner

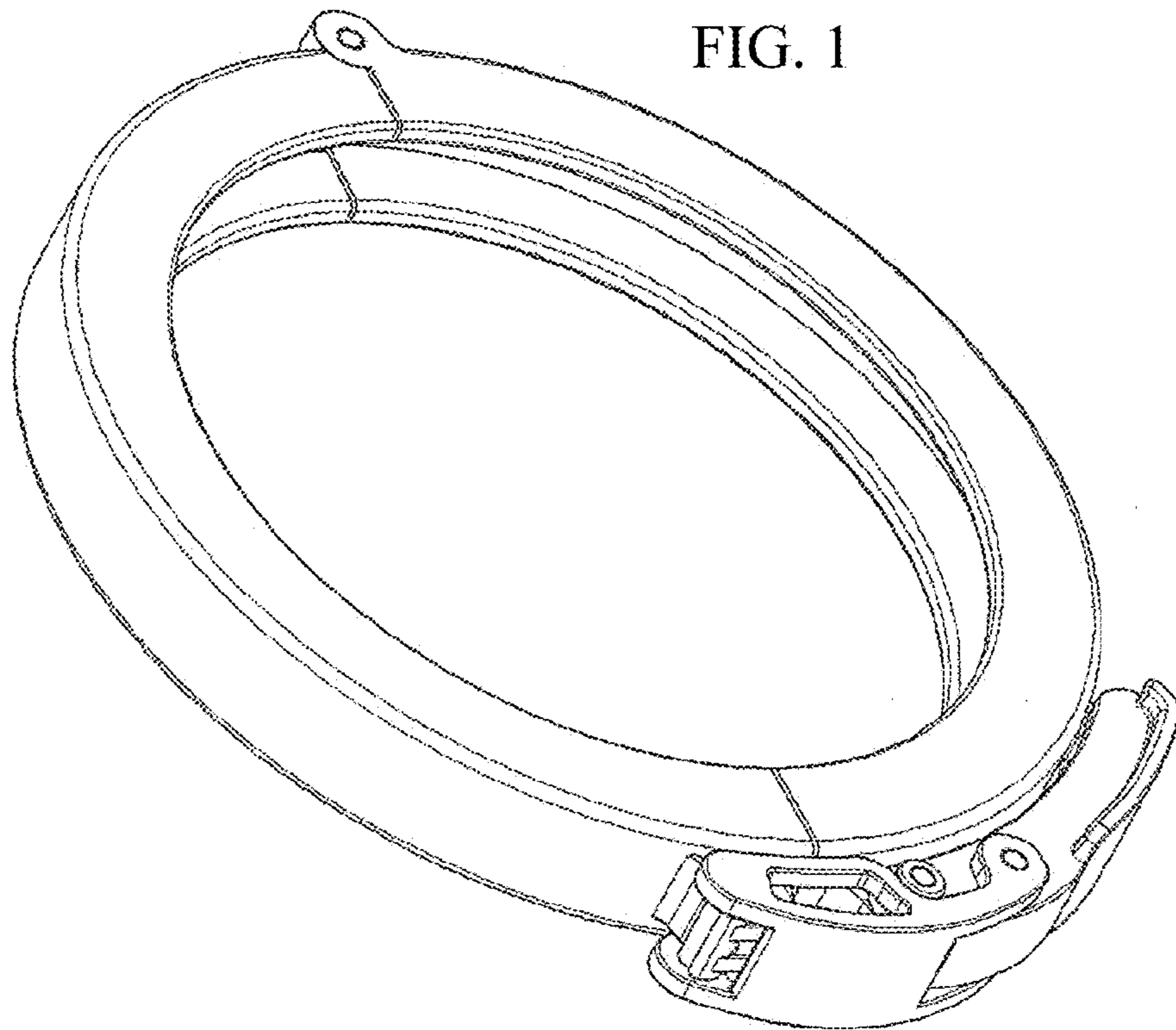

FIG. 1



FIG. 2

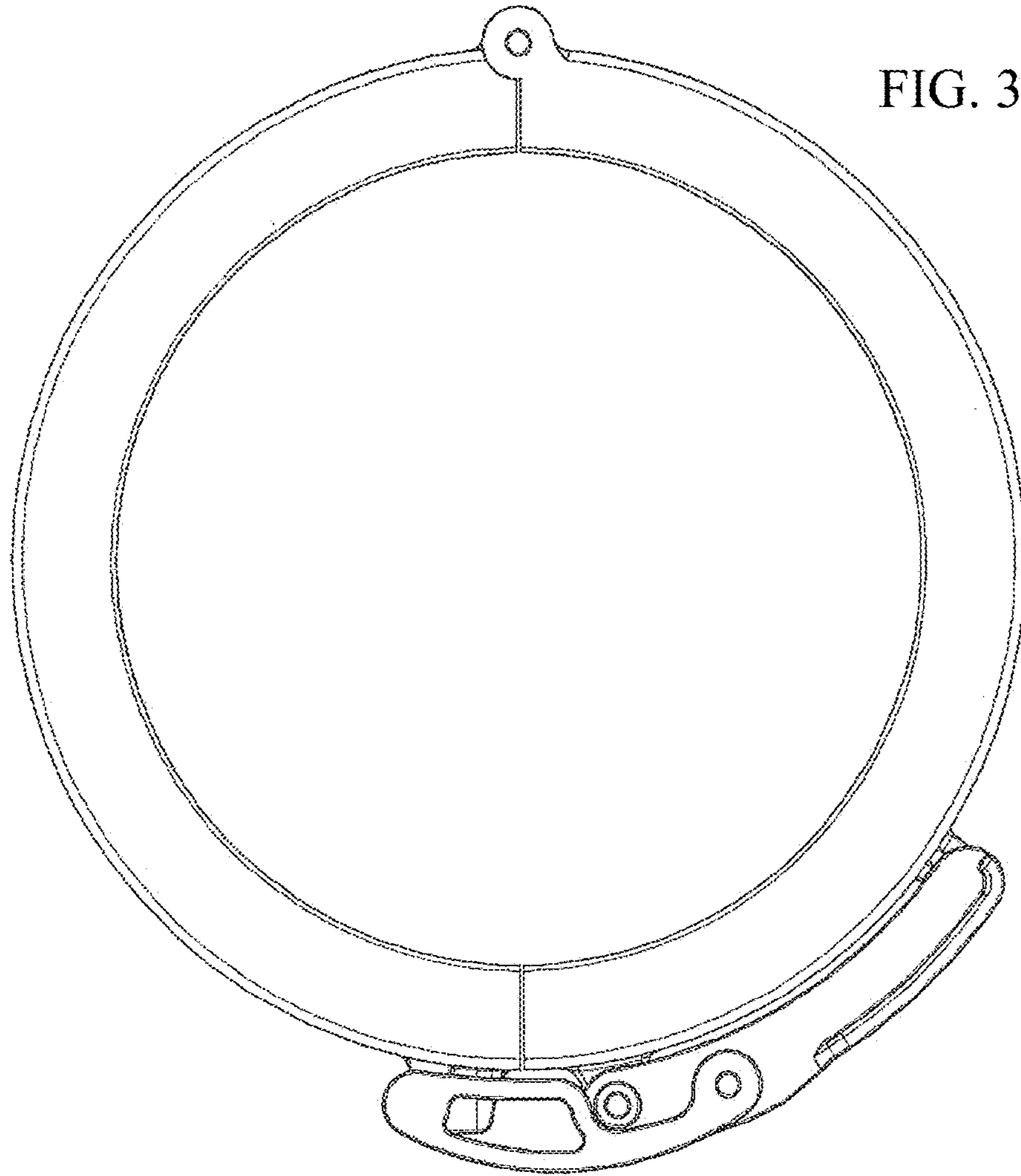

FIG. 3

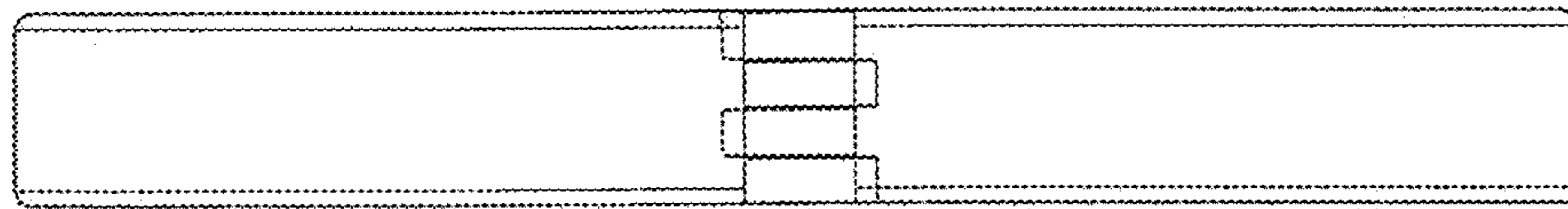

FIG. 4



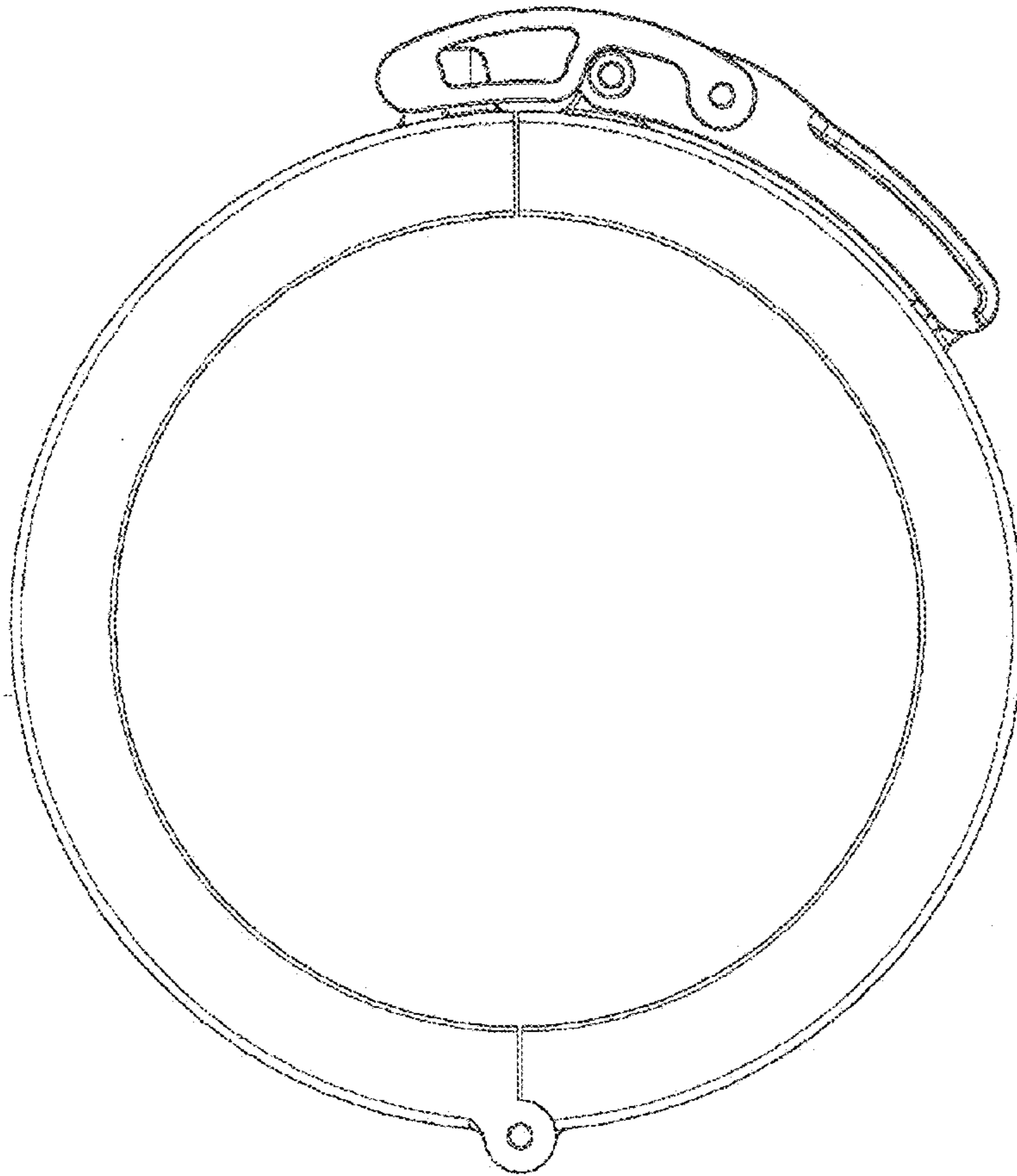

FIG. 5

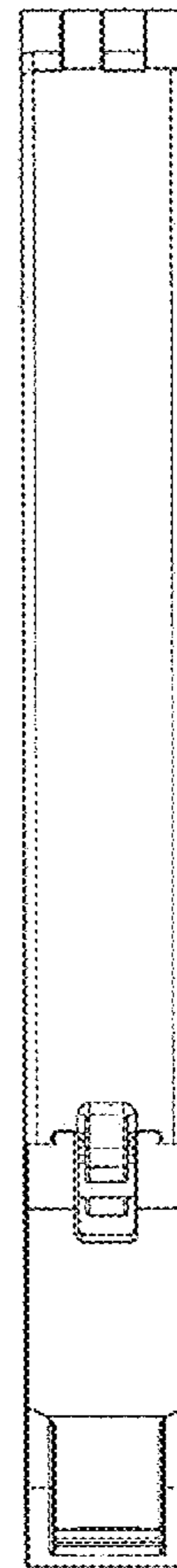

FIG. 6

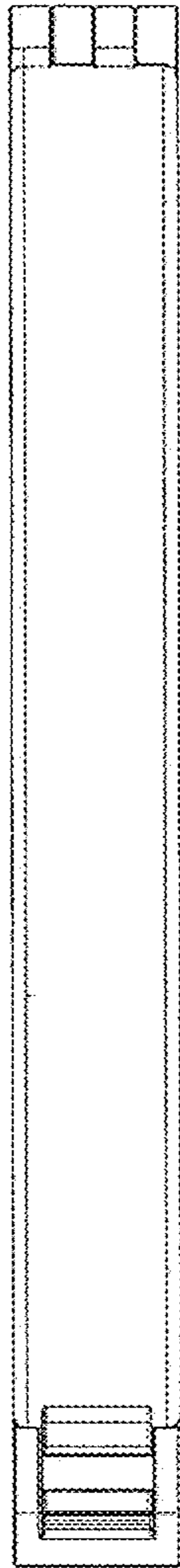

FIG. 7