



US00D702600S

(12) **United States Design Patent**
Akojima

(10) **Patent No.:** **US D702,600 S**

(45) **Date of Patent:** **** Apr. 15, 2014**

(54) **GRILL FOR AN AUTOMOBILE**
(71) Applicant: **Honda Motor Co., Ltd.**, Tokyo (JP)
(72) Inventor: **Daisuke Akojima**, Wako (JP)
(73) Assignee: **Honda Motor Co., Ltd.**, Tokyo (JP)
(**) Term: **14 Years**

D584,197 S *	1/2009	Song et al.	D12/163
D586,267 S *	2/2009	Ebel et al.	D12/163
D593,460 S *	6/2009	Schiavone et al.	D12/163
D619,057 S *	7/2010	George et al.	D12/163
D626,897 S *	11/2010	Ectors et al.	D12/163
D644,965 S *	9/2011	Tonello	D12/163
D644,966 S *	9/2011	Tonello	D12/163
D644,967 S *	9/2011	Tonello	D12/163
D664,484 S *	7/2012	Kawaguchi	D12/169
D680,921 S *	4/2013	Jara	D12/163
D692,803 S *	11/2013	Nakahara	D12/163

(21) Appl. No.: **29/437,693**

* cited by examiner

(22) Filed: **Nov. 20, 2012**

Primary Examiner — Melody Brown

(30) **Foreign Application Priority Data**

(74) *Attorney, Agent, or Firm* — Plumsea Law Group, LLC

May 25, 2012 (JP) 2012-012392

(51) **LOC (10) Cl.** **12-16**

(52) **U.S. Cl.**
USPC **D12/163**

(58) **Field of Classification Search**
USPC D12/163, 196, 171, 169, 216, 90-92,
D12/86; 180/68.1, 68.6; 296/193.11
See application file for complete search history.

(57) **CLAIM**

The ornamental design for a grill for an automobile, as shown and described.

(56) **References Cited**

DESCRIPTION

U.S. PATENT DOCUMENTS

FIG. 1 is a perspective view of a grill for an automobile, showing our new design;
FIG. 2 is a top front elevation view thereof;
FIG. 3 is a top plan view thereof; and,
FIG. 4 is a right side elevation view thereof.
The broken lines are for illustrative purposes only and form no part of the claimed design.

D578,443 S *	10/2008	Schiavone et al.	D12/163
D584,196 S *	1/2009	Ebel et al.	D12/163

1 Claim, 4 Drawing Sheets

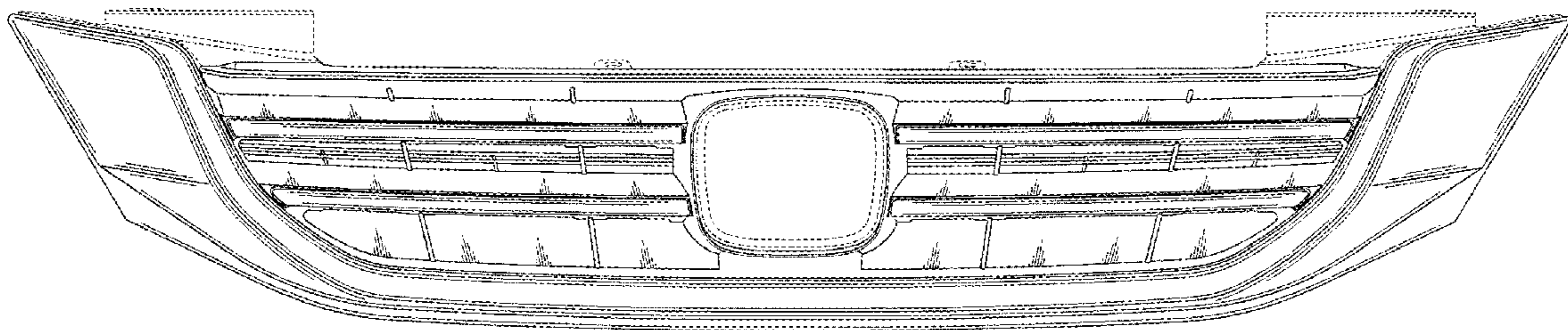

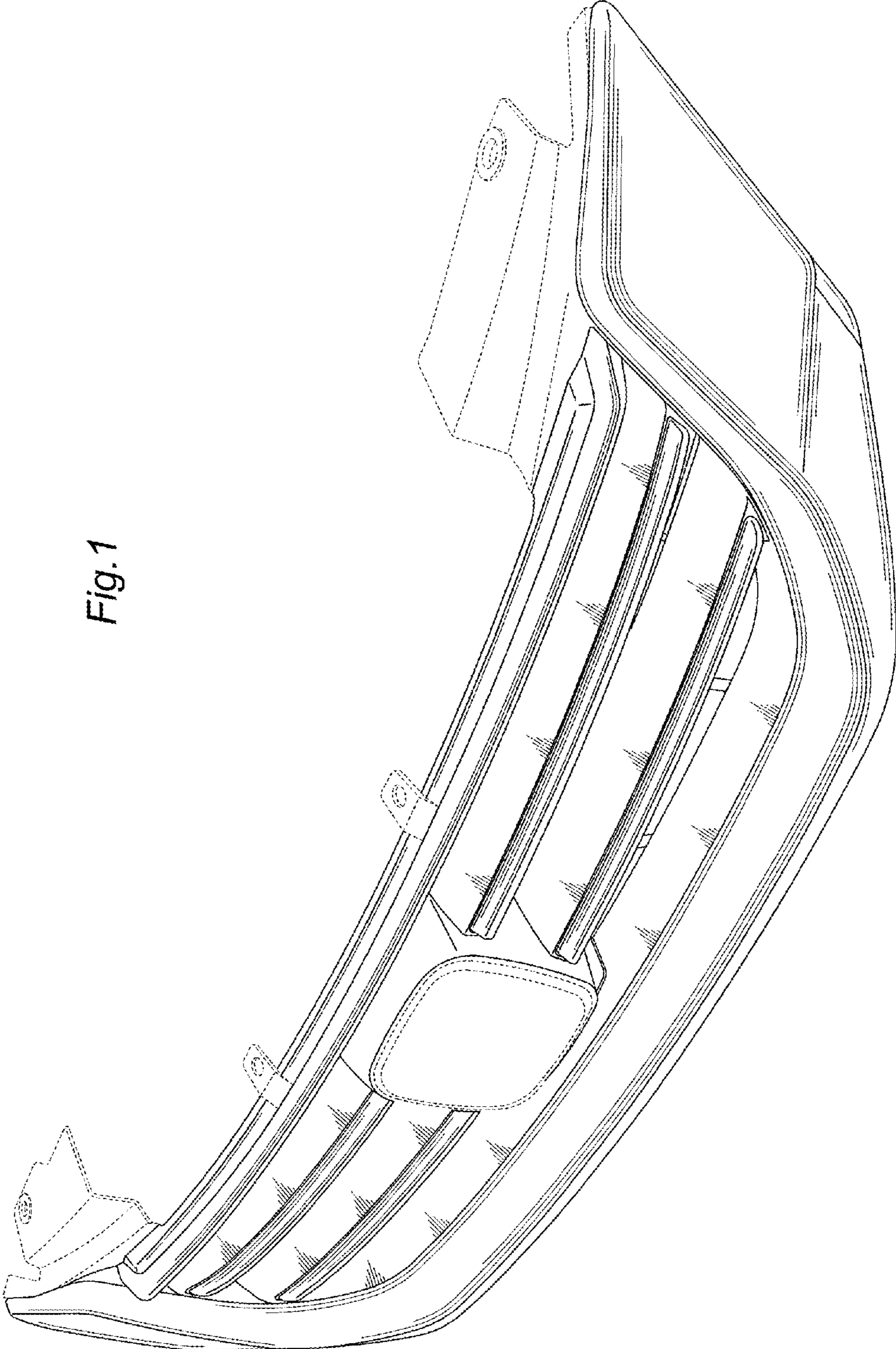

Fig. 1

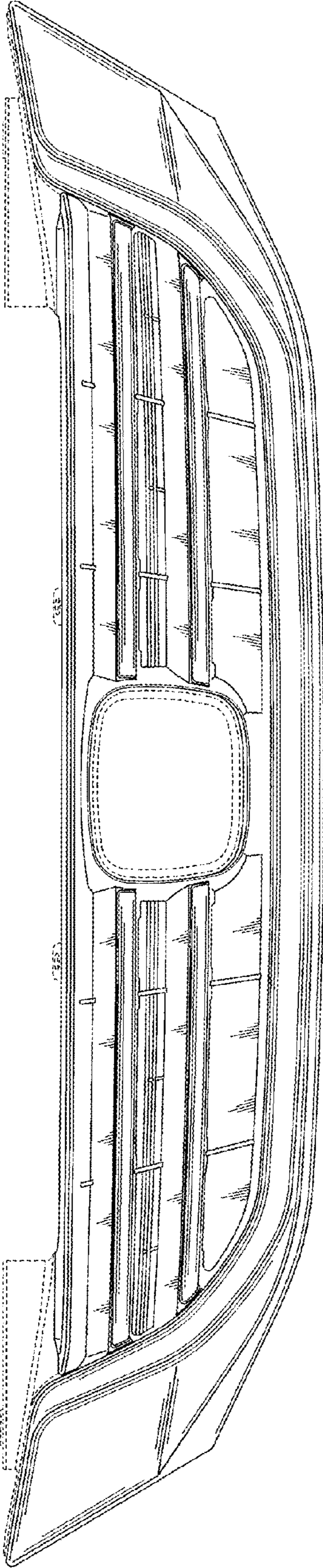

Fig.2

Fig.3

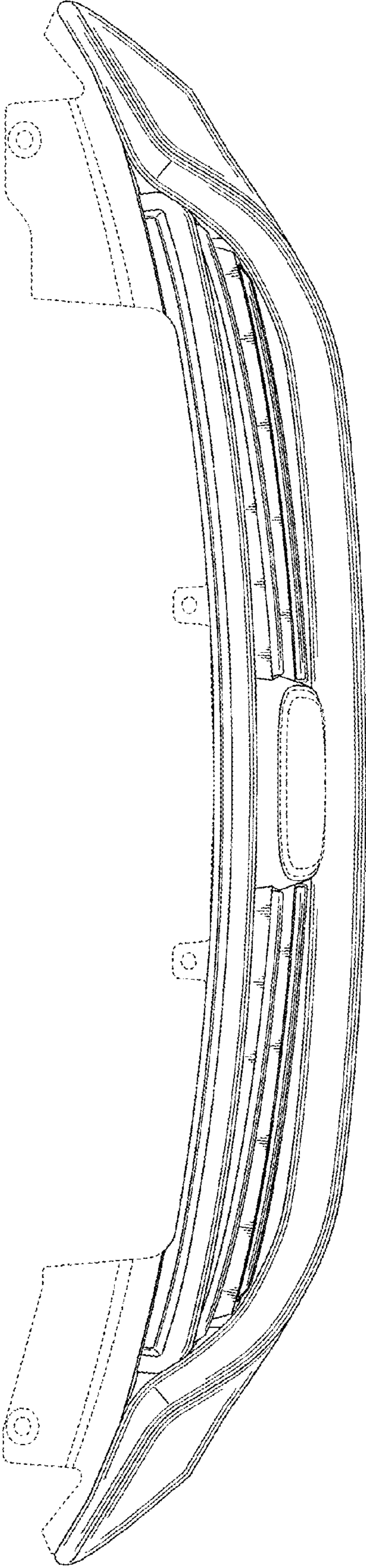

Fig. 4

