



US00D702272S

(12) **United States Design Patent**  
**Furujo et al.**

(10) **Patent No.:** **US D702,272 S**  
(45) **Date of Patent:** **\*\* Apr. 8, 2014**

(54) **OUTER NOZZLE FOR PLASMA TORCH**  
(75) Inventors: **Akira Furujo**, Tokyo (JP); **Masatoshi Motoyama**, Tokyo (JP); **Ryuta Hirai**, Tokyo (JP); **Kazuya Kashimata**, Isezaki (JP); **Tetsuo Koike**, Tokyo (JP)

(73) Assignee: **Koike Sanso Kogyo Co., Ltd.**, Tokyo (JP)

(\*\*) Term: **14 Years**

(21) Appl. No.: **29/429,584**

(22) Filed: **Aug. 14, 2012**

**Related U.S. Application Data**

(62) Division of application No. 29/375,811, filed on Sep. 28, 2010, now Pat. No. Des. 687,874.

(51) **LOC (10) Cl.** ..... **15-09**

(52) **U.S. Cl.**  
USPC ..... **D15/144**

(58) **Field of Classification Search**  
USPC ..... D15/144-144.2; 219/121.4-121.5,  
219/121.52, 121.57  
See application file for complete search history.

(56) **References Cited**

**U.S. PATENT DOCUMENTS**

5,798,496	A *	8/1998	Eckhoff et al.	219/121.36
5,856,647	A *	1/1999	Luo	219/121.5
D505,963	S *	6/2005	Conway et al.	D15/139
D517,577	S *	3/2006	Conway et al.	D15/144
D535,672	S *	1/2007	MacKenzie et al.	D15/144
7,176,404	B2 *	2/2007	Herres	219/121.5
7,326,874	B2 *	2/2008	Brasseur et al.	219/121.5
D582,951	S *	12/2008	Yamaguchi et al.	D15/144
D652,437	S *	1/2012	Furujo et al.	D15/144
D653,270	S *	1/2012	Furujo et al.	D15/144
8,089,025	B2 *	1/2012	Sanders	219/121.5
D654,104	S *	2/2012	Fitzpatrick et al.	D15/144
D654,939	S *	2/2012	Furujo et al.	D15/144
D654,940	S *	2/2012	Furujo et al.	D15/144
2004/0000538	A1 *	1/2004	Conway et al.	219/121.48

2007/0173007	A1 *	7/2007	Lee et al.	438/209
2009/0057277	A1 *	3/2009	Renault et al.	219/121.5
2010/0237050	A1 *	9/2010	Zehavi	219/121.47
2010/0264120	A1 *	10/2010	Reinke et al.	219/121.5
2011/0198320	A1 *	8/2011	Mather et al.	219/121.48
2011/0259855	A1 *	10/2011	Yang	219/121.5

\* cited by examiner

*Primary Examiner* — Patricia Palasik

(74) *Attorney, Agent, or Firm* — Smith Patent Office

(57) **CLAIM**

The ornamental design for an outer nozzle for plasma torch, as shown and described herein.

**DESCRIPTION**

FIG. 1 is a perspective view of the outer nozzle for a plasma torch showing our design;  
FIG. 2 is a side view thereof;  
FIG. 3 is a side view thereof;  
FIG. 4 is a top view thereof;  
FIG. 5 is a bottom view thereof;  
FIG. 6 is a rear view thereof;  
FIG. 7 is a front view thereof;  
FIG. 8 is a cross-sectional view taken along line 8-8 of FIG. 7;  
FIG. 9 is a cross-sectional view taken along line 9-9 of FIG. 2;  
and,

FIG. 10 is an exploded view of the components making up the plasma torch including the outer nozzle. This exploded view shows the plasma torch, inner cap therefor, inner nozzle therefor, inner cap therefor, electrode therefor, and the outer nozzle for same as claimed herein, illustrating the position of the outer nozzle relative to same. The claimed design is shown in solid lines. The broken lines in the drawings depict unclaimed environmental subject matter.

In particular, the claimed article is an outer nozzle used with a plasma torch for high temperature cutting applications, such as cutting of metals. The claimed article is partially expended (worn) during use, and replaced as needed. Therefore, the claimed article may be sold separately from the plasma torch, and distributed separately in the market place.

**1 Claim, 10 Drawing Sheets**

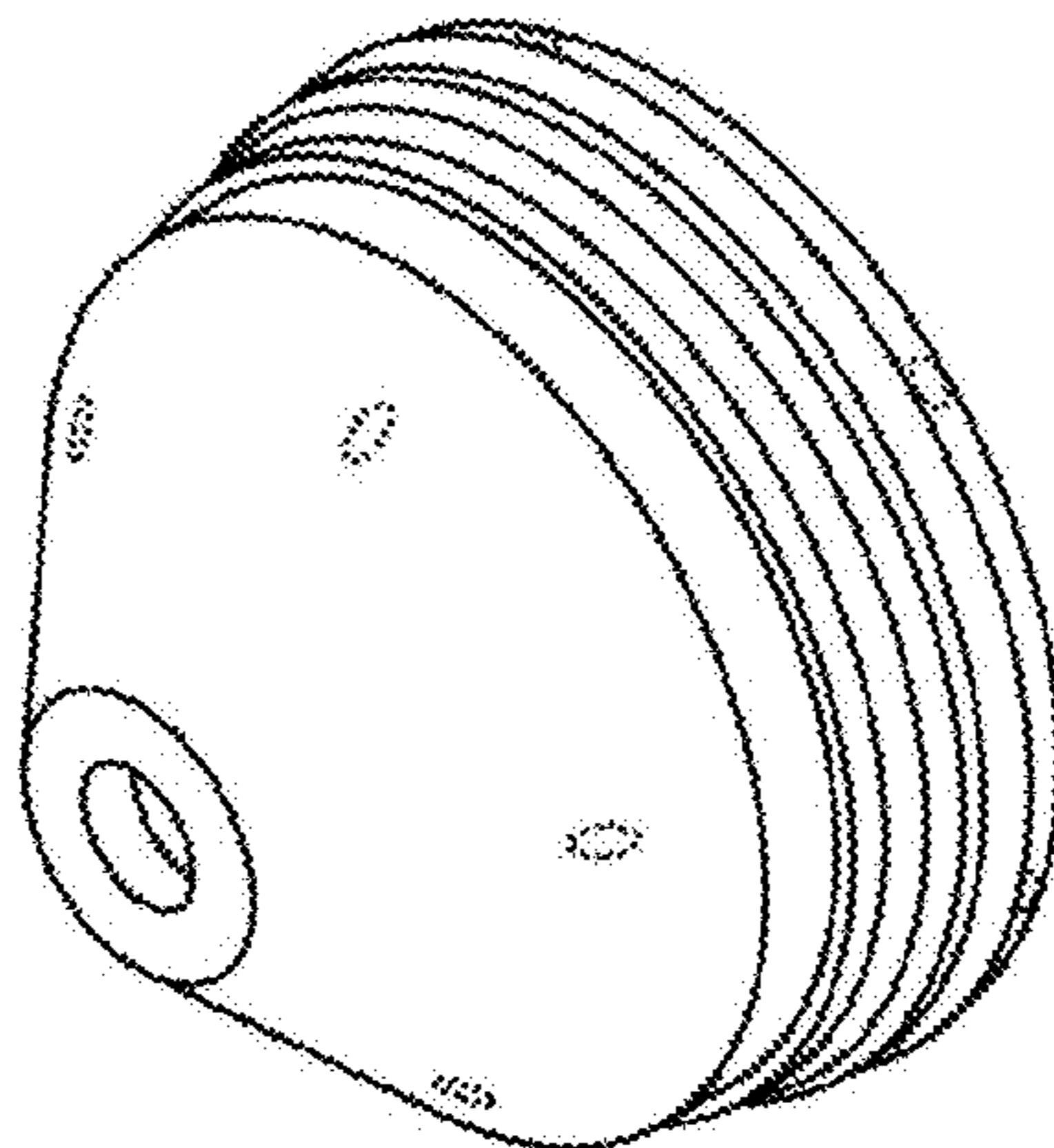

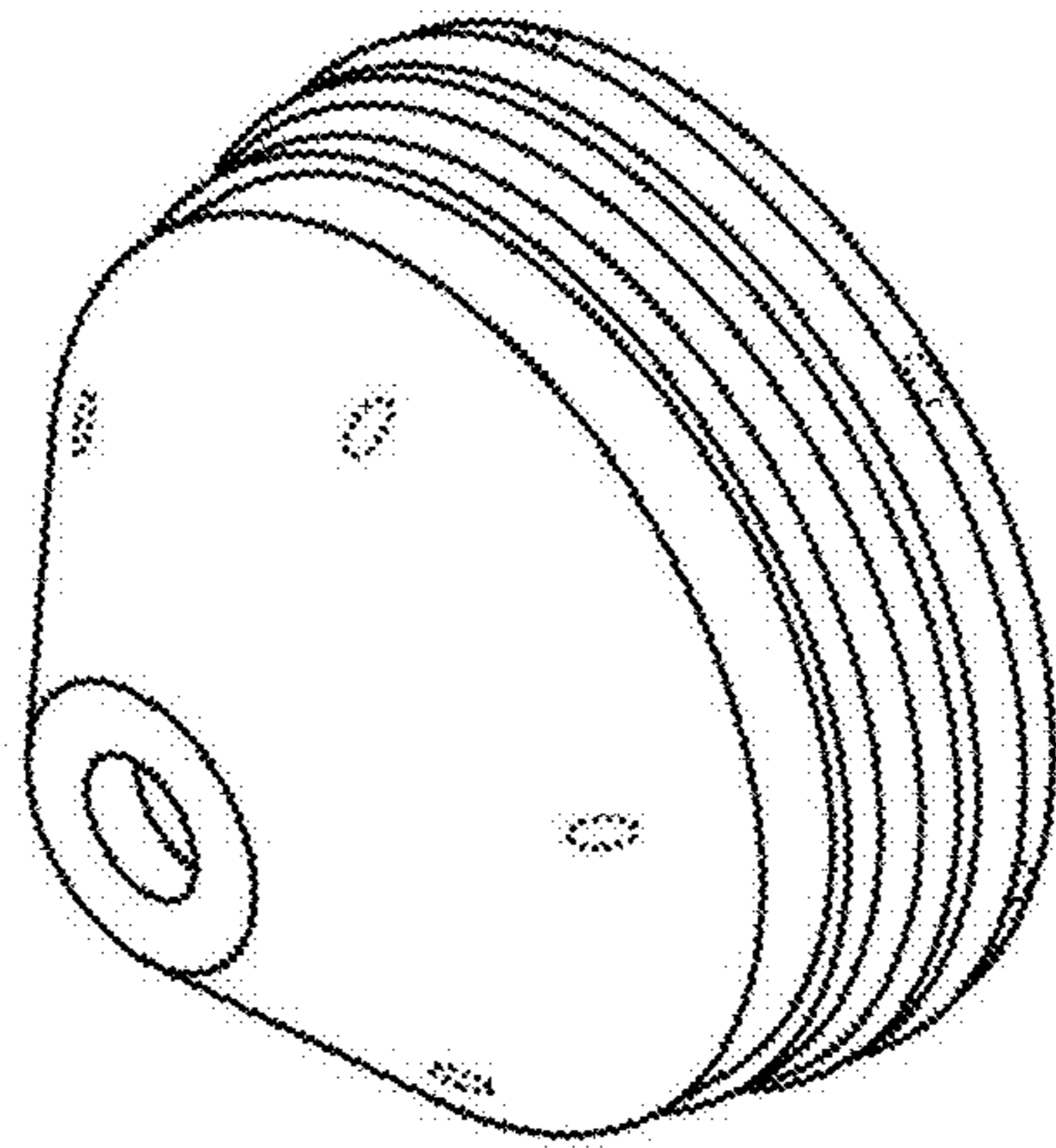

Fig. 1

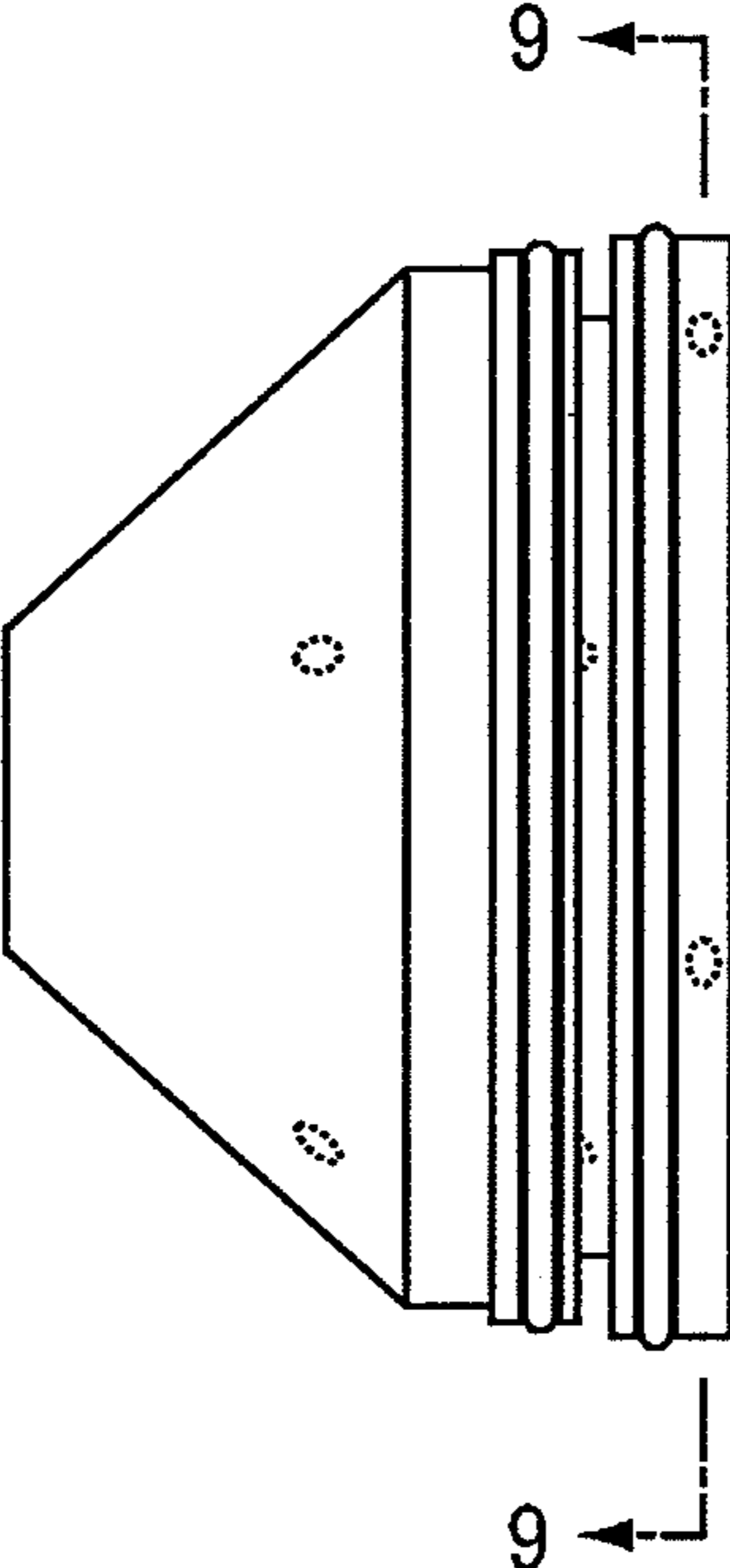

Fig. 2

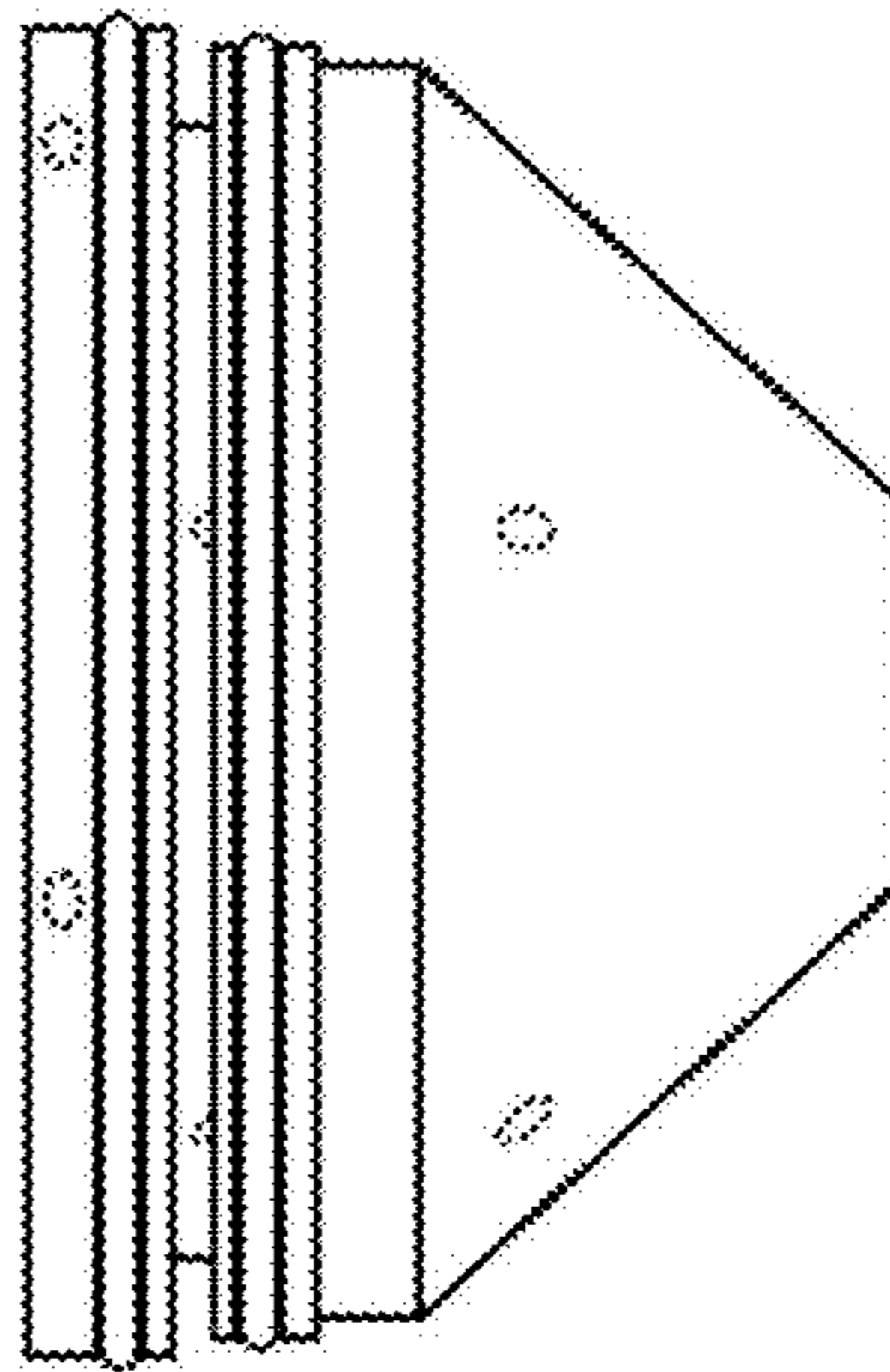

Fig. 3

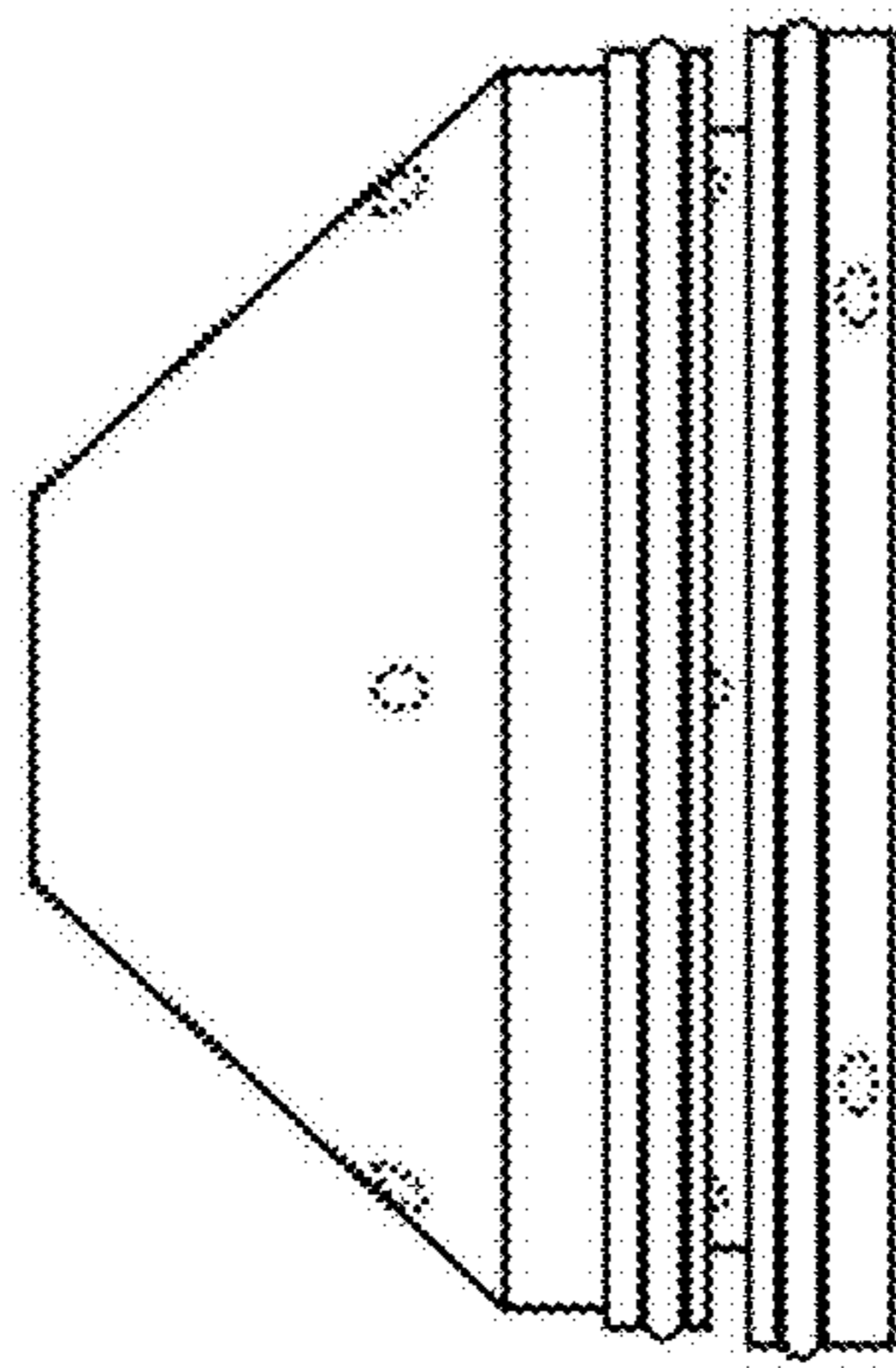

Fig. 4

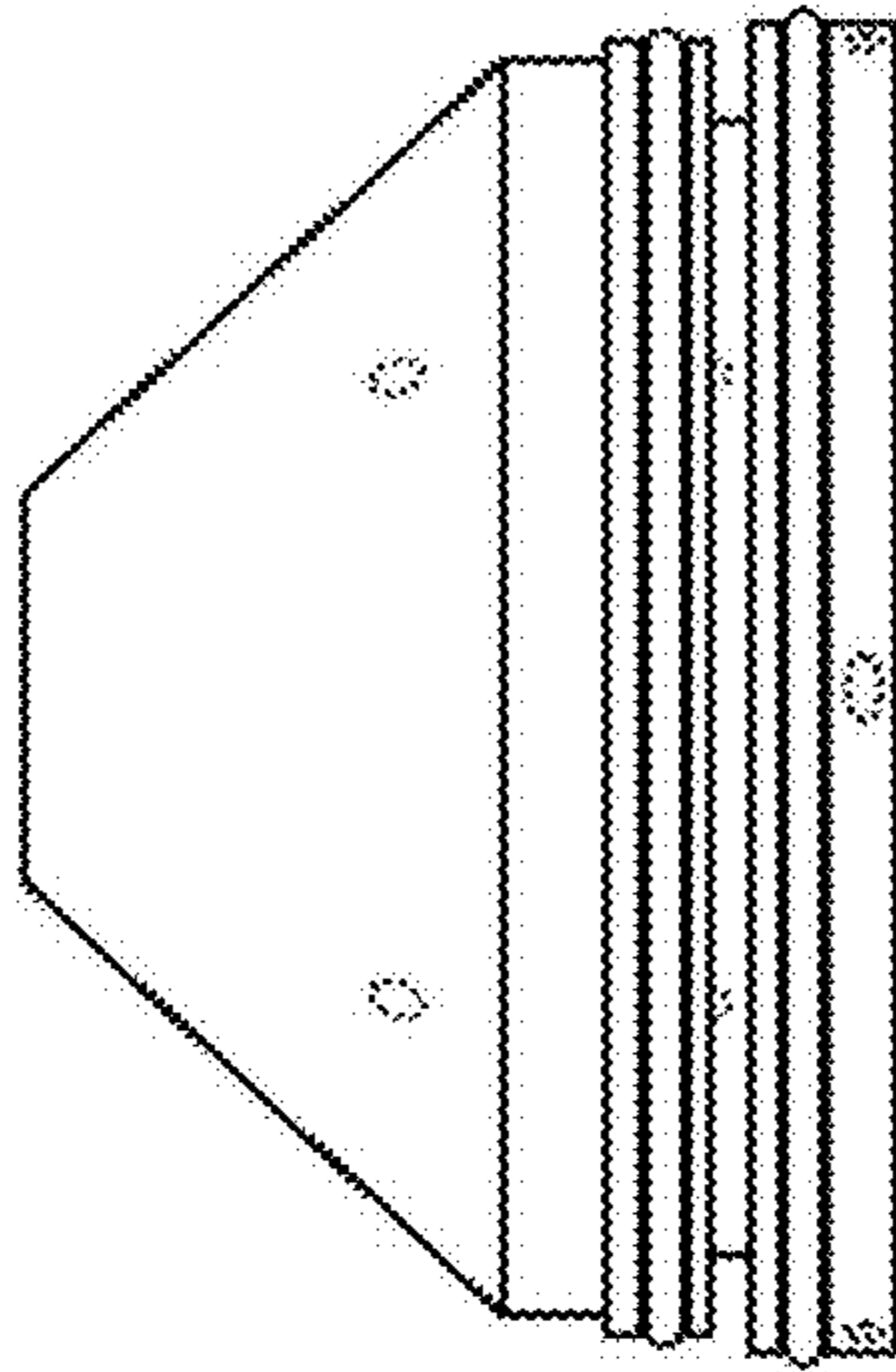

Fig. 5

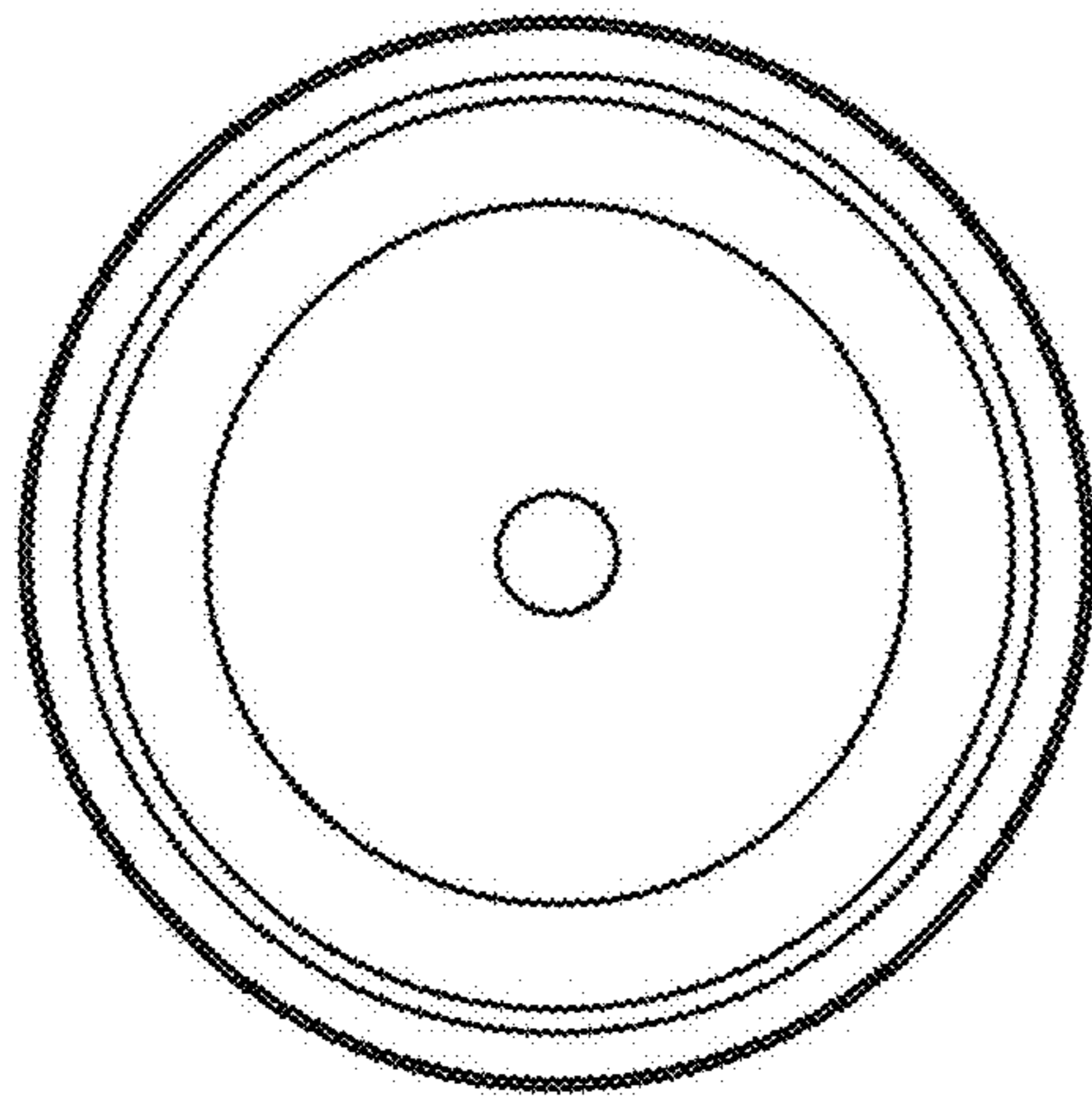

Fig. 6

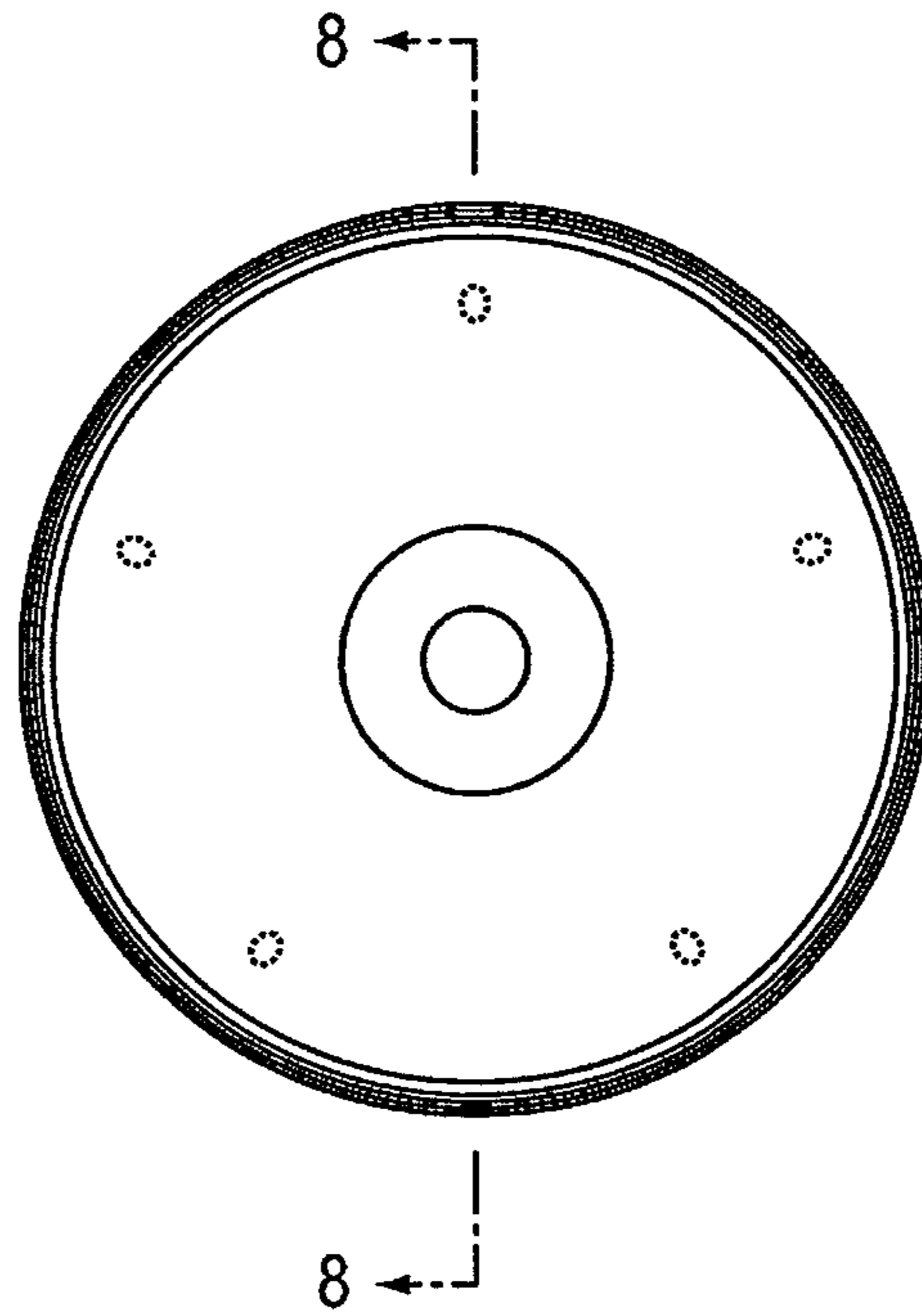

Fig. 7



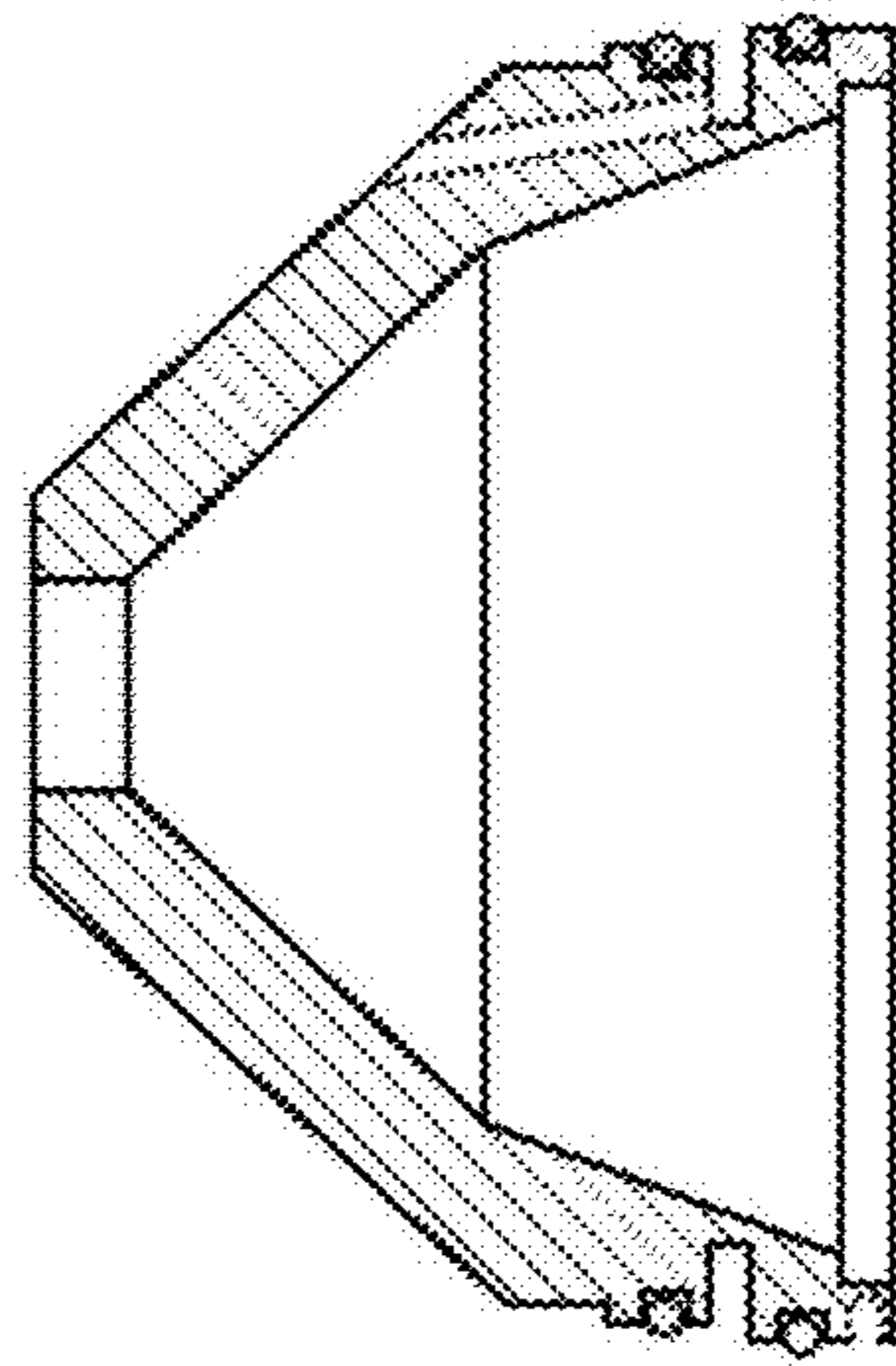

Fig. 8

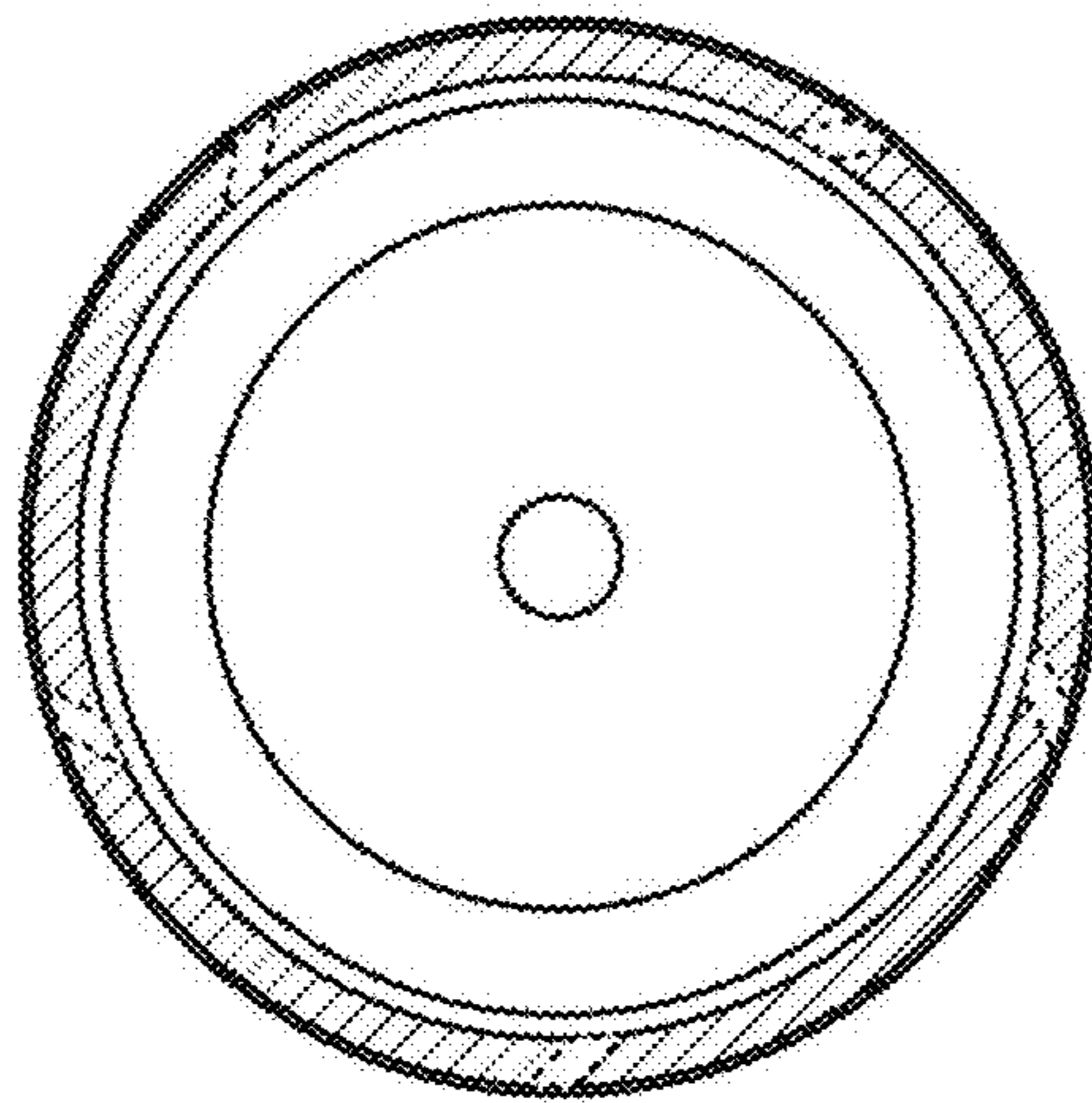

Fig. 9

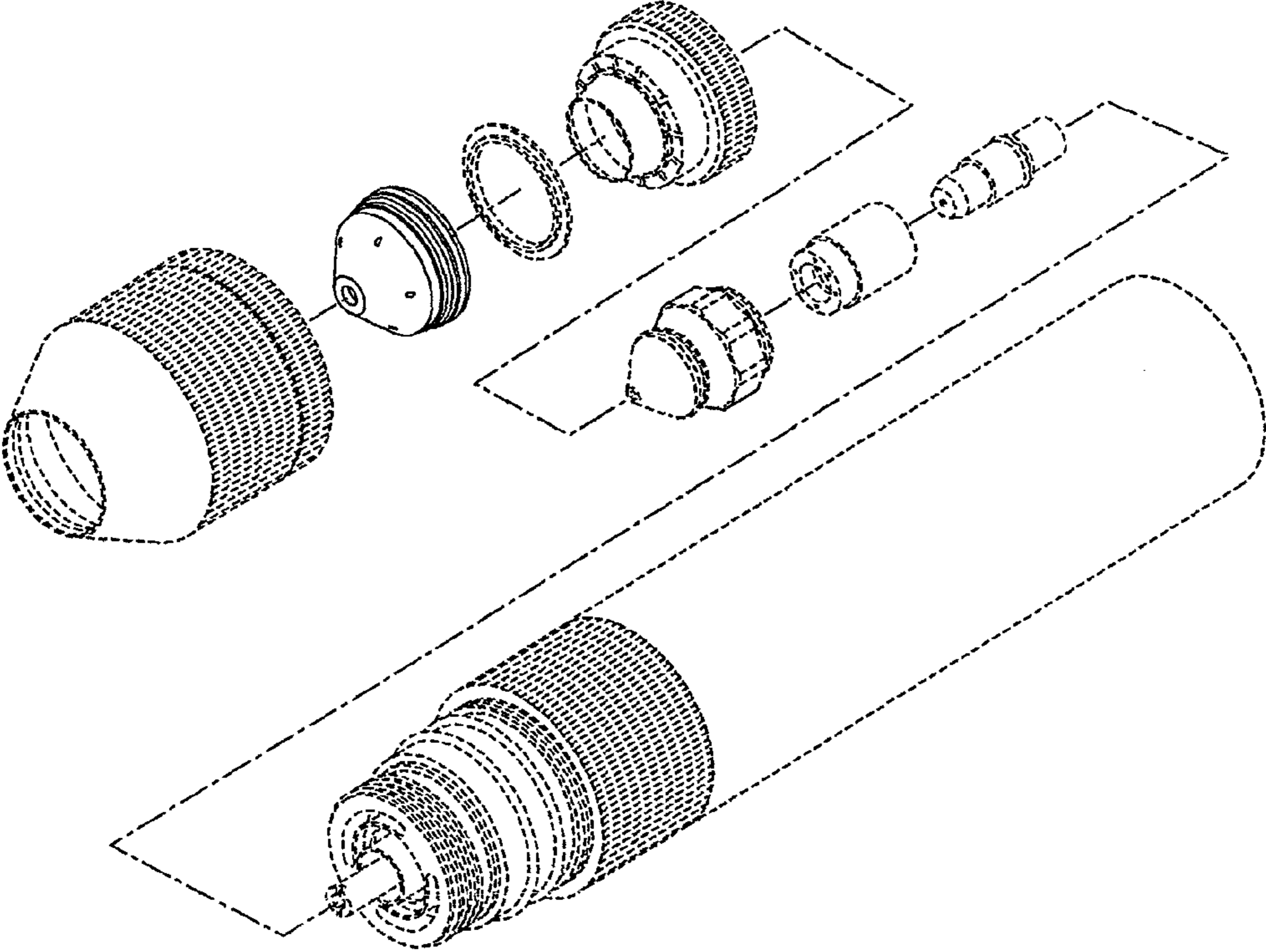

Fig. 10