



US00D701819S

(12) **United States Design Patent**
Cote et al.

(10) **Patent No.:** **US D701,819 S**

(45) **Date of Patent:** **** Apr. 1, 2014**

(54) **STRADDLE SEAT FOR A VEHICLE**

(75) Inventors: **Andre Cote**, Longueuil (CA); **Richard Lefebvre**, Shefford (CA); **Martin Lachance**, Granby (CA); **Sam Spade**, Palm Bay, FL (US); **Lonnie C. Lieb**, West Melbourne, FL (US)

(73) Assignee: **Bombardier Recreational Products Inc.**, Valcourt (CA)

(**) Term: **14 Years**

(21) Appl. No.: **29/394,375**

(22) Filed: **Jun. 16, 2011**

(51) **LOC (10) Cl.** **12-06**

(52) **U.S. Cl.**
USPC **D12/307; D12/317**

(58) **Field of Classification Search**
USPC D12/6-11, 119, 300-318; 114/55.5, 114/55.51-55.58, 345; D21/770; D6/354
See application file for complete search history.

(56) **References Cited**

U.S. PATENT DOCUMENTS

D359,469 S *	6/1995	Yoshida et al.	D12/307
D399,182 S *	10/1998	Lapointe et al.	D12/307
D463,771 S *	10/2002	Aselton et al.	D12/307
D464,015 S	10/2002	Bucaccio et al.	
D464,926 S *	10/2002	Mizuta et al.	D12/307
D465,190 S *	11/2002	Aselton et al.	D12/307
D465,193 S *	11/2002	Aselton et al.	D12/307
D468,117 S *	1/2003	Kalhok et al.	D6/354
D477,247 S *	7/2003	Cadotte et al.	D12/7
D479,602 S	9/2003	Bainton	
D485,527 S	1/2004	Cassell et al.	
D506,175 S *	6/2005	Bucaccio et al.	D12/307
D506,721 S *	6/2005	Cassell et al.	D12/307
D510,900 S	10/2005	Bucaccio et al.	
D516,006 S	2/2006	Bucaccio et al.	
D517,332 S *	3/2006	Manchester et al.	D6/354
D519,437 S *	4/2006	Bucaccio et al.	D12/307

D541,539 S *	5/2007	Basset et al.	D6/354
D549,472 S *	8/2007	Hanagan	D6/354
D550,603 S	9/2007	Cote et al.	
D581,685 S *	12/2008	Longpre et al.	D6/354
D603,319 S	11/2009	Cote et al.	
D608,719 S	1/2010	Cote et al.	
D632,632 S	2/2011	Cote	
D637,544 S	5/2011	Cote et al.	
D650,317 S *	12/2011	Yamamoto	D12/307
D657,168 S *	4/2012	Clarke-Smith	D6/354

* cited by examiner

Primary Examiner — Cynthia M Chin

(74) *Attorney, Agent, or Firm* — BRP LLP

(57) **CLAIM**

The ornamental design for a straddle seat for a vehicle, as shown and described.

DESCRIPTION

FIG. 1 is a perspective view taken from a front, right side of a straddle seat for a vehicle according to our design;

FIG. 2 is a rear elevation view thereof;

FIG. 3 is a front elevation view thereof;

FIG. 4 is a left side elevation view thereof;

FIG. 5 is a right side elevation view thereof;

FIG. 6 is a top plan view thereof;

FIG. 7 is a perspective view taken from a rear, left side thereof; and,

FIG. 8 is a perspective view taken from a rear, left side of the straddle seat for a vehicle of FIG. 1 shown on a personal watercraft shown in dotted lines.

Throughout the Figures, where shown: (i) the elements of the straddle seat for a vehicle shown in dotted lines are for illustrative purposes only and do not form part of the claimed design; and (ii) in FIGS. 1 to 8, the dotted/dashed lines represent unclaimed boundaries of the claimed design. Portions of the straddle seat for a vehicle not shown in the Figures and not otherwise described in this Specification do not form part of the claimed design.

1 Claim, 7 Drawing Sheets

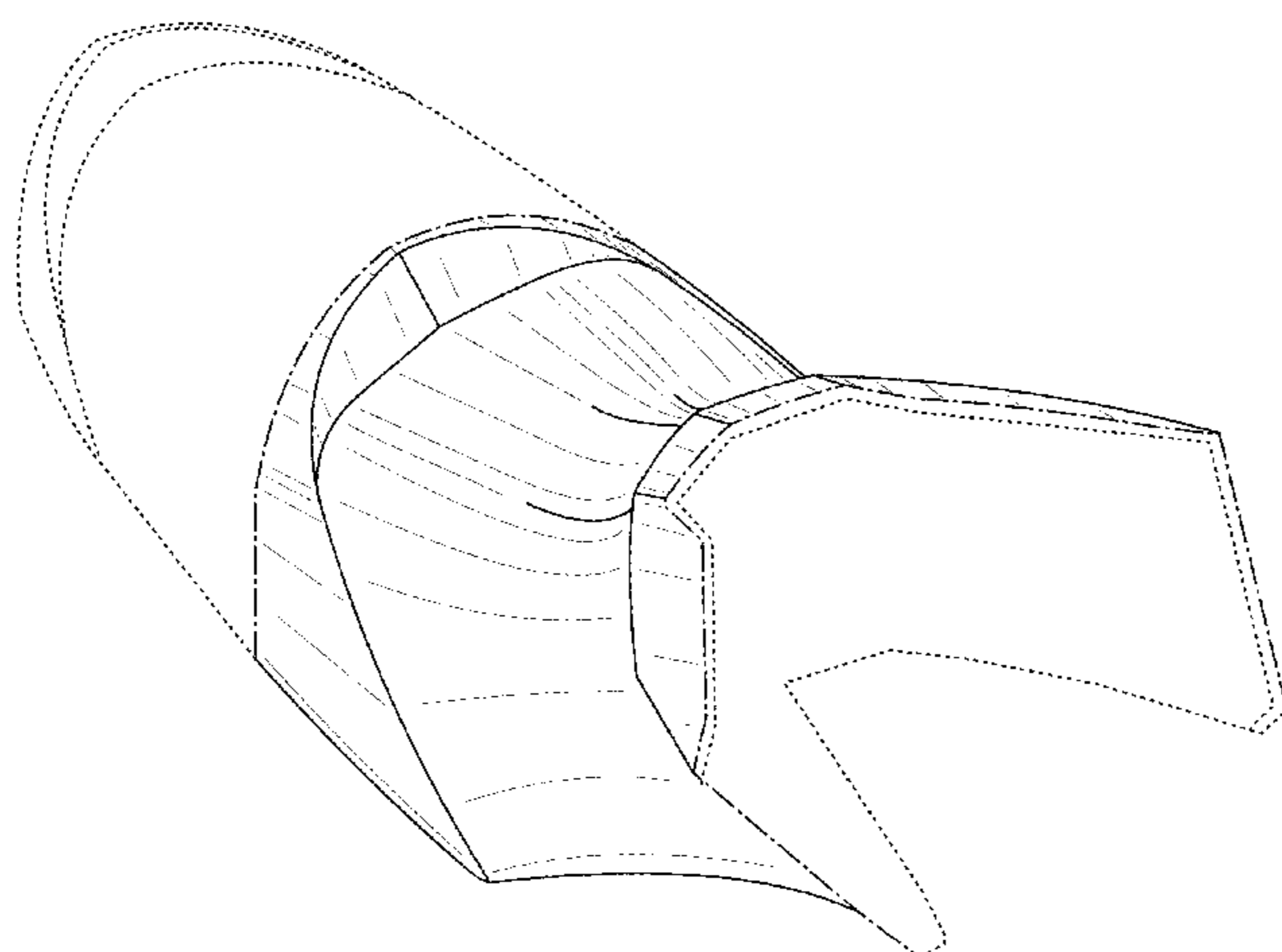

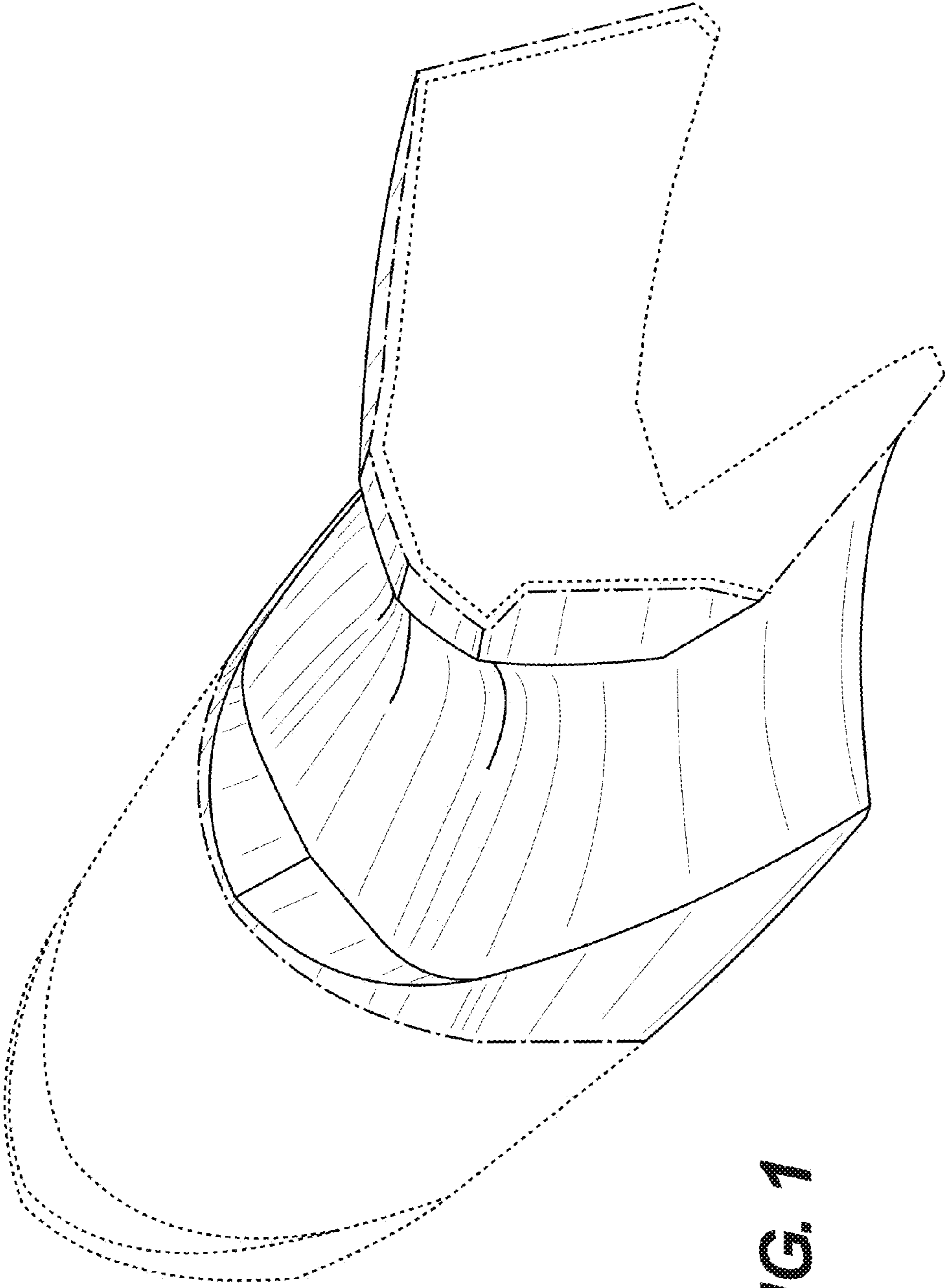

FIG. 1

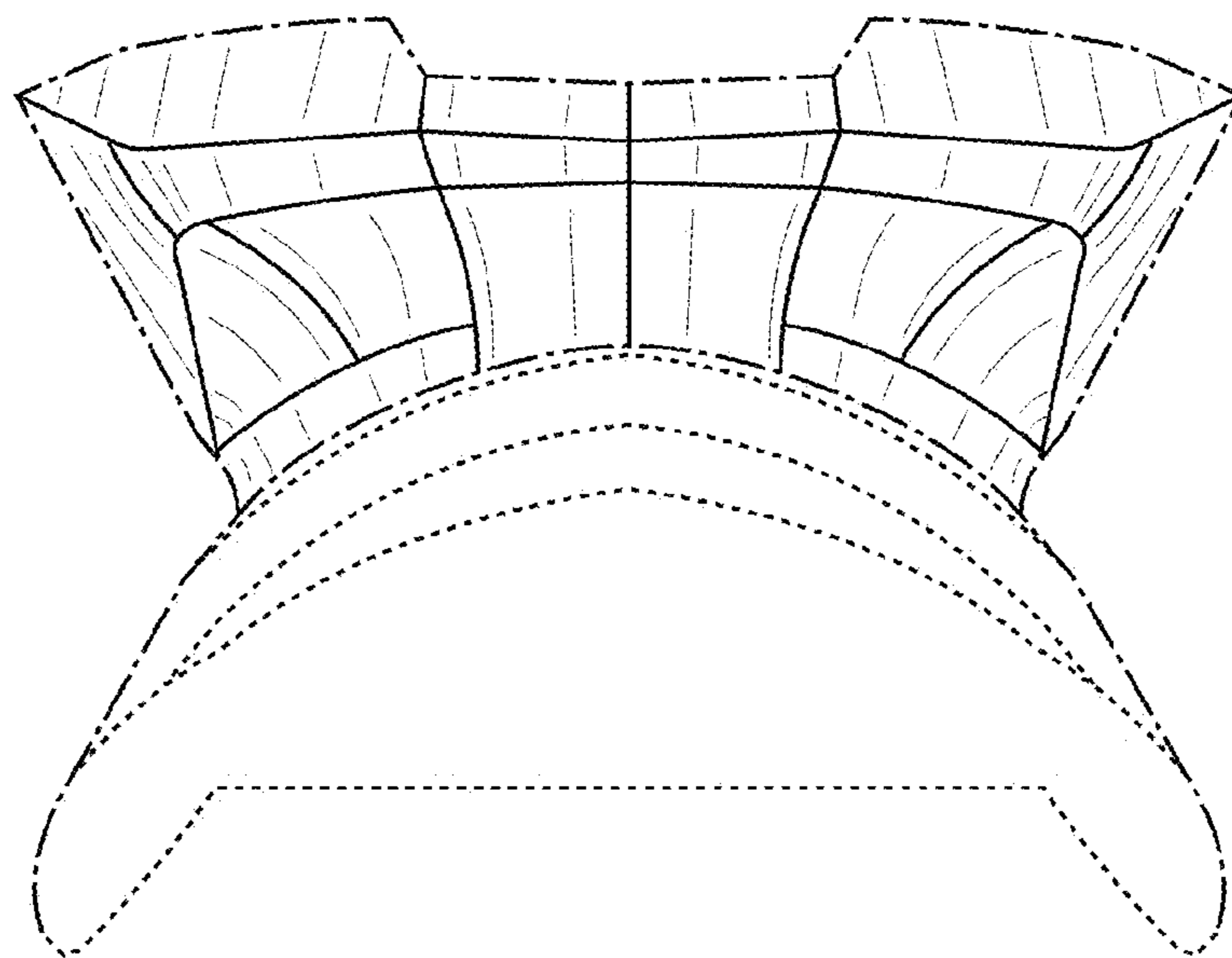

FIG. 2

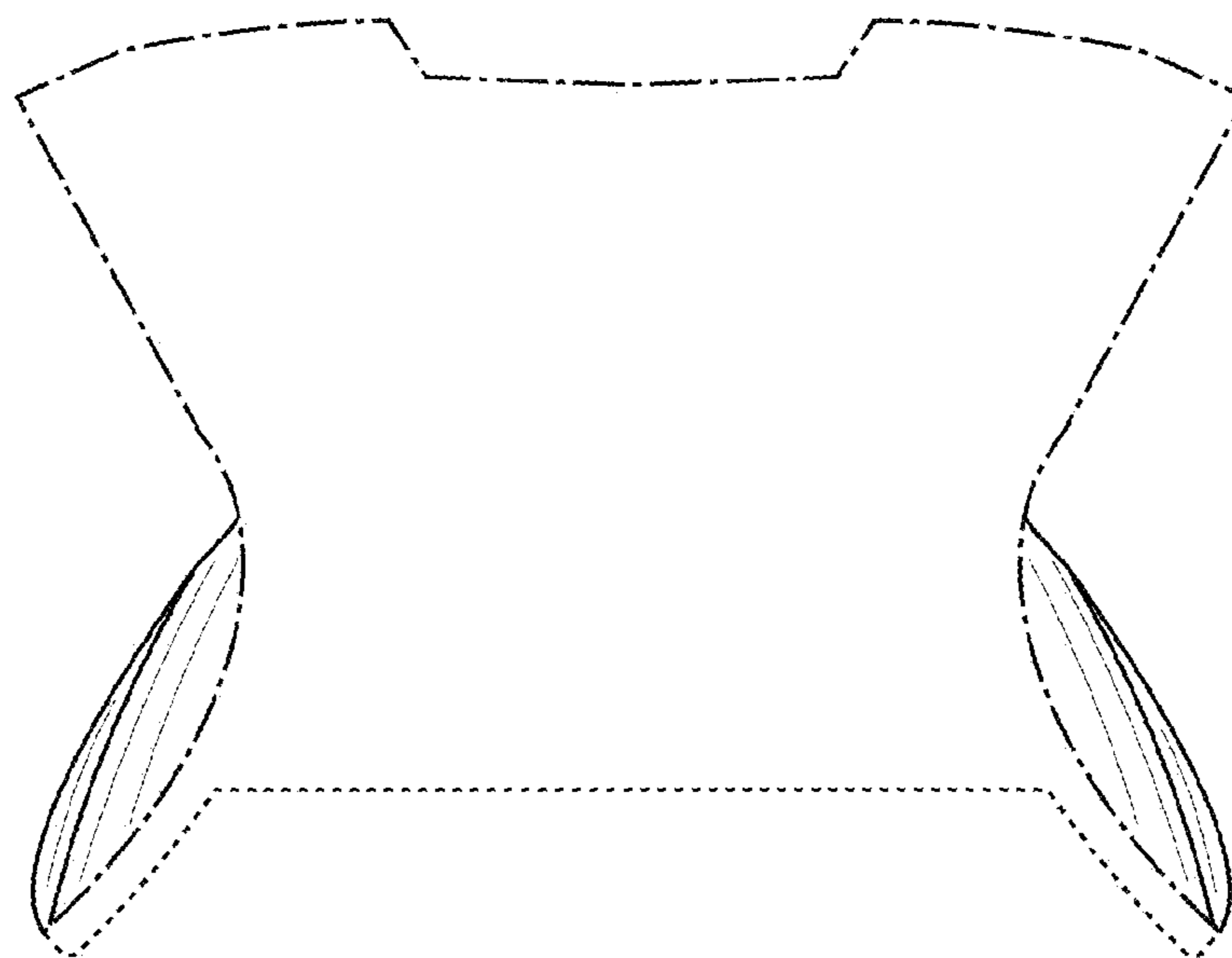

FIG. 3

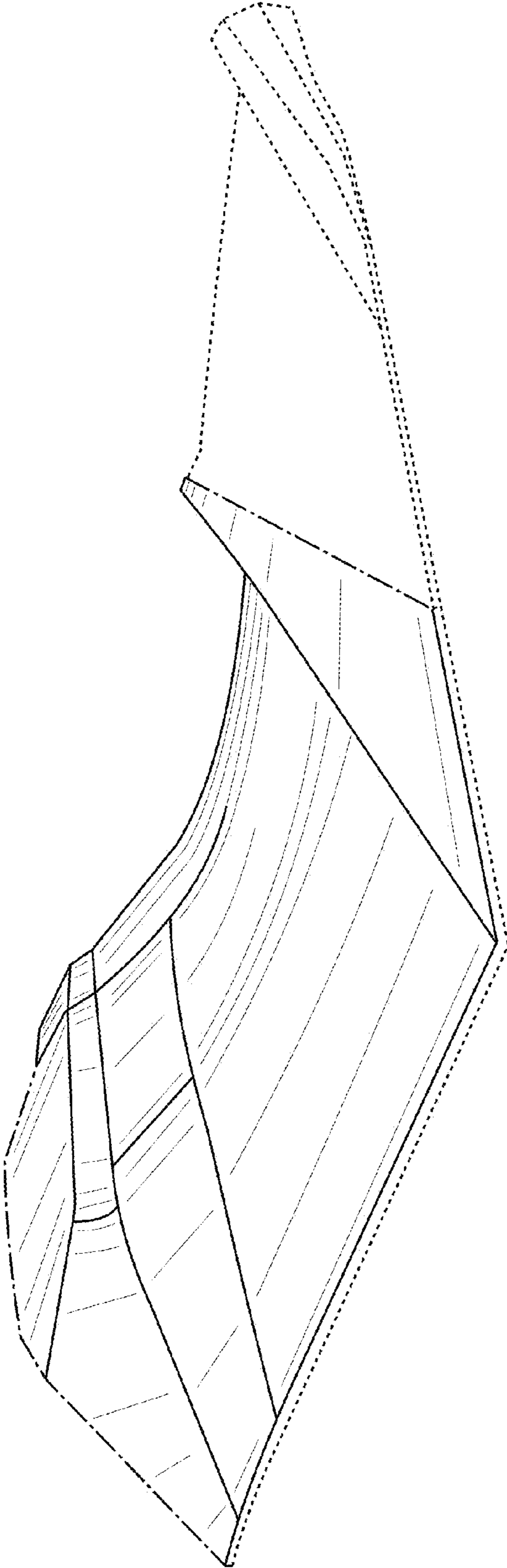

FIG. 4

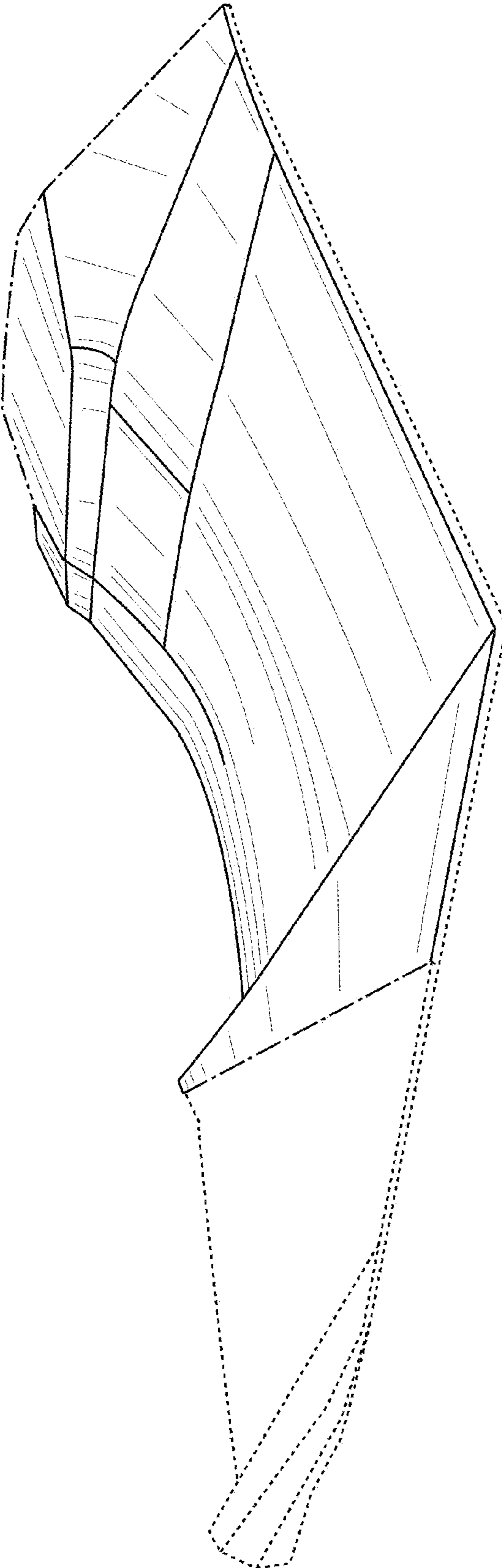

FIG. 5

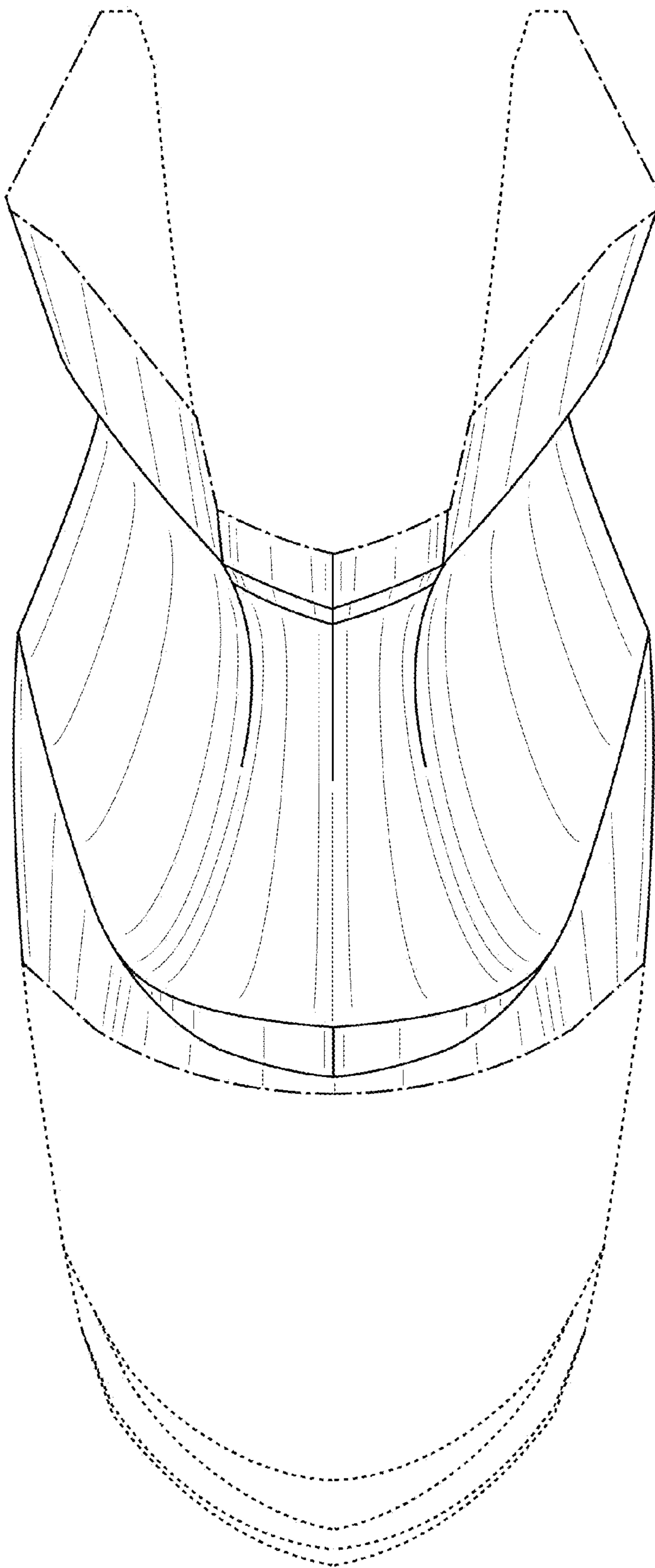

FIG. 6

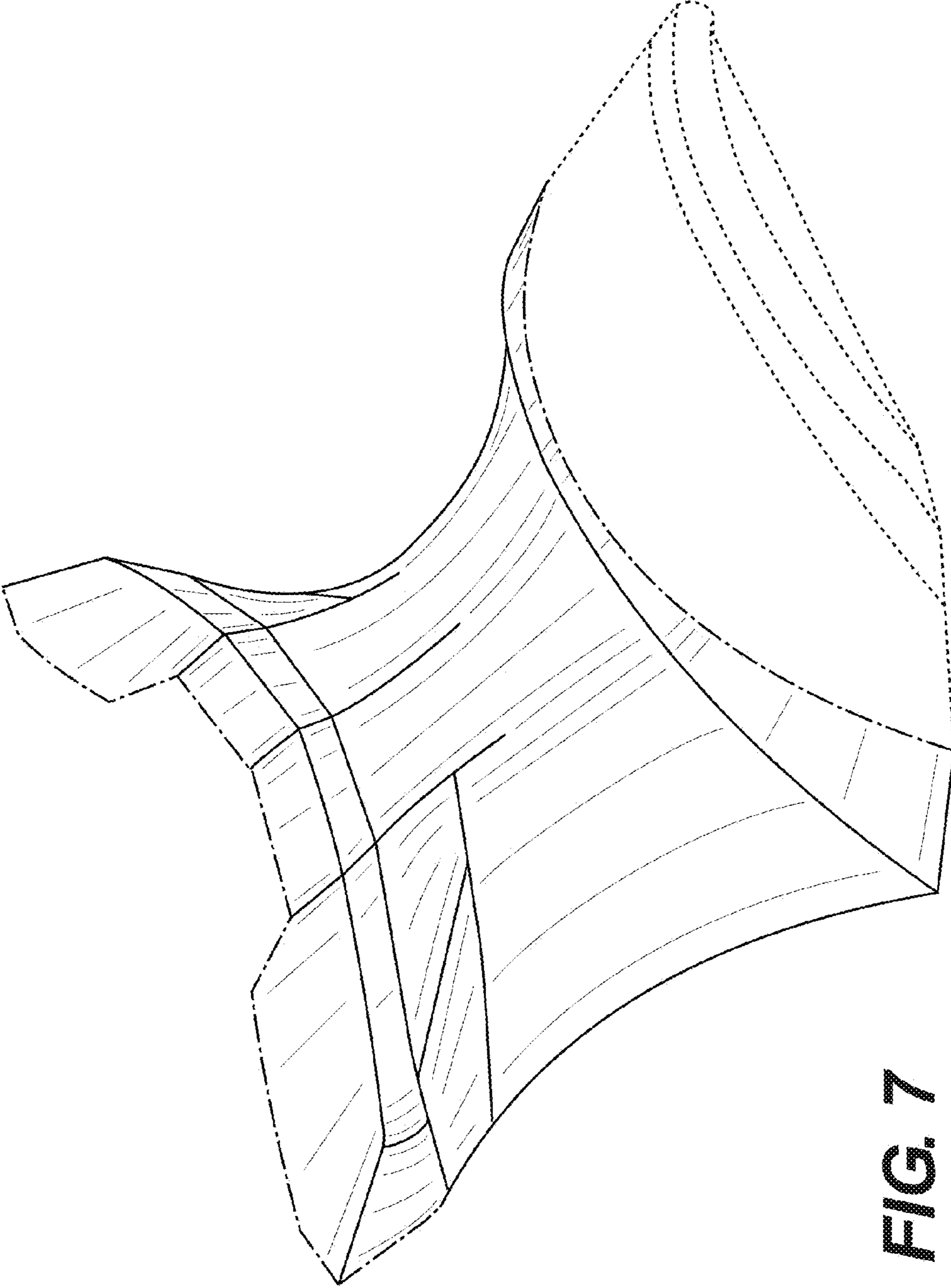

FIG. 7

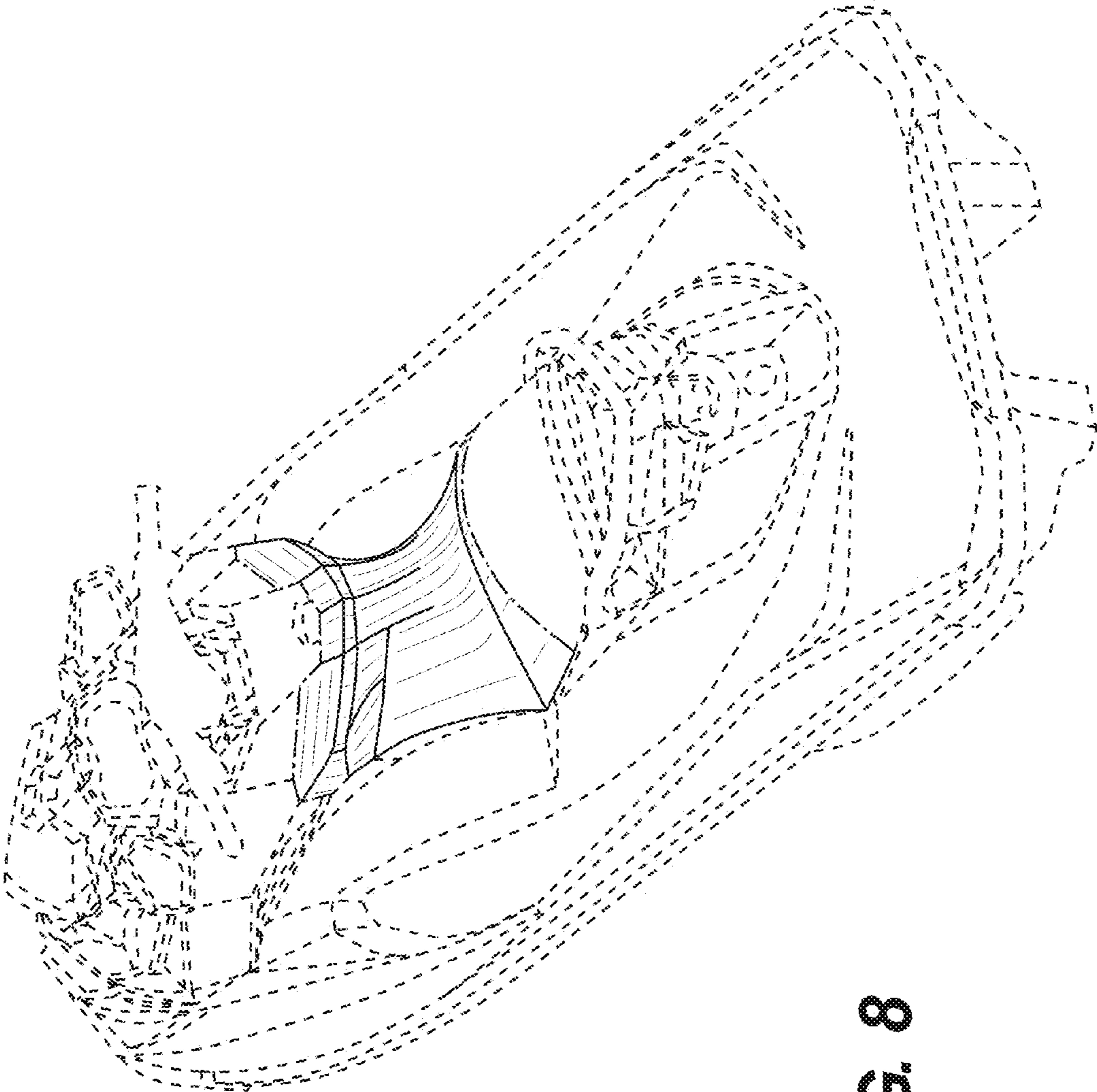

FIG. 8