



US00D701660S

(12) **United States Design Patent**  
**Sun**

(10) **Patent No.:** **US D701,660 S**  
(45) **Date of Patent:** **\*\* Mar. 25, 2014**

(54) **EXTERIOR SURFACE OF A CYCLONE RECEPTACLE**

(71) Applicant: **Electrolux Home Care Products, Inc.**,  
Charlotte, NC (US)

(72) Inventor: **Brian Wang Sun**, Shanghai (CN)

(73) Assignee: **Electrolux Home Care Products, Inc.**,  
Charlotte, NC (US)

(\*\*) Term: **14 Years**

(21) Appl. No.: **29/460,516**

(22) Filed: **Jul. 11, 2013**

**Related U.S. Application Data**

(62) Division of application No. 29/439,572, filed on Dec. 12, 2012, now Pat. No. Des. 689,658.

(51) **LOC (10) Cl.** ..... **15-05**

(52) **U.S. Cl.**  
USPC ..... **D32/31**

(58) **Field of Classification Search**  
USPC ..... D32/22, 30-31, 34, 19-20; 55/429,  
55/337, DIG. 3, 459.1, 345, 339, 426, 440,  
55/452-453, 456, 463; 15/410, 347, 328,  
15/350, 352, 353, 361, DIG. 8, 246.2,  
15/320-322, 409, 28, 23, 179, 97.1, 24;  
451/466; 210/512.1

See application file for complete search history.

(56) **References Cited**

**U.S. PATENT DOCUMENTS**

471,272 A 3/1892 Morse  
1,508,315 A 9/1924 Brockway  
1,565,318 A \* 12/1925 Fisher ..... 55/417  
2,010,128 A 8/1935 Arnold

2,378,600 A 6/1945 Tongeren  
2,432,757 A 12/1947 Weniger  
2,542,634 A 2/1951 Davis et al.  
2,698,672 A 1/1955 Burnside et al.  
3,234,713 A 2/1966 Harper et al.  
3,320,727 A 5/1967 Farley et al.  
3,399,770 A 9/1968 Salomon  
3,543,325 A 12/1970 Hamrick  
3,745,965 A 7/1973 Ljung et al.  
3,887,456 A 6/1975 Loughner  
3,971,718 A 7/1976 Reid

(Continued)

*Primary Examiner* — Ruth McInroy

(74) *Attorney, Agent, or Firm* — RatnerPrestia

(57) **CLAIM**

The ornamental design for an exterior surface of a cyclone receptacle, as shown and described.

**DESCRIPTION**

FIG. 1 is a perspective view of an exterior surface of a cyclone receptacle showing my new design;  
FIG. 2 is a front elevation view thereof;  
FIG. 3 is a left side elevation view thereof;  
FIG. 4 is a rear elevation view thereof;  
FIG. 5 is a right side elevation view thereof;  
FIG. 6 is a top plan view thereof;  
FIG. 7 is a bottom plan view thereof;  
FIG. 8 is a perspective view of a second embodiment thereof;  
FIG. 9 is a front elevation view of FIG. 8;  
FIG. 10 is a left side elevation view of FIG. 8;  
FIG. 11 is a rear elevation view of FIG. 8;  
FIG. 12 is a right side elevation view of FIG. 8;  
FIG. 13 is a top plan view of FIG. 8; and,  
FIG. 14 is a bottom plan view of FIG. 8.

The broken lines which define the bounds of the claim or environmental structure form no part of the claimed design.

**1 Claim, 14 Drawing Sheets**

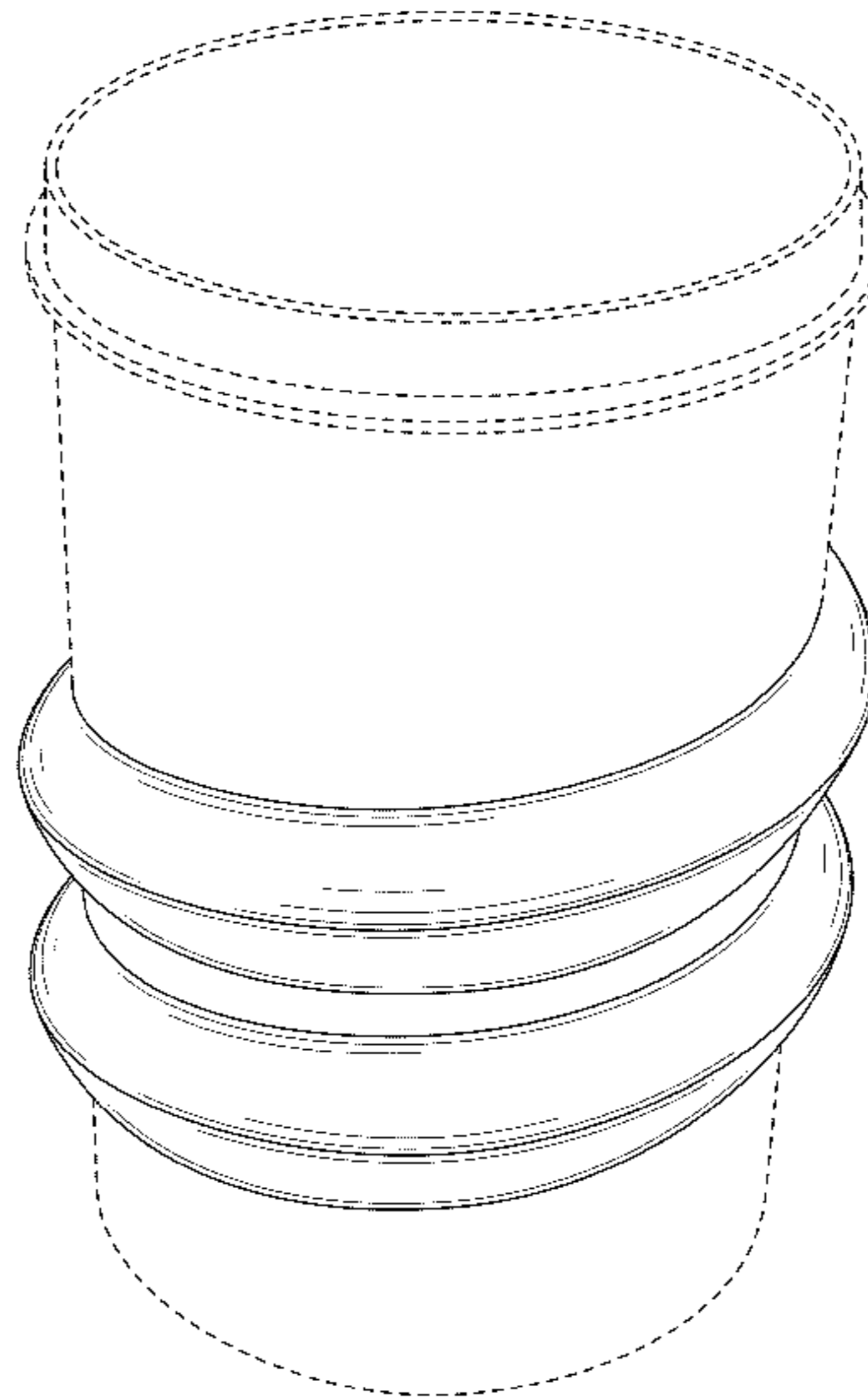
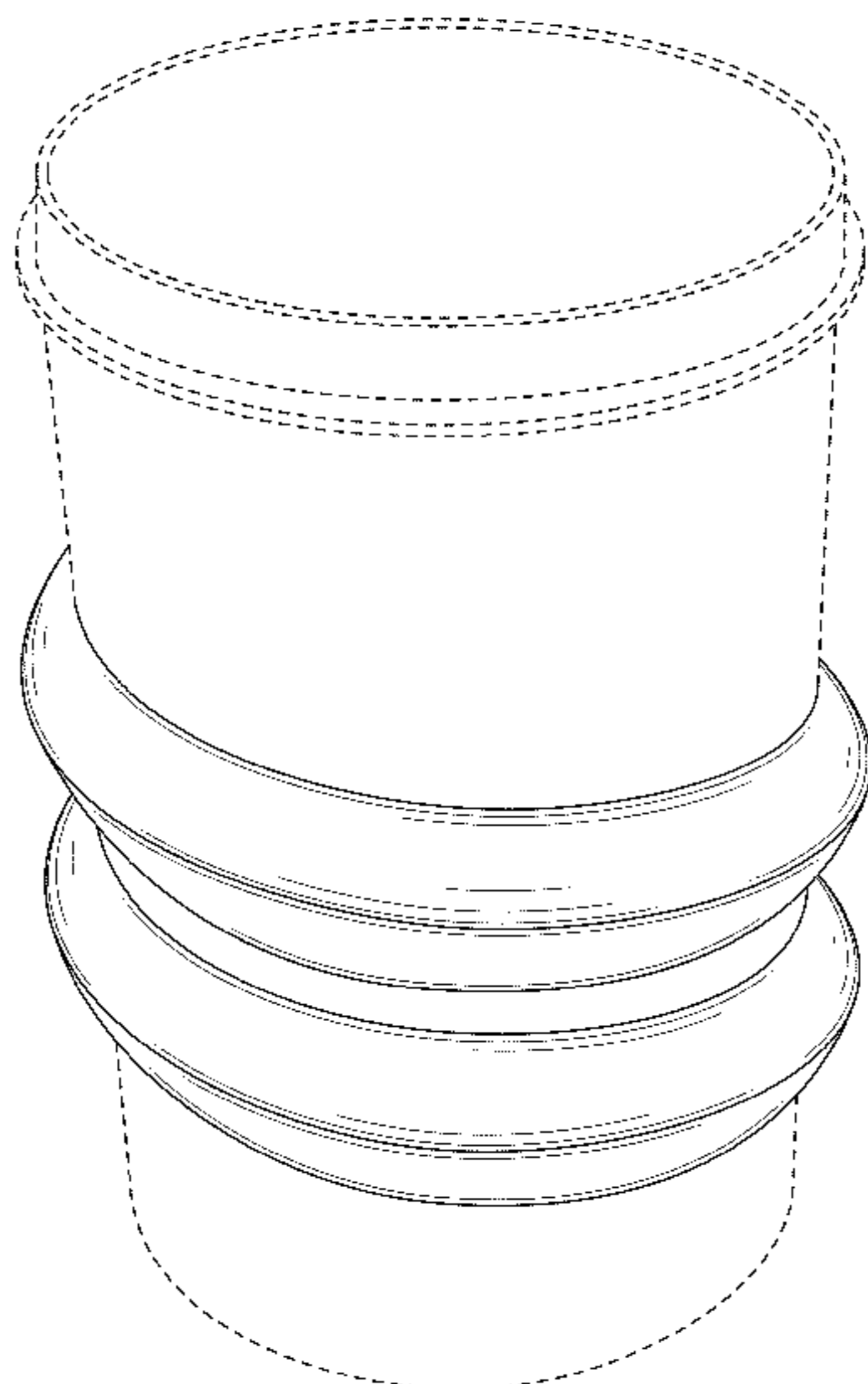

(56)

References Cited

U.S. PATENT DOCUMENTS

4,059,419	A	11/1977	Ross				
4,062,766	A	12/1977	Duesling				
4,510,056	A	4/1985	Frykhult et al.				
4,537,314	A	8/1985	Skardal				
4,853,008	A	8/1989	Dyson				
4,953,253	A	9/1990	Fukuda et al.				
5,078,761	A	1/1992	Dyson				
5,137,554	A	8/1992	Carter, Jr.				
5,145,499	A	9/1992	Dyson				
5,224,976	A *	7/1993	Oranje	55/399			
5,281,591	A	1/1994	Burke				
5,653,347	A	8/1997	Larsson				
5,846,273	A	12/1998	Dyson				
D407,875	S *	4/1999	Burchard et al.	D32/31			
5,893,936	A	4/1999	Dyson				
6,129,775	A	10/2000	Conrad et al.				
6,146,434	A	11/2000	Scalfani et al.				
6,168,641	B1	1/2001	Tuvin et al.				
6,168,716	B1	1/2001	Conrad et al.				
6,312,594	B1	11/2001	Conrad et al.				
6,363,574	B2	4/2002	Worden et al.				
6,502,277	B1	1/2003	Petersson et al.				
6,558,453	B2	5/2003	Sepke et al.				
D494,718	S *	8/2004	Rosenzweig et al.	D32/31			
D494,719	S *	8/2004	Rosenzweig et al.	D32/31			
6,829,804	B2	12/2004	Sepke				
6,910,245	B2	6/2005	Hawkins et al.				
D518,612	S *	4/2006	Parr et al.	D32/31			
D520,692	S *	5/2006	Leyden	D32/31			
7,163,568	B2	1/2007	Sepke et al.				
7,222,392	B2	5/2007	McCormick et al.				
7,228,592	B2	6/2007	Hawkins et al.				
D547,507	S *	7/2007	Medema et al.	D32/31			
7,247,181	B2	7/2007	Hansen et al.				
7,293,326	B2	11/2007	Hawkins et al.				
7,305,735	B2 *	12/2007	Overvaag	15/352			
D581,612	S *	11/2008	Yoo et al.	D32/31			
D583,117	S *	12/2008	Peace et al.	D32/31			
D587,415	S *	2/2009	Dyson et al.	D32/31			
D589,219	S *	3/2009	Knox et al.	D32/31			
7,594,945	B2 *	9/2009	Kim et al.	55/429			
D609,416	S *	2/2010	Hill et al.	D32/31			
D609,418	S *	2/2010	Santiago et al.	D32/31			
7,662,200	B2	2/2010	Knuth et al.				
7,682,414	B2 *	3/2010	Yoshida et al.	55/429			
7,722,709	B2	5/2010	Conrad				
7,771,499	B2 *	8/2010	Oh et al.	55/343			
7,814,612	B2	10/2010	Sepke et al.				
D632,037	S *	2/2011	Carr et al.	D32/31			
7,879,142	B2 *	2/2011	Han et al.	96/381			
7,922,794	B2	4/2011	Morphey				
7,931,740	B2	4/2011	Al-Alusi et al.				
7,951,214	B2	5/2011	Menrik et al.				
8,225,456	B2	7/2012	HåKan et al.				
D670,052	S *	10/2012	Dos Reis	D32/31			
2002/0144637	A1	10/2002	Wendling et al.				
2007/0012003	A1 *	1/2007	Oh et al.	55/429			
2008/0184681	A1 *	8/2008	Oh et al.	55/345			

\* cited by examiner

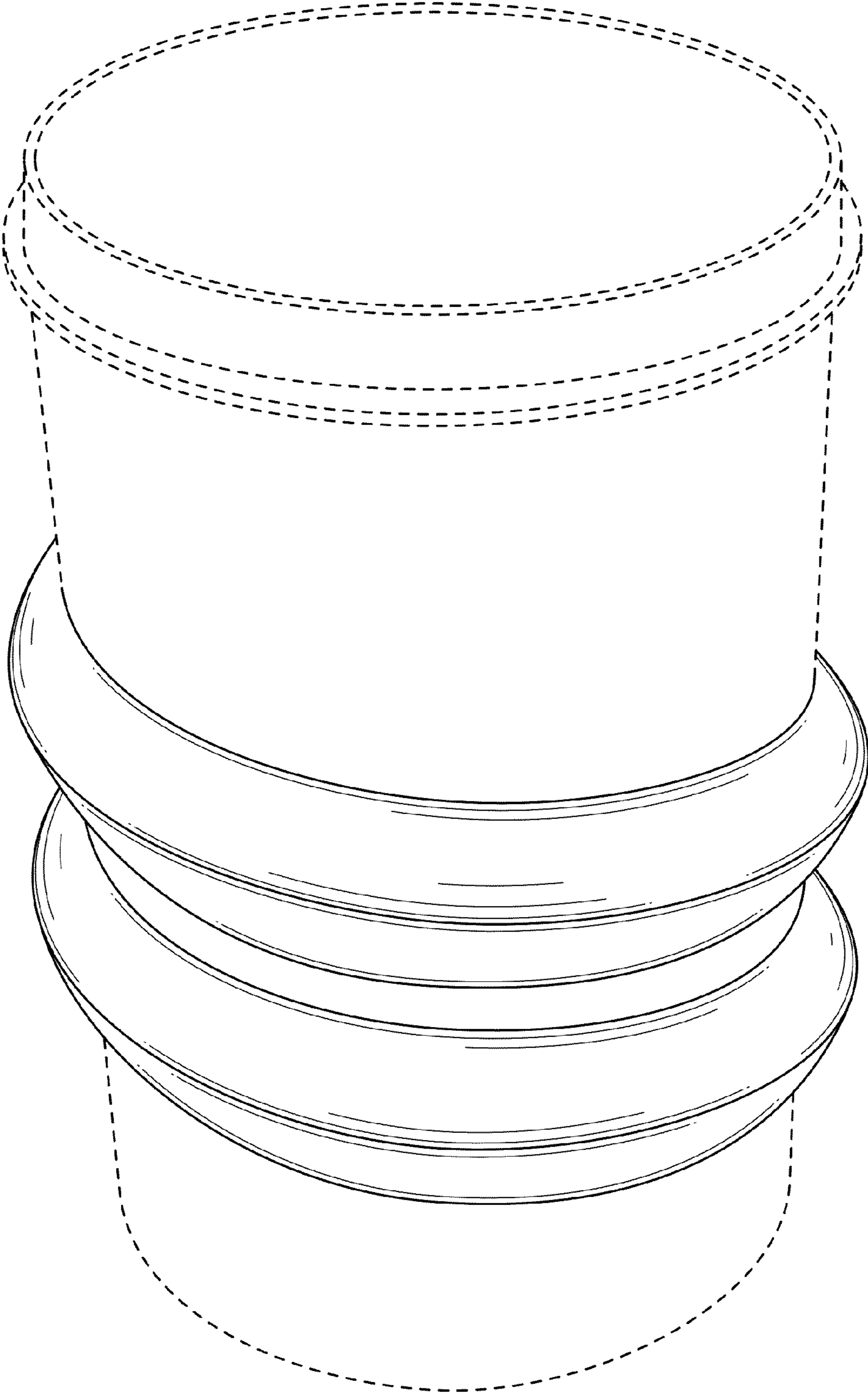

FIG. 1

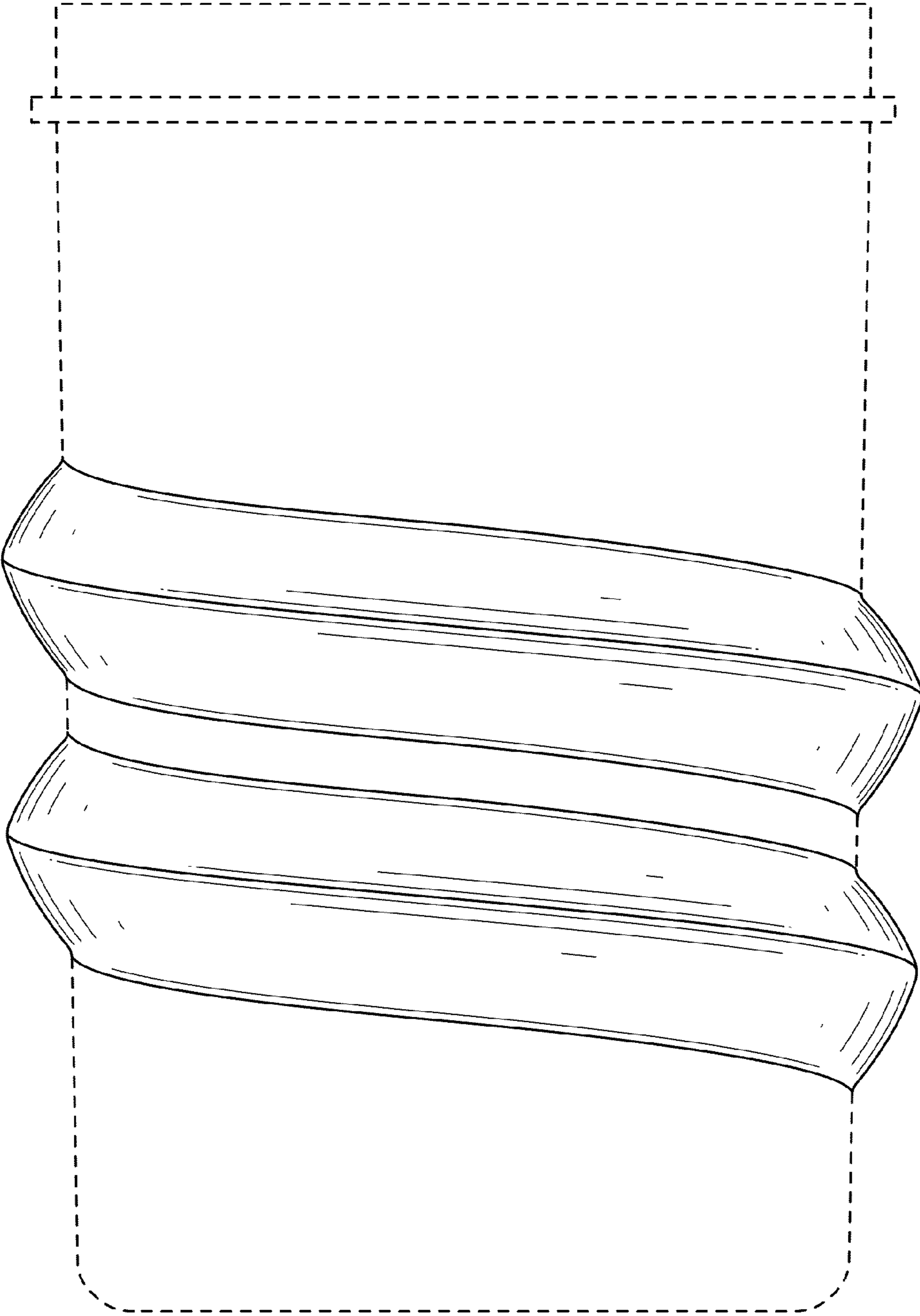

FIG. 2

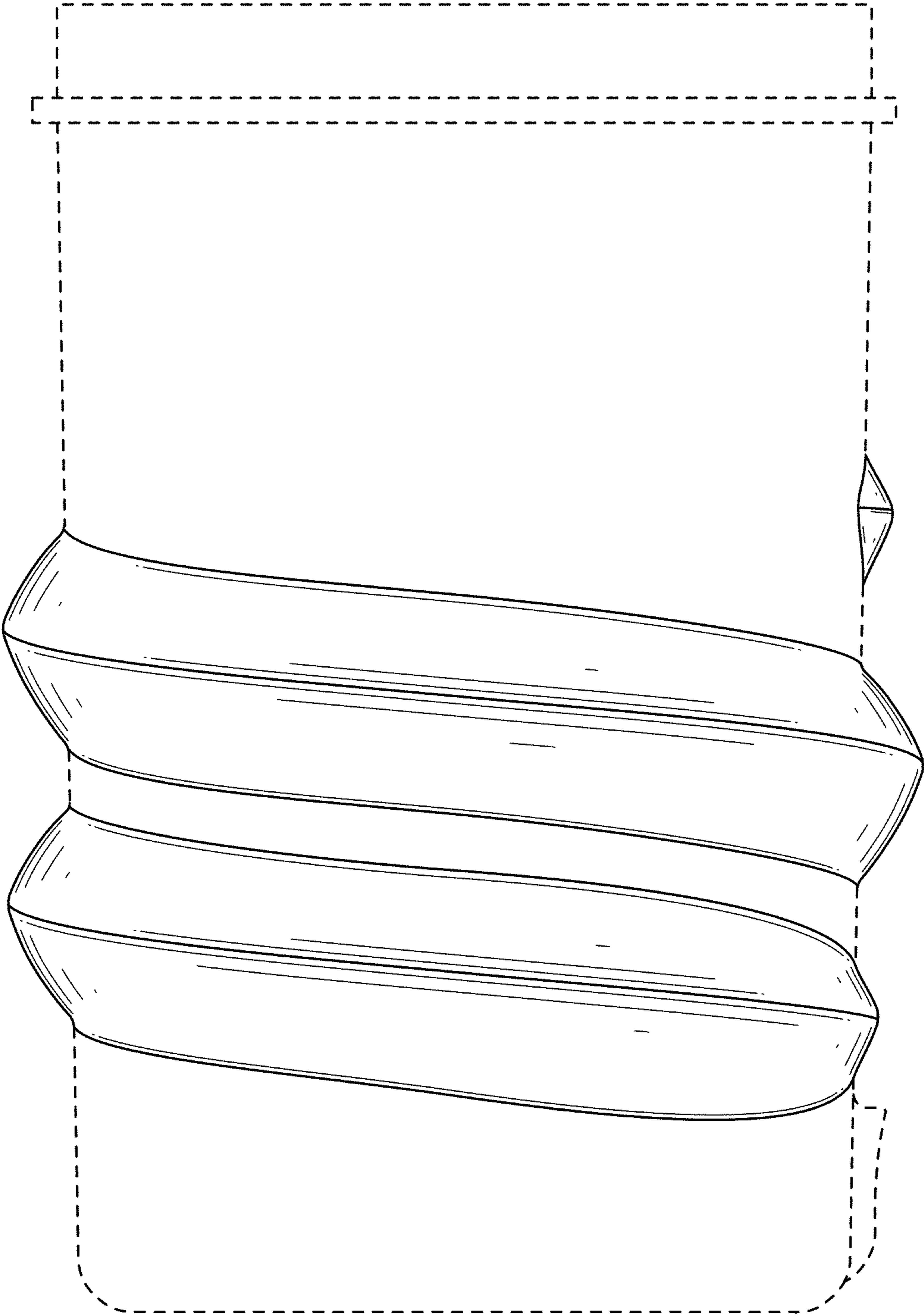

FIG. 3

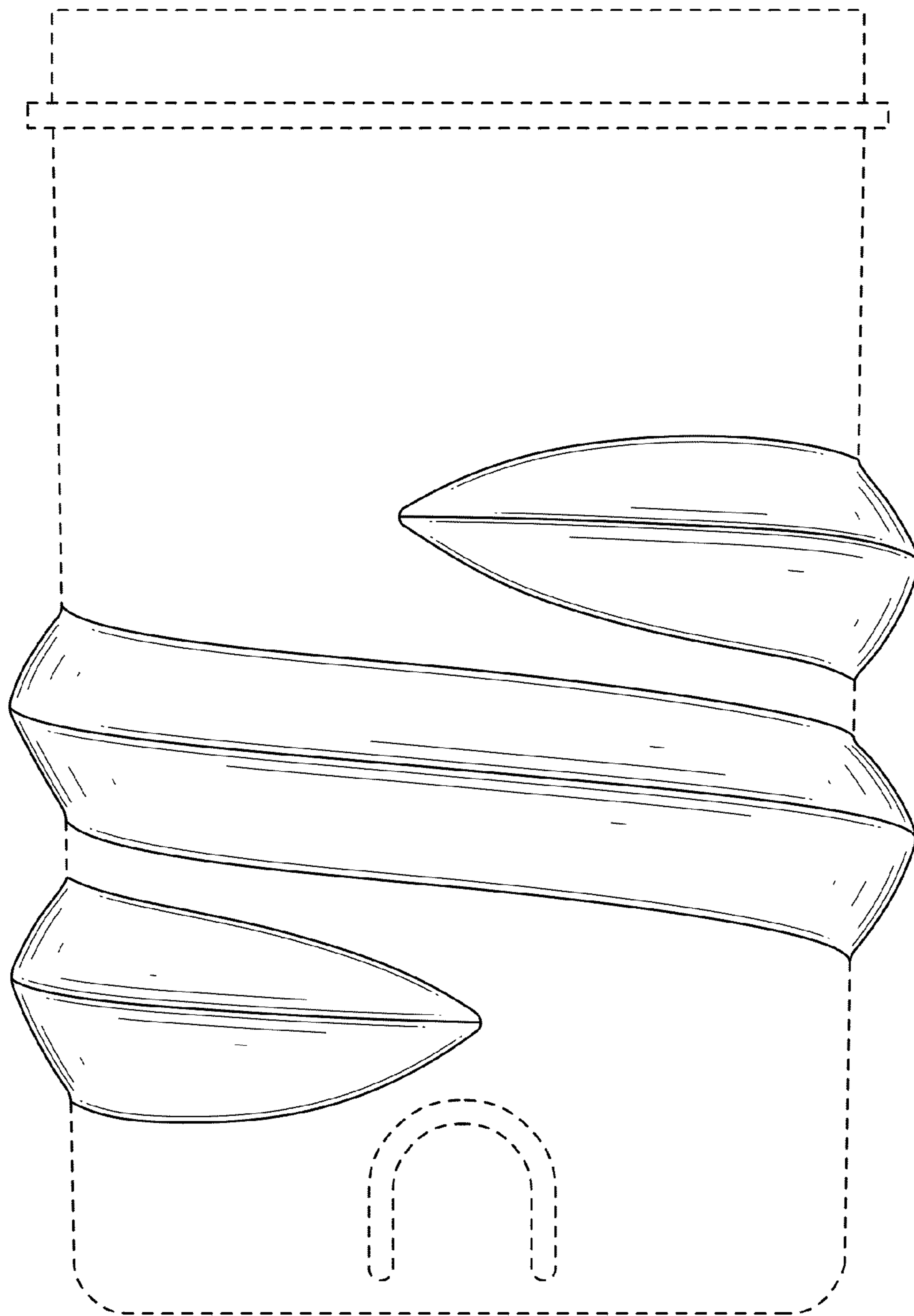

FIG. 4

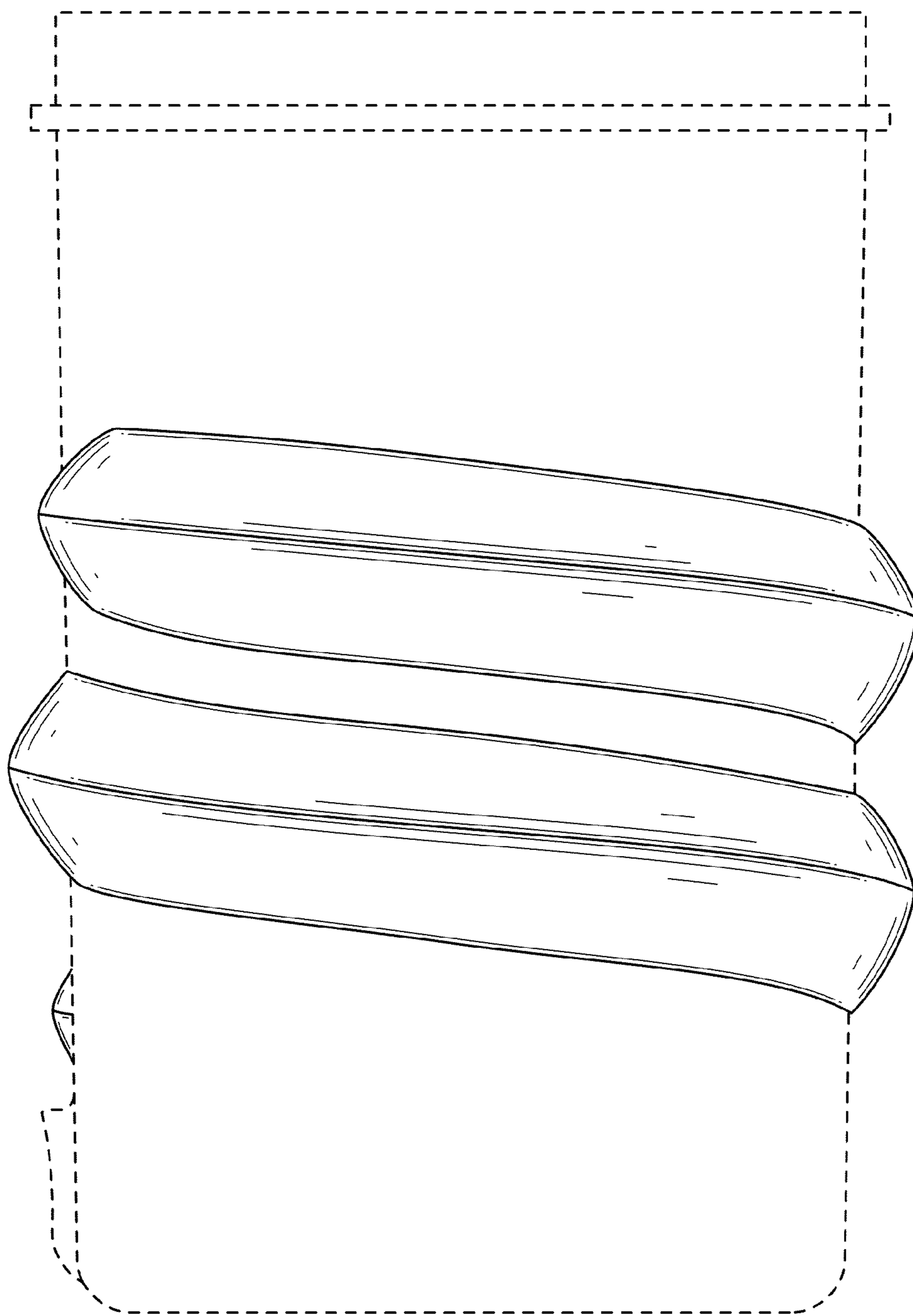

FIG. 5

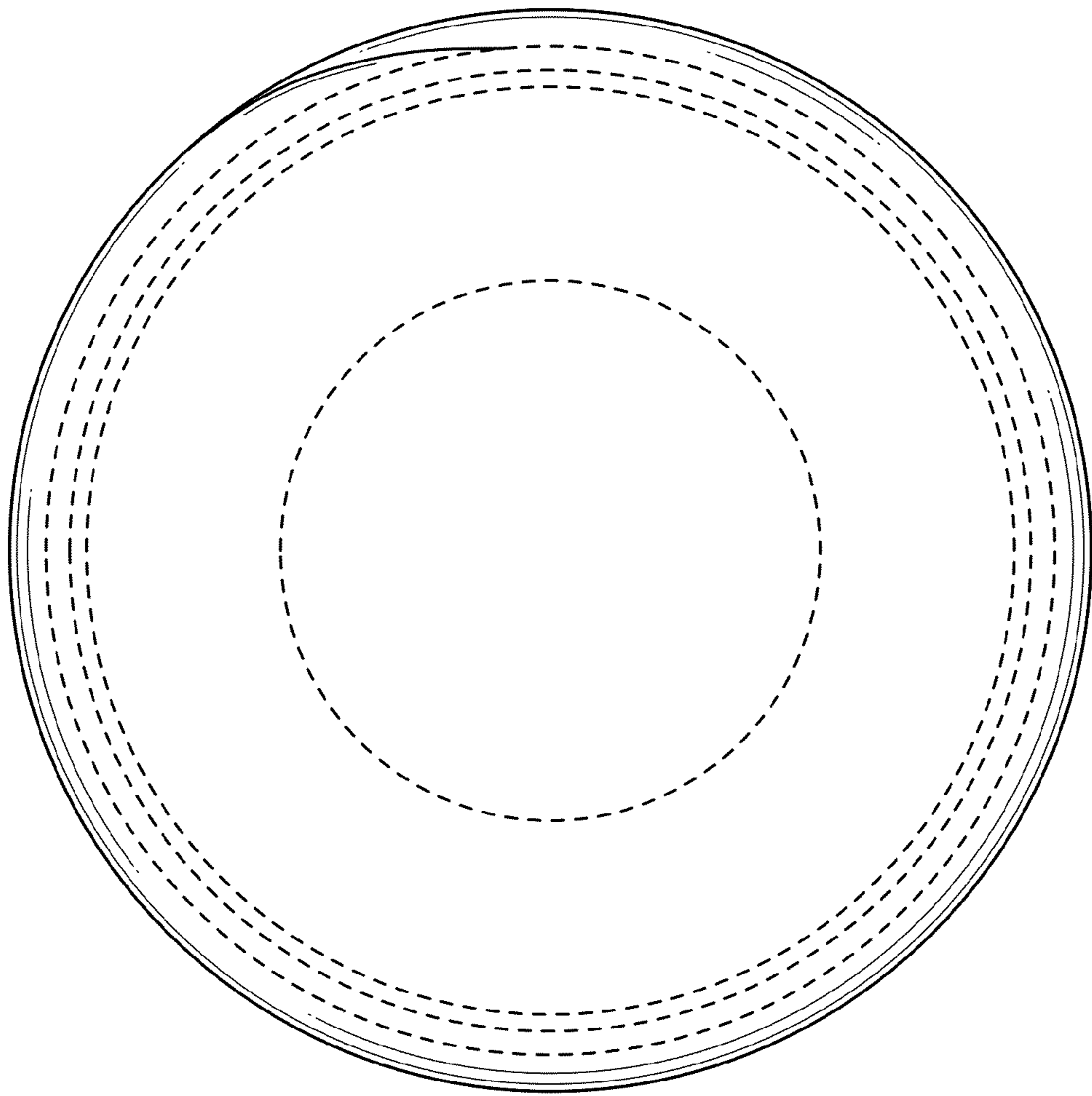

FIG. 6



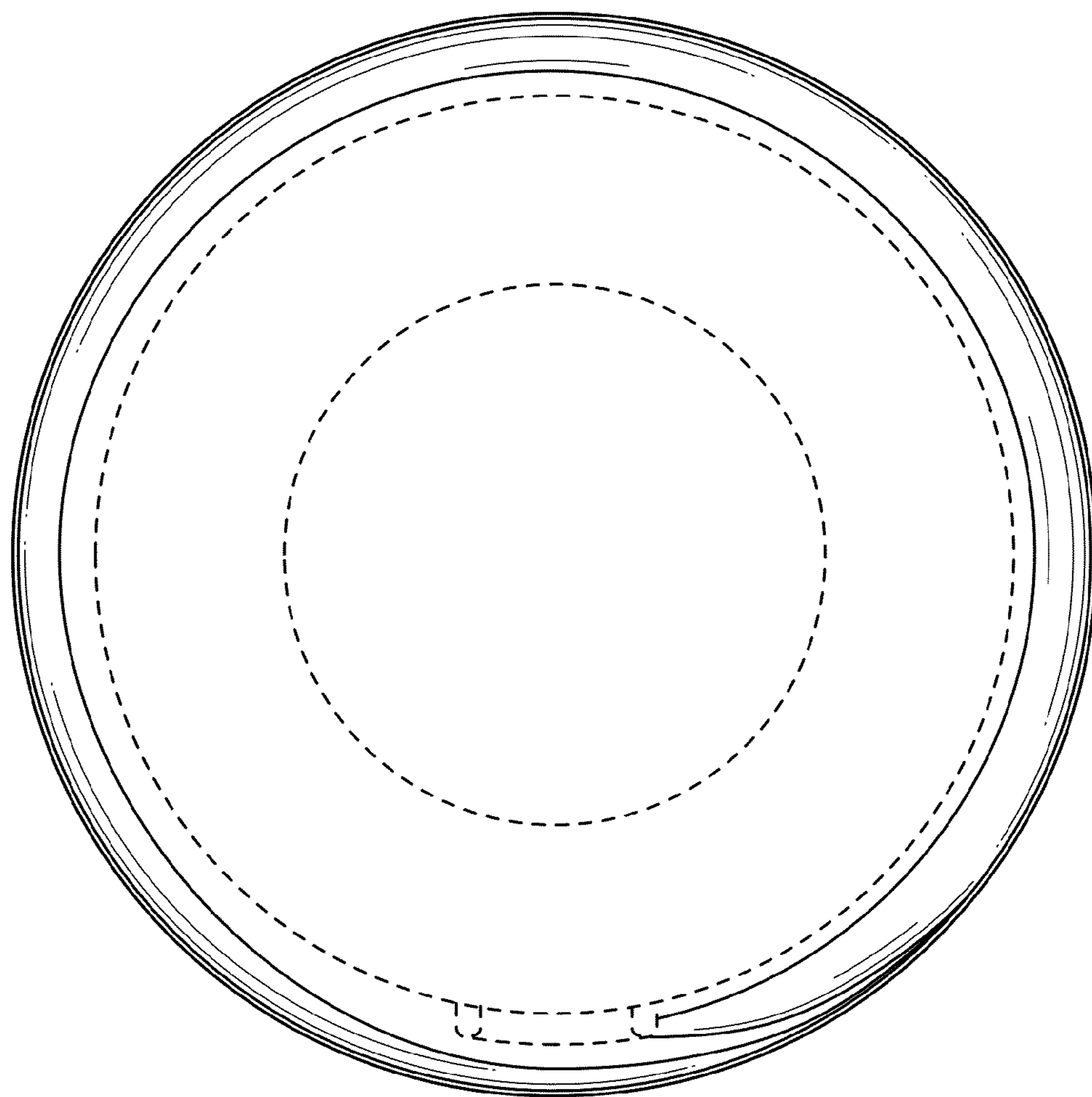

FIG. 7

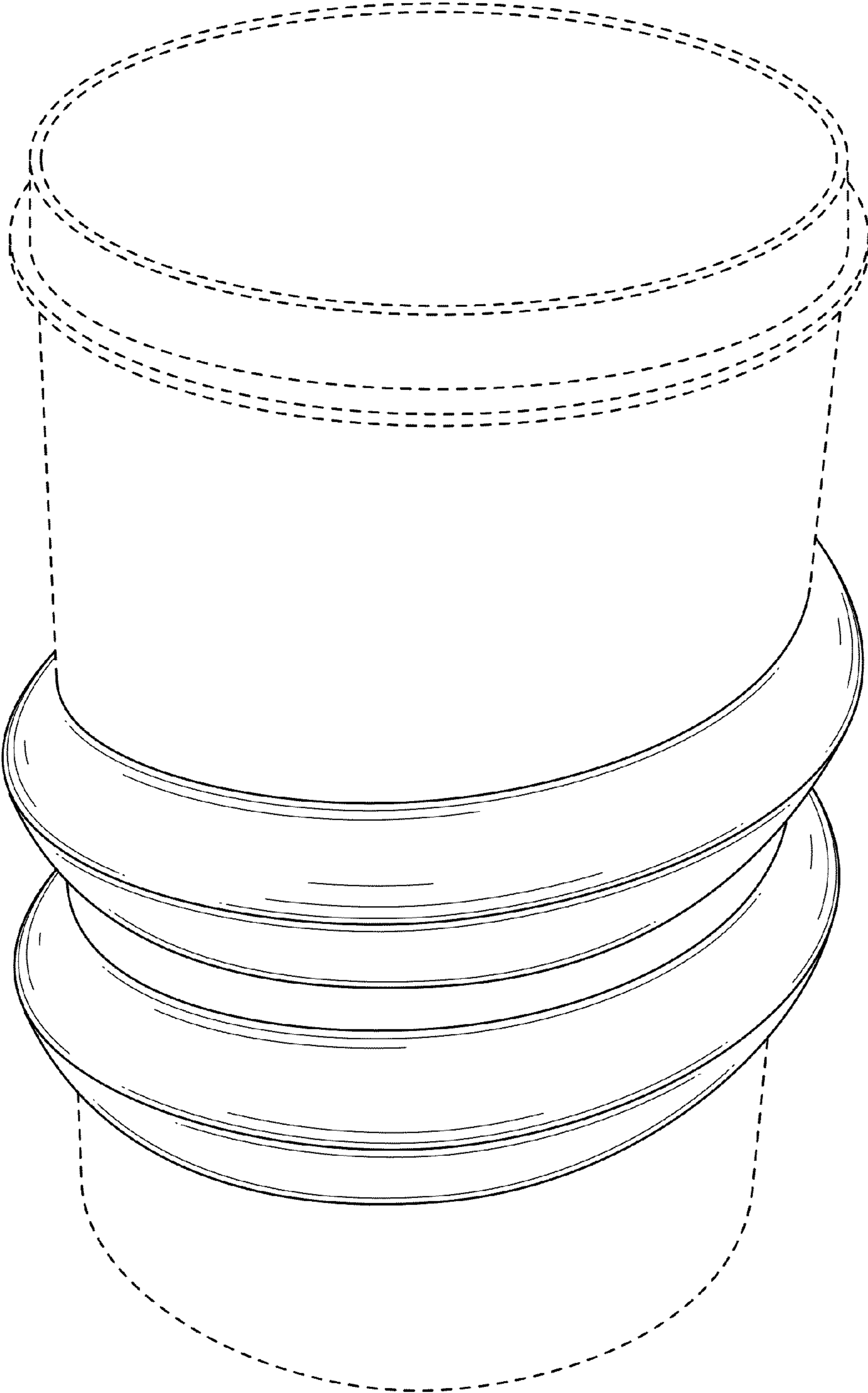

FIG. 8

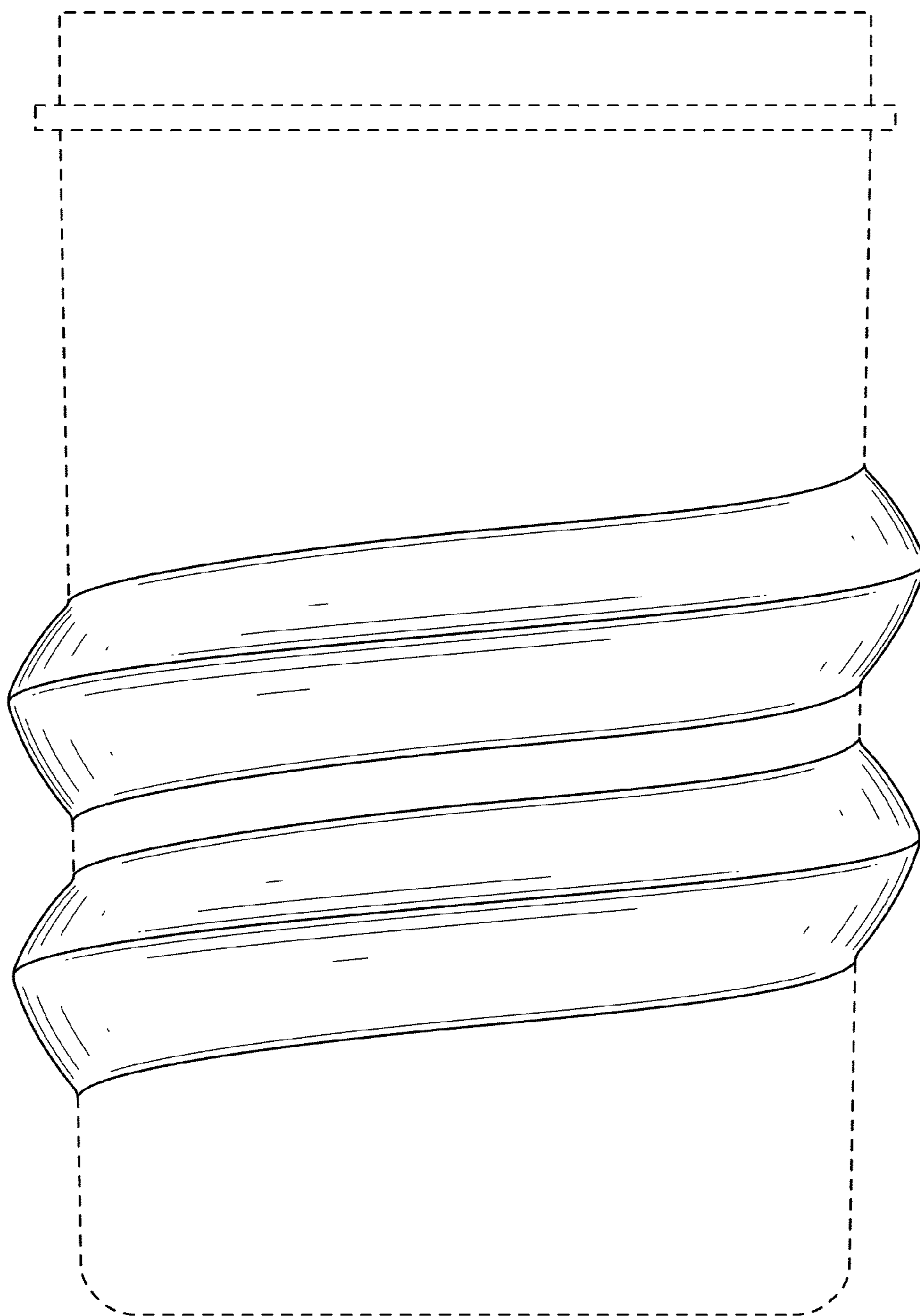

FIG. 9

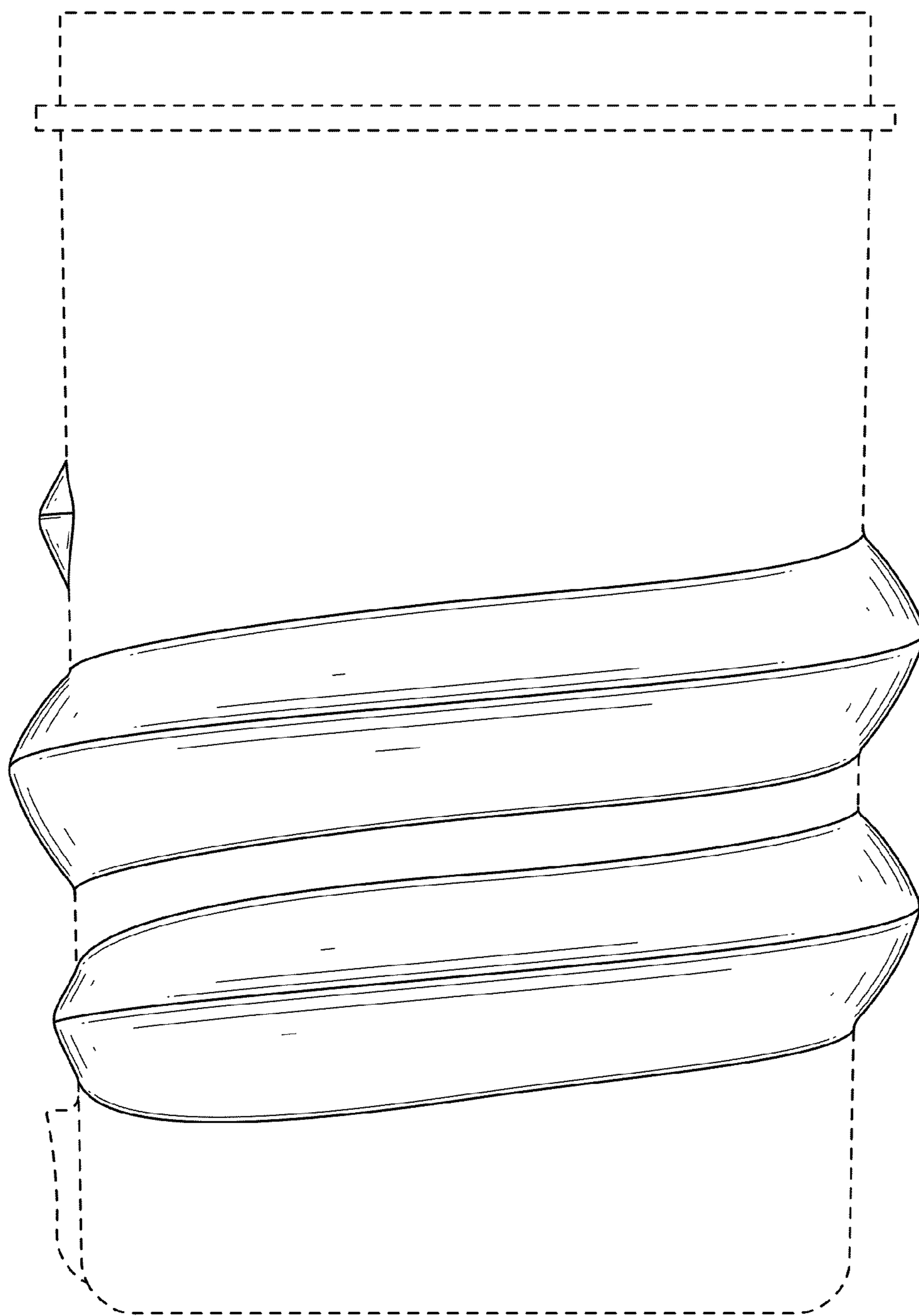

FIG. 10

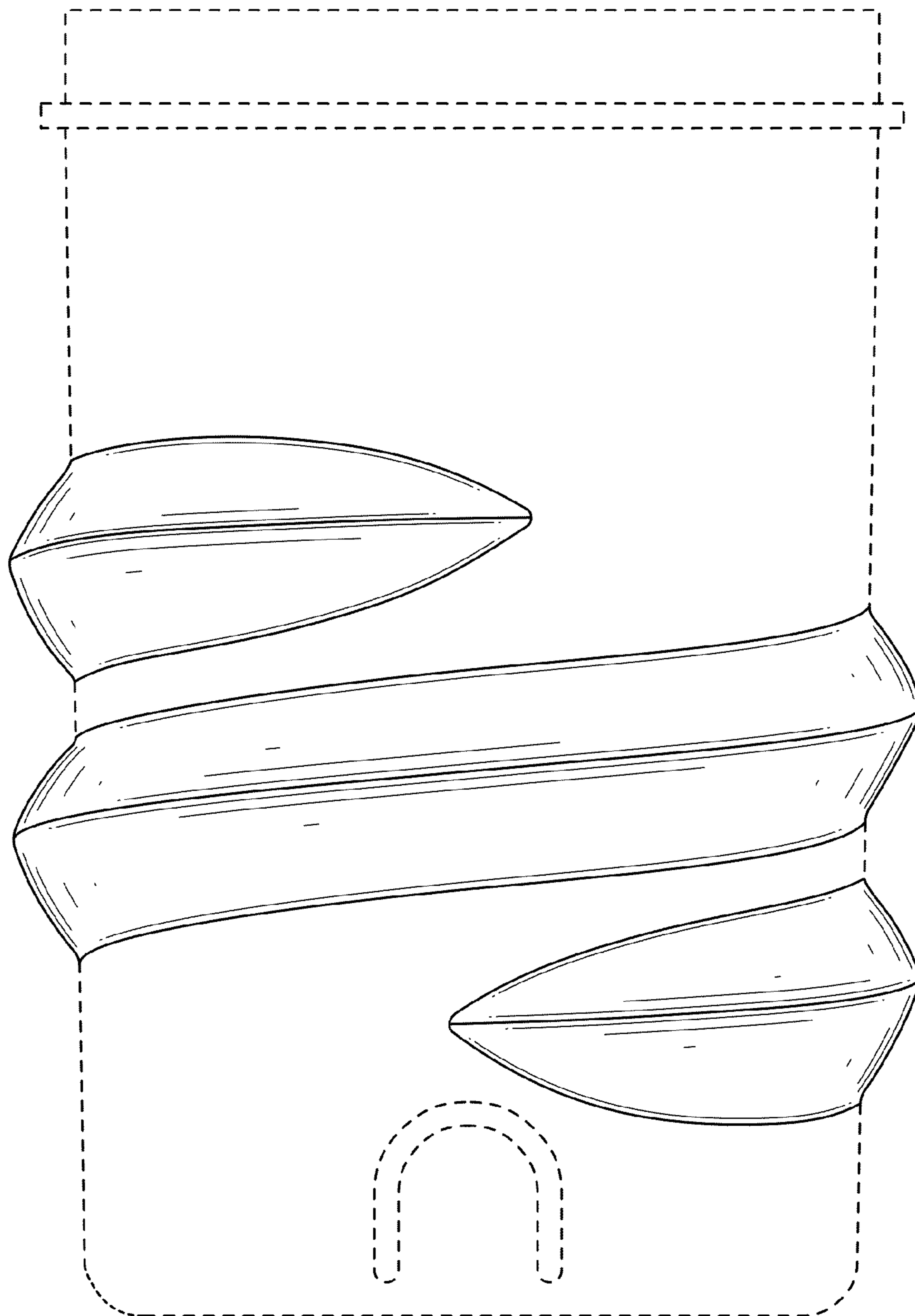

FIG. 11

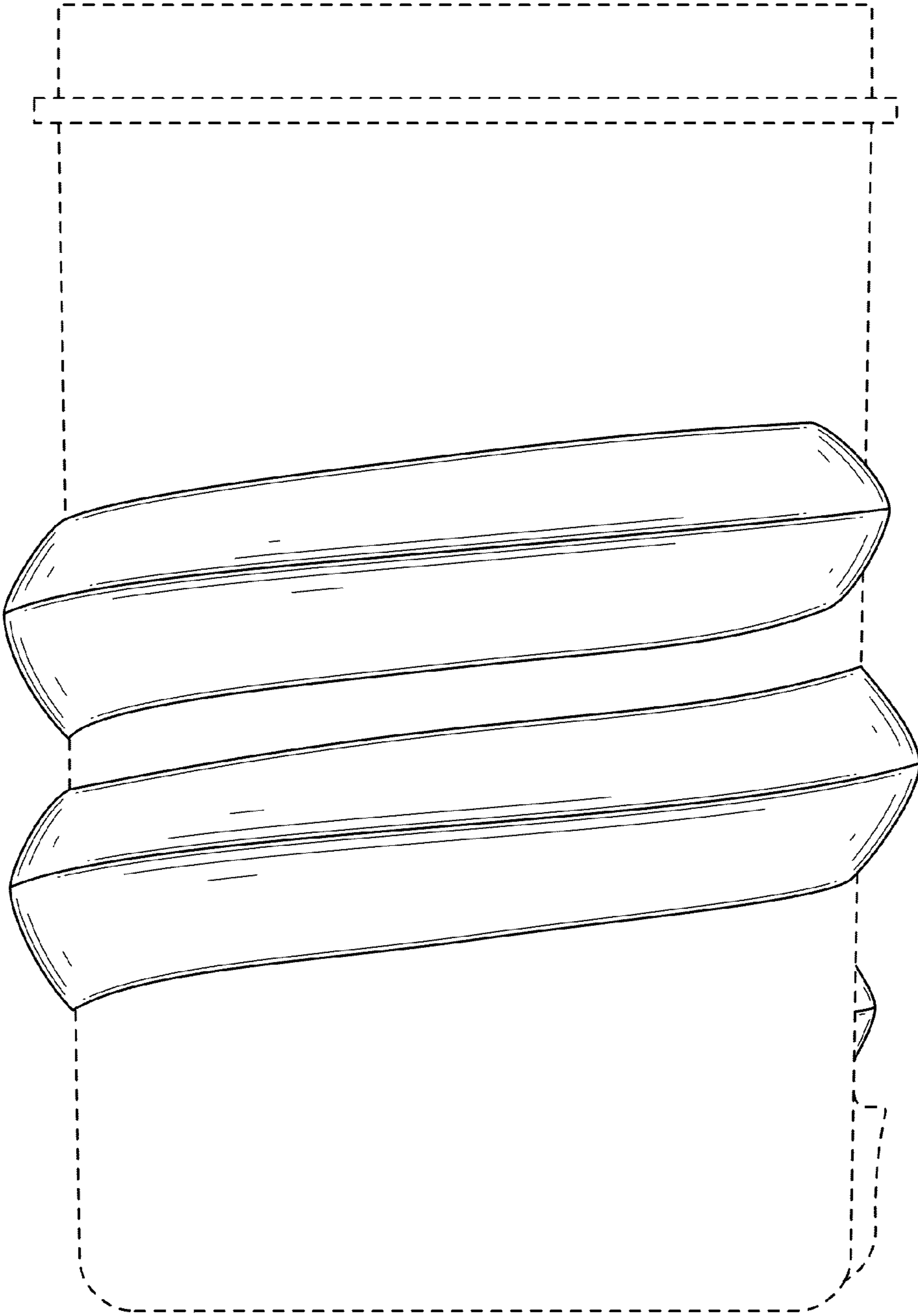

FIG. 12

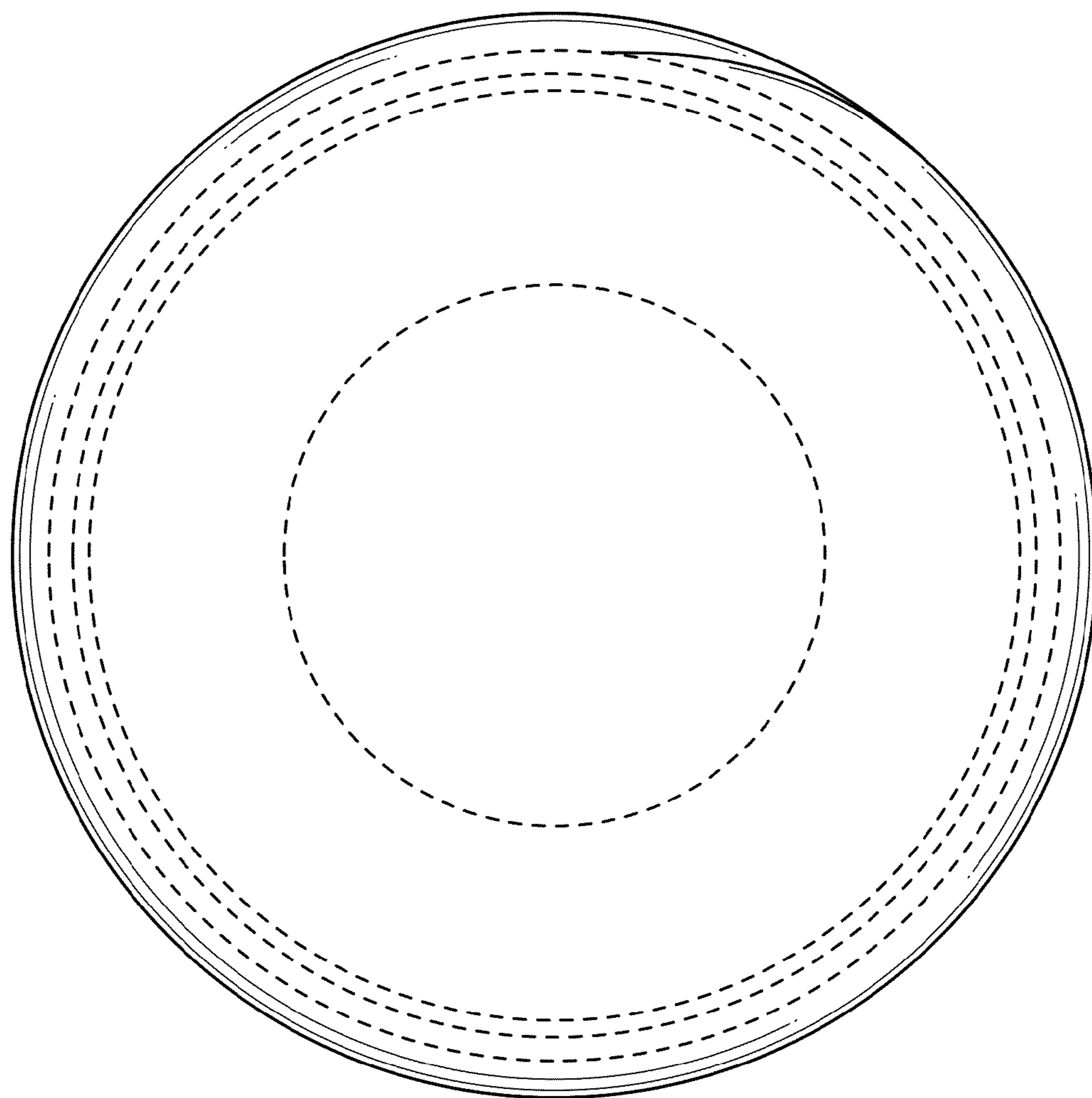

FIG. 13

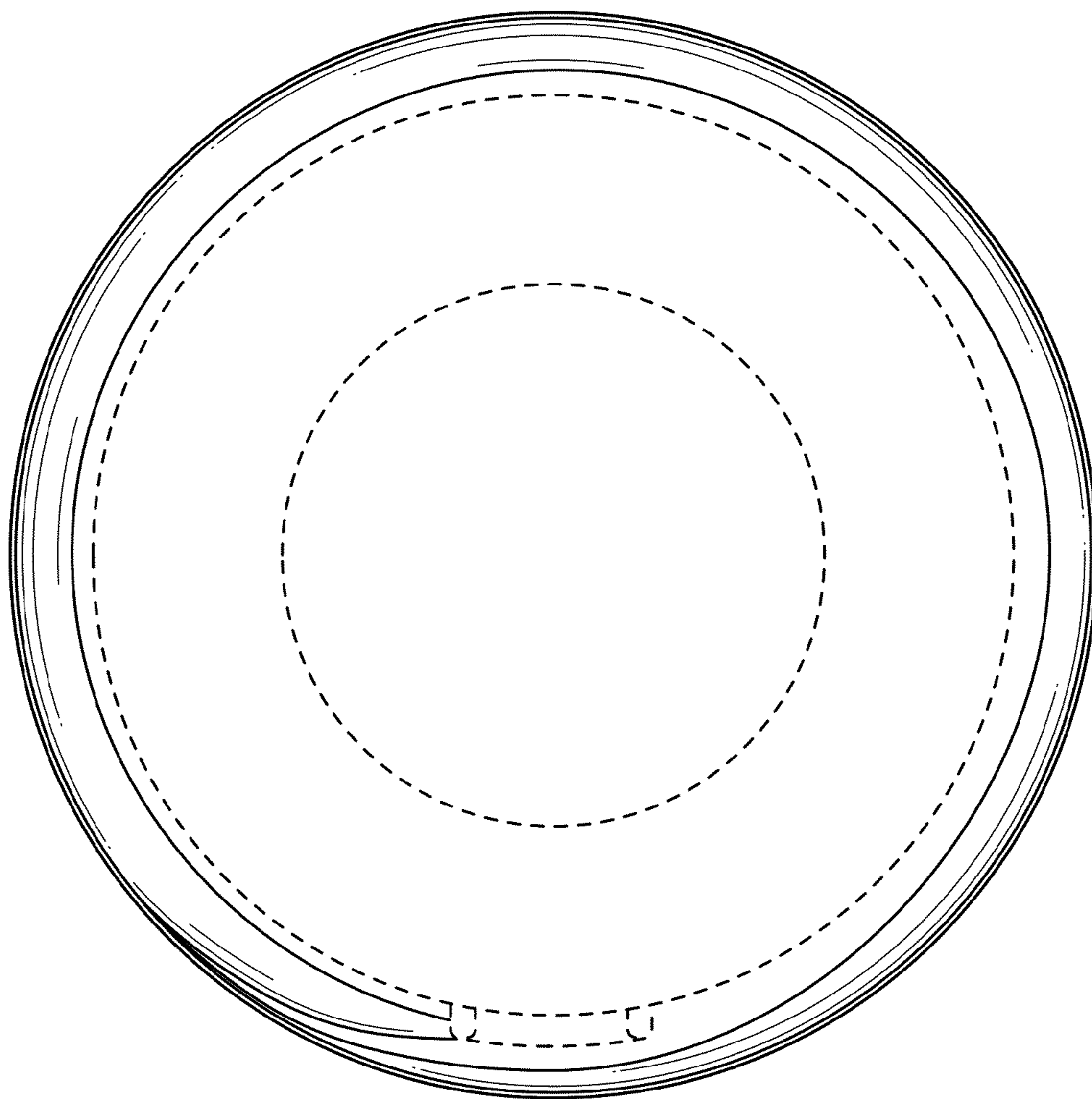

FIG. 14