



US00D701560S

(12) **United States Design Patent**
Huotari

(10) **Patent No.:** **US D701,560 S**
(45) **Date of Patent:** **** Mar. 25, 2014**

(54) **HARD COVER BOOK BINDING MACHINE**

(71) Applicant: **Maping Kommandiittiyhtio L.**
Huotari, Espoo (FI)

(72) Inventor: **Iisakki Huotari, Espoo (FI)**

(73) Assignee: **Maping Kommandiittiyhtio L. Huotari**
(FI)

(**) Term: **14 Years**

(21) Appl. No.: **29/446,894**

(22) Filed: **Feb. 28, 2013**

(30) **Foreign Application Priority Data**

Sep. 10, 2012 (DE) 402012100732

(51) **LOC (10) Cl.** **18-04**

(52) **U.S. Cl.**
USPC **D18/34.1**

(58) **Field of Classification Search**
USPC D18/34.1, 34.3, 34.9; D19/72;
83/613-614, 276, 933-934; 156/908;
241/36, 37.5, 100, 236; 270/52.18,
270/58.08, 45, 58.07; 412/4, 10, 14, 16, 19,
412/25, 33, 17-18, 22-23, 29, 32, 34
See application file for complete search history.

(56) **References Cited**

U.S. PATENT DOCUMENTS

- D276,528 S * 11/1984 Shaffer D18/34.8
- D322,974 S * 1/1992 Mori D18/34.8
- 5,318,398 A * 6/1994 Kojima 412/25
- 5,322,001 A * 6/1994 Boda 83/614
- D379,193 S * 5/1997 Cornell D18/34.8
- 5,819,618 A * 10/1998 Rodriguez 83/614
- D415,519 S * 10/1999 Mori D18/34.8
- D425,548 S * 5/2000 Rellinger D18/34.8

- 6,447,230 B1 * 9/2002 Takai et al. 412/14
- 6,460,443 B1 * 10/2002 Hsiao 83/614
- 6,672,815 B2 * 1/2004 Parker et al. 412/33
- D559,305 S * 1/2008 Lam et al. D18/34.8
- D593,598 S * 6/2009 Phillips et al. D18/34.8
- D636,432 S * 4/2011 Huotari et al. D18/34.1
- 8,052,135 B2 * 11/2011 Katayama et al. 270/58.08
- D667,870 S * 9/2012 Huotari D18/34.1
- 8,317,447 B2 * 11/2012 Jin 412/16
- D675,251 S * 1/2013 Roberts et al. D18/34.3
- 8,469,647 B2 * 6/2013 Garlichs et al. 412/10

OTHER PUBLICATIONS

- Fastbind H530, May 2001.
- Fastbind Casematic Lite, Jan. 2005.
- Fastbind Casematic H46 Pro, Jan. 2009.
- Fastbind Casematic H32, Jan. 2009.
- Fastbind Casematic H32L, Jan. 2009.
- Fastbind Casematic H32 Pro, Jan. 2009.

* cited by examiner

Primary Examiner — Cathy A MacCormac
(74) *Attorney, Agent, or Firm* — Bourque and Associates, PA

(57) **CLAIM**
The ornamental design for the hard cover book binding machine, as shown and described.

DESCRIPTION

FIG. 1 is a rear view of the hard cover book binding machine according to the invention;
FIG. 2 is a front view thereof;
FIG. 3 is a top view thereof;
FIG. 4 is a bottom view thereof;
FIG. 5 is a right side view thereof;
FIG. 6 is a left side view thereof; and,
FIG. 7 is a perspective view taken from the front, right side thereof.

1 Claim, 7 Drawing Sheets

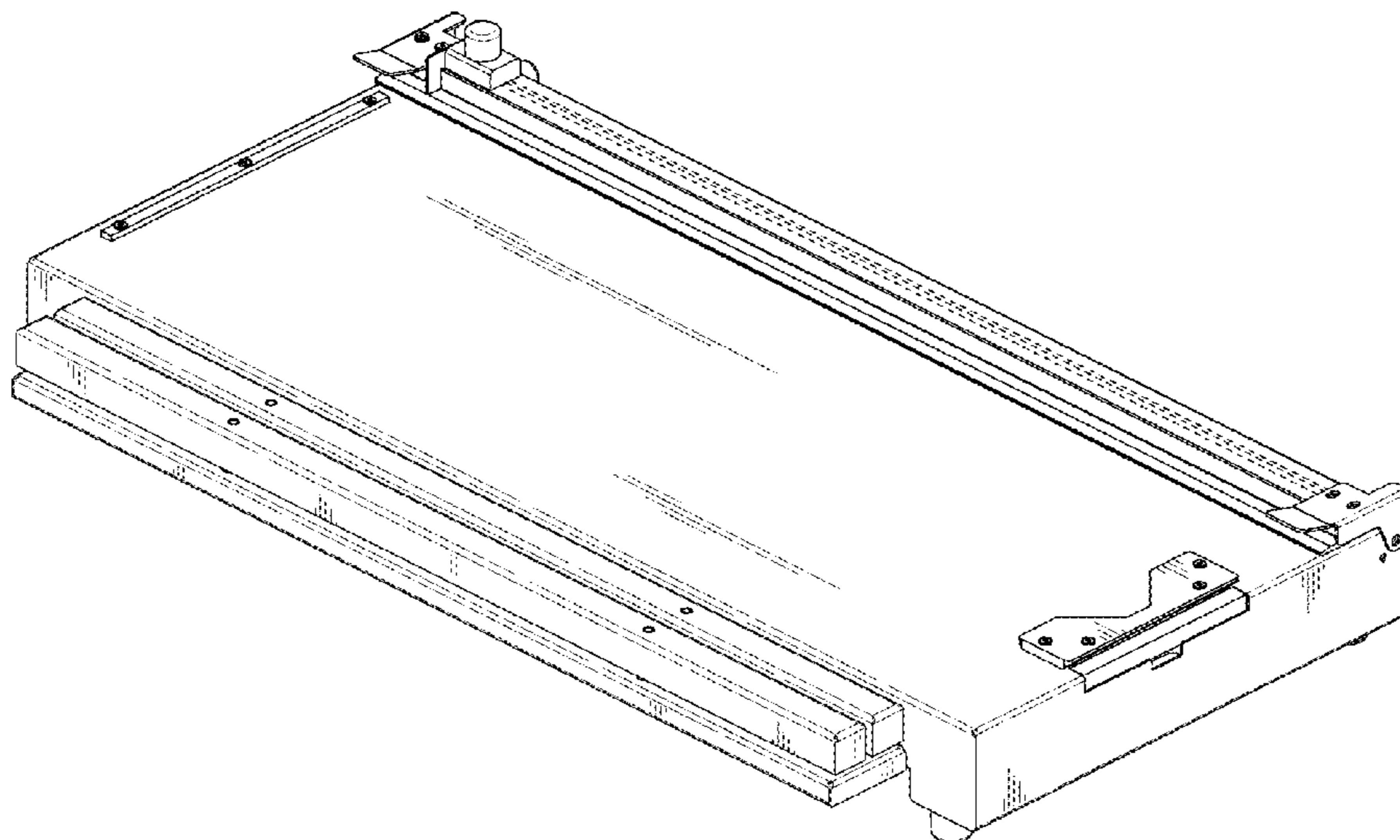

FIG 1

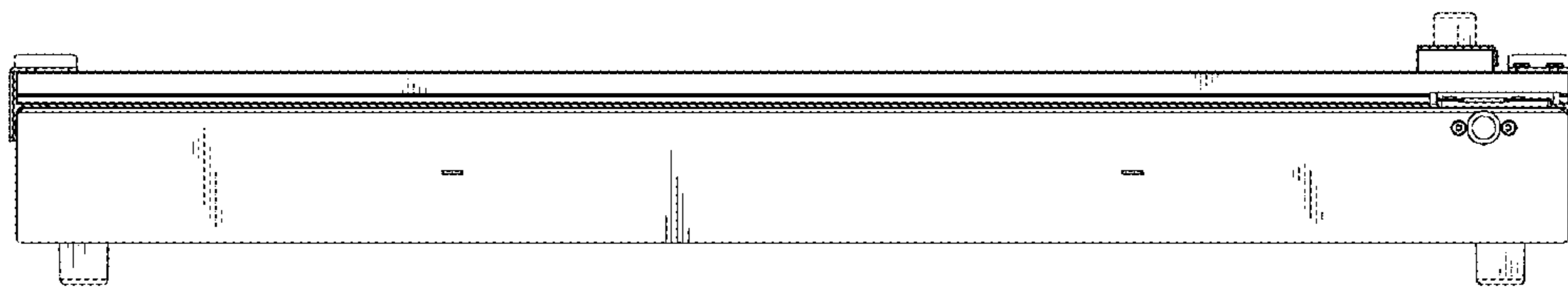

FIG 2

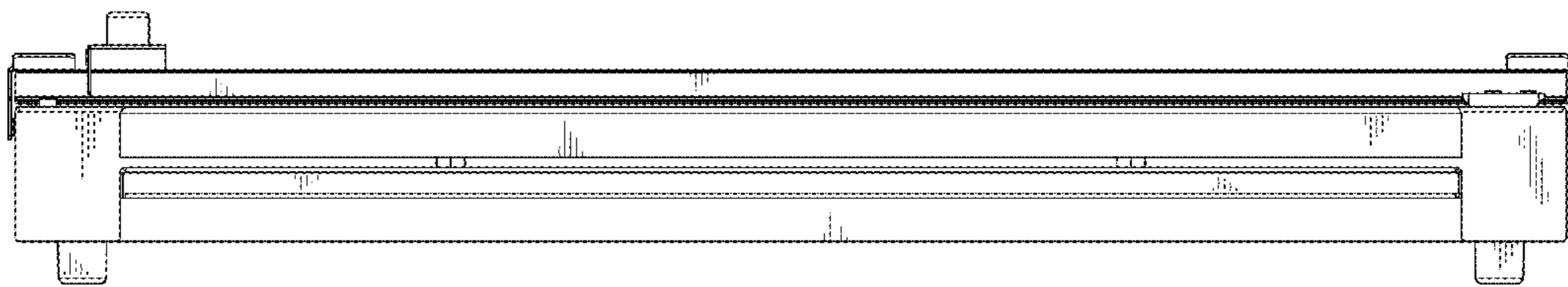

FIG 3

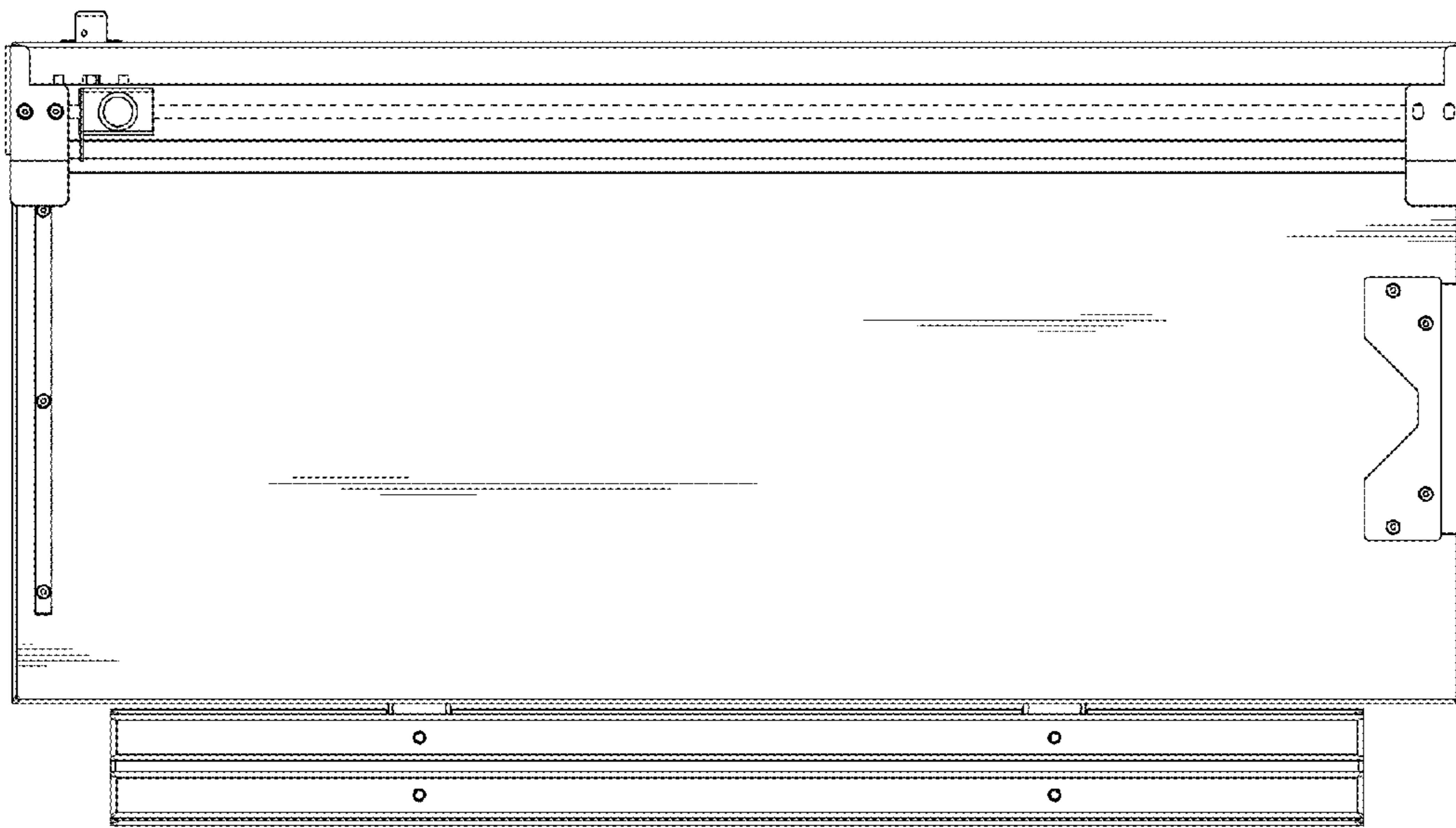

FIG 4

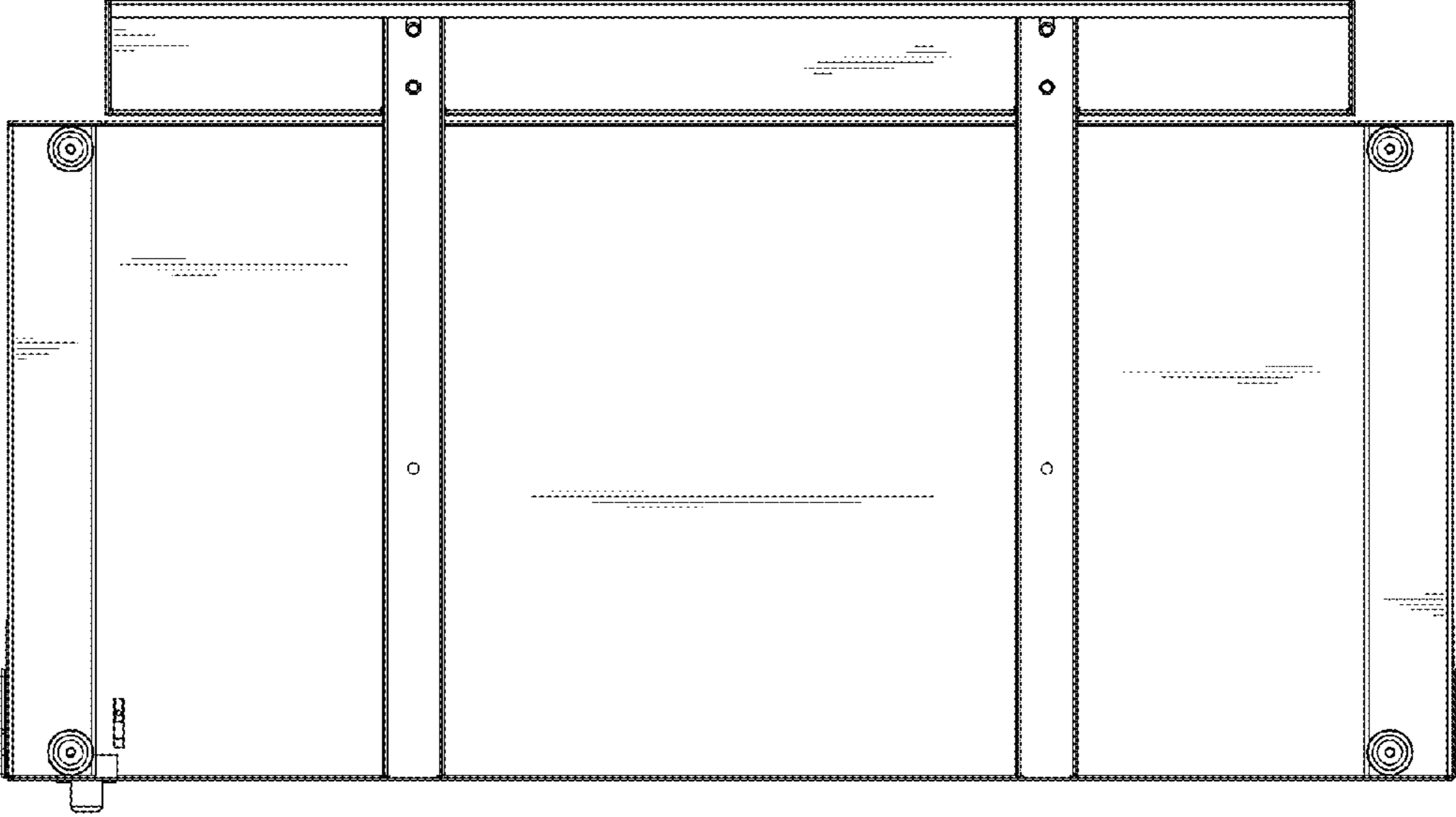

FIG 5

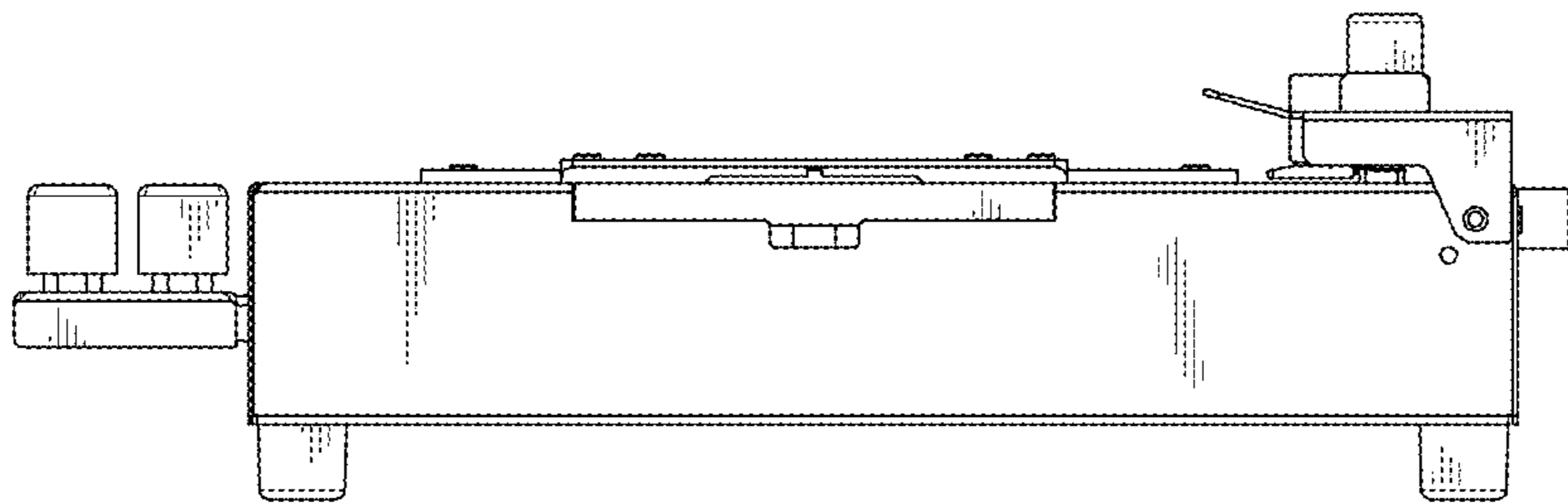

FIG 6

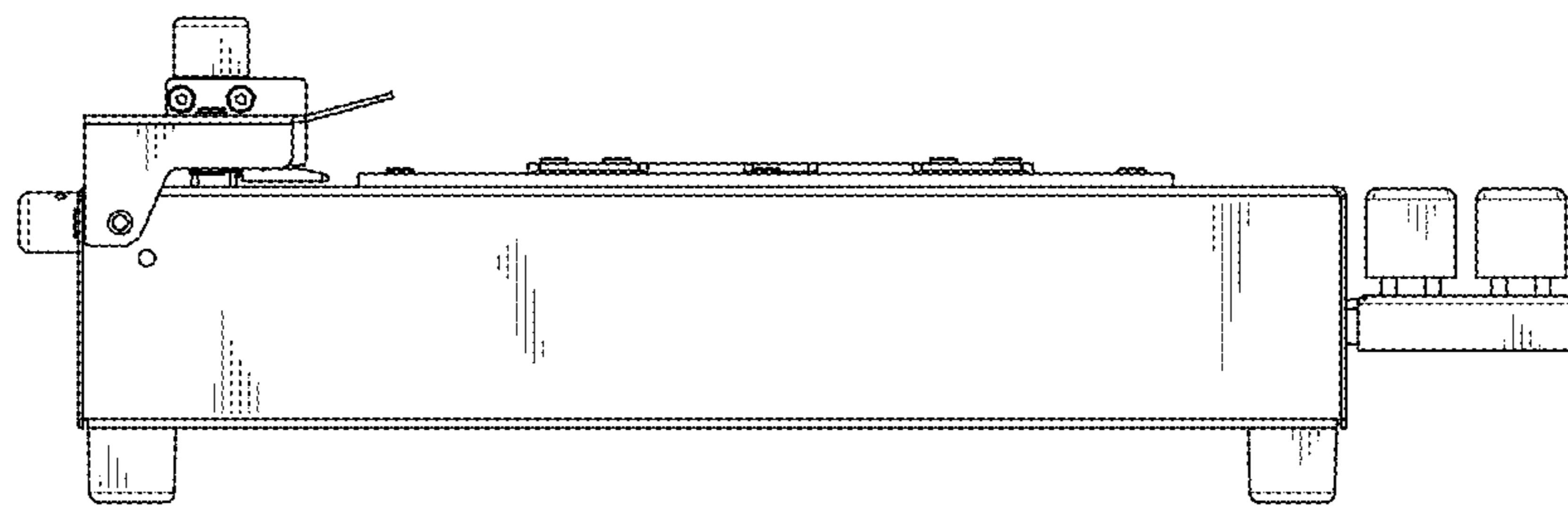

FIG 7

