



US00D701477S

(12) **United States Design Patent**
Yeung

(10) **Patent No.:** **US D701,477 S**
(45) **Date of Patent:** **** Mar. 25, 2014**

(54) **AUTOMOTIVE STEERING COLUMN COVER**

(76) Inventor: **Winston Yeung**, North Vancouver (CA)

(**) Term: **14 Years**

(21) Appl. No.: **29/406,841**

(22) Filed: **Nov. 18, 2011**

(51) **LOC (10) Cl.** **12-16**

(52) **U.S. Cl.**
USPC **D12/177**

(58) **Field of Classification Search**
USPC D10/46, 98, 102, 103, 106; D12/175,
D12/176, 177, 192; D15/17; 180/90;
200/61.54; 280/750; 296/70
See application file for complete search history.

(56) **References Cited**

U.S. PATENT DOCUMENTS

D288,430	S	2/1987	Cornwell	
D301,541	S *	6/1989	Gifford	D8/331
D311,857	S *	11/1990	Webster	D8/333
D349,034	S *	7/1994	Webster	D8/333
D379,610	S *	6/1997	Hellhake et al.	D12/174
D389,724	S *	1/1998	Webster	D8/333
D439,554	S *	3/2001	Jolley	D12/174
D478,297	S	8/2003	Cadotte et al.	
D478,832	S	8/2003	Dipple	
D480,341	S	10/2003	Day	
D489,661	S	5/2004	McPeck et al.	
D491,825	S *	6/2004	Day et al.	D10/103
D492,213	S *	6/2004	Day et al.	D10/103
D512,357	S	12/2005	Schuttera	
D514,994	S	2/2006	Day	
7,180,020	B2 *	2/2007	Onoda et al.	200/61.54
D538,720	S *	3/2007	Yeung	D12/192

D579,402	S *	10/2008	Ball et al.	D12/223
D592,115	S *	5/2009	Domin	D12/177
D593,913	S *	6/2009	Yeung	D12/177
D593,914	S *	6/2009	Yeung	D12/177
7,595,457	B2	9/2009	Heite et al.	
D611,884	S *	3/2010	Yeung	D12/177
D620,405	S *	7/2010	Yeung	D12/177
D643,791	S *	8/2011	Yeung	D12/177
D649,606	S *	11/2011	Markowitz et al.	D21/561
2009/0194349	A1 *	8/2009	Myers	180/90

* cited by examiner

Primary Examiner — Phillip S Hyder

(74) *Attorney, Agent, or Firm* — C. Larry Kyle; Nexus Law Group LLP

(57) **CLAIM**

The ornamental design for an automotive steering column cover, as shown and described.

DESCRIPTION

FIG. 1 is a front, top right perspective view of an automotive steering column cover, showing my new design; FIG. 2 is a front elevation view thereof; FIG. 3 is a rear elevation view thereof; FIG. 4 is a top plan view thereof; FIG. 5 is a bottom plan view thereof; FIG. 6 is a left side elevation view thereof; FIG. 7 is a right side elevation view thereof; FIG. 8 is a top perspective view thereof from the rear; and, FIG. 9 is a bottom perspective view thereof from the rear. The broken lines illustrate portions of an automotive steering column cover that form no part of the claimed design.

1 Claim, 3 Drawing Sheets

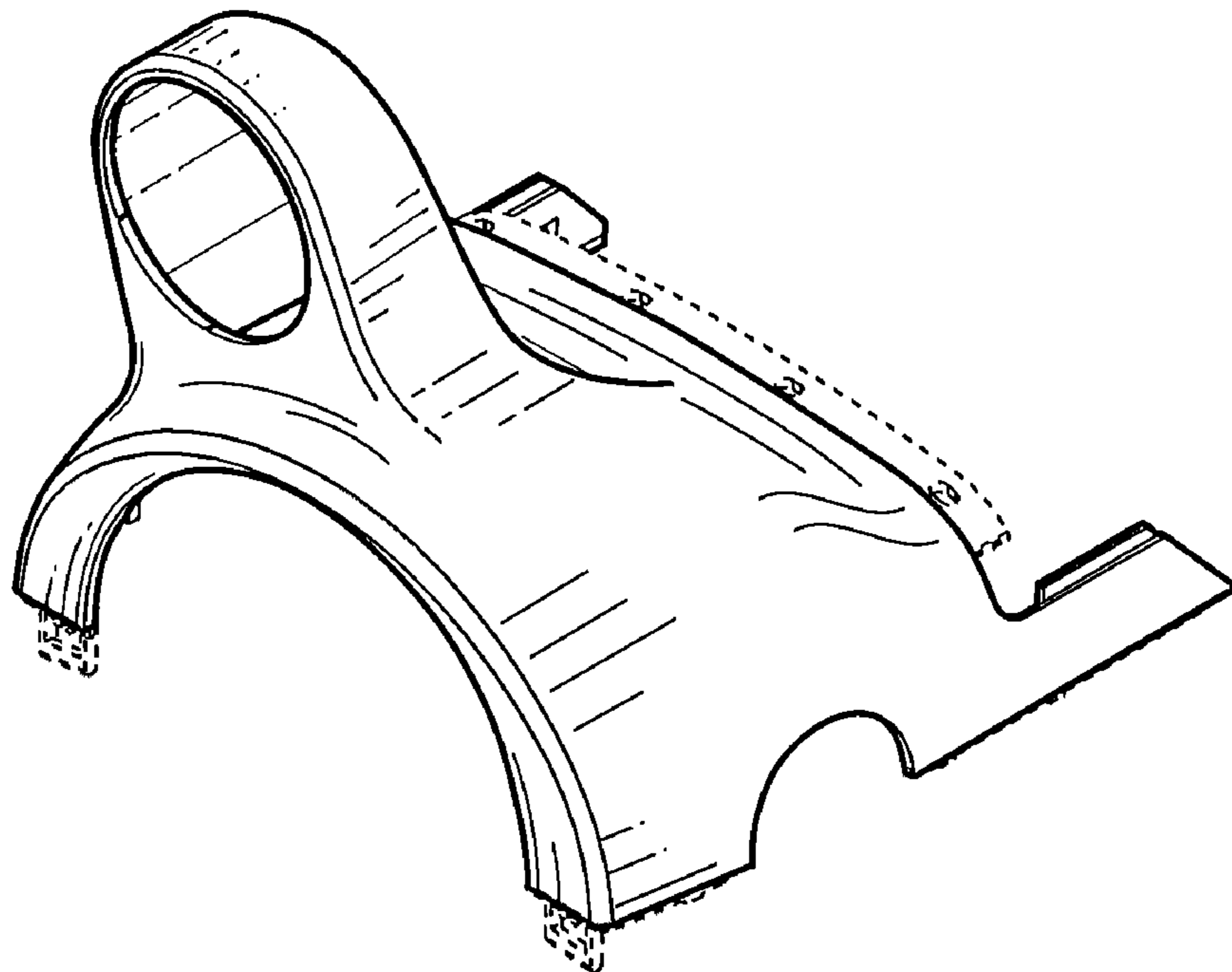

FIGURE-1

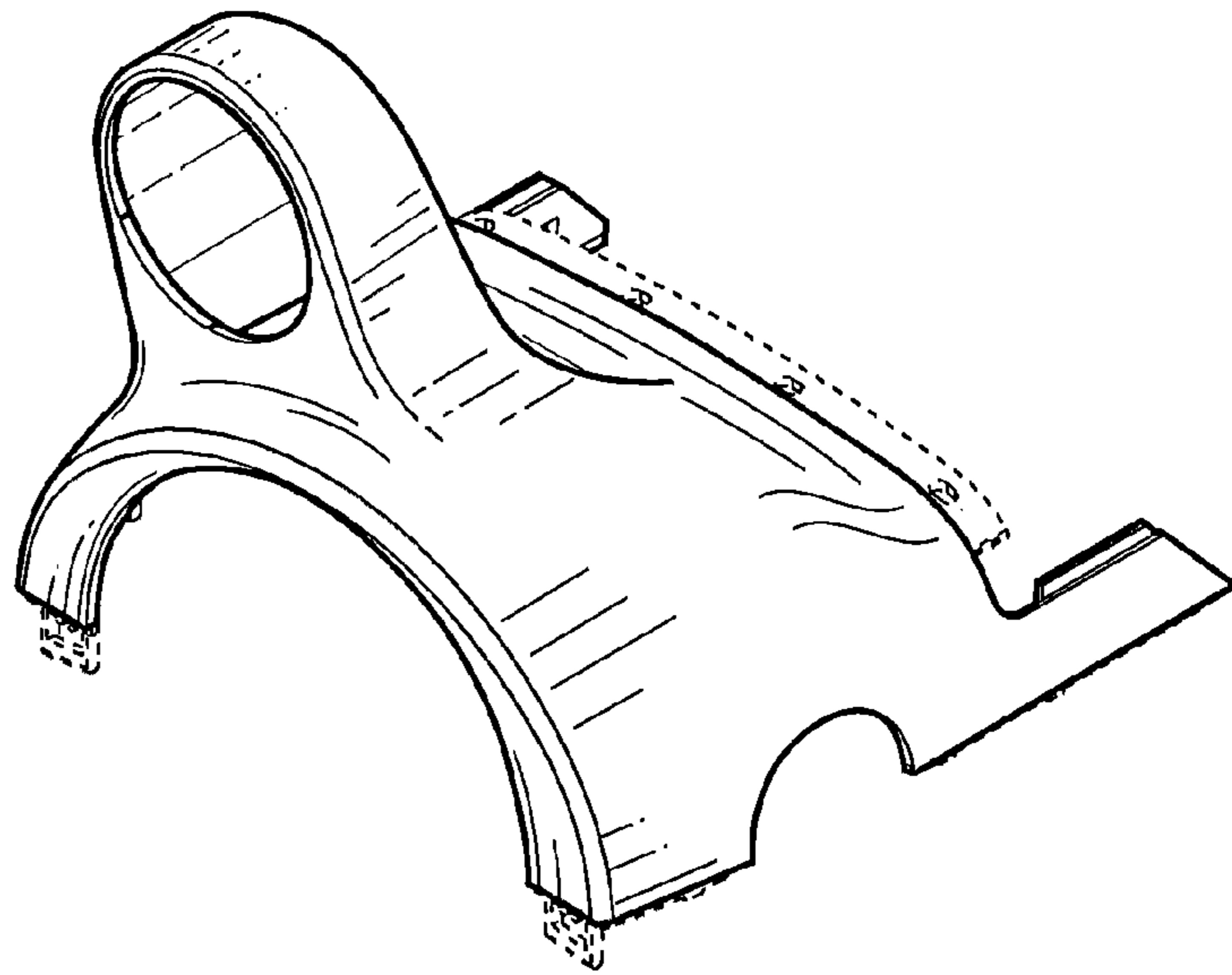

FIGURE-2

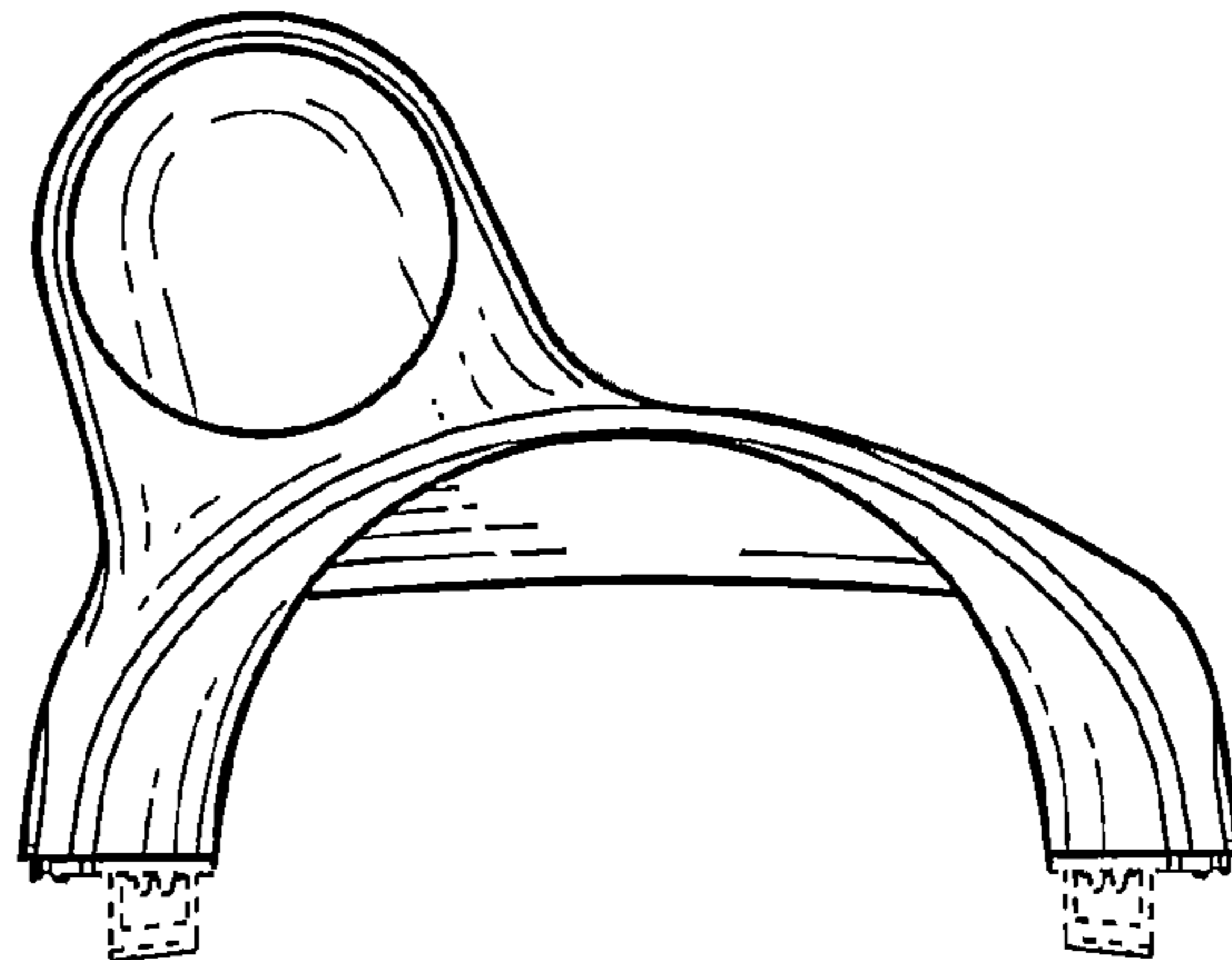

FIGURE-3

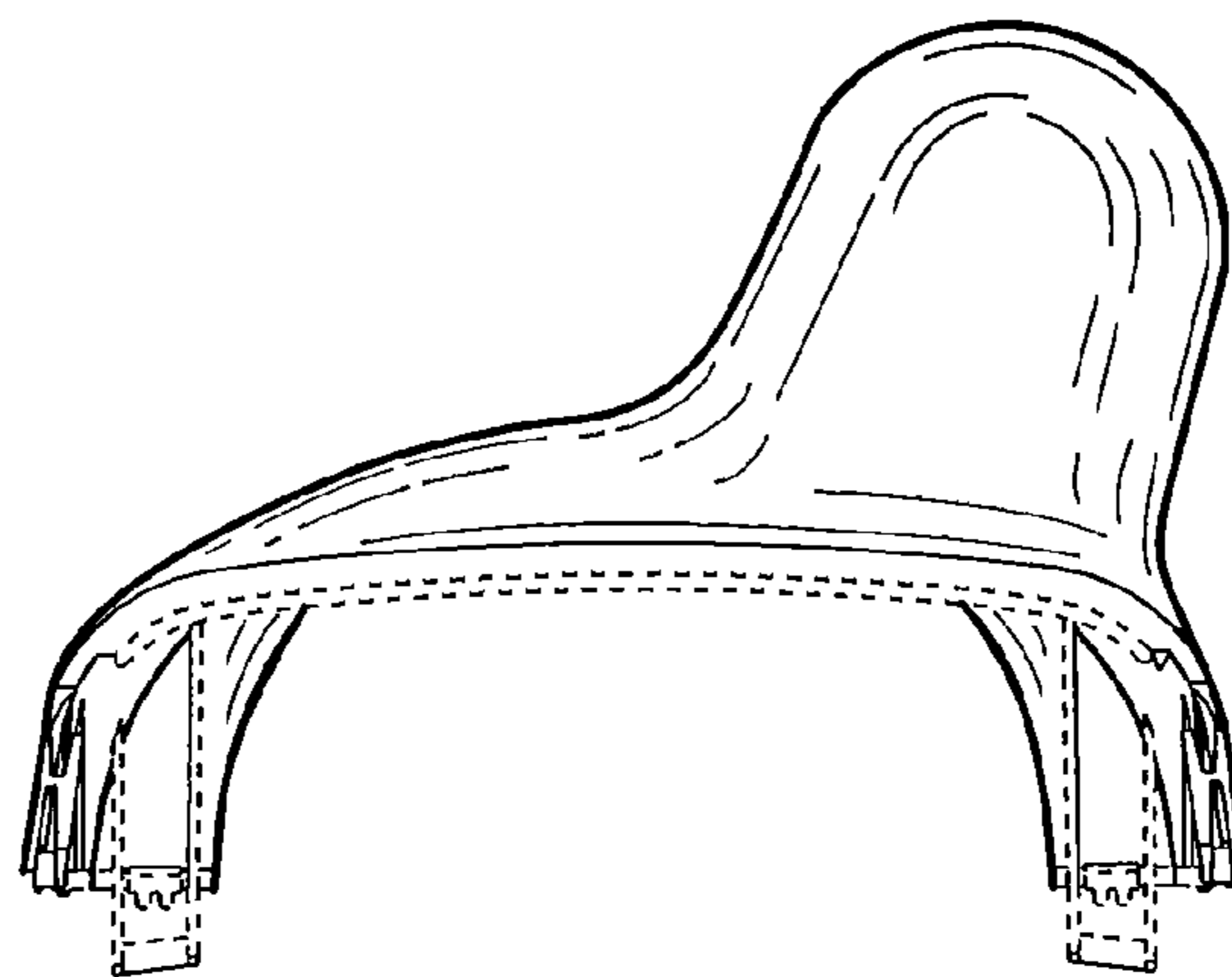

FIGURE-4

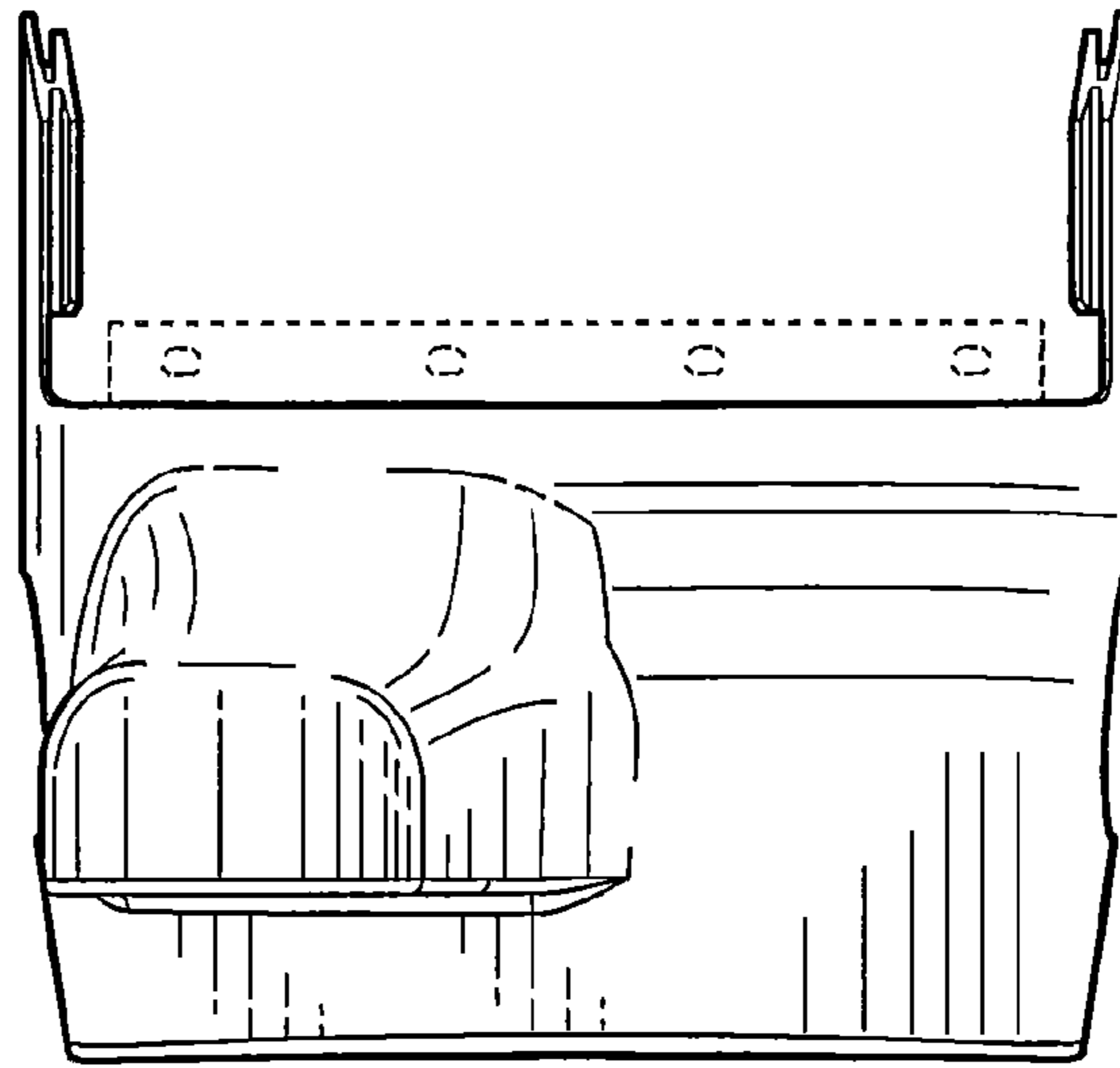

FIGURE-5

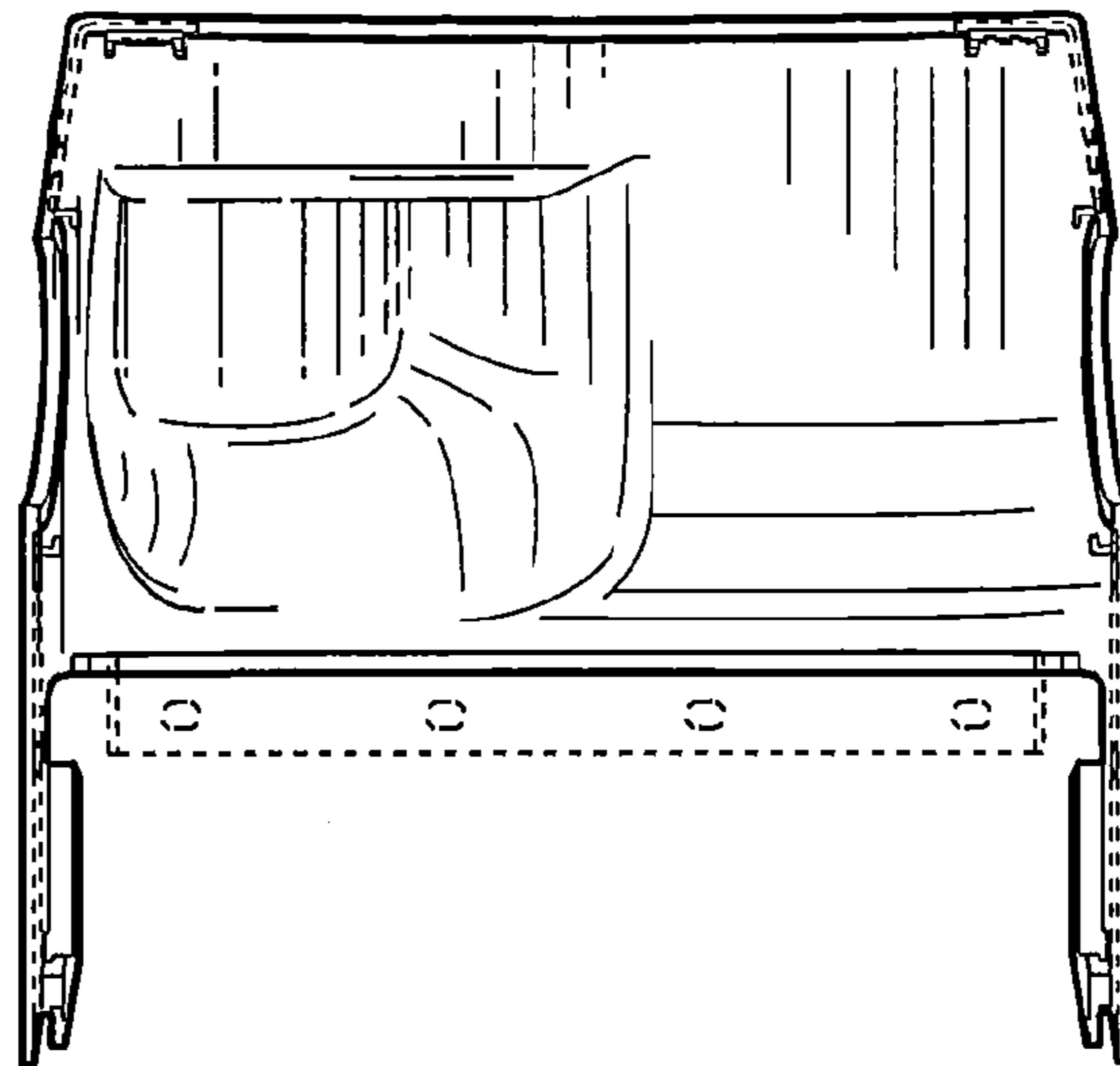

FIGURE-6

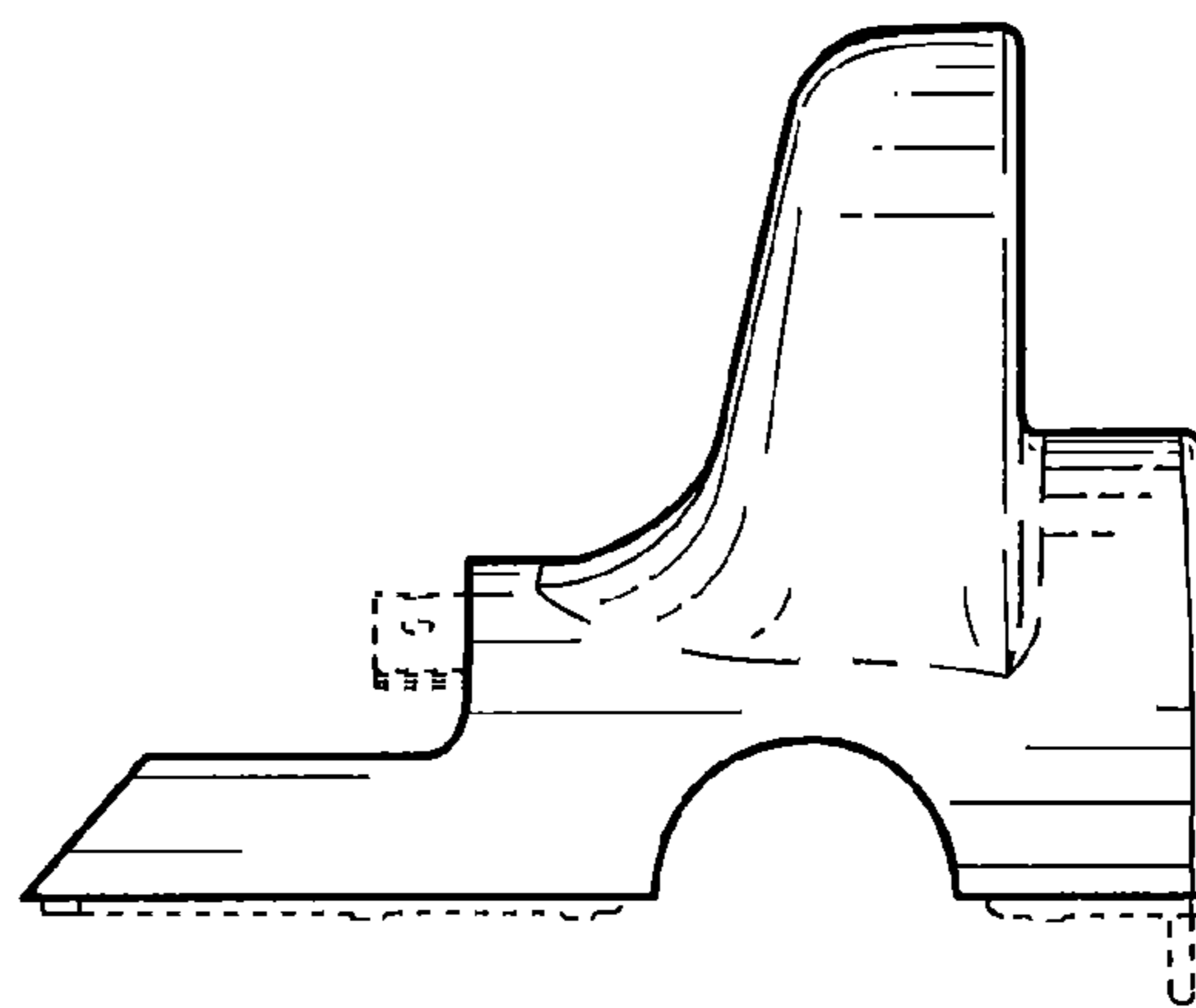

FIGURE-7

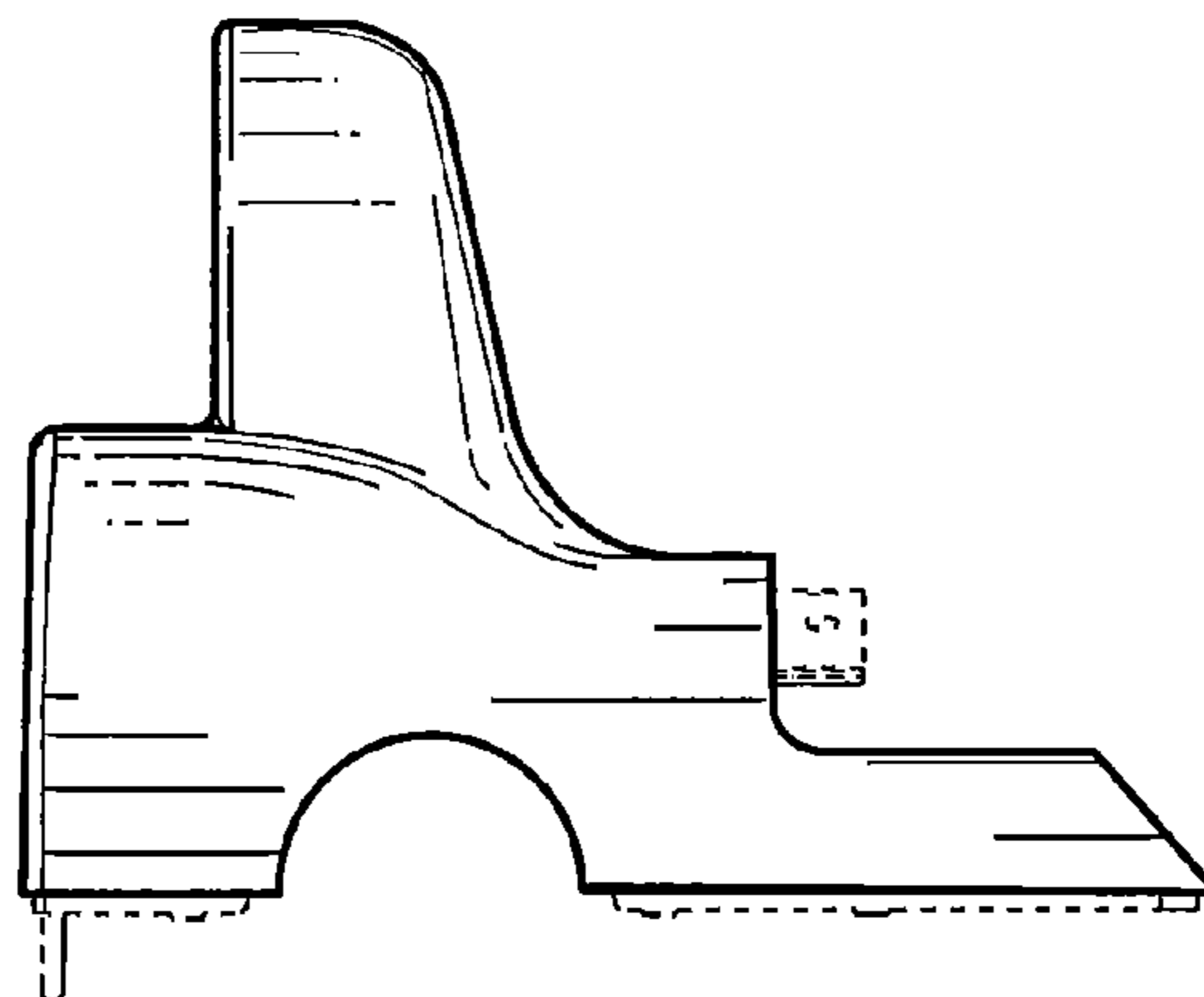

FIGURE-8

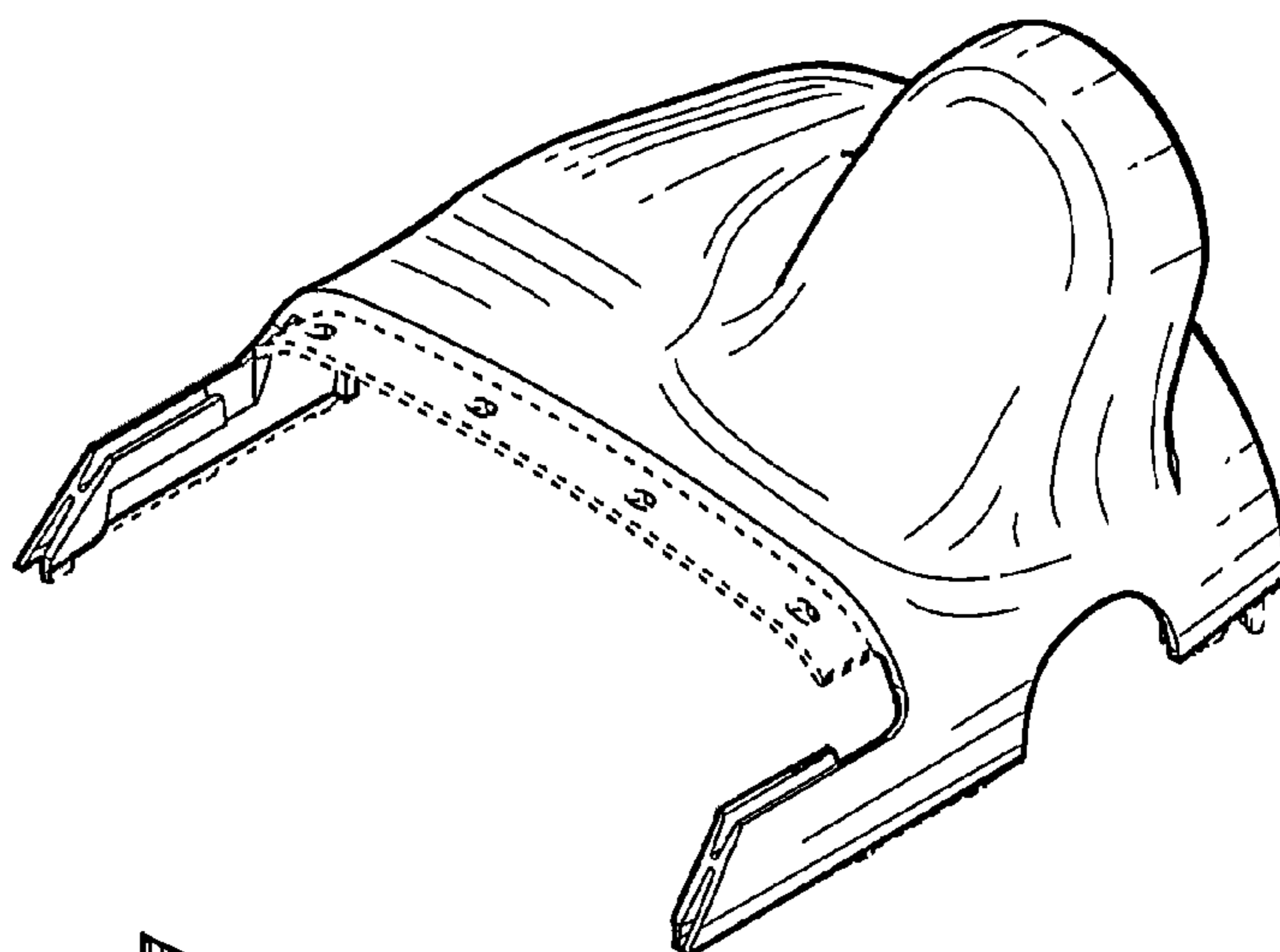

FIGURE-9

