



US00D701475S

(12) **United States Design Patent**  
**Matsumoto et al.**

(10) **Patent No.:** **US D701,475 S**  
(45) **Date of Patent:** **\*\* \*Mar. 25, 2014**

(54) **AUTOMOBILE AND/OR TOY REPLICA THEREOF**

(75) Inventors: **Kengo Matsumoto**, Nagoya (JP);  
**Shinichi Hiranaka**, Miyoshi (JP); **Shin Miyata**, Nissin (JP); **Satoru Sugimoto**, Toyota (JP)

(73) Assignee: **Toyota Jidosha Kabushiki Kaisha** (JP)

(\*) Notice: This patent is subject to a terminal disclaimer.

(\*\*) Term: **14 Years**

(21) Appl. No.: **29/431,238**

(22) Filed: **Sep. 5, 2012**

**Related U.S. Application Data**

(62) Division of application No. 29/388,890, filed on Apr. 4, 2011, now Pat. No. Des. 669,406.

(30) **Foreign Application Priority Data**

Jan. 7, 2011 (JP) ..... 2011-000242  
Jan. 7, 2011 (JP) ..... 2011-000243  
Jan. 7, 2011 (JP) ..... 2011-000244  
Jan. 7, 2011 (JP) ..... 2011-000245  
Jan. 7, 2011 (JP) ..... 2011-000246

(51) **LOC (10) Cl.** ..... **12-16**

(52) **U.S. Cl.**  
USPC ..... **D12/169**

(58) **Field of Classification Search**  
USPC ..... D12/163, 196, 171, 169, 216, 90-92,  
D12/86; 180/68.1, 68.6; 296/193.11  
See application file for complete search history.

(56) **References Cited**

**U.S. PATENT DOCUMENTS**

D501,435 S 2/2005 Hosoda et al.  
D536,284 S 2/2007 Nakamura et al.

D538,716 S 3/2007 Hogios  
D539,196 S 3/2007 Pfeiffer  
D539,707 S 4/2007 Golden et al.  
D578,444 S 10/2008 Kuo  
D587,636 S 3/2009 Kanno et al.  
D592,560 S 5/2009 Bauer et al.  
D596,088 S 7/2009 Camacho et al.  
D605,989 S 12/2009 Leng et al.  
D619,514 S \* 7/2010 Syouji et al. .... D12/169  
D620,850 S \* 8/2010 Sakae et al. .... D12/169  
D637,533 S \* 5/2011 Miyazawa et al. .... D12/169  
D640,614 S \* 6/2011 Kumai et al. .... D12/169  
D640,958 S \* 7/2011 Yokoi et al. .... D12/169  
2006/0119115 A1 6/2006 Filip et al.

**OTHER PUBLICATIONS**

2009 Audi A6, www.netcarshow.com, posted by NetCarShow at least as early as 2009.

2011 Lexus CT200h, www.netcarshow.com, publicly known at least as early as Mar. 2010.

\* cited by examiner

*Primary Examiner* — Melody Brown

(74) *Attorney, Agent, or Firm* — SAIDMAN DesignLaw Group

(57) **CLAIM**

The ornamental design for an automobile and/or toy replica thereof, as shown and described.

**DESCRIPTION**

FIG. 1 is a perspective view of an automobile and/or toy replica thereof showing our new design;

FIG. 2 is a left side view thereof, the right side view being a mirror image;

FIG. 3 is a top view thereof;

FIG. 4 is a front view thereof;

FIG. 5 is an enlarged view showing a portion of FIG. 1 defined by line 5-5; and,

FIG. 6 is an enlarged view showing a portion of FIG. 4 defined by lines 6-6.

The broken lines illustrate environmental structure and form no part of the claimed design.

**1 Claim, 4 Drawing Sheets**

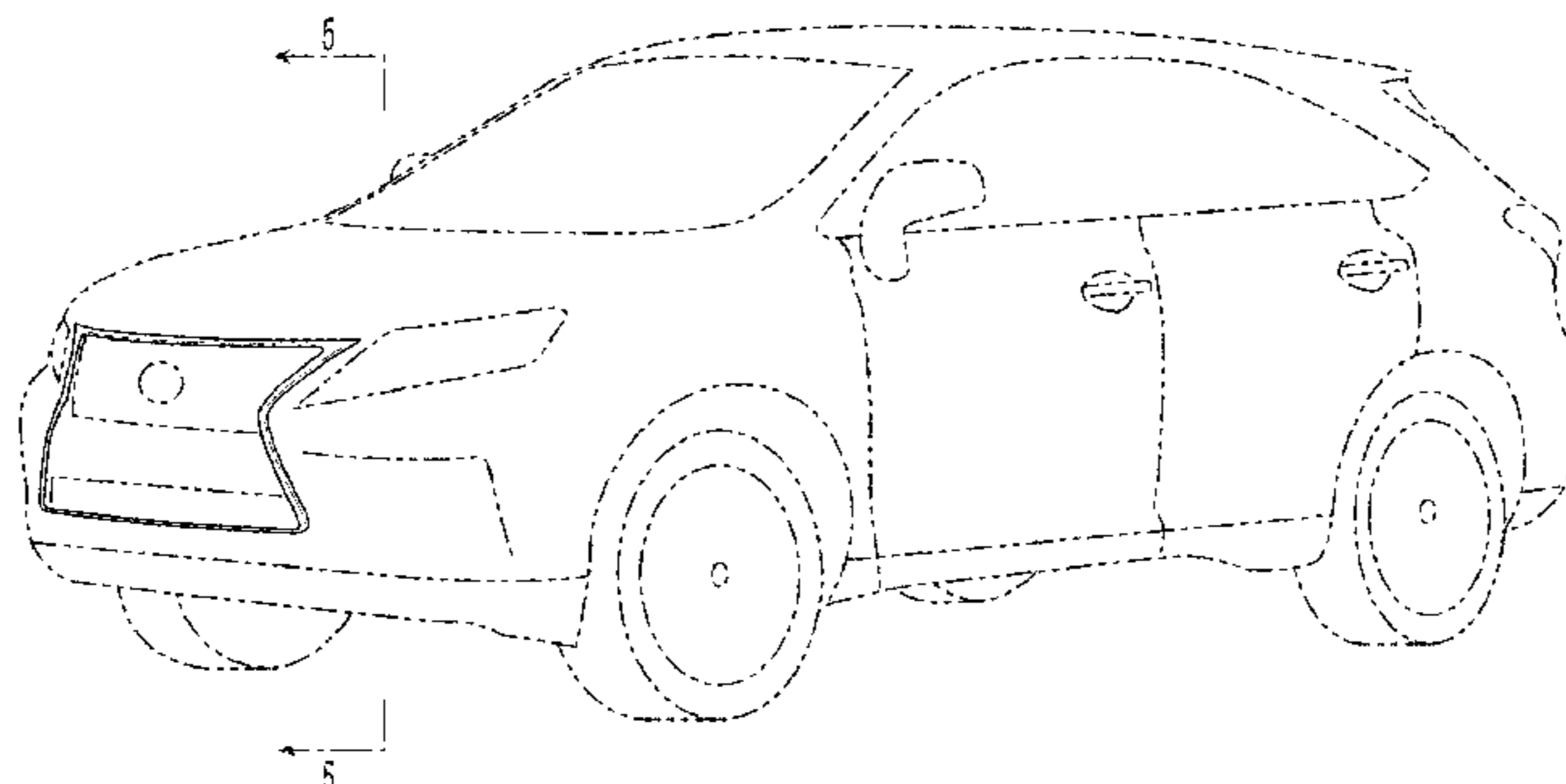

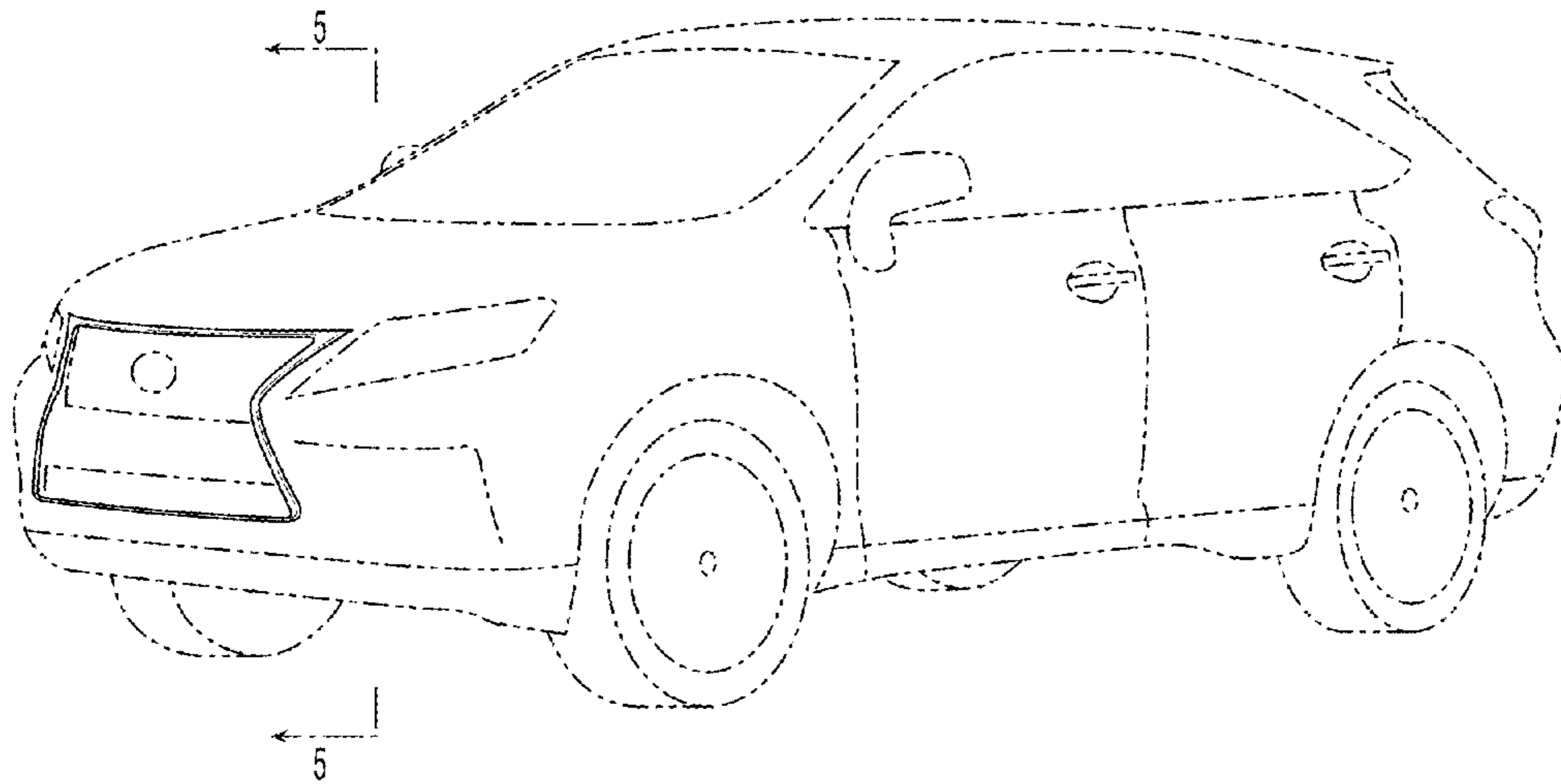

**Fig. 1**

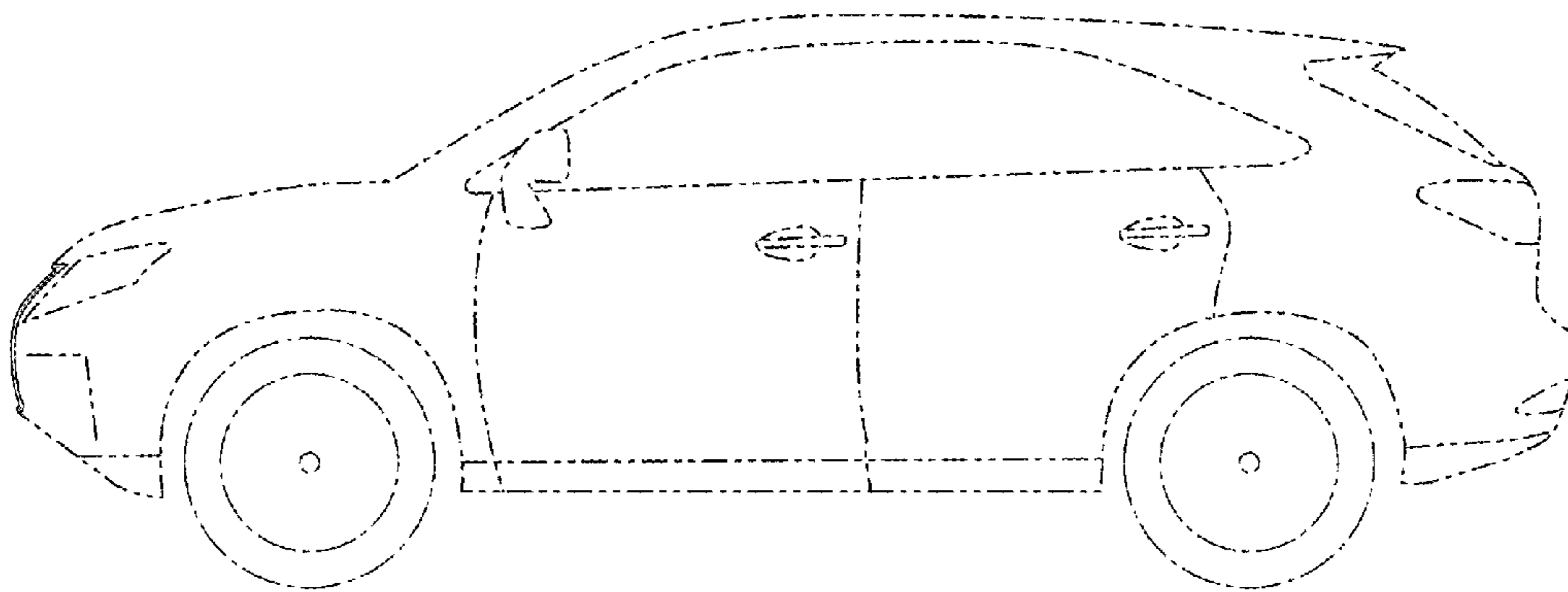

**Fig. 2**

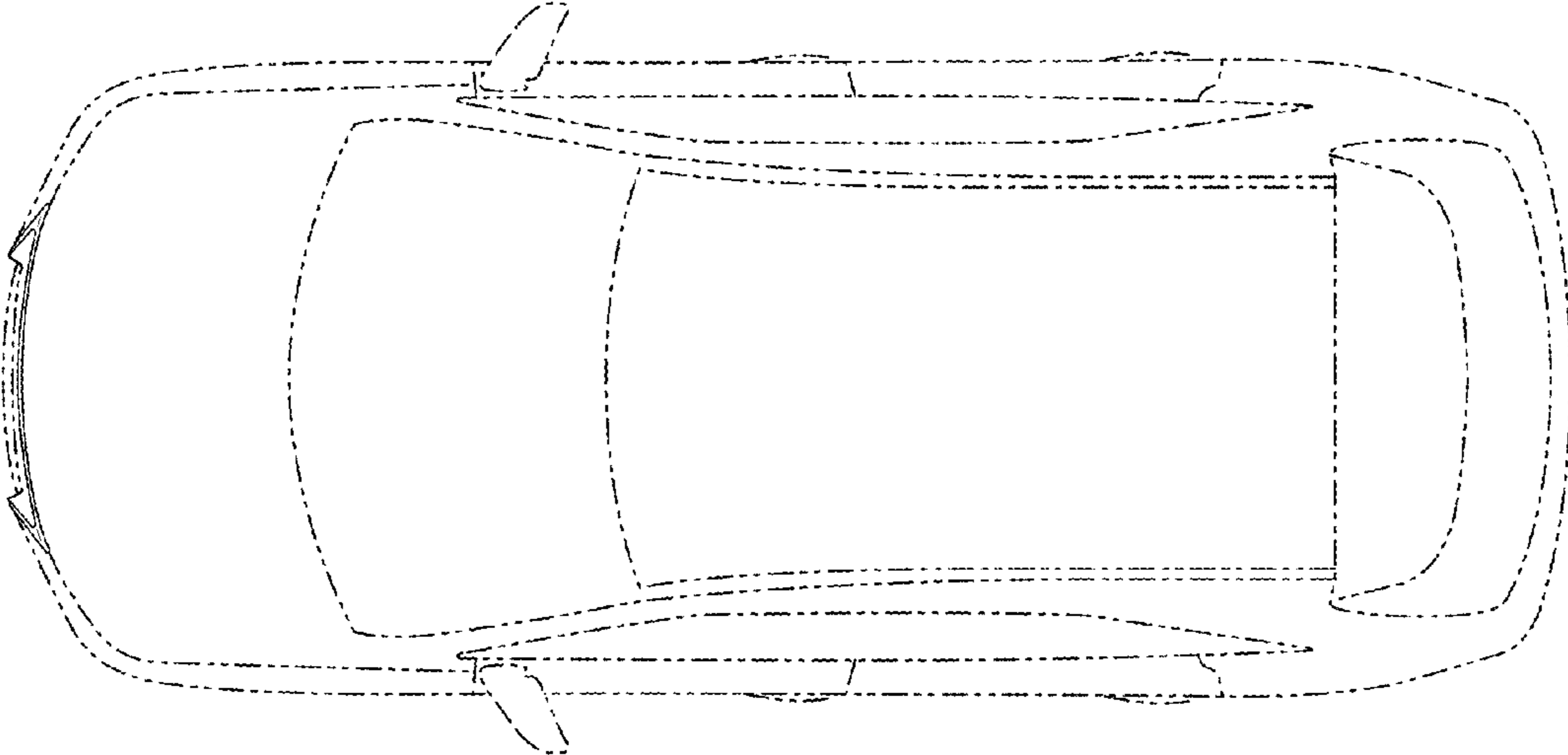

Fig. 3

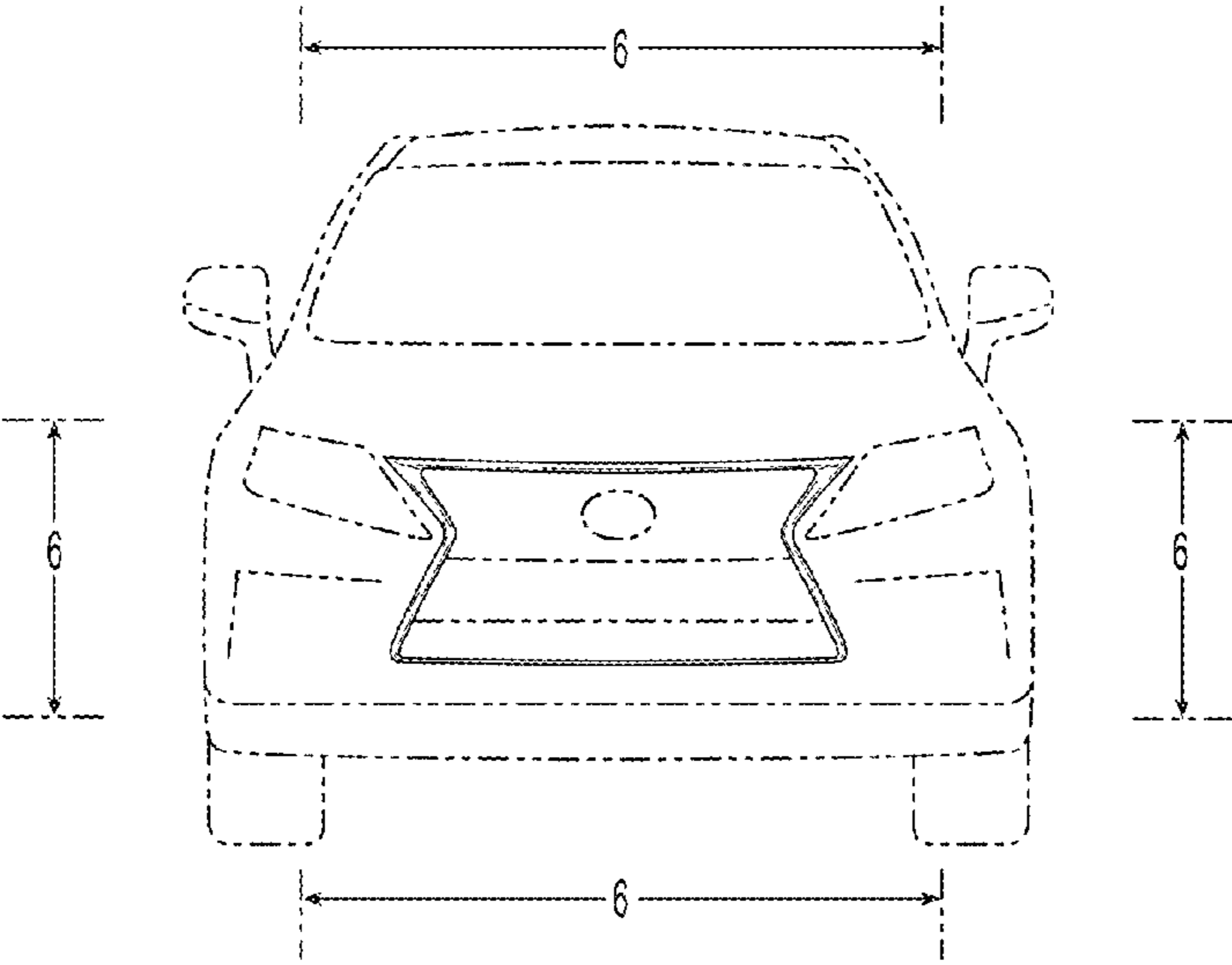
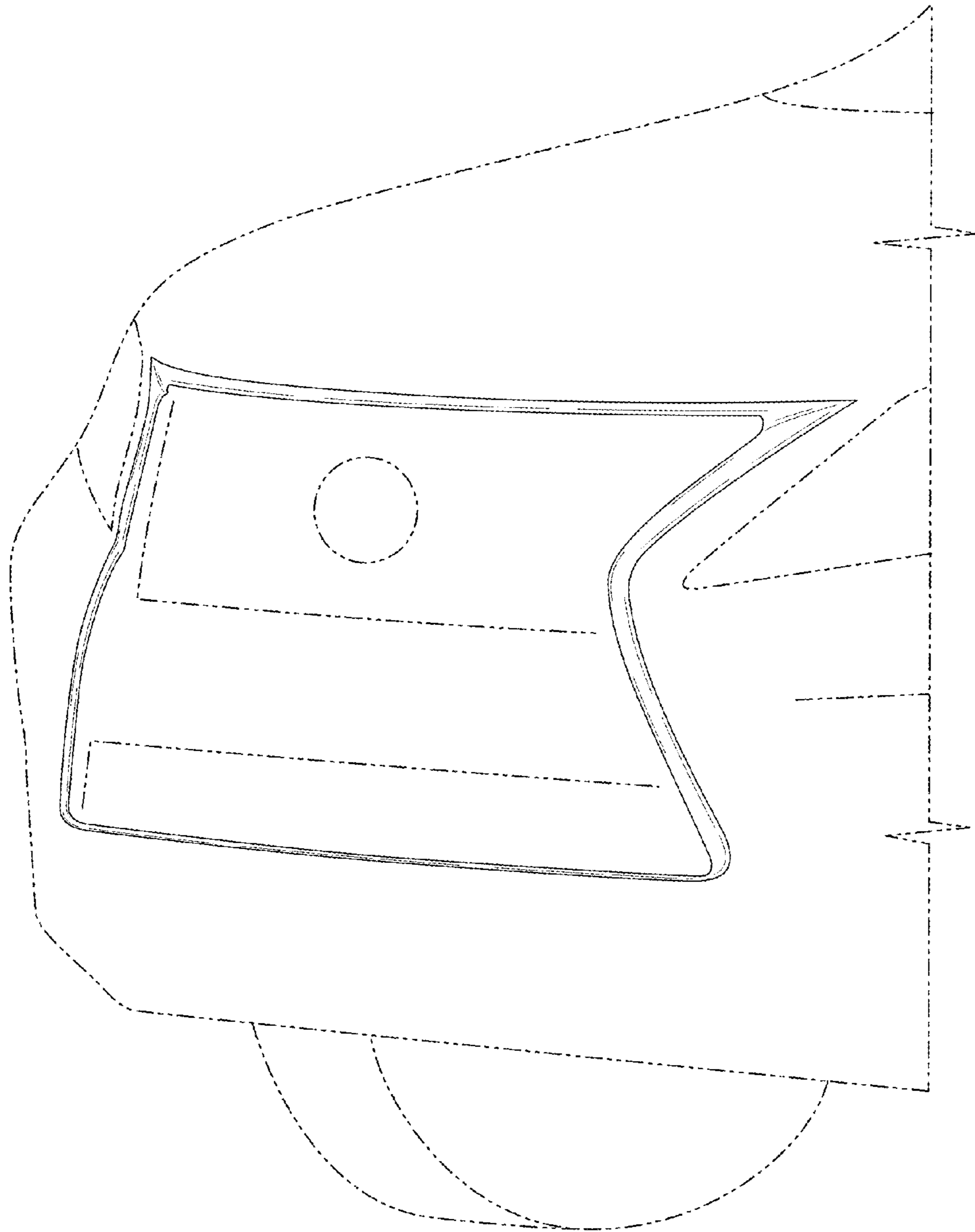
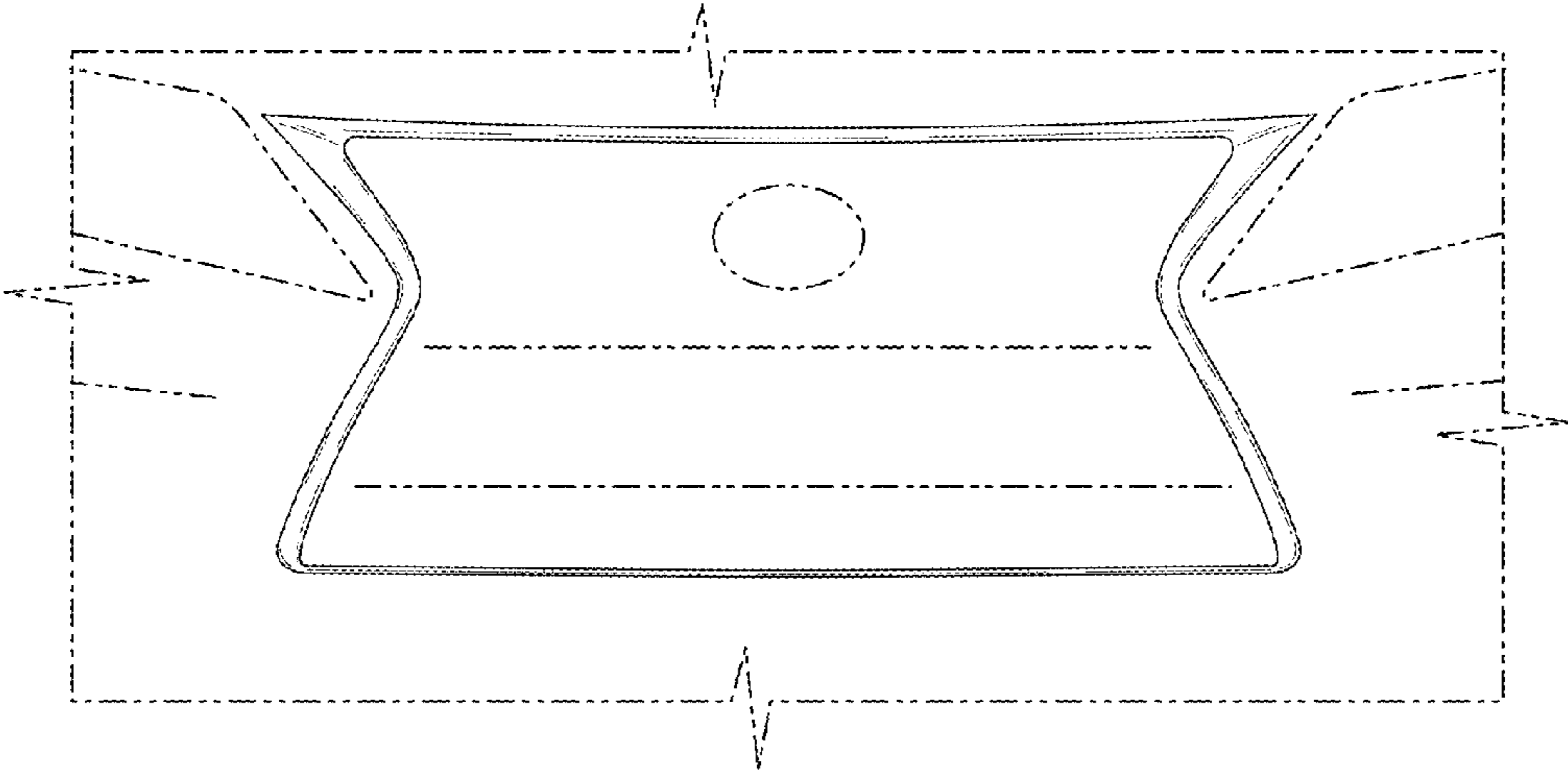

Fig. 4



**Fig. 5**



**Fig. 6**