



US00D701469S

(12) **United States Design Patent**  
**Lai et al.**

(10) **Patent No.:** **US D701,469 S**  
(45) **Date of Patent:** **\*\* Mar. 25, 2014**

(54) **ALL-TERRAIN VEHICLE**

(71) Applicant: **Zhejiang CFMOTO Power Co., Ltd,**  
Hangzhou (CN)

(72) Inventors: **Guogui Lai**, Hangzhou (CN);  
**Zhangping Yuan**, Hangzhou (CN);  
**Jinpin Zheng**, Hangzhou (CN);  
**Mingtang Chen**, Hangzhou (CN);  
**Yongbo Long**, Hangzhou (CN)

(73) Assignee: **Zhejiang CFMOTO Power Co., Ltd,**  
Hangzhou, Zhejiang Province (CN)

(\*\*) Term: **14 Years**

(21) Appl. No.: **29/448,956**

(22) Filed: **Mar. 14, 2013**

(30) **Foreign Application Priority Data**

Dec. 26, 2012 (CN) ..... 2012 3 0654301

(51) **LOC (10) Cl.** ..... **12-08**

(52) **U.S. Cl.**  
USPC ..... **D12/87**

(58) **Field of Classification Search**  
USPC ..... D12/107, 110, 86, 87; 280/28, 37.7,  
280/183–185, DIG. 5; D15/30; 180/908,  
180/233, 315

See application file for complete search history.

(56) **References Cited**

U.S. PATENT DOCUMENTS

D467,200	S	*	12/2002	Luo et al.	.....	D12/87
D610,514	S	*	2/2010	Eck	.....	D12/196
D636,704	S	*	4/2011	Yoo et al.	.....	D12/1
D665,305	S	*	8/2012	Eck	.....	D12/14
D682,738	S	*	5/2013	Li et al.	.....	D12/14
2010/0155170	A1	*	6/2010	Melvin et al.	.....	180/339
2012/0193163	A1	*	8/2012	Wimpfheimer et al.	.....	180/233

\* cited by examiner

*Primary Examiner* — Susan E Krakower

*Assistant Examiner* — Linda Brooks

(74) *Attorney, Agent, or Firm* — Wolf, Greenfield & Sacks, P.C.

(57) **CLAIM**

The ornamental design for an all terrain vehicle, as shown and described.

**DESCRIPTION**

FIG. 1 is a front view of an all-terrain vehicle according to the present application;  
FIG. 2 is a rear view of the all-terrain vehicle according to the present application;  
FIG. 3 is a left view of the all-terrain vehicle according to the present application;  
FIG. 4 is a right view of the all-terrain vehicle according to the present application; and,  
FIG. 5 is a top view of the all-terrain vehicle according to the present application.

**1 Claim, 5 Drawing Sheets**

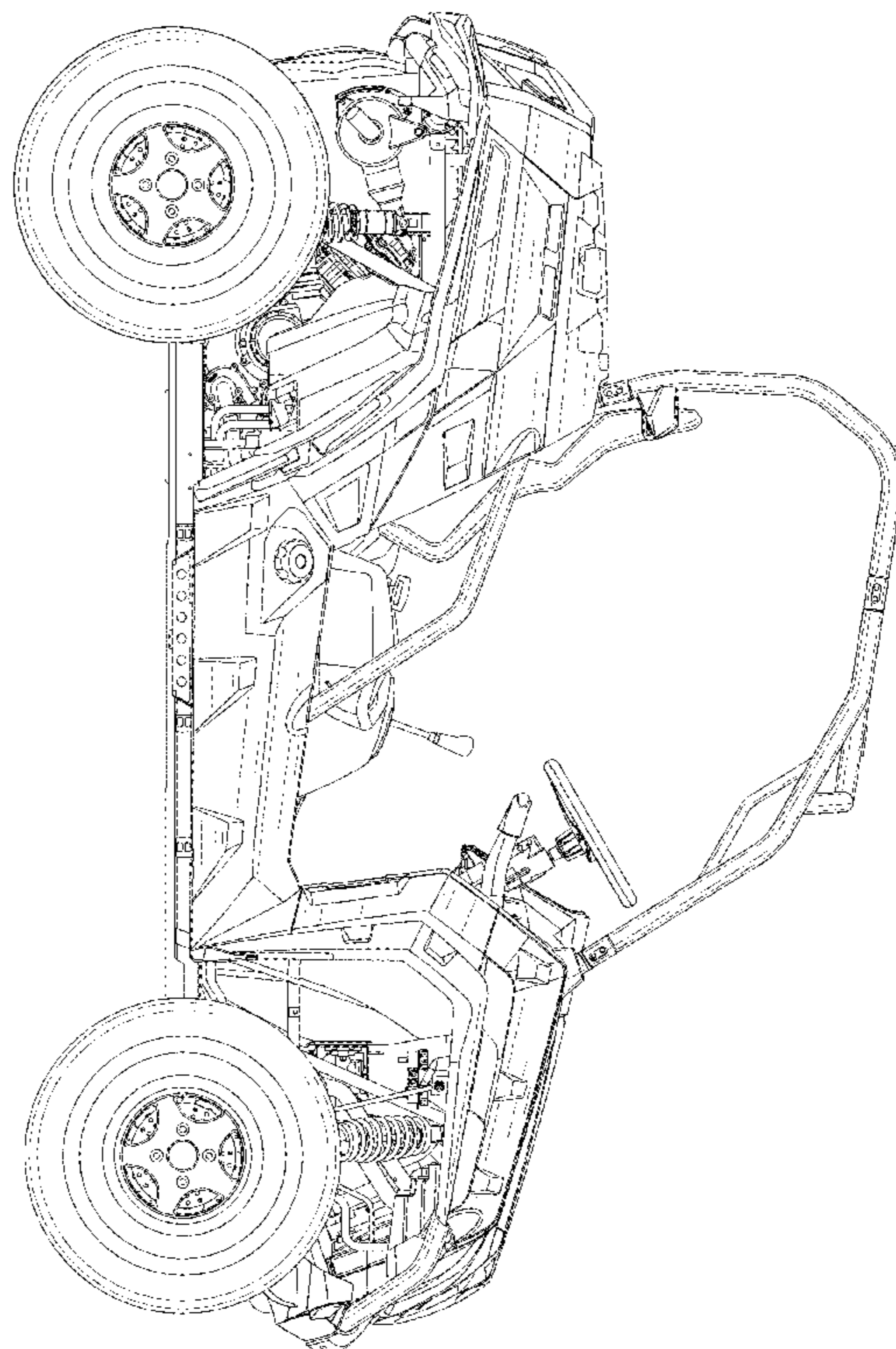
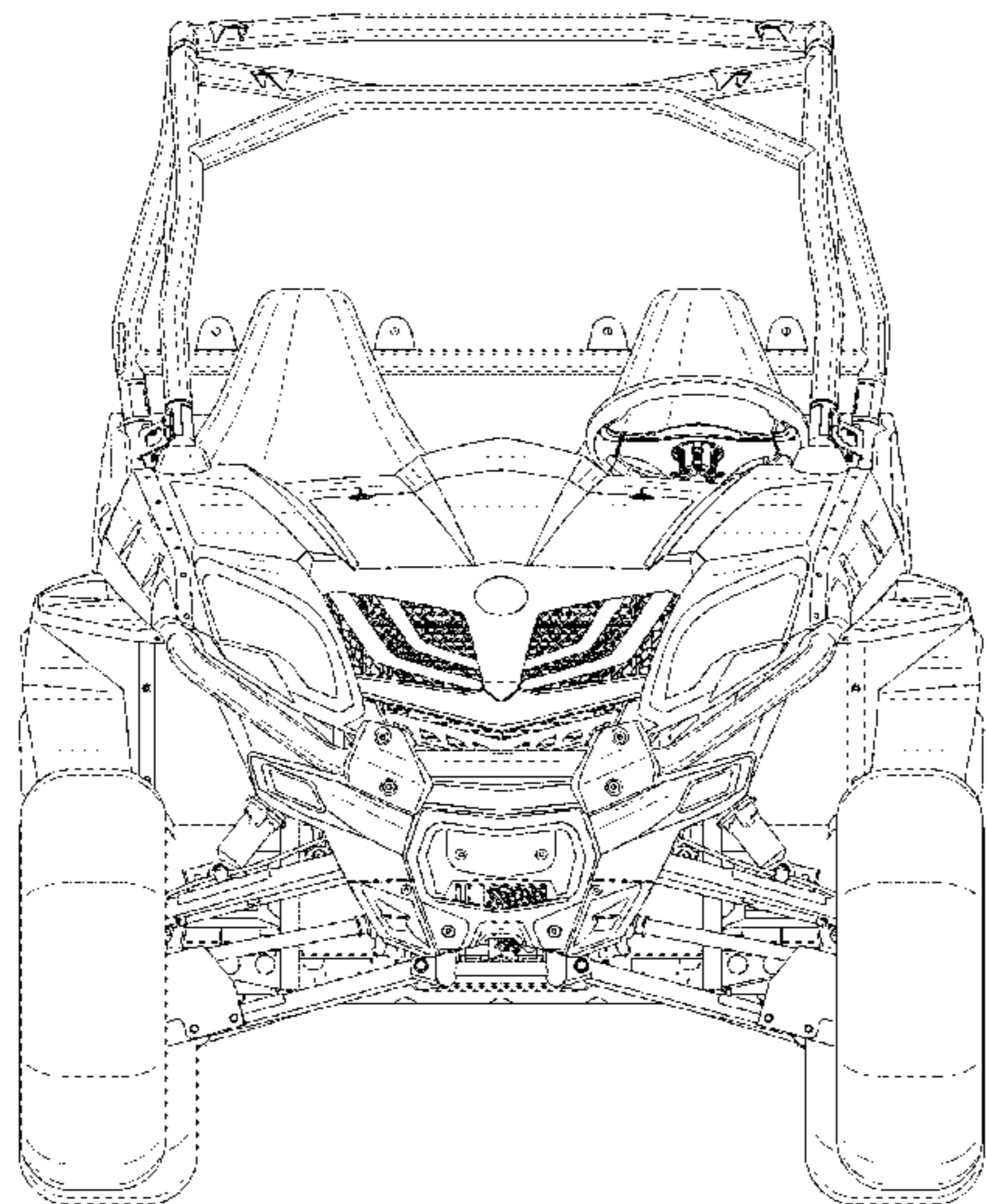

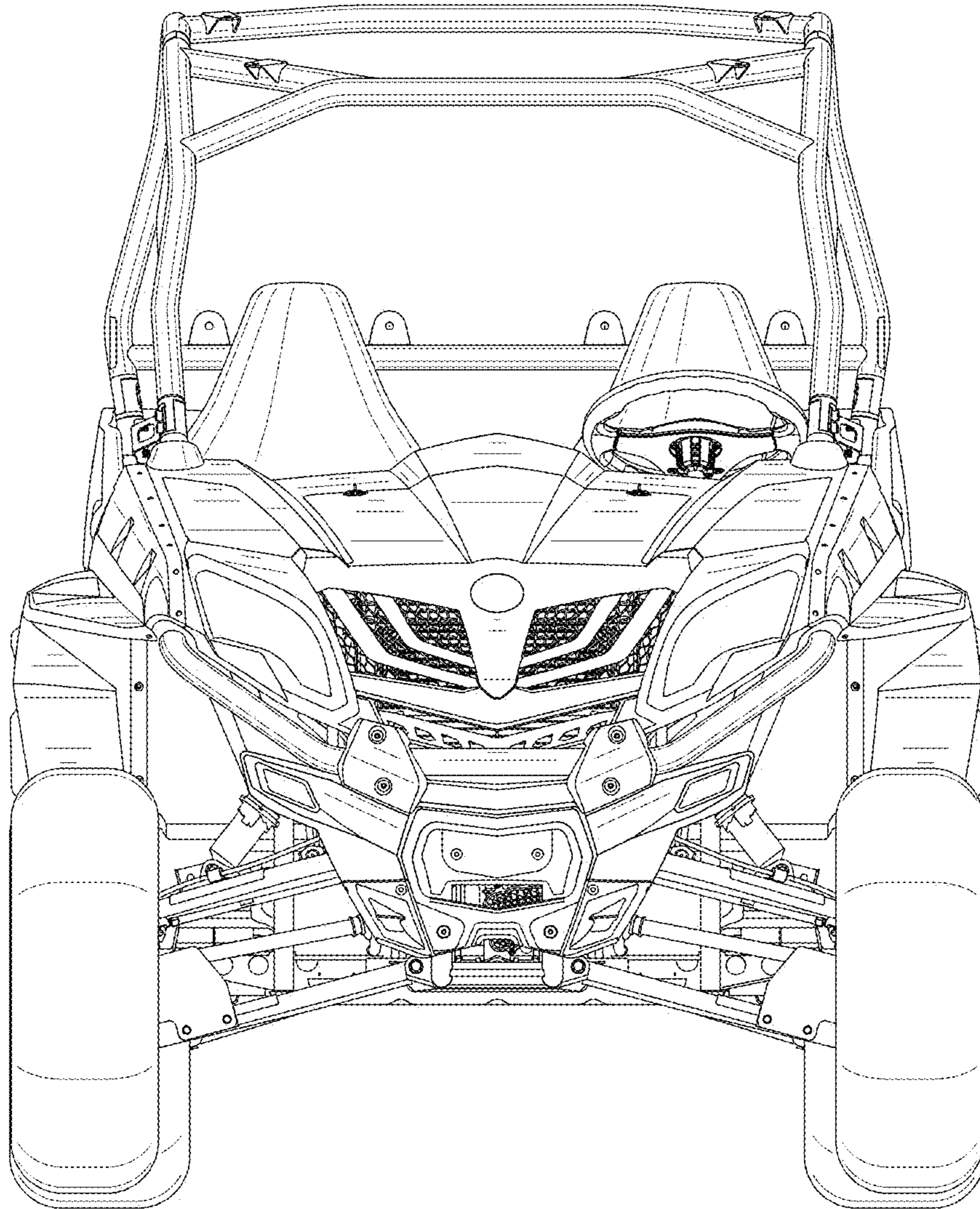

FIG. 1

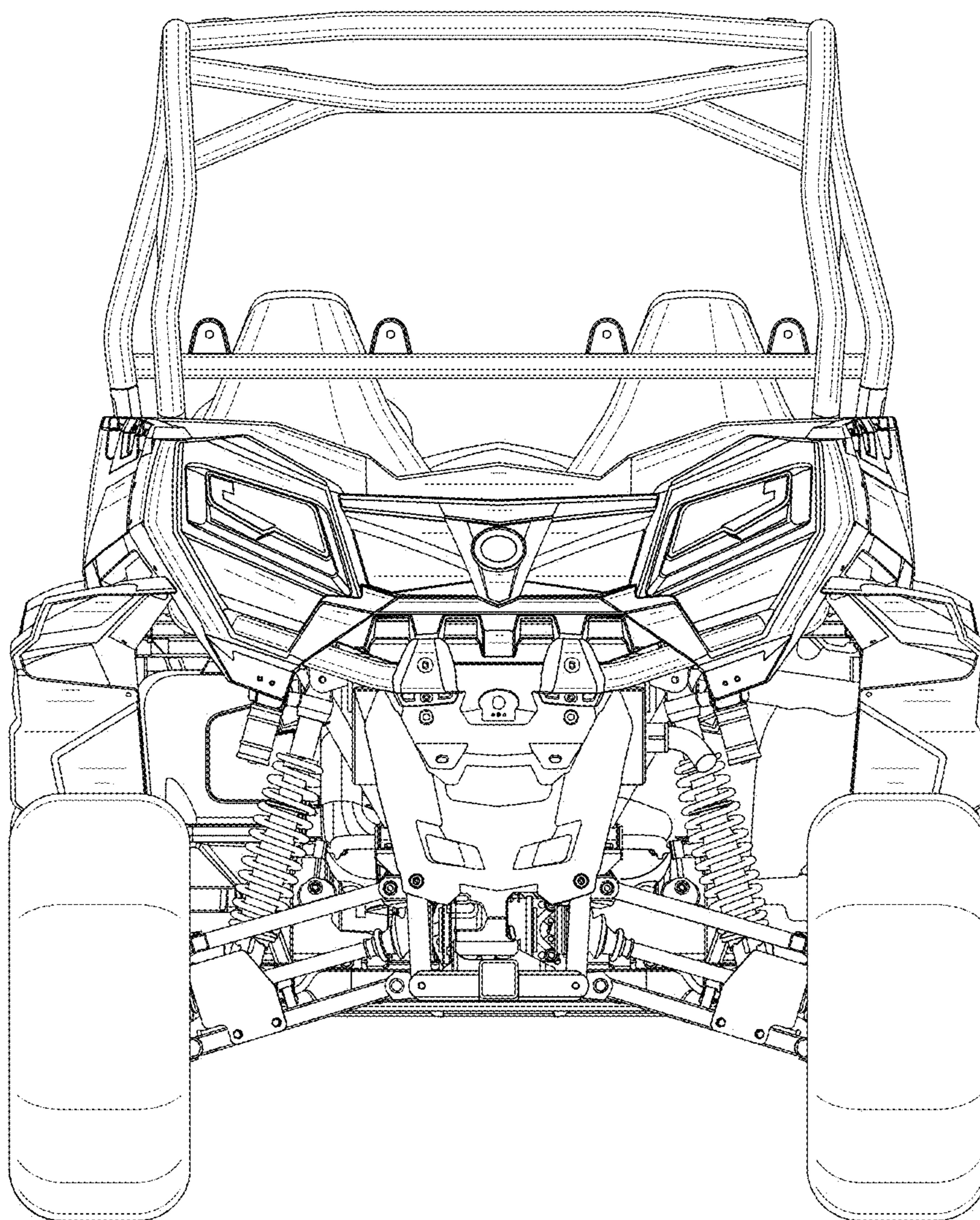

FIG. 2

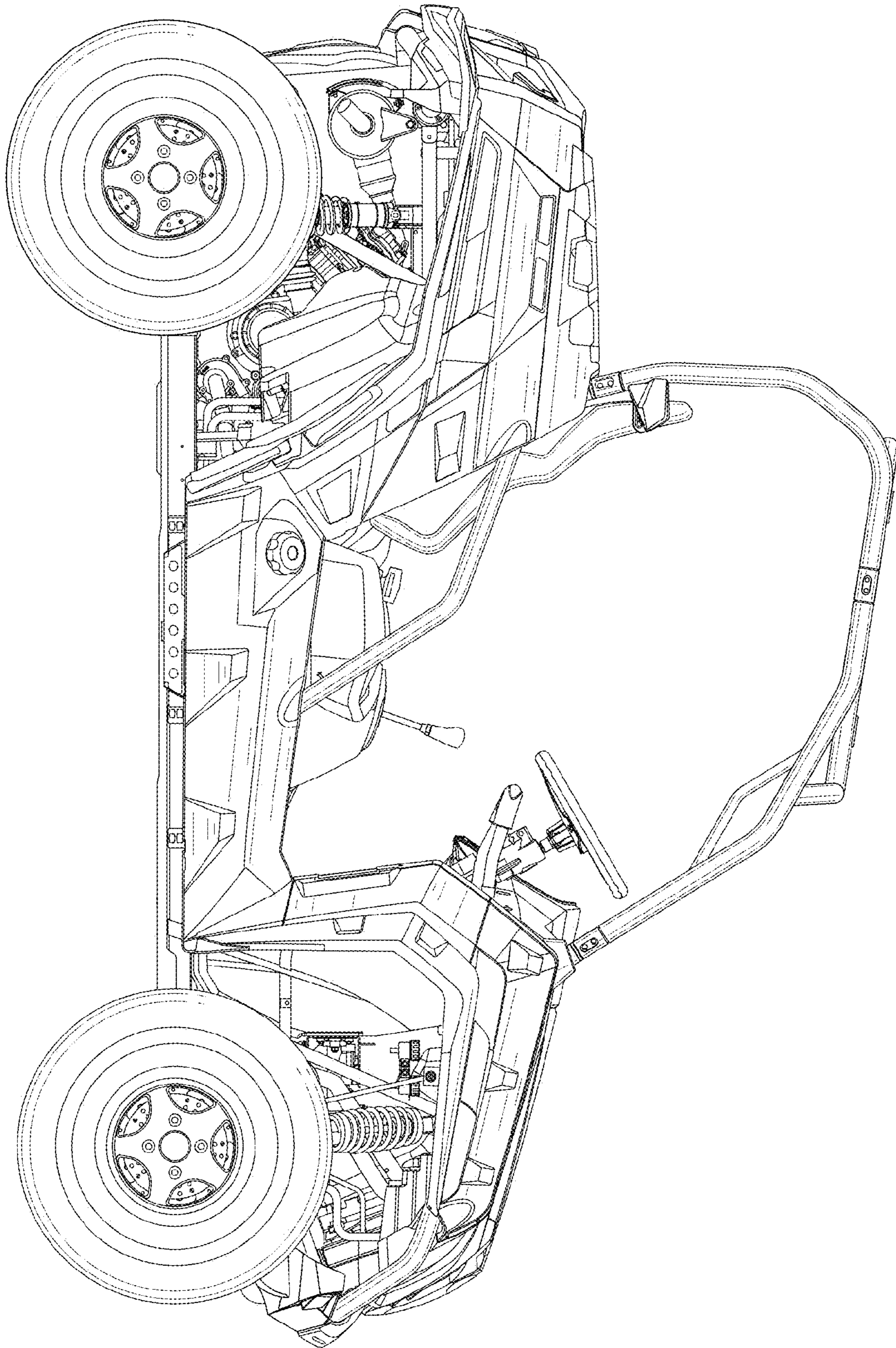

FIG. 3

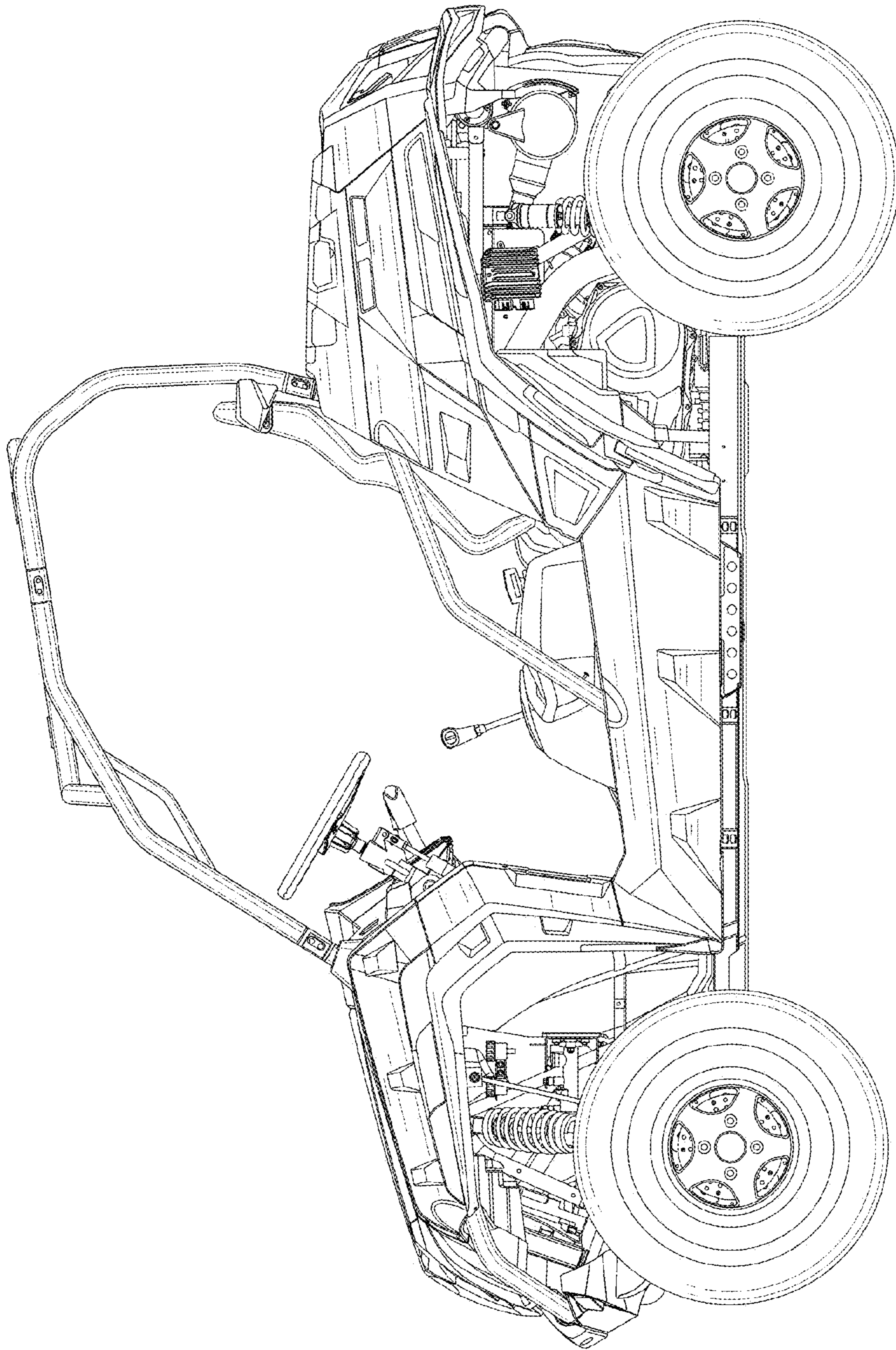

FIG. 4

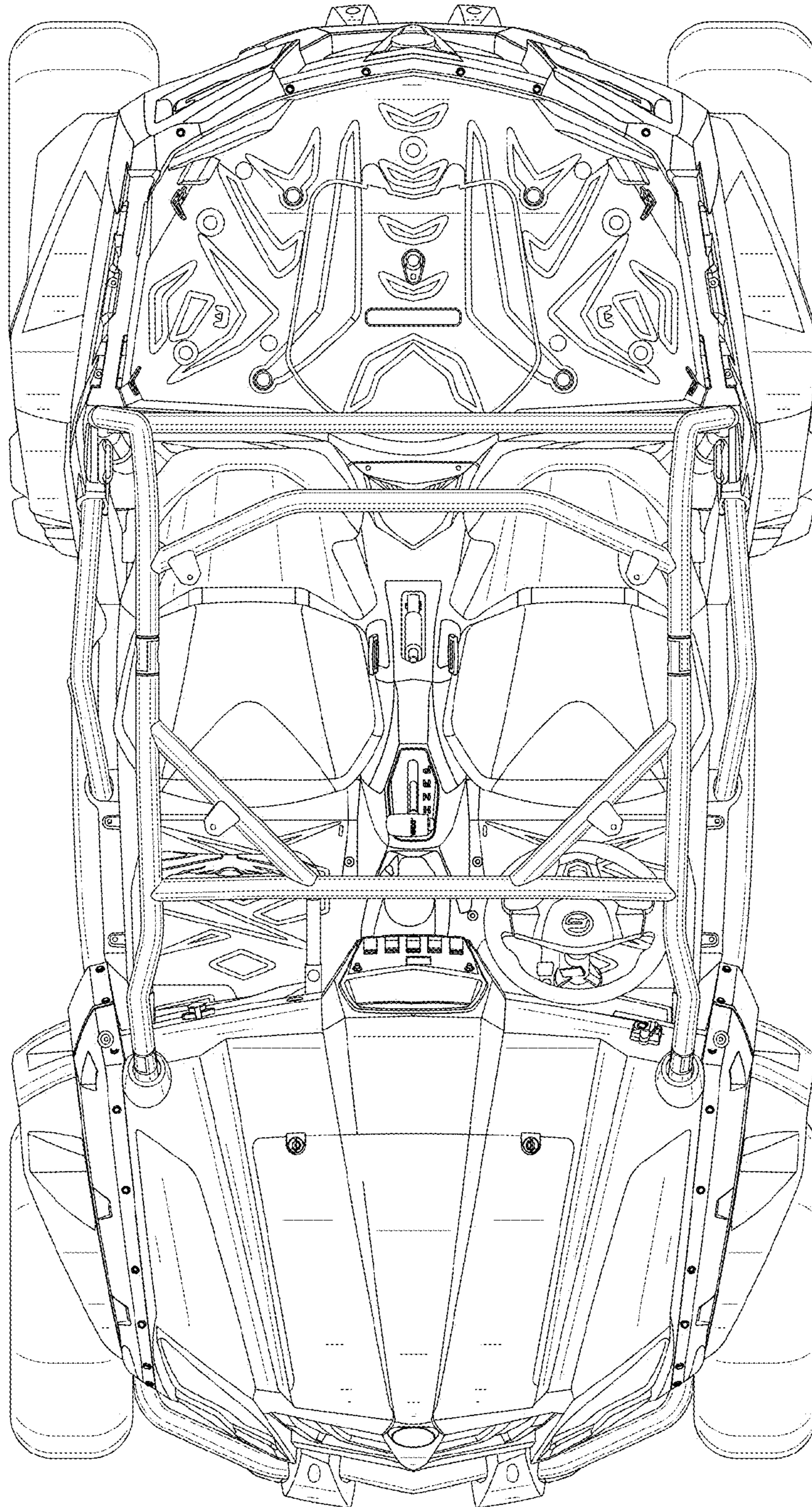

FIG. 5