



US00D701161S

(12) **United States Design Patent**  
**Yates et al.**

(10) **Patent No.:** **US D701,161 S**  
(45) **Date of Patent:** **\*\* Mar. 18, 2014**

(54) **CYCLIC AND COLLECTIVE CONTROLS**

(71) Applicant: **Bell Helicopter Textron Inc.**, Fort Worth, TX (US)

(72) Inventors: **Travis L. Yates**, Lakeside, TX (US);  
**Bradley D. Linton**, Mansfield, TX (US);  
**Chad R. Haugeberg**, Arlington, TX (US)

(73) Assignee: **Bell Helicopter Textron Inc.**, Fort Worth, TX (US)

(\*\*) Term: **14 Years**

(21) Appl. No.: **29/447,394**

(22) Filed: **Mar. 3, 2013**

(51) **LOC (10) Cl.** ..... **12-07**

(52) **U.S. Cl.**  
USPC ..... **D12/345**

(58) **Field of Classification Search**  
USPC ..... D12/16.1, 319, 326-329, 331-334,  
D12/337-339, 344, 345, 400, 415, 421,  
D12/423-425, 192; D14/405, 412-416;  
D21/324, 333, 477, 566, 430,  
D21/436-453; 273/148 B; 244/2, 5, 6, 7 A,  
244/7 R, 7 C, 8, 12.1-12.4, 17.11, 17.13,  
244/17.19, 17.23, 17.25, 17.27, 60, 99.1,  
244/117 R, 118.5, 119, 221-223, 234;  
74/471 XY, 491; 318/574, 584, 585,  
318/675; 345/156, 161; 463/36-38;  
296/37.8; D15/28

See application file for complete search history.

(56) **References Cited**

**U.S. PATENT DOCUMENTS**

4,012,014 A \* 3/1977 Marshall ..... 244/234  
4,130,259 A \* 12/1978 Carlson et al. .... 244/234  
4,584,510 A \* 4/1986 Hollow ..... 318/584  
4,865,277 A \* 9/1989 Smith et al. .... 244/234

4,887,782 A \* 12/1989 Carnell et al. .... 244/234  
4,895,040 A \* 1/1990 Soederberg ..... 74/491  
5,137,234 A \* 8/1992 Sakurai ..... 244/234  
5,149,023 A \* 9/1992 Sakurai et al. .... 244/229  
5,156,363 A \* 10/1992 Cizewski et al. .... 244/223  
5,456,428 A \* 10/1995 Hegg ..... 244/229  
5,769,363 A \* 6/1998 Griswold et al. .... 244/234  
5,900,710 A \* 5/1999 Gautier et al. .... 318/675  
6,254,037 B1 \* 7/2001 Fenny et al. .... 244/223  
D462,685 S \* 9/2002 Yamamoto et al. .... D14/415  
6,631,652 B1 \* 10/2003 Okazawa et al. .... 74/471 XY  
6,682,116 B1 \* 1/2004 Okumura ..... 296/37.8  
D516,096 S \* 2/2006 Bergman et al. .... D15/28  
D581,861 S \* 12/2008 Anttila et al. .... D12/421

(Continued)

*Primary Examiner* — Caron D Veynar  
*Assistant Examiner* — Martie K Holtje

(57) **CLAIM**

The ornamental design for cyclic and collective controls, as shown and described.

**DESCRIPTION**

FIG. 1 is a front perspective view of cyclic and collective controls showing our new design;  
FIG. 2 is a front elevational view thereof;  
FIG. 3 is a rear elevational view thereof;  
FIG. 4 is a right side elevational view thereof;  
FIG. 5 is a left side elevational view thereof;  
FIG. 6 is a top plan view thereof;  
FIG. 7 is a bottom plan view thereof; and,  
FIG. 8 is a rear perspective view thereof.

The broken line showing of structural elements is included for the purpose of illustrating portions of the cyclic and collective controls that form no part of the claimed design.

The broken lines encircling the inside and outside of the ovoid portion on the rear of the cyclic and collective controls in FIGS. 3 and 8 have been shown for the purpose of defining boundaries, the area within which forms no part of the claimed design.

**1 Claim, 8 Drawing Sheets**

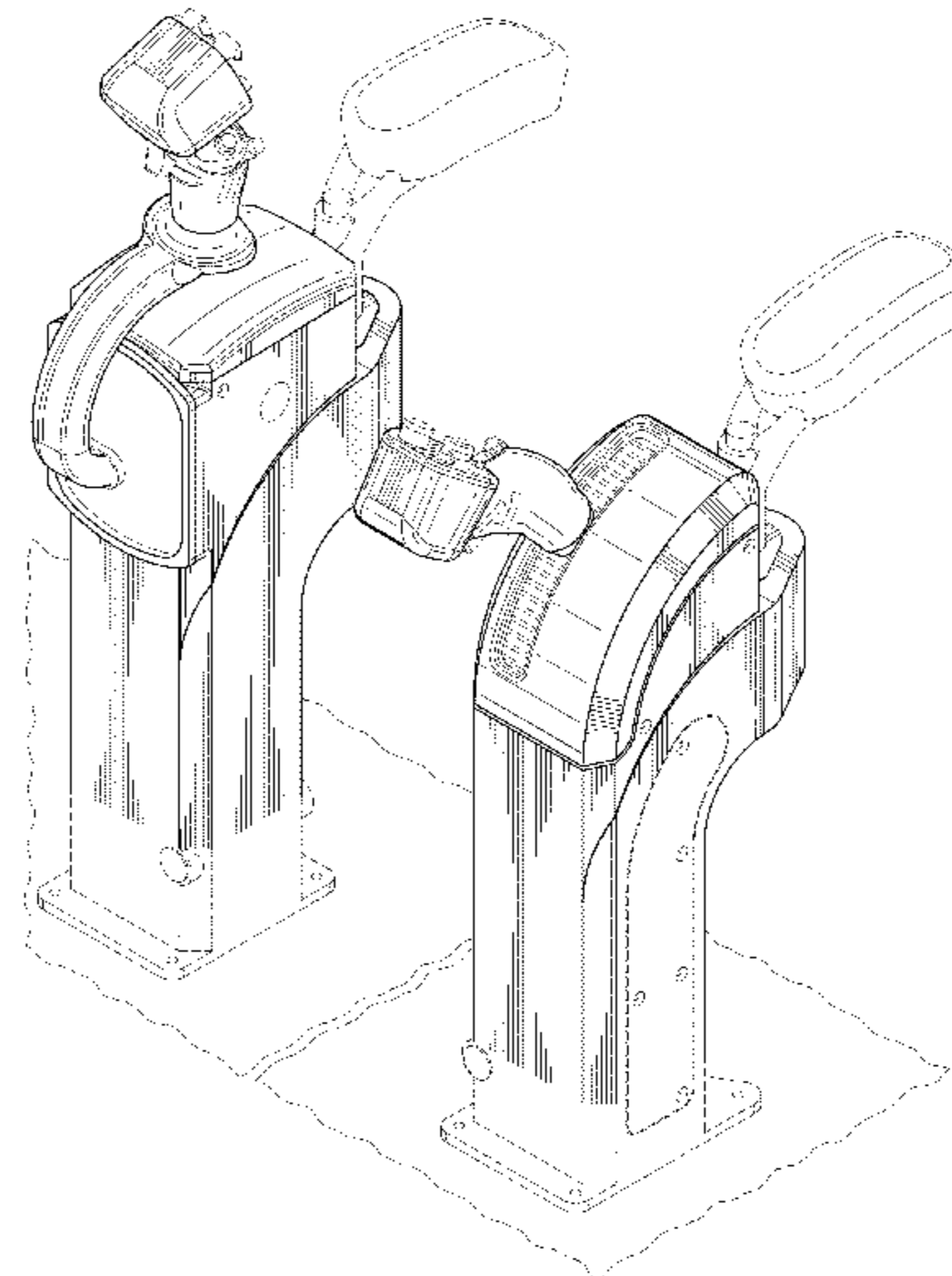
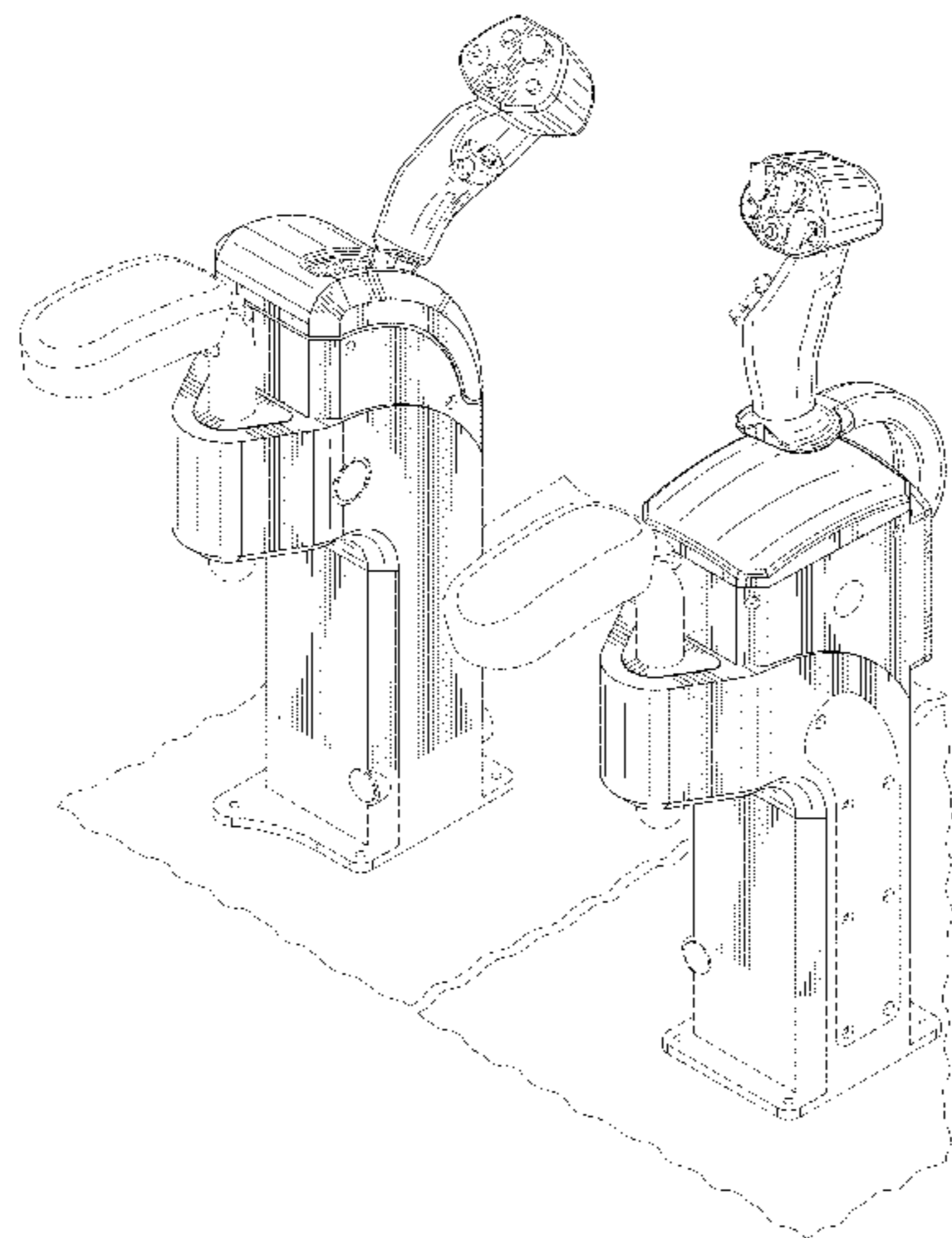

# US D701,161 S

Page 2

---

(56)

## References Cited

### U.S. PATENT DOCUMENTS

D581,862 S *	12/2008	Anttila et al. ....	D12/421	
D613,232 S *	4/2010	Guering .....	D12/345	* cited by examiner
D613,668 S *	4/2010	Guering .....	D12/345	
2009/0139360 A1 *	6/2009	Diccion .....	74/471 XY	
2009/0230252 A1 *	9/2009	Daunois et al. ....	244/234	

FIG. 1

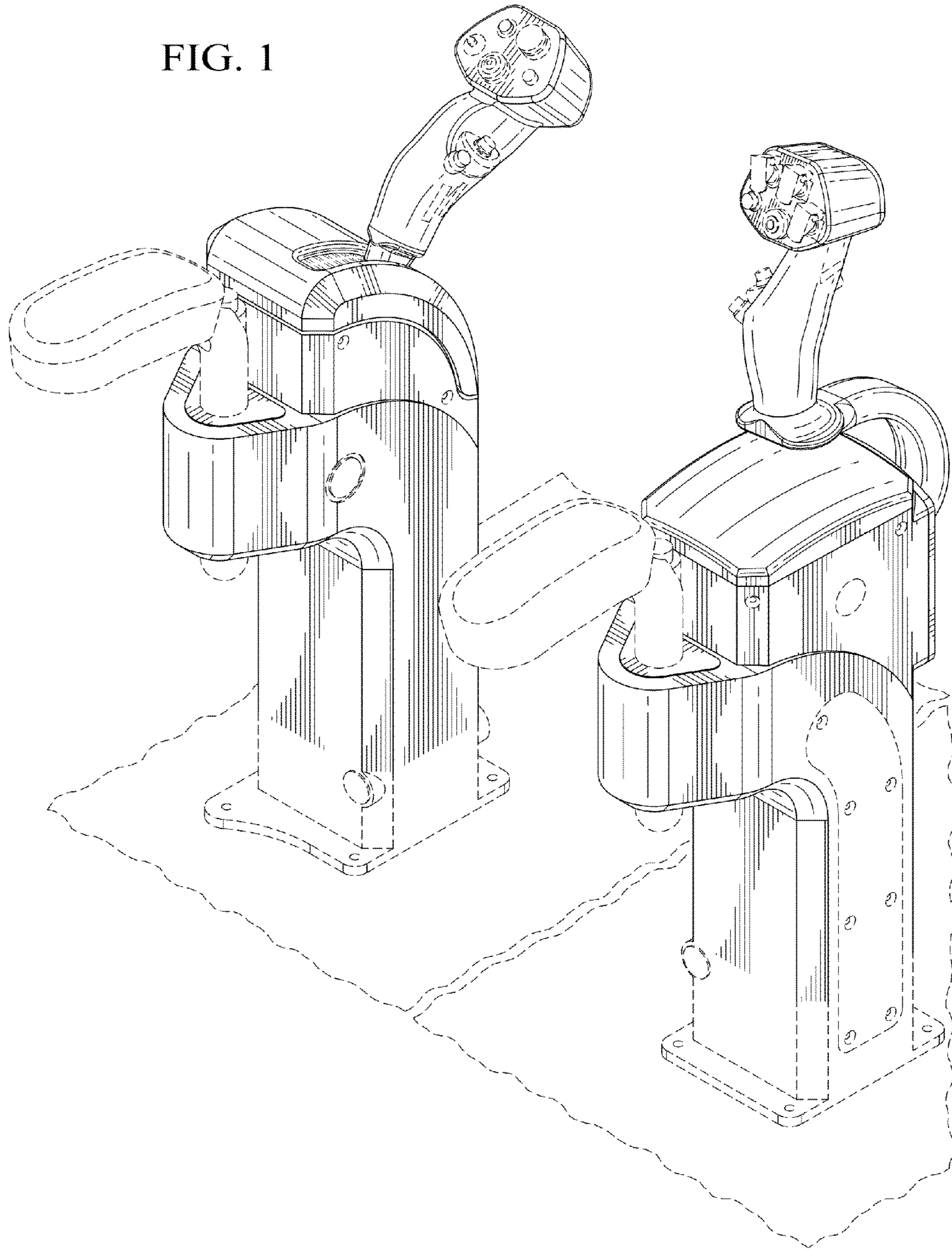
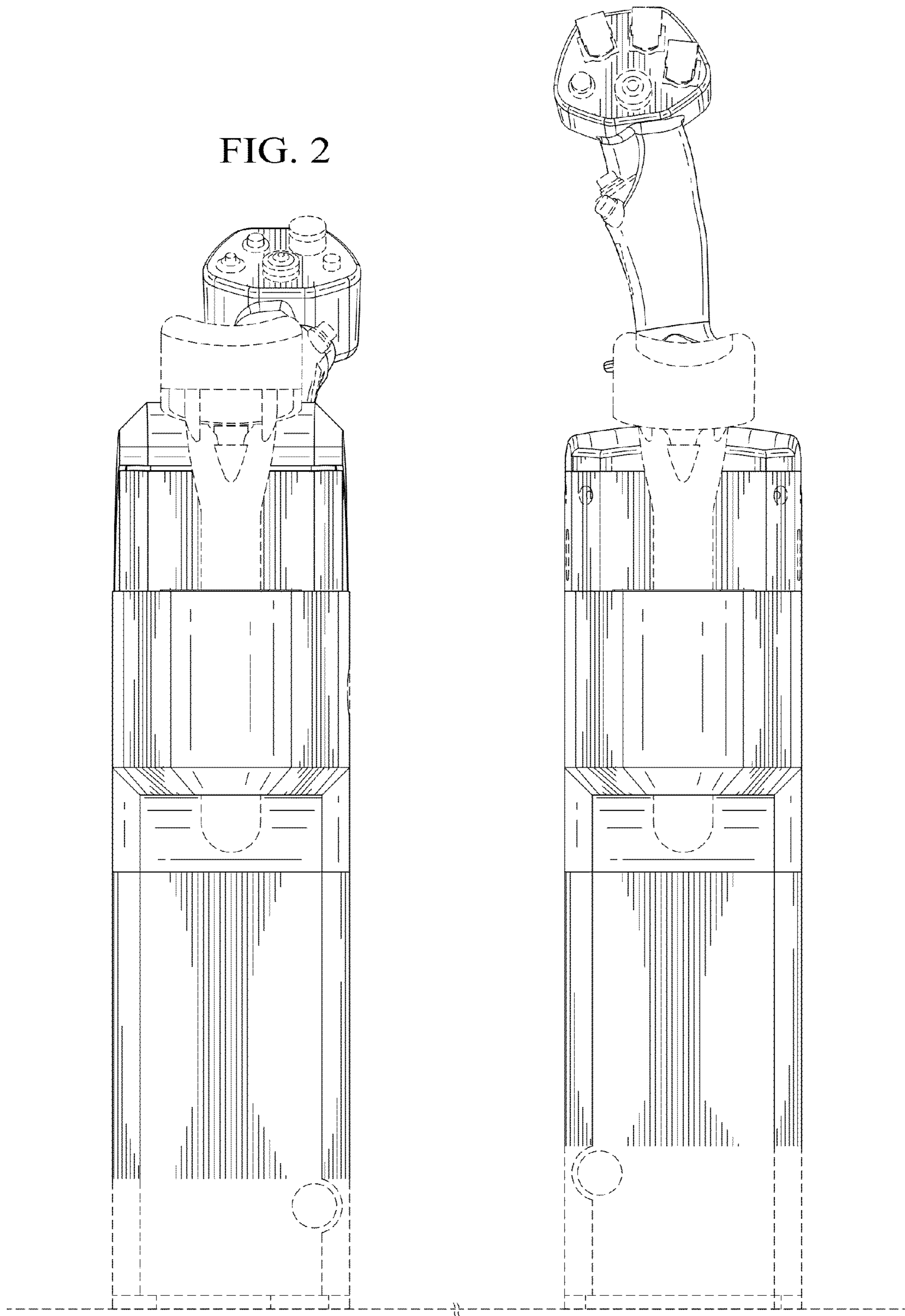

FIG. 2



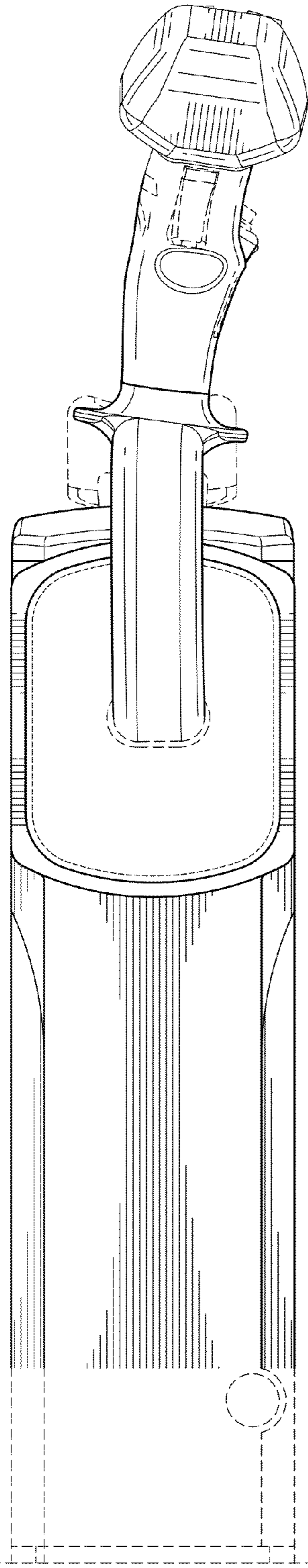

FIG. 3

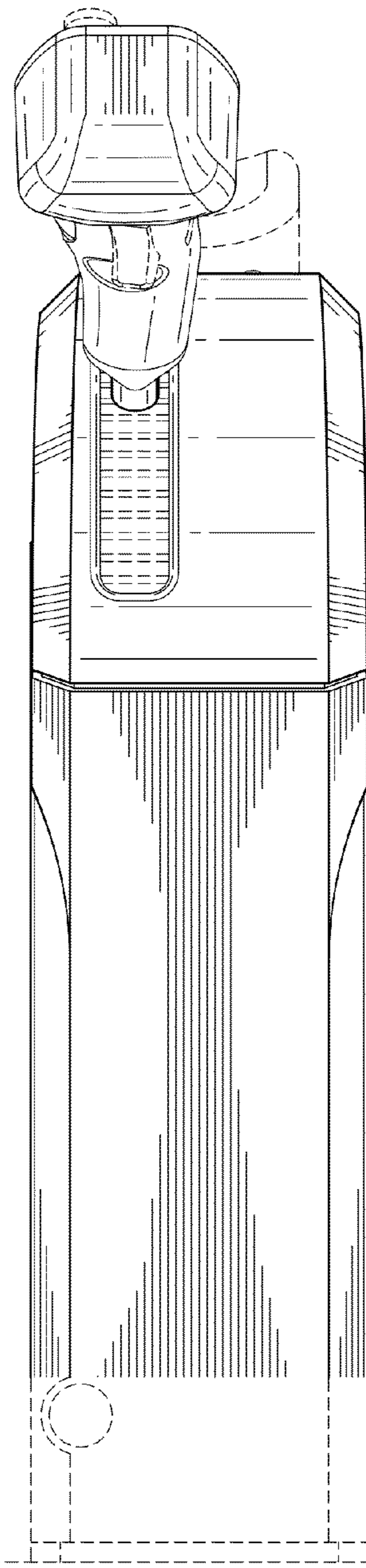
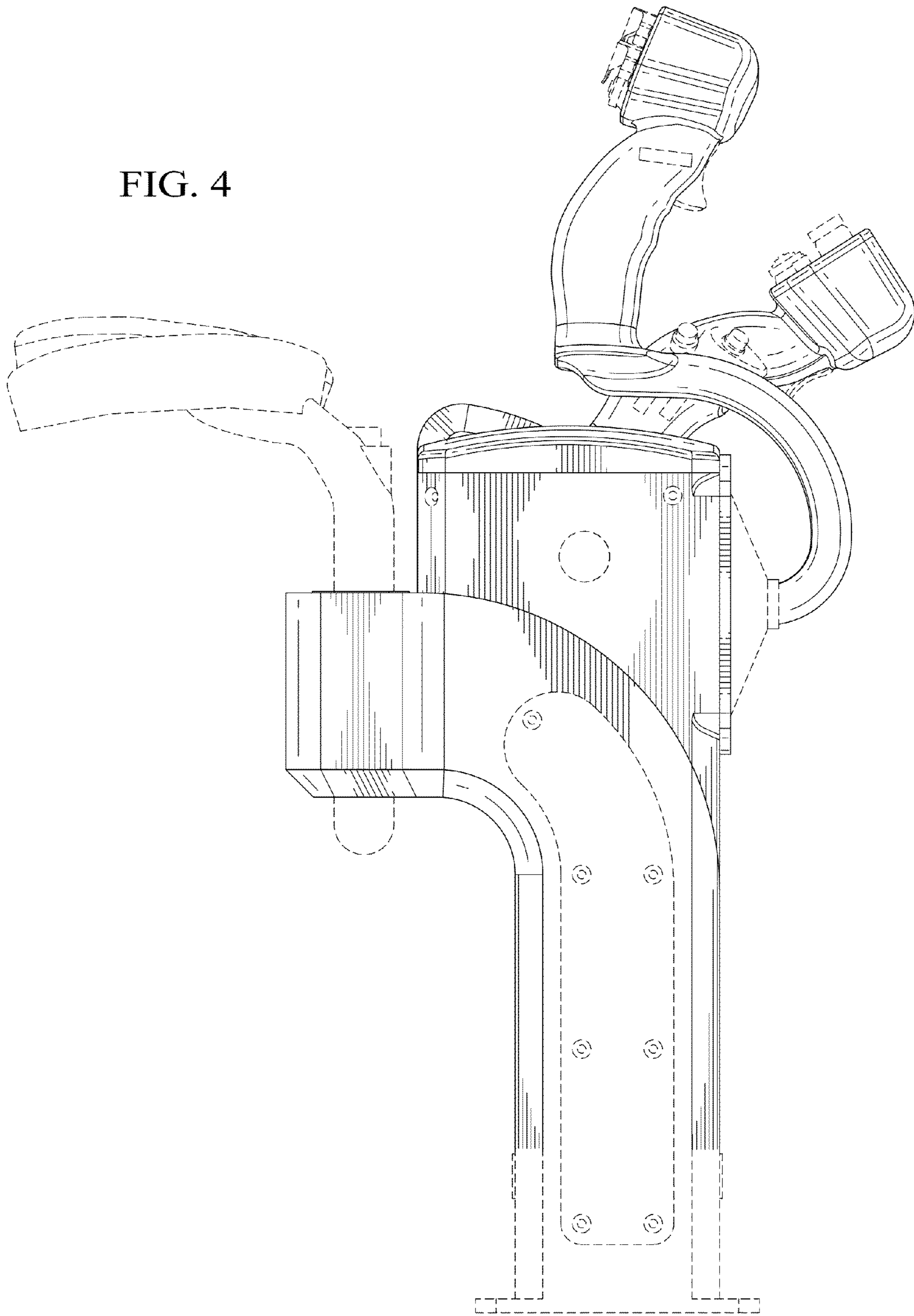

FIG. 4



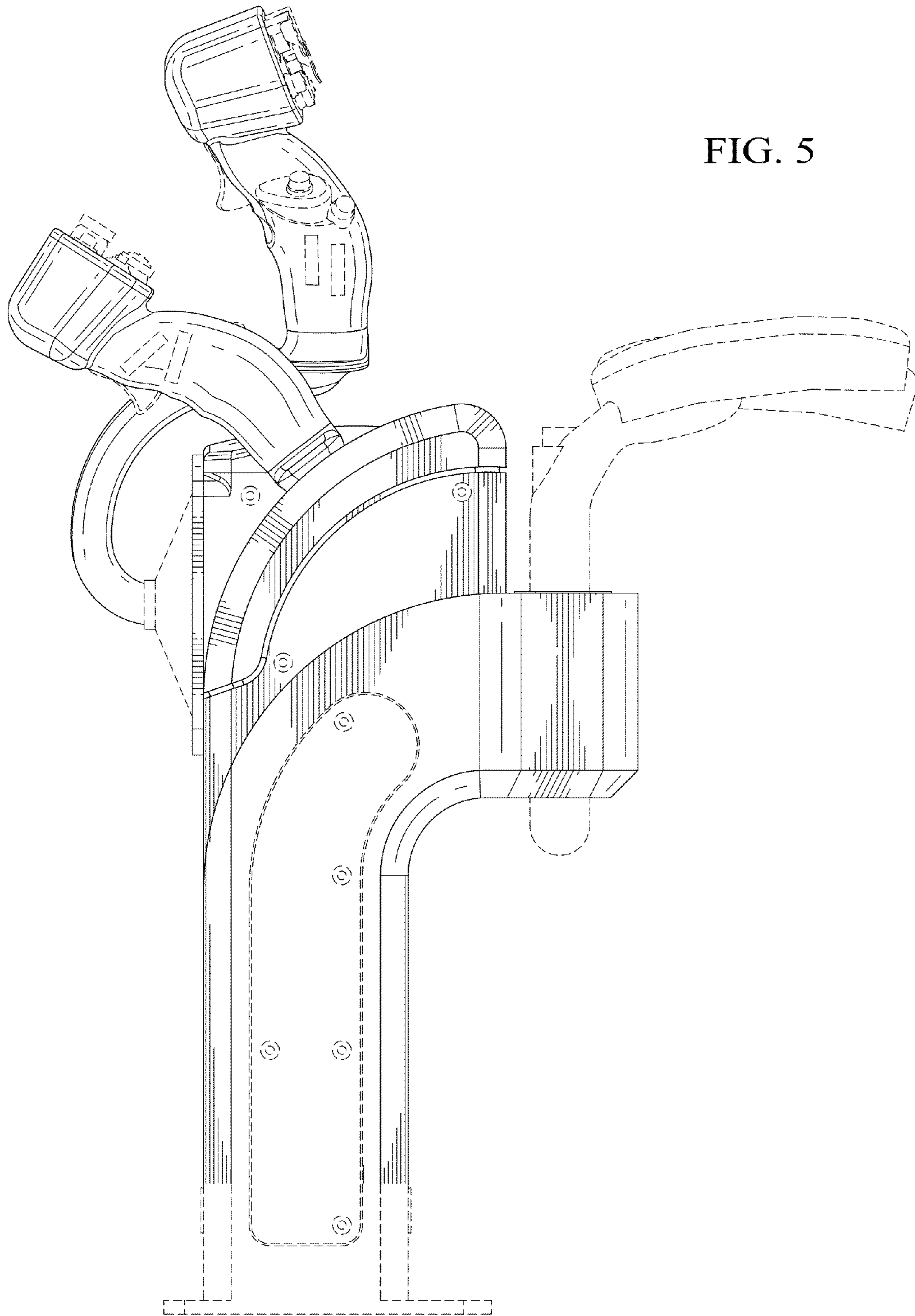

FIG. 5

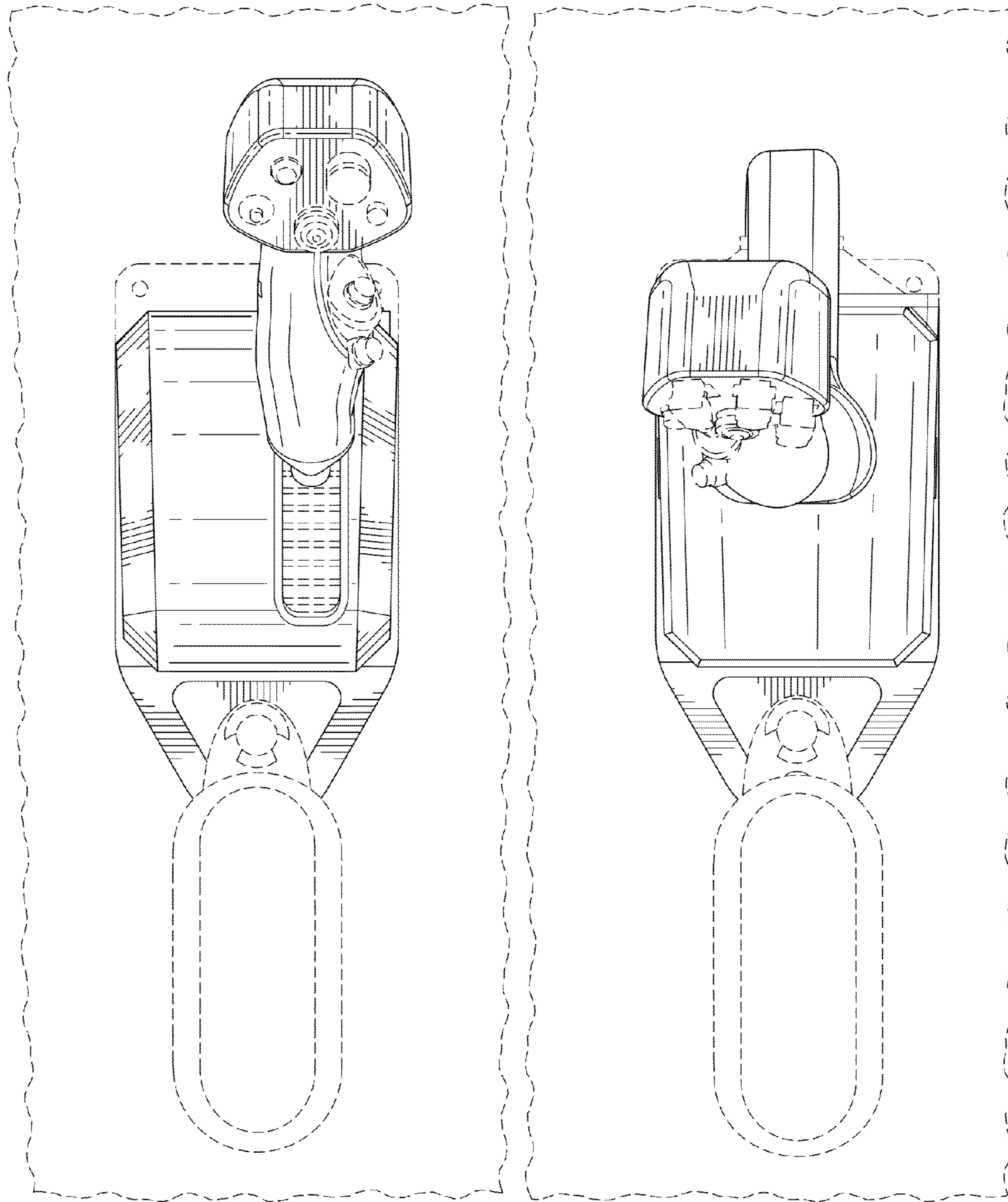

FIG. 6



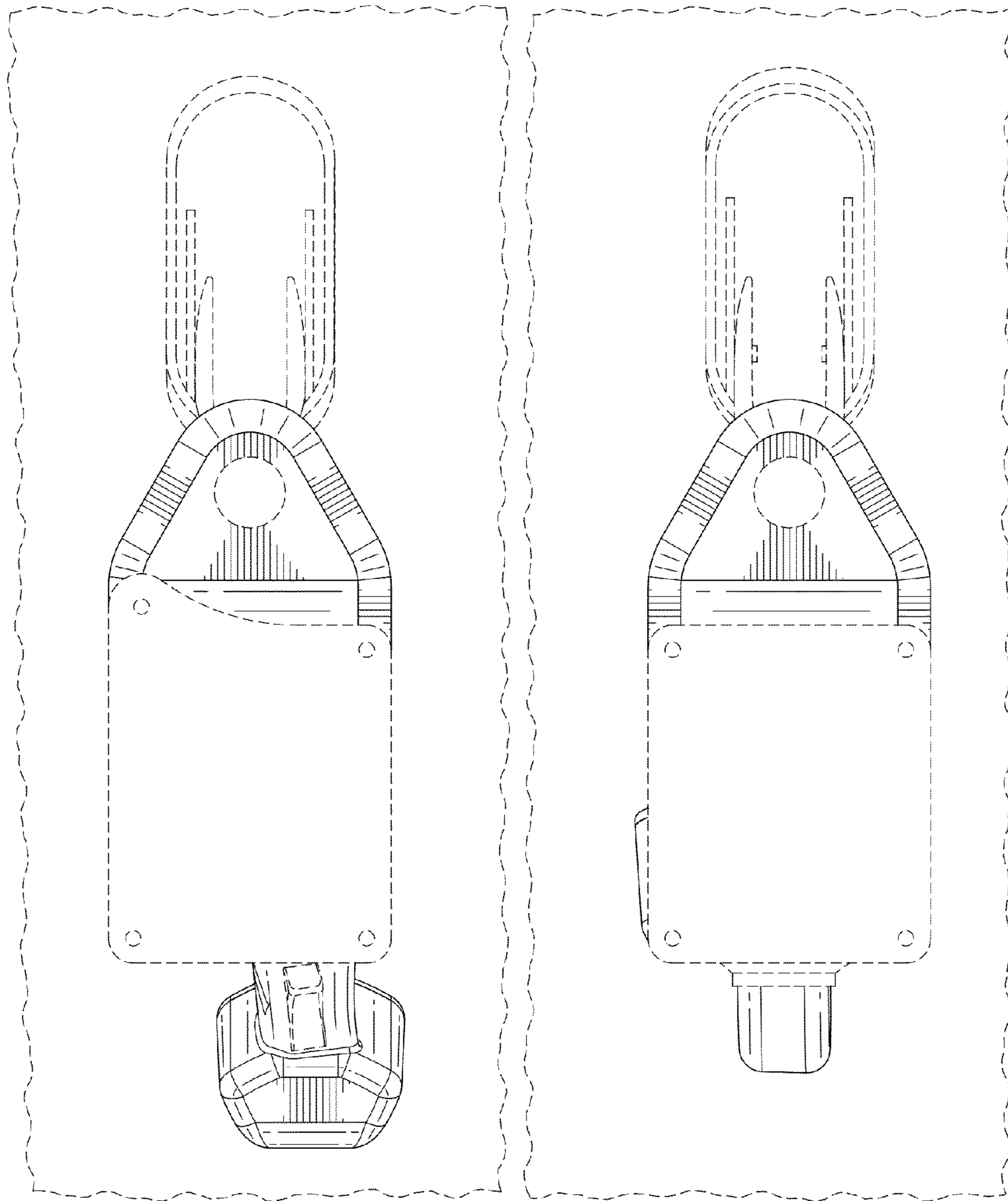

FIG. 7

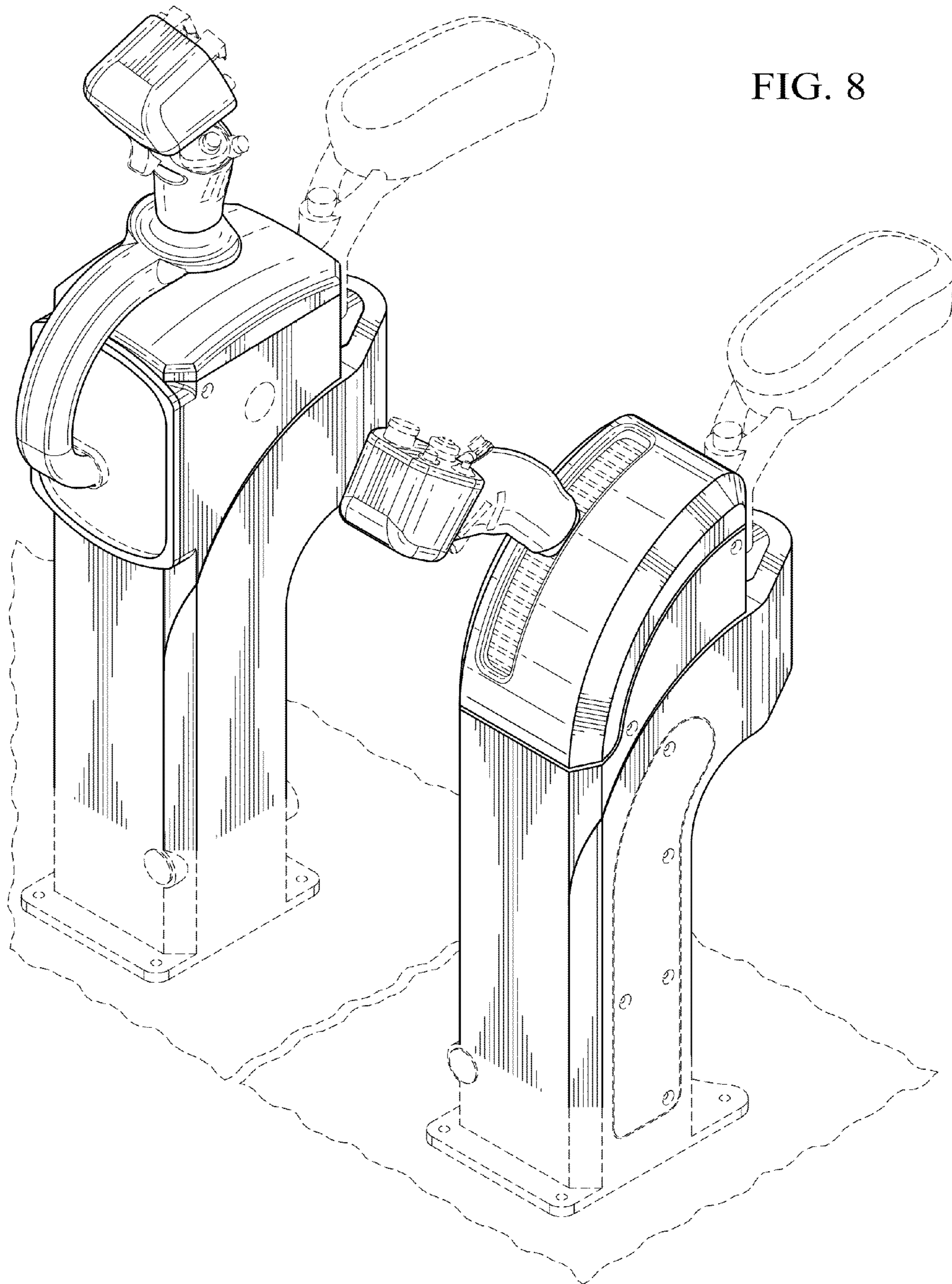

FIG. 8