



US00D701160S

(12) **United States Design Patent**
Boon

(10) **Patent No.:** **US D701,160 S**
(45) **Date of Patent:** **** Mar. 18, 2014**

- (54) **BOAT**
- (75) Inventor: **Dennis Boon**, Walton on Thames (GB)
- (73) Assignee: **Circraft Speed Boats, LLC**, Fort Lauderdale, FL (US)
- (**) Term: **14 Years**
- (21) Appl. No.: **29/408,040**
- (22) Filed: **Dec. 6, 2011**
- (51) **LOC (10) Cl.** **12-06**
- (52) **U.S. Cl.**
USPC **D12/300**
- (58) **Field of Classification Search**
USPC D12/300-318; D21/542-547, 801;
114/56.1, 152, 183, 345, 346, 355,
114/363; 441/67
See application file for complete search history.

D286,529 S *	11/1986	Hoyt	D12/305
4,730,572 A *	3/1988	Hollingsworth	114/283
D310,058 S *	8/1990	Thompson et al.	D12/308
D345,957 S *	4/1994	Fleurbay	D12/307
D357,222 S *	4/1995	Lunter et al.	D12/307
D382,532 S *	8/1997	Hazen	D12/306
D392,242 S *	3/1998	McCulloh	D12/316
6,543,378 B1 *	4/2003	Johnson, Sr.	114/346
6,962,124 B1 *	11/2005	North et al.	114/346

* cited by examiner

Primary Examiner — Cynthia M Chin
(74) *Attorney, Agent, or Firm* — Bay State IP, LLC

(57) **CLAIM**
I claim the ornamental design for a boat, as shown and described.

DESCRIPTION

FIG. 1 is a top side perspective view showing my new design;
FIG. 2 is a side view thereof;
FIG. 3 is a top view thereof;
FIG. 4 is a bottom view thereof;
FIG. 5 is a front view thereof; and,
FIG. 6 is a back view thereof.
The broken lines form no part of the claimed design.

1 Claim, 3 Drawing Sheets

- (56) **References Cited**
U.S. PATENT DOCUMENTS
3,452,698 A * 7/1969 Wilson 114/271
3,718,111 A * 2/1973 Vecchio 114/55.5
3,974,535 A * 8/1976 Guanzini 114/346
D284,074 S * 6/1986 Hooper D12/308

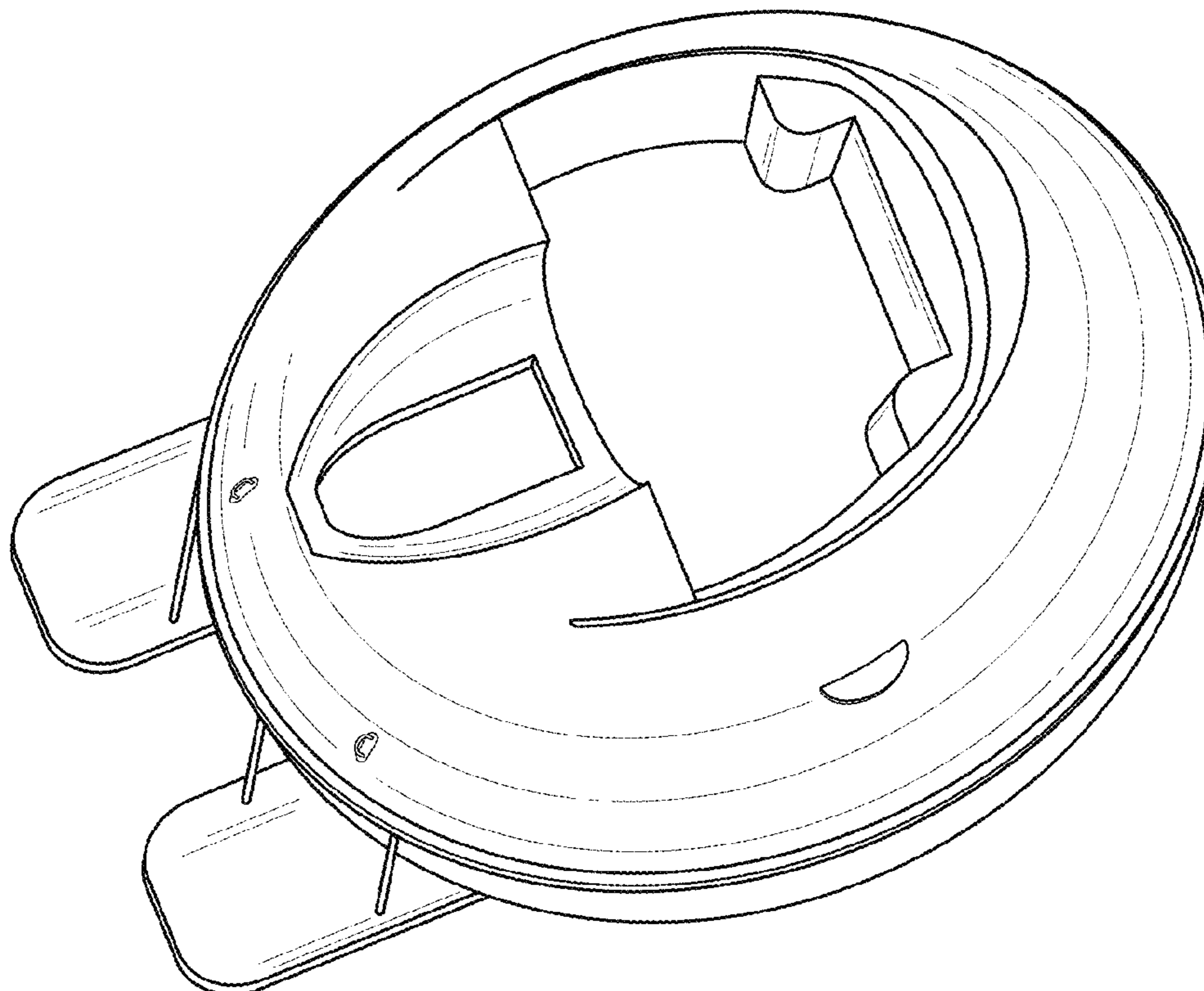

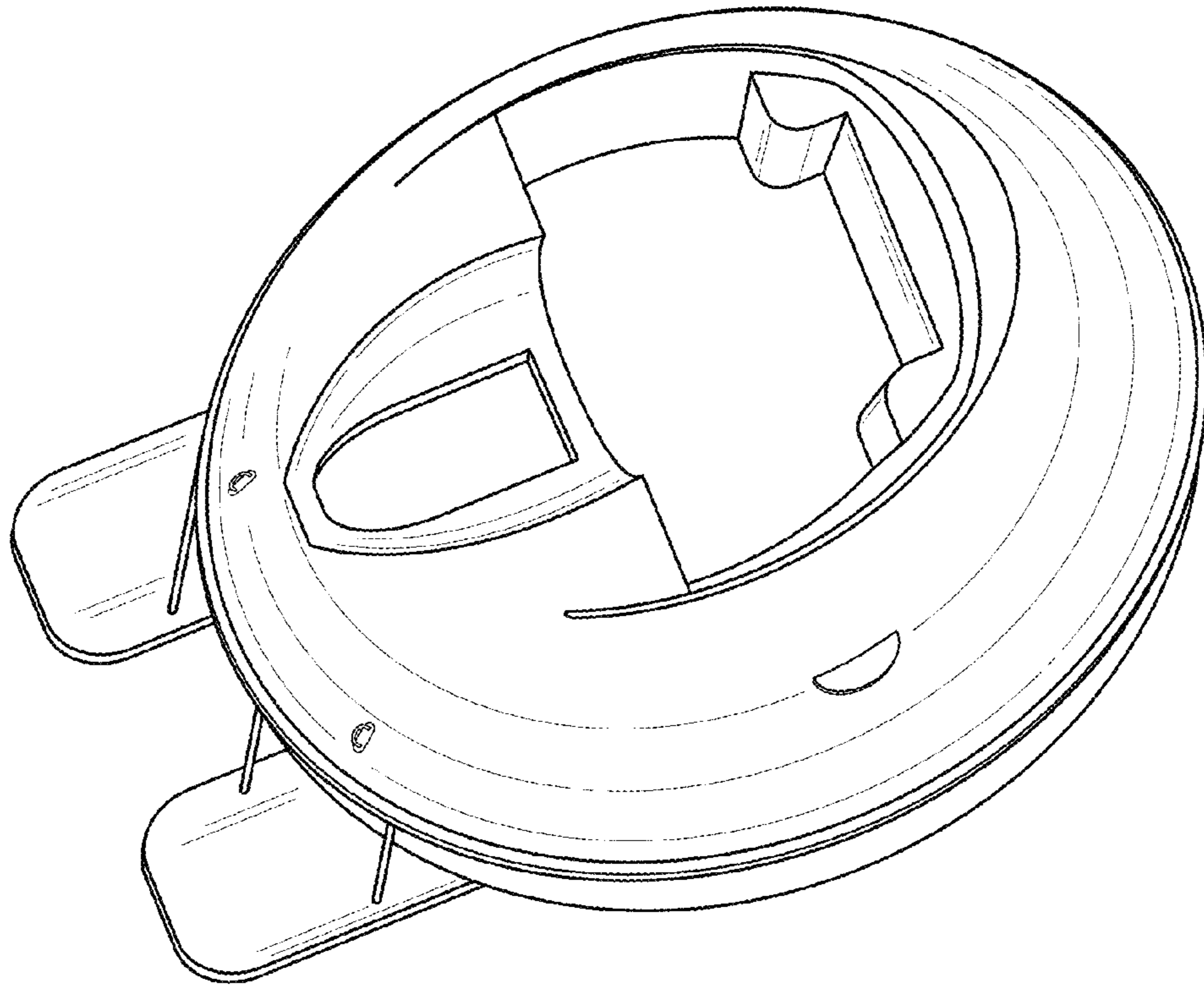

Fig. 1

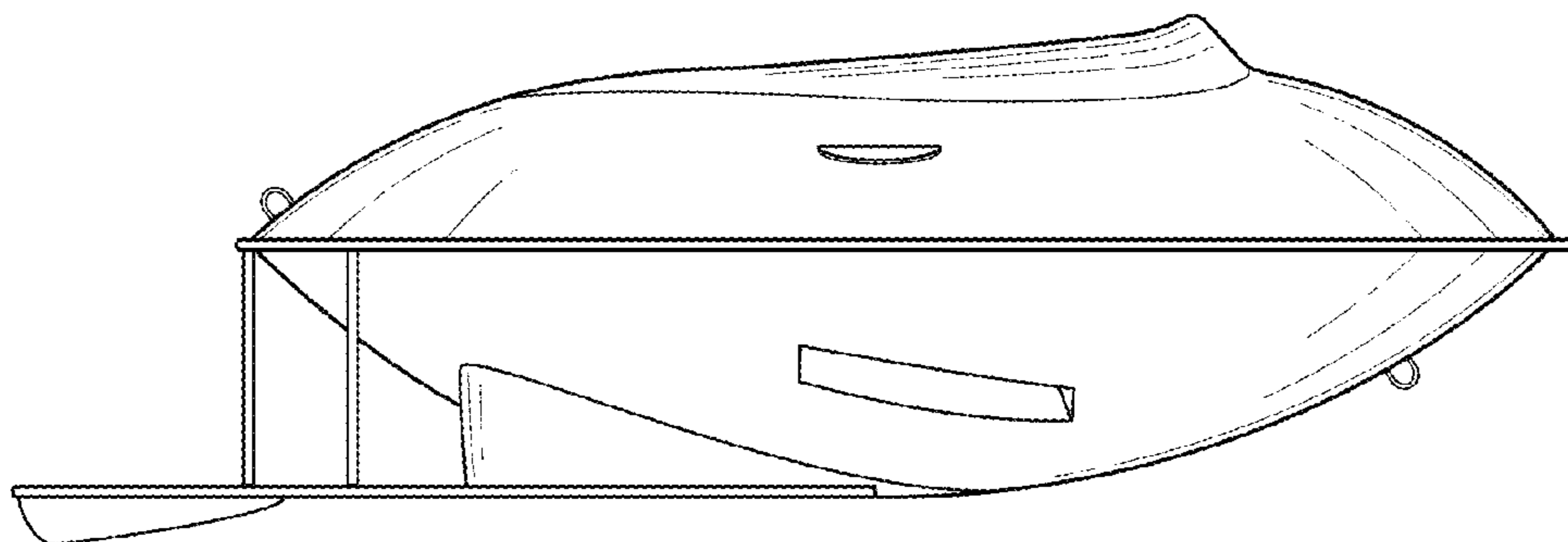

Fig. 2

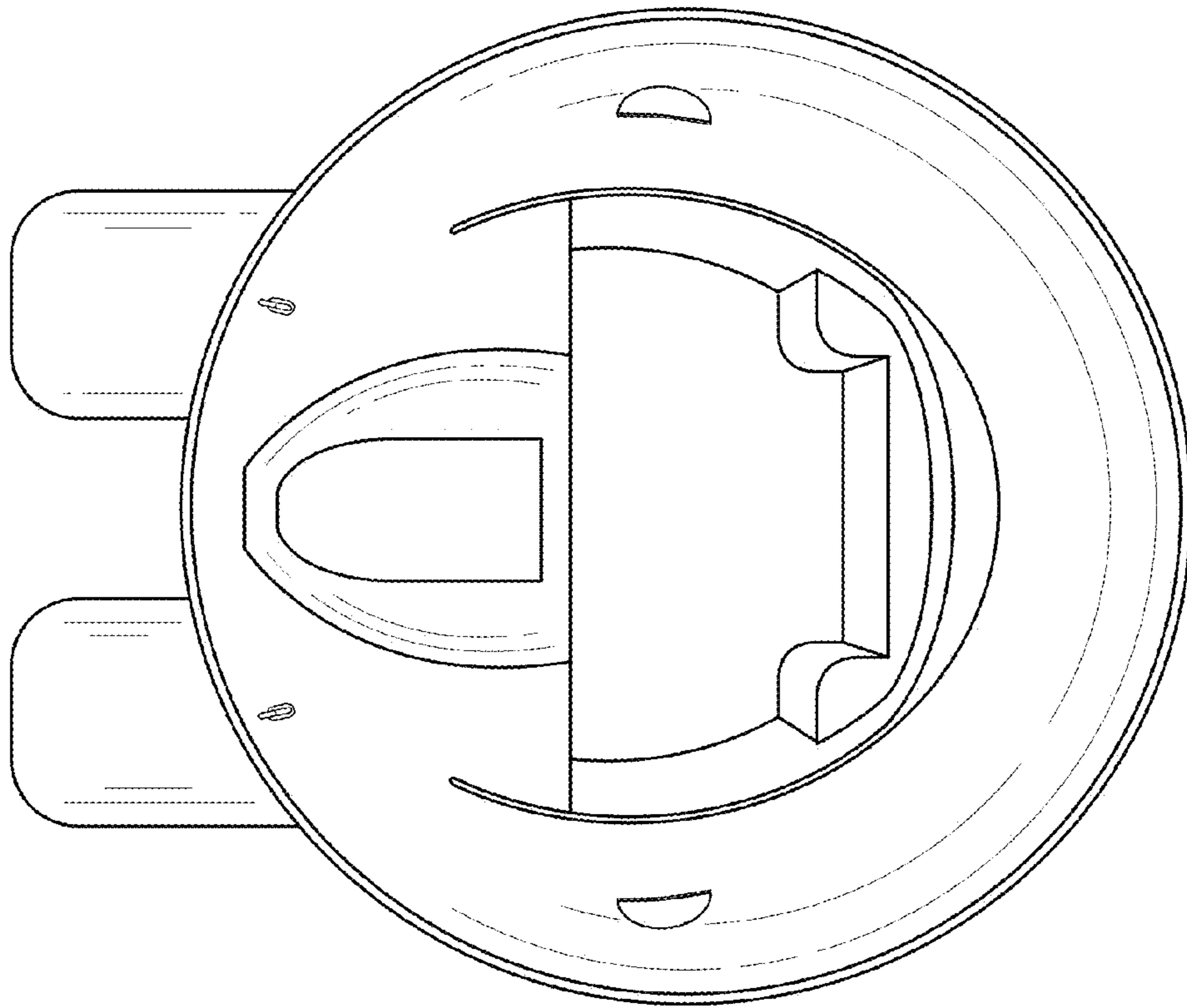

Fig. 3

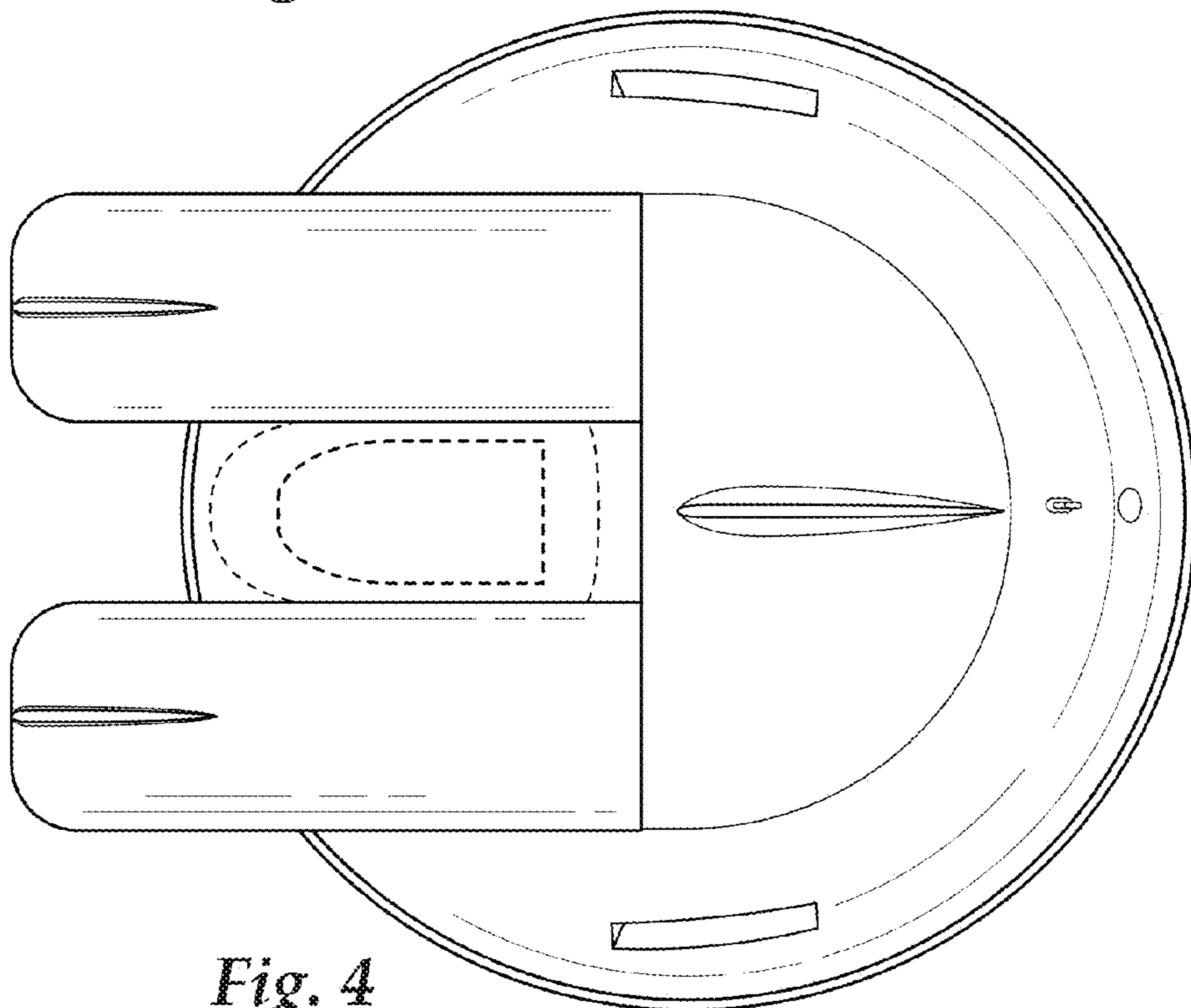

Fig. 4

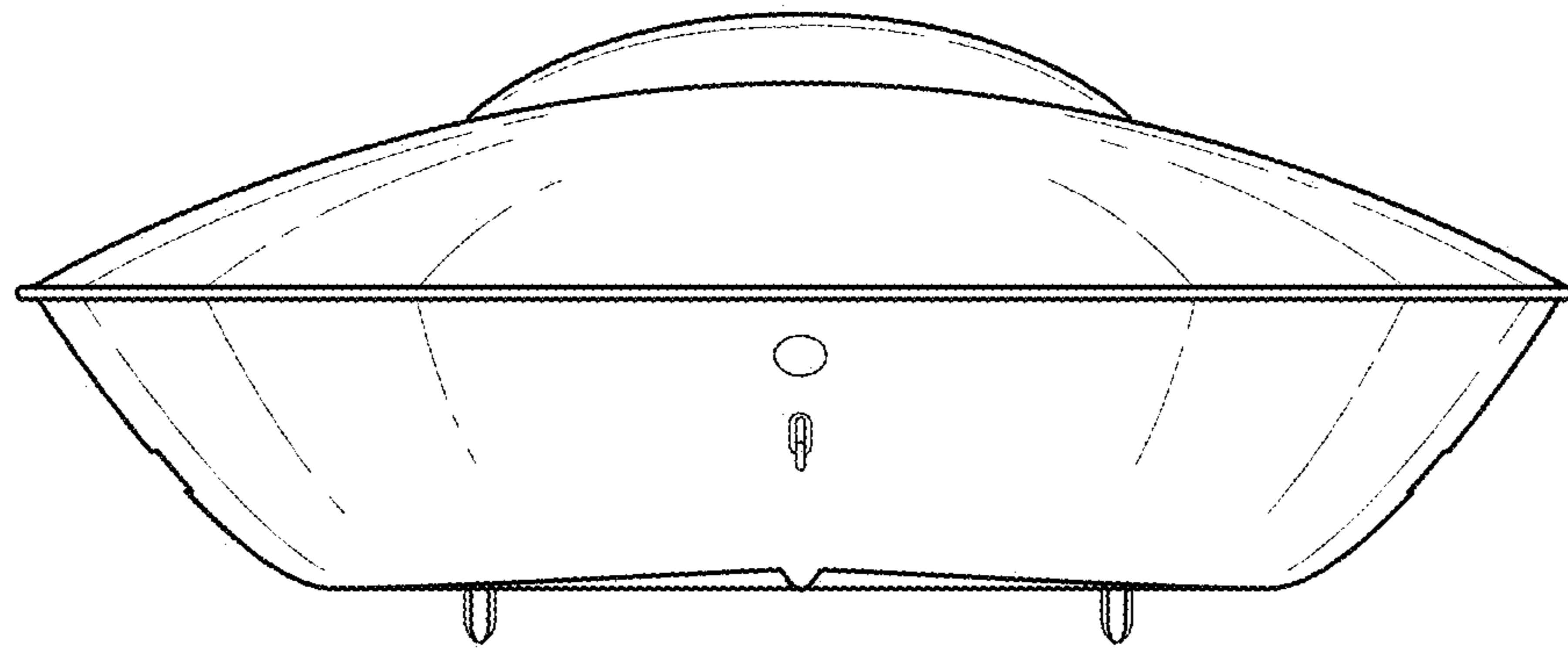

Fig. 5

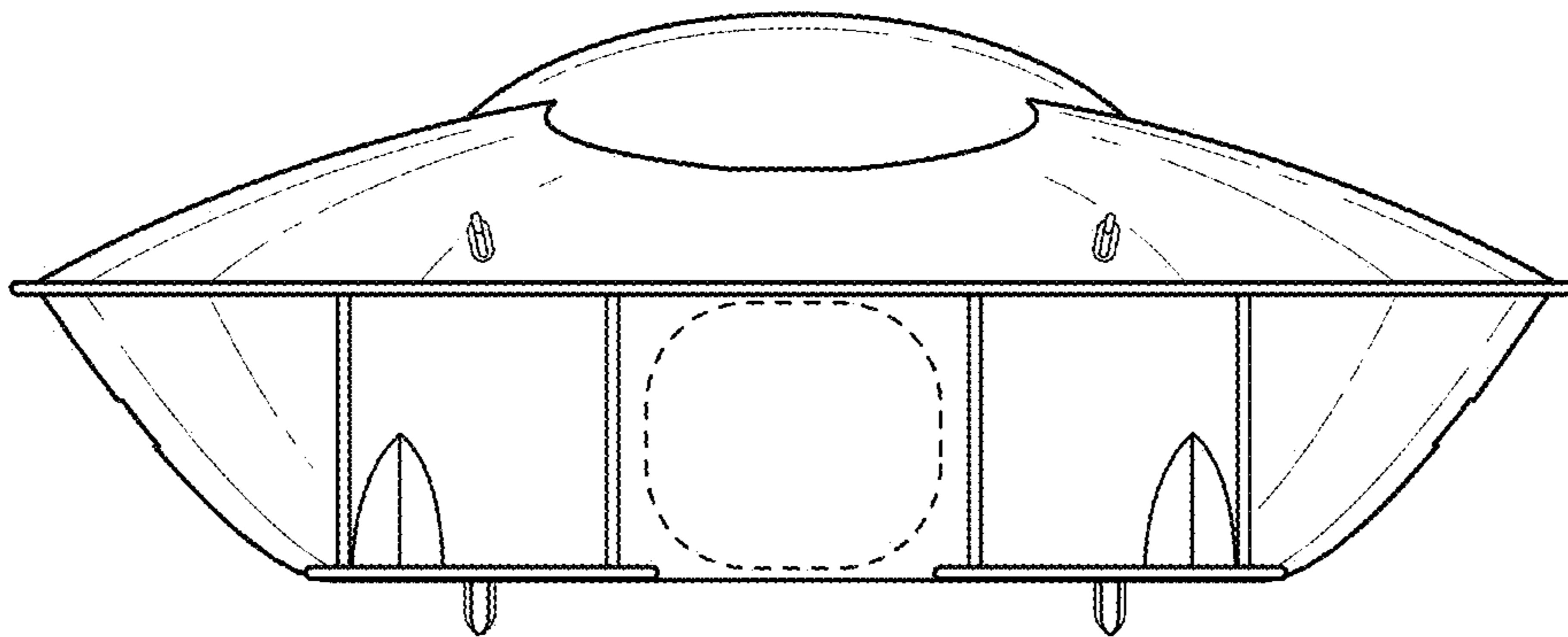

Fig. 6