



US00D700543S

(12) **United States Design Patent**
Dockeray

(10) **Patent No.:** **US D700,543 S**
(45) **Date of Patent:** **** Mar. 4, 2014**

- (54) **VEHICLE**
- (71) Applicant: **Land Rover**, Warwickshire (GB)
- (72) Inventor: **Rebecca Dockeray**, Coventry (GB)
- (73) Assignee: **Land Rover** (GB)
- (**) Term: **14 Years**
- (21) Appl. No.: **29/440,552**
- (22) Filed: **Dec. 21, 2012**

Related U.S. Application Data

- (63) Continuation-in-part of application No. 29/430,533, filed on Aug. 27, 2012.

Foreign Application Priority Data

- (30) Feb. 27, 2012 (EM) 001998824
- (51) **LOC (10) Cl.** **12-08**
- (52) **U.S. Cl.**
USPC **D12/91**
- (58) **Field of Classification Search**
USPC D12/86, 88, 90, 91, 92; D21/424, 433,
D21/434; 296/181.1, 181.5
See application file for complete search history.

References Cited

U.S. PATENT DOCUMENTS

- D157,351 S * 2/1950 De Smet D12/91
- D371,526 S * 7/1996 Verduyn et al. D12/86

(Continued)

OTHER PUBLICATIONS

Land Rover Range Rover Evoque convertible concept is a good thing gone bad . AutoBlog. Mar. 6, 2012 [online], [retrieved on Apr. 18, 2013]. Retrieved from the Internet <URL: <http://www.autoblog.com/2012/03/06/land-rover-range-rover-evoque-convertible-concept-is-a-good-thin/>>.*

(Continued)

Primary Examiner — Philip S Hyder
Assistant Examiner — Darlington Ly
(74) *Attorney, Agent, or Firm* — Rader, Fishman & Grauer PLLC

(57) **CLAIM**
The ornamental design for a vehicle, as shown and described.
DESCRIPTION

FIG. 1 is a front, left side, perspective view of the vehicle; FIG. 2 is a front, left side, perspective view thereof, wherein the convertible top and side windows are shown in a stowed position; FIG. 3 is a rear, left side, perspective view thereof, wherein the convertible top and side windows are shown in a raised position; FIG. 4 is a rear, left side, perspective view thereof, wherein the convertible top and side windows are shown in a stowed position; FIG. 5 is a rear, top, right side, perspective view thereof, wherein the convertible top and side windows are shown in a stowed position; FIG. 6 is a left side elevation view thereof, wherein the convertible top and side windows are shown in a raised position; FIG. 7 is a right side elevation view thereof, wherein the convertible top and side windows are shown in a raised position; FIG. 8 is a left side elevation view thereof, wherein the convertible top and side windows are shown in a stowed position; FIG. 9 is a right side elevation view thereof, wherein the convertible top and side windows are shown in a stowed position; FIG. 10 is a front elevation view thereof, wherein the convertible top and side windows are shown in a raised position; FIG. 11 is a rear elevation view thereof, wherein the convertible top and side windows are shown in a raised position; FIG. 12 is a front elevation view thereof, wherein the convertible top and side windows are shown in a stowed position; FIG. 13 is a rear elevation view thereof, wherein the convertible top and side windows are shown in a stowed position; FIG. 14 is a top plan view thereof, wherein the convertible top and side windows are shown in a raised position; and, FIG. 15 is a top plan view thereof, wherein the convertible top and side windows are shown in a stowed position. The even broken lines shown in the drawings illustrate portions of the vehicle that forms no part of claimed design.

1 Claim, 13 Drawing Sheets

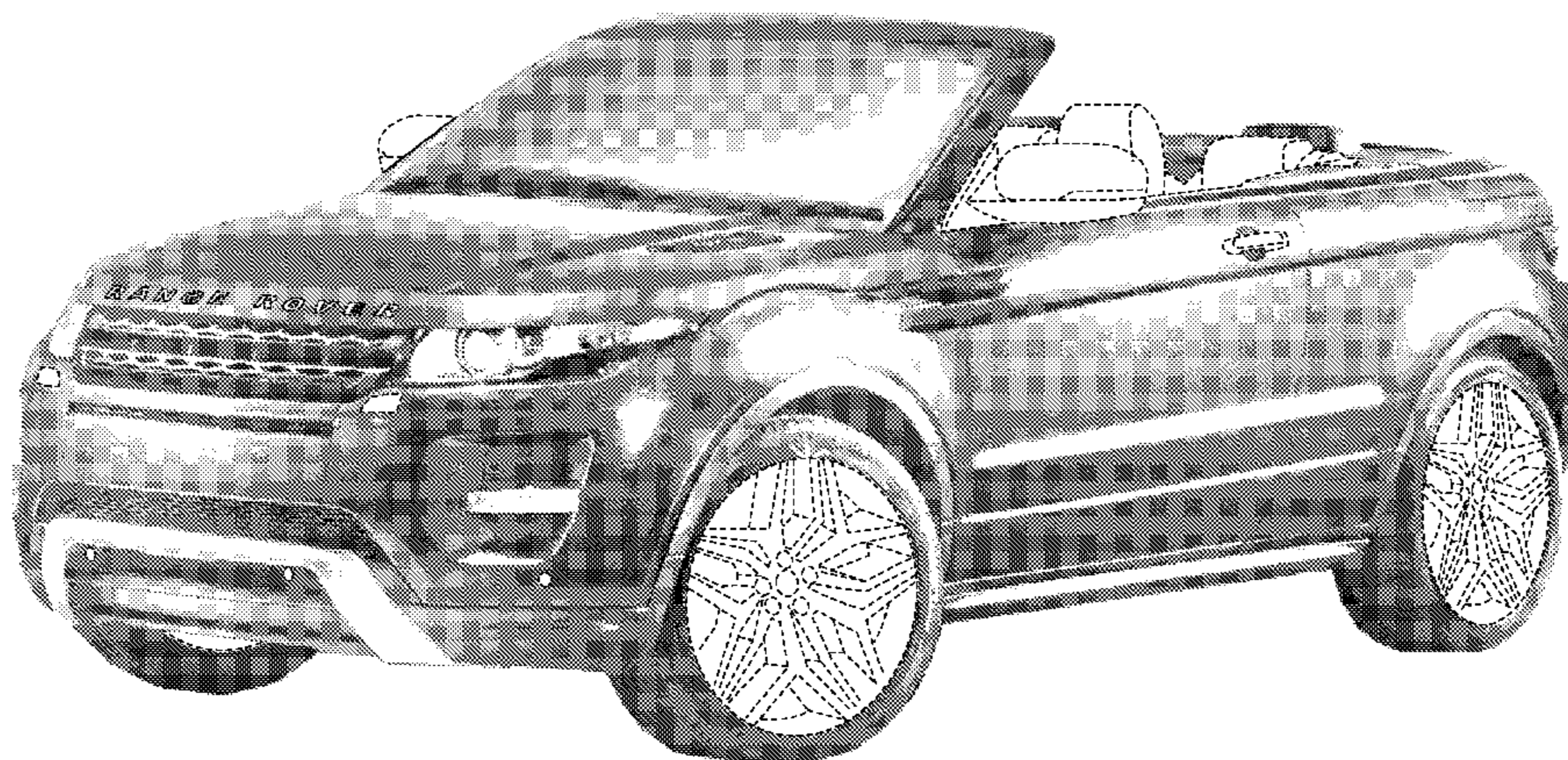

(56)

References Cited

U.S. PATENT DOCUMENTS

D419,919 S * 2/2000 McGovern D12/91
D531,087 S * 10/2006 Newton D12/91
D551,595 S * 9/2007 Newton D12/91
D589,845 S * 4/2009 Shamenkov et al. D12/92
D605,084 S * 12/2009 Szavits D12/91
D610,039 S * 2/2010 Koide et al. D12/90
D626,455 S * 11/2010 Syring D12/92
D626,601 S * 11/2010 Syring 1/1
D631,397 S * 1/2011 Clottu D12/91

D664,894 S * 8/2012 Huet D12/91
D676,787 S * 2/2013 Frenkler et al. D12/91

OTHER PUBLICATIONS

Range Rover Evoque Convertible Concept to be Revealed at the 2012 Geneva Motor Show. Feb. 24, 2012 [online], [retrieved on Apr. 18, 2013]. Retrieved from the Internet <URL: <http://www.interactivelandrover.com/rreconvertible/DisplayRelease.php?itemID=421>>.*

* cited by examiner

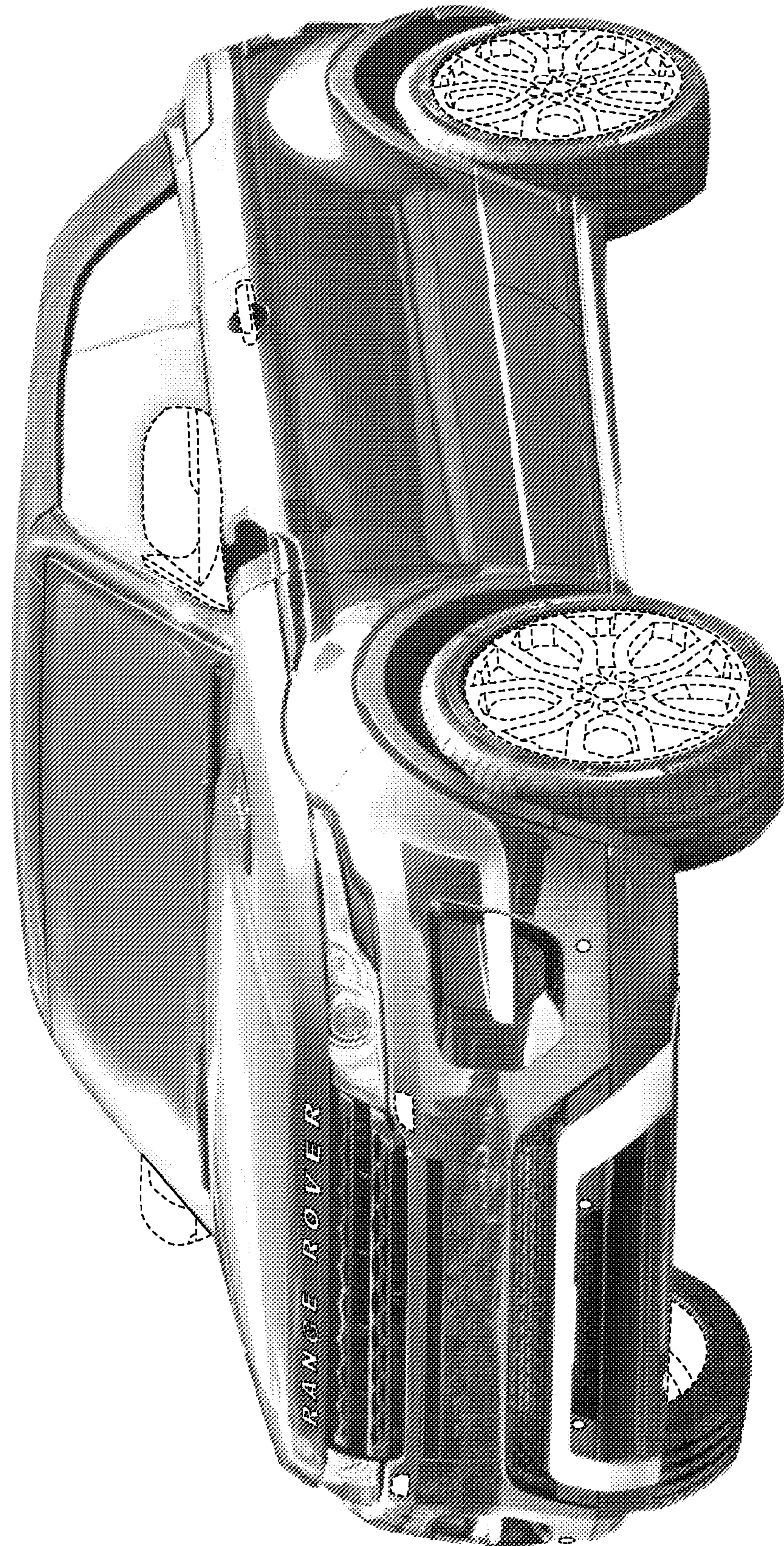

FIG. 1

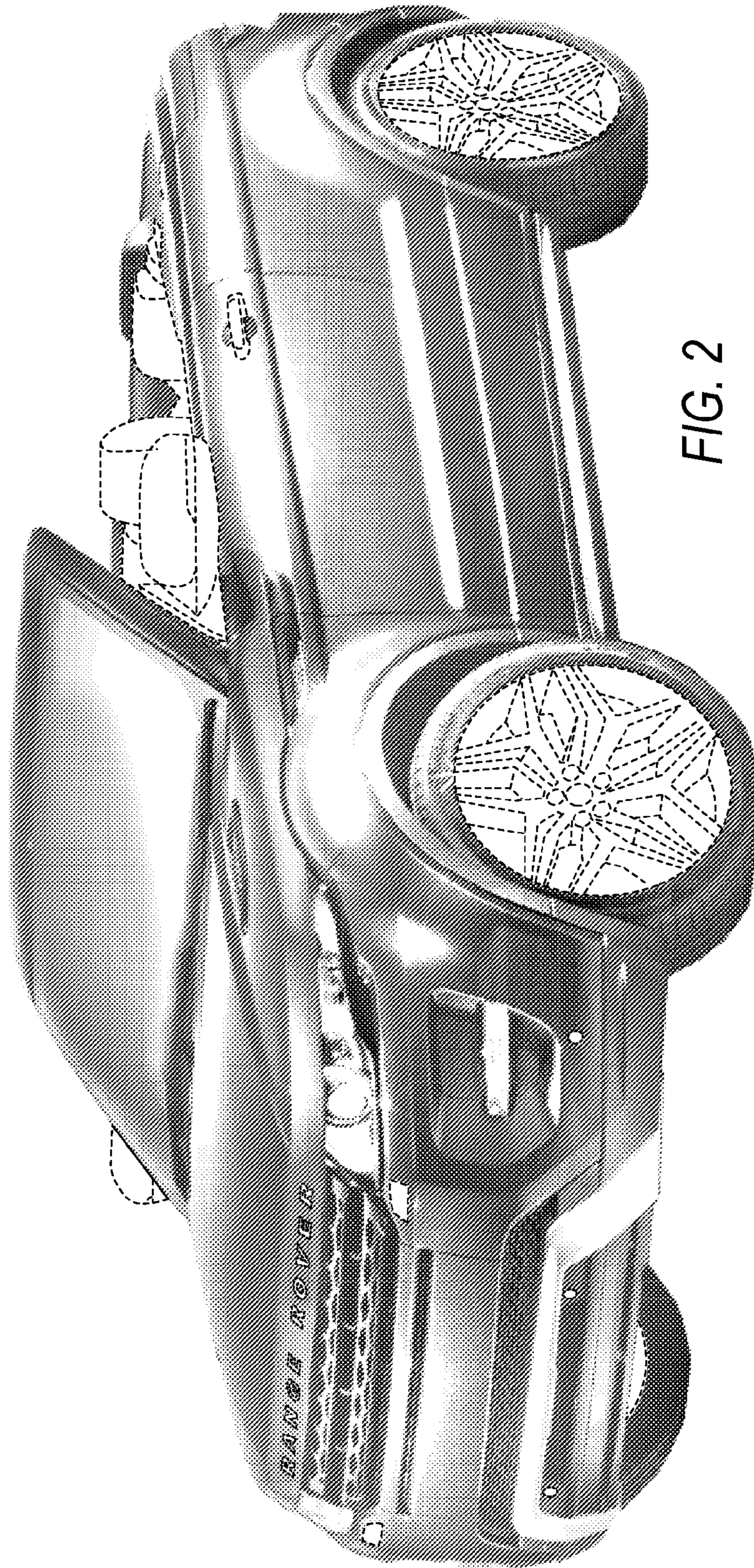

FIG. 2

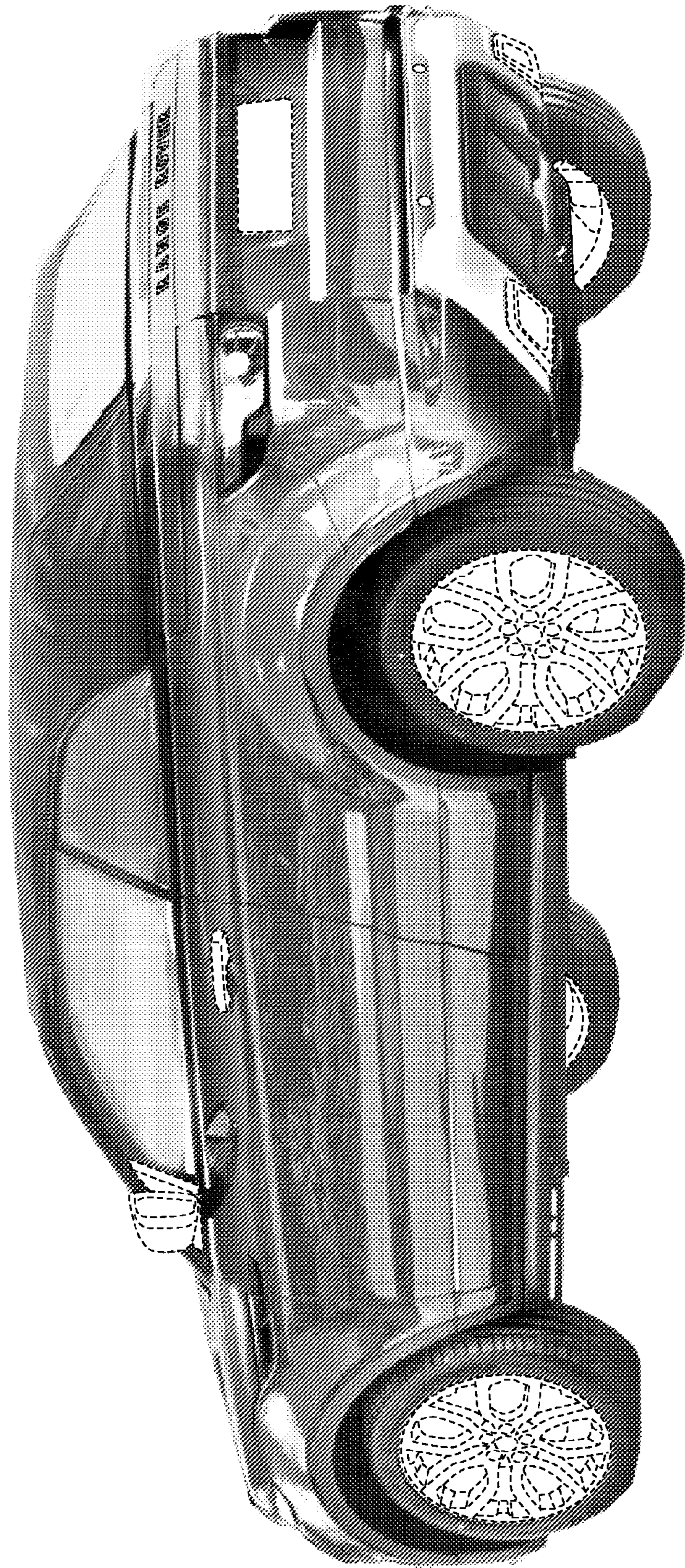

FIG. 3

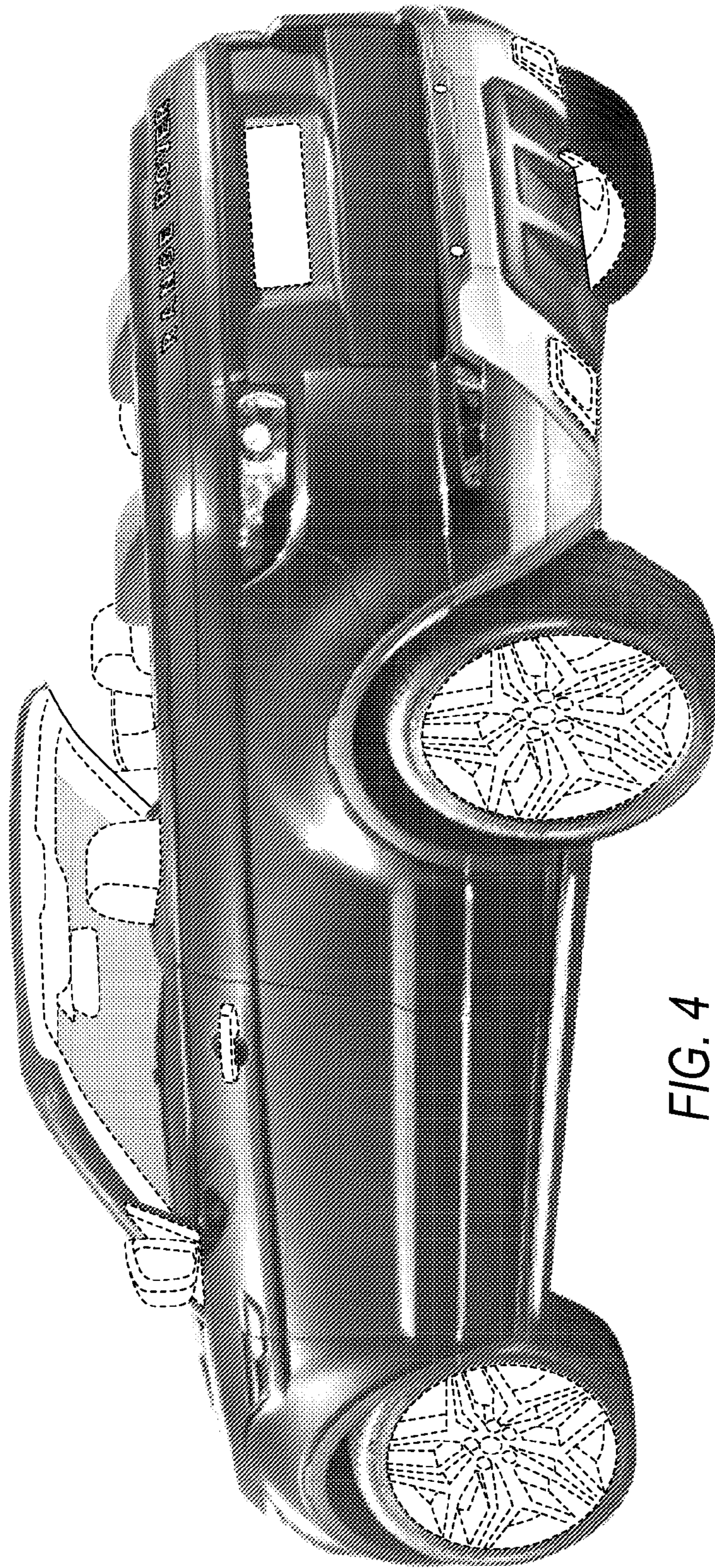

FIG. 4

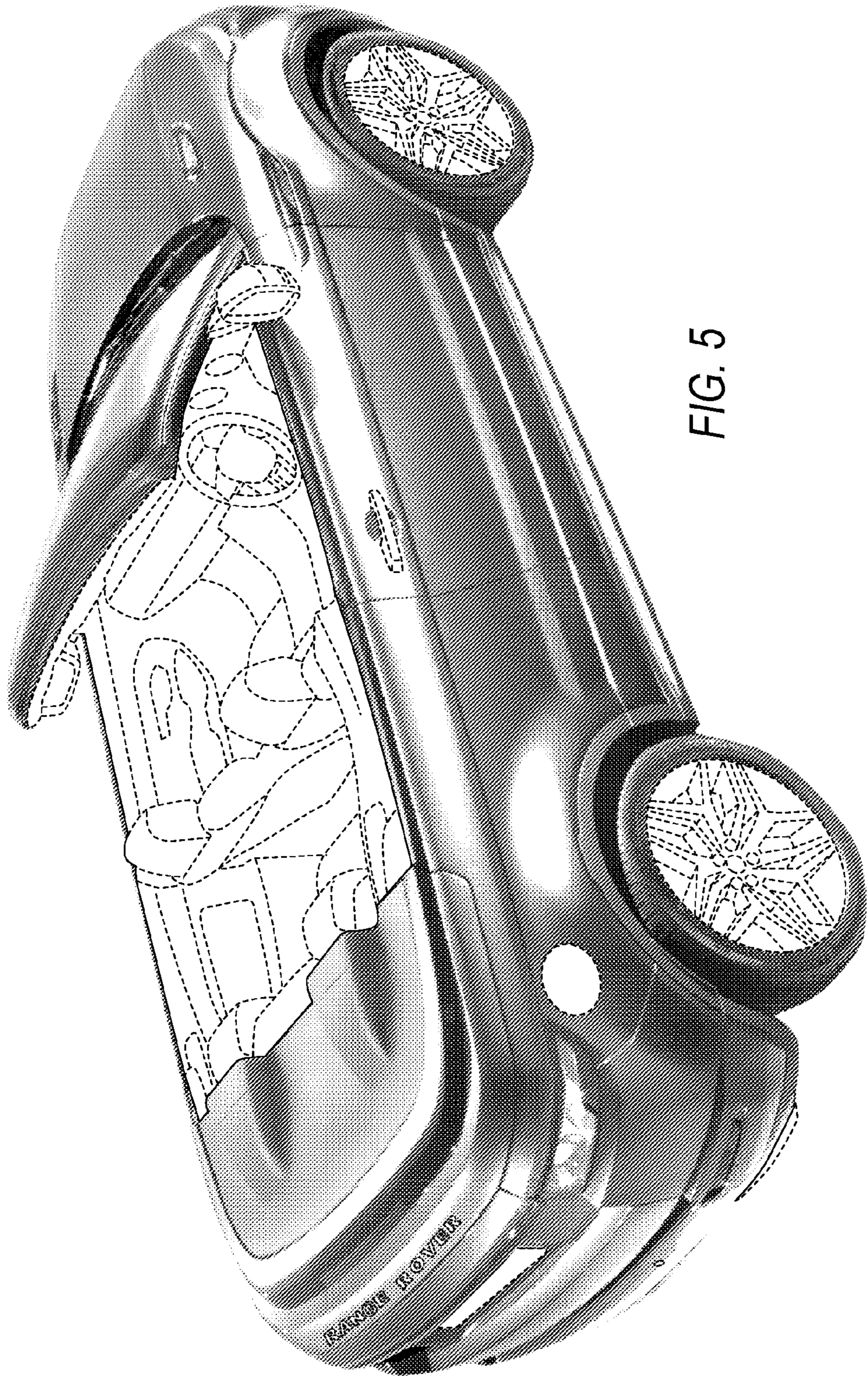

FIG. 5

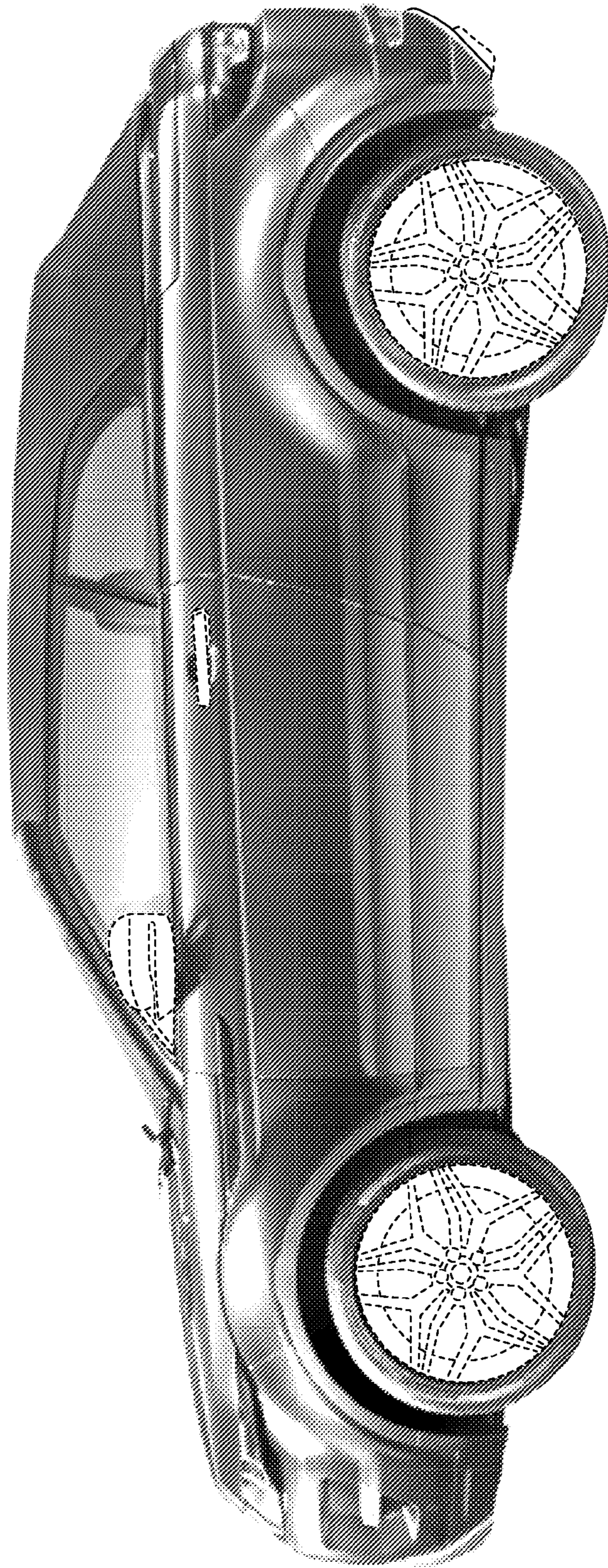

FIG. 6



FIG. 7

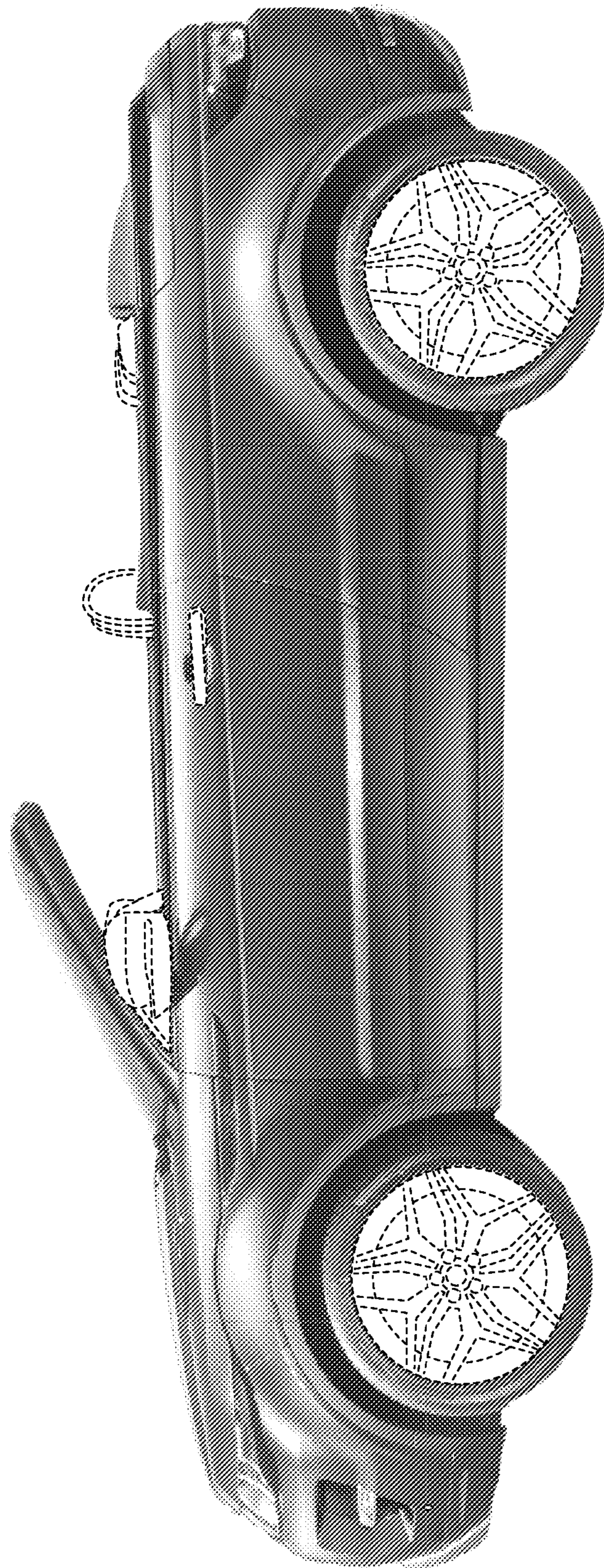

FIG. 8

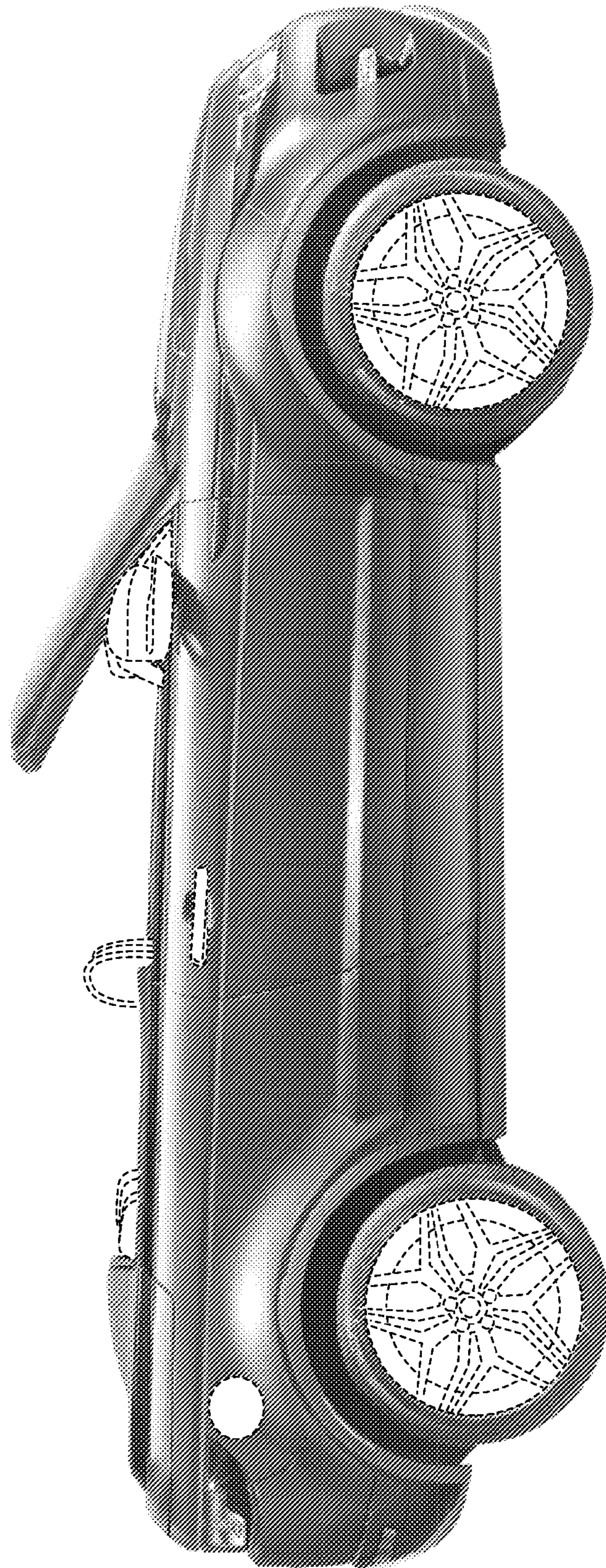

FIG. 9



FIG. 10

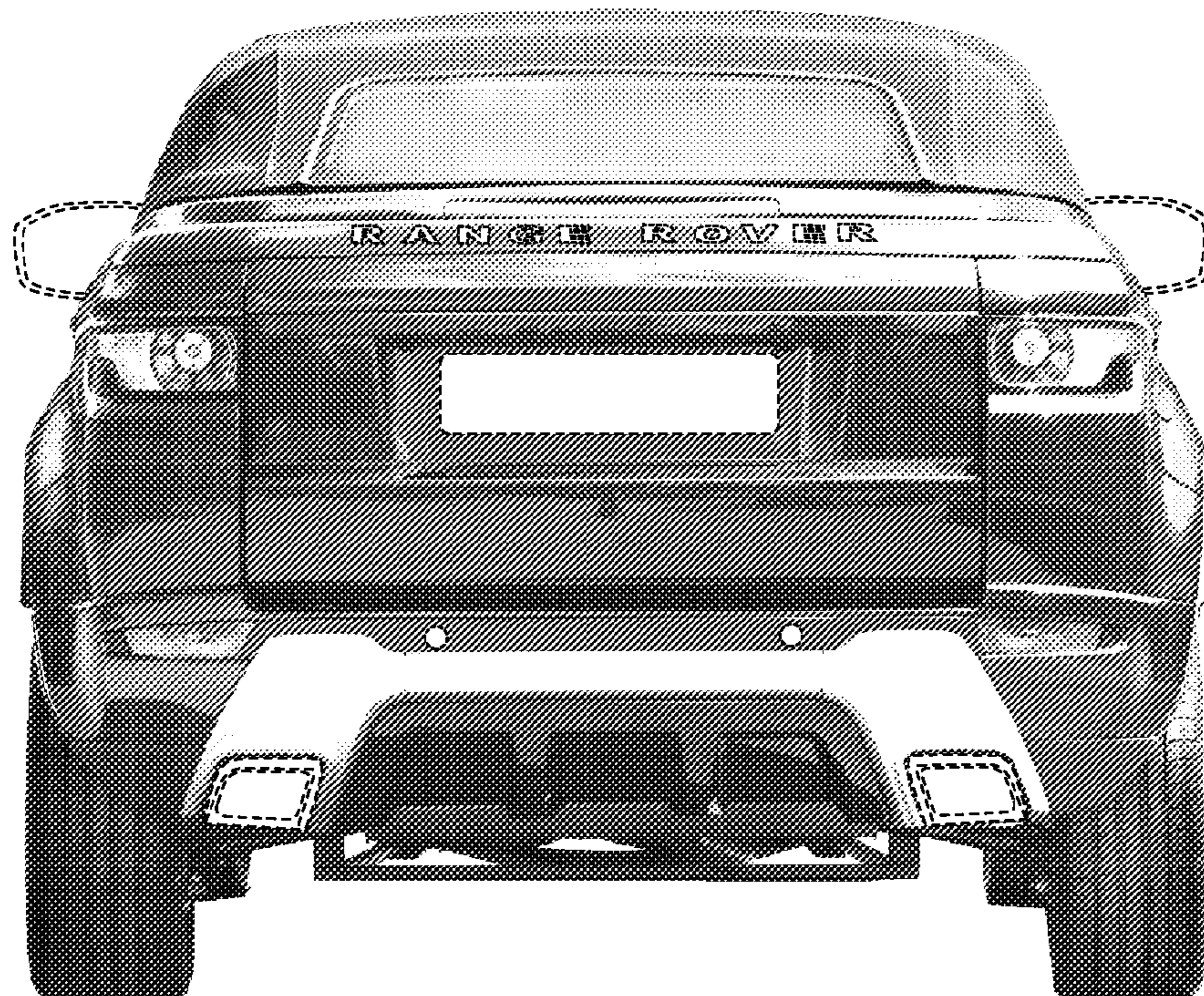

FIG. 11



FIG. 12

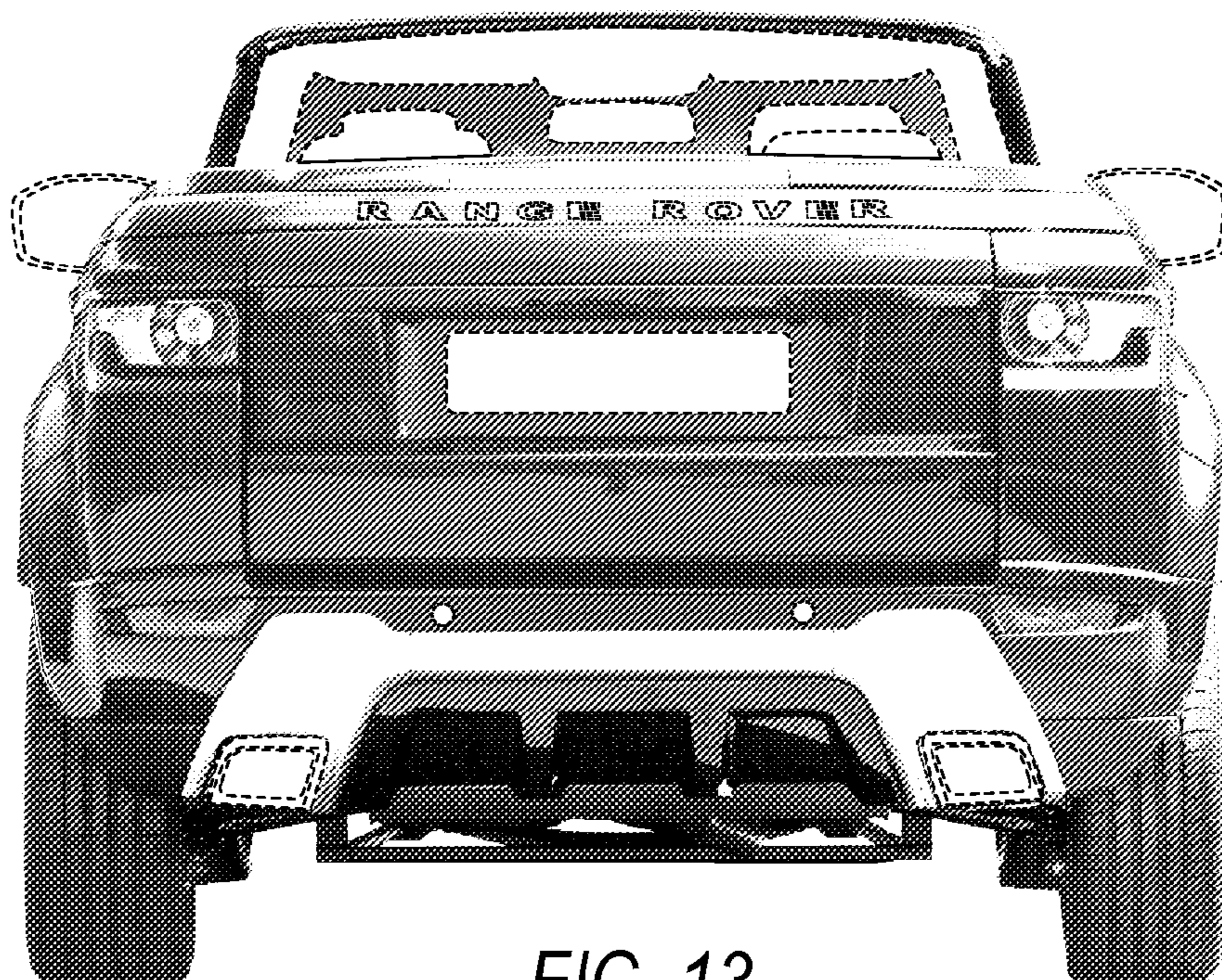

FIG. 13

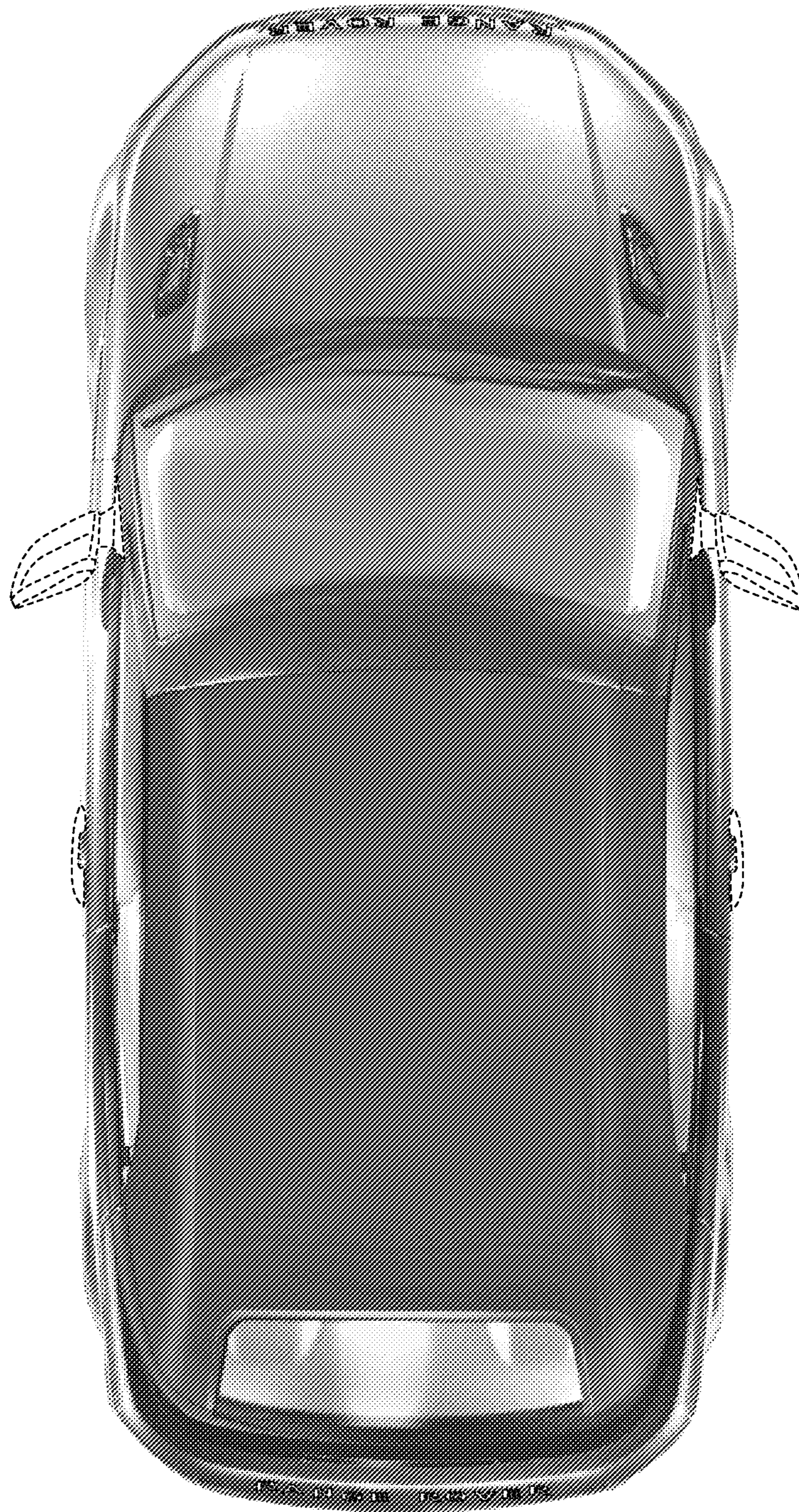

FIG. 14

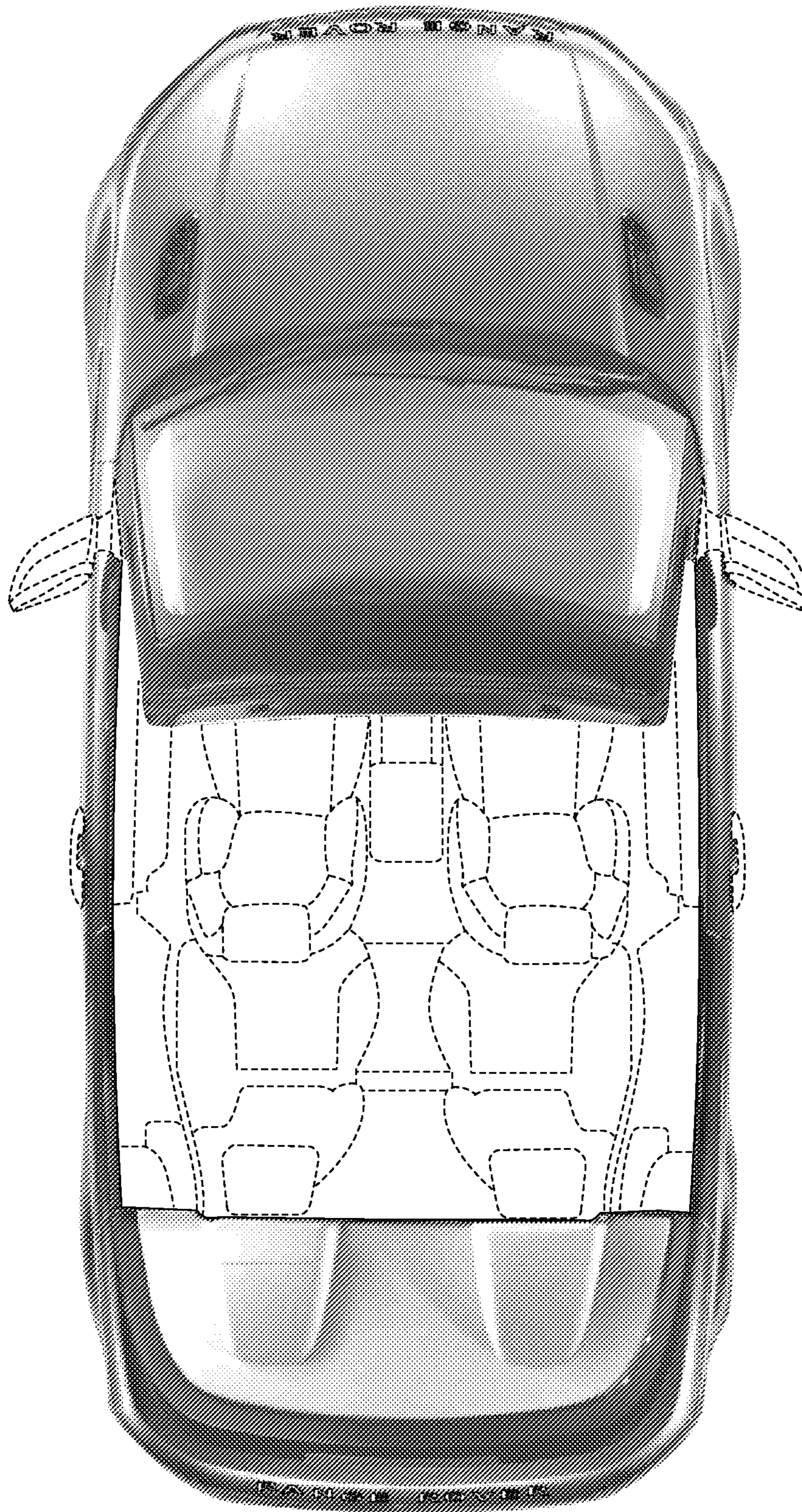

FIG. 15