



US00D699840S

(12) **United States Design Patent**
Lombardi, III et al.

(10) **Patent No.:** **US D699,840 S**

(45) **Date of Patent:** **** Feb. 18, 2014**

(54) **MALE BODY OF CONNECTOR FOR FLUID TUBING**

(75) Inventors: **Francis J. Lombardi, III**, Loveland, CO (US); **Ravikumar Narayanan**, Fort Collins, CO (US); **Richard W. Cairns**, Longmont, CO (US)

(73) Assignee: **Nordson Corporation**, Westlake, OH (US)

(**) Term: **14 Years**

(21) Appl. No.: **29/398,437**

(22) Filed: **Jul. 29, 2011**

(51) **LOC (10) Cl.** **24-02**

(52) **U.S. Cl.**
USPC **D24/129**

(58) **Field of Classification Search**
USPC D24/108–110.5, 127–130; 604/905, 604/533, 544, 408, 538, 43; 285/304–321
See application file for complete search history.

(56) **References Cited**

U.S. PATENT DOCUMENTS

163,261 A	5/1875	Ruppenthal
185,896 A	1/1877	Curtis
187,982 A	3/1877	Pirsson et al.
200,944 A	3/1878	Smith
235,580 A	12/1880	Smith et al.

(Continued)

FOREIGN PATENT DOCUMENTS

BE	479098	1/1948
DE	1868896	3/1963

(Continued)

OTHER PUBLICATIONS

U.S. Appl. No. 29/385,357, filed Feb. 11, 2011, Lombardi et al., Pending.

(Continued)

Primary Examiner — David Muller

(74) *Attorney, Agent, or Firm* — Dorsey & Whitney LLP

(57) **CLAIM**

We claim the ornamental design for a male body of a connector for fluid tubing, as shown and described.

DESCRIPTION

This application is related to U.S. design patent application Ser. No. 29/398,433 filed 29 Jul. 2011 entitled “Connector for fluid tubing” and U.S. design patent application Ser. No. 29/398,440 filed 29 Jul. 2011 entitled “Female body of connector for fluid tubing.”

FIG. 1 is a top-left-front isometric view of a male body of a connector for fluid tubing.

FIG. 2 is a top-right-rear isometric view of the male body of a connector for fluid tubing of FIG. 1

FIG. 3 is a left side elevation view of the male body of FIG. 1.

FIG. 4 is a right side elevation view of the male body of FIG. 1.

FIG. 5 is a front elevation view of the male body of FIG. 1.

FIG. 6 is a rear elevation view of the male body of FIG. 1.

FIG. 7 is a top plan view of the male body of FIG. 1.

FIG. 8 is a bottom plan view of the male body of FIG. 1.

FIG. 9 is a cross-section view of the male body of FIG. 1 viewed along line 9-9 in FIG. 7; and,

FIG. 10 is a cross-section view of the male body of FIG. 1 similar to FIG. 9, but with a portion in break-away in order to reveal features obscured in FIG. 9.

1 Claim, 6 Drawing Sheets

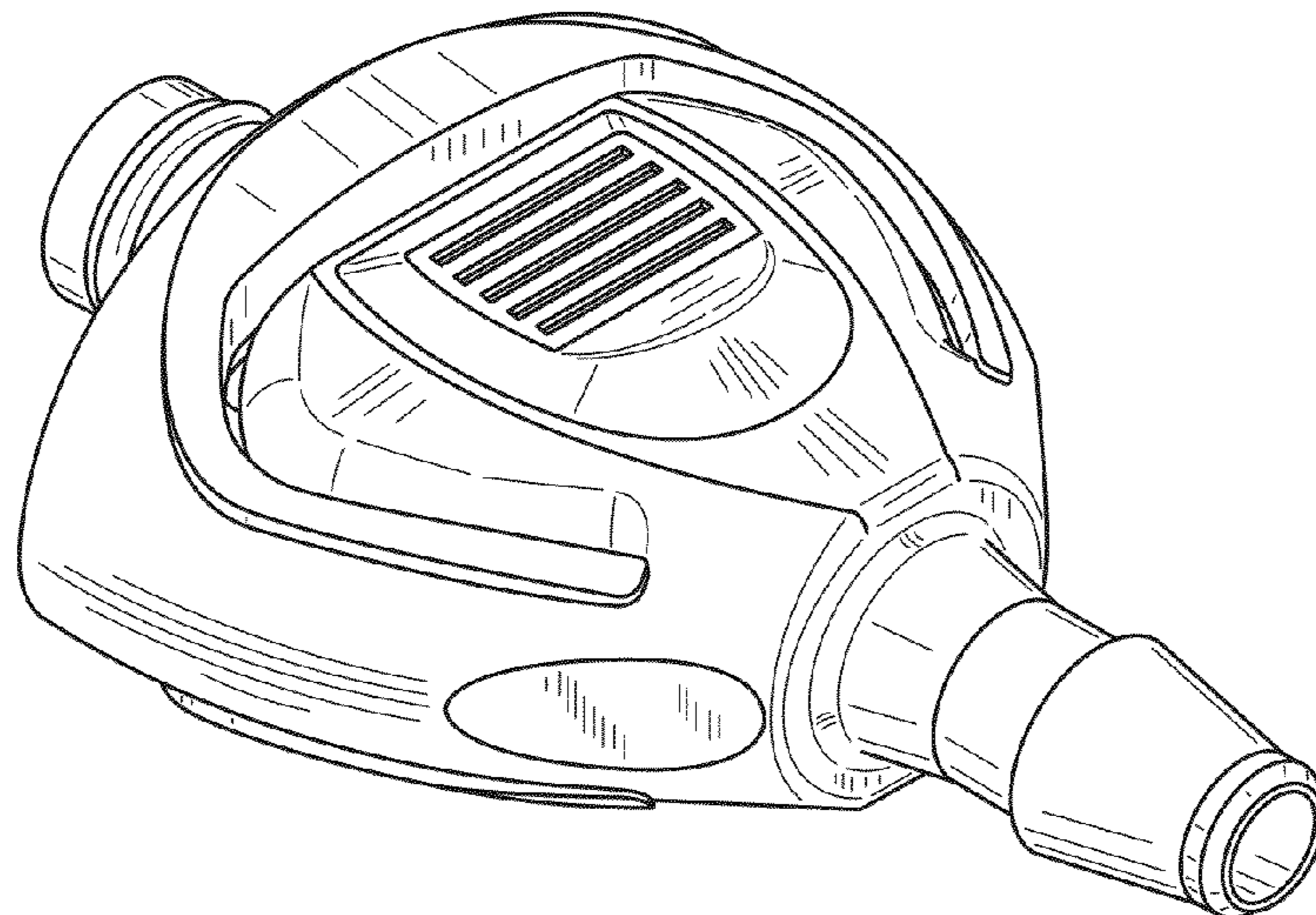

(56)

References Cited

U.S. PATENT DOCUMENTS

327,509 A	10/1885	Aldridge	D196,473 S	10/1963	Hill
584,008 A	6/1887	Munson	3,124,157 A	3/1964	Krzewina
465,868 A	12/1891	List	3,129,020 A	4/1964	Bujnowski
725,421 A	4/1903	Dinkins	3,171,196 A	3/1965	Helitas
727,982 A	5/1903	Ludwig	3,191,628 A	6/1965	Kirkwood et al.
874,957 A	12/1907	Godley	3,217,400 A	11/1965	Illesy et al.
884,461 A	4/1908	Browne	3,217,771 A	11/1965	Beall et al.
909,131 A	1/1909	Antic	3,227,380 A	1/1966	Pinkston
951,889 A	3/1910	Teuer	3,237,974 A	3/1966	Press
D42,368 S	3/1912	Mossberg	3,245,703 A	4/1966	Manly
1,029,819 A	6/1912	Nylander	3,276,799 A	10/1966	Moore et al.
1,033,187 A	7/1912	Metzger	3,279,497 A	10/1966	Norton et al.
1,039,354 A	9/1912	Bonadio	3,314,696 A	4/1967	Ferguson et al.
1,077,417 A	11/1913	McCracken	3,317,214 A	5/1967	Durgom
1,078,112 A	11/1913	Storm	D209,166 S	11/1967	Hunt
1,115,945 A	11/1914	Kunz	D209,168 S	11/1967	Hunt
1,193,446 A	8/1916	Wells	3,352,576 A	11/1967	Thomas
1,239,345 A	9/1917	Brown	3,382,892 A	5/1968	Cerbin
1,255,847 A	2/1918	Arkin	3,403,930 A	10/1968	Bernier
1,259,684 A	3/1918	Vinten	3,432,176 A	3/1969	Valenziano
1,489,310 A	4/1924	Critchlow	3,448,760 A	6/1969	Cranage
1,526,218 A	2/1925	Johnson	3,450,424 A	6/1969	Calisher
1,578,504 A	3/1926	Bronson et al.	3,512,808 A	5/1970	Graham
1,587,079 A	6/1926	Machino	3,523,701 A	8/1970	Graham
1,767,073 A	6/1930	Ingold	3,538,940 A	11/1970	Graham
1,863,360 A	6/1932	Weatherhead	3,542,338 A	11/1970	Scaramucci
1,950,947 A	3/1934	Mulroyan	3,545,490 A	12/1970	Burrus
2,023,428 A	12/1935	Liebhardt	3,550,626 A	12/1970	Daniels et al.
2,056,524 A	10/1936	Johnson	3,560,027 A	2/1971	Graham
2,066,473 A	1/1937	Jorgensen	3,563,265 A	2/1971	Graham
2,097,628 A	11/1937	Liebhardt	3,574,314 A	4/1971	Quercia
2,099,335 A	11/1937	Hansen	3,588,149 A	6/1971	Demler
2,108,714 A	2/1938	Hirsch et al.	3,596,933 A	8/1971	Luckenbill
2,116,705 A	5/1938	Marx et al.	3,599,843 A	8/1971	Johnston
2,139,745 A	12/1938	Goodall	3,600,917 A	8/1971	Krock
2,147,355 A	2/1939	Scholtes	3,649,050 A	3/1972	Woodling
2,159,116 A	5/1939	Zacharias	3,666,297 A	5/1972	Marks
2,211,147 A	8/1940	Miller	3,690,336 A	9/1972	Drum
2,257,321 A	9/1941	Arnold	3,712,583 A	1/1973	Martindale et al.
2,263,293 A	11/1941	Ewald	3,747,964 A	7/1973	Nilsen
2,264,815 A	12/1941	Thomsen	3,750,238 A	8/1973	Tanner
2,340,119 A	1/1944	Graham	3,815,887 A	6/1974	Curtis et al.
2,346,445 A	4/1944	Merker et al.	3,817,561 A	6/1974	Kay
2,352,728 A	7/1944	Merker et al.	3,829,135 A	8/1974	Forni
2,429,782 A	10/1947	Versoy	3,876,234 A	4/1975	Harms
2,432,946 A	12/1947	Theunissen	3,889,710 A	6/1975	Brost
2,470,800 A	5/1949	Ashton	3,899,200 A	8/1975	Gamble
2,479,499 A	8/1949	Le Clair	3,921,656 A	11/1975	Meisenheimer, Jr. et al.
2,500,720 A	3/1950	Van der Heem	3,979,934 A	9/1976	Isenmann
2,507,536 A	5/1950	Goodson	3,990,674 A	11/1976	Schattenberg
2,516,583 A	7/1950	Moore	3,995,659 A	12/1976	Cantore
2,535,740 A	12/1950	Knopp	4,025,049 A	5/1977	Schmidt
2,577,009 A	12/1951	Frantz	4,039,213 A	8/1977	Walters
2,626,974 A	1/1953	Howard et al.	4,072,330 A	2/1978	Brysch
2,630,131 A	3/1953	Snyder	4,099,748 A	7/1978	Kavick
2,661,018 A	12/1953	Snyder	4,113,627 A	9/1978	Leason
2,701,147 A	2/1955	Summerville	4,116,476 A	9/1978	Porter et al.
2,722,399 A	11/1955	Oetiker	4,129,145 A	12/1978	Wynn
2,753,195 A	7/1956	Palmer	4,142,546 A	3/1979	Sandau
2,774,616 A	12/1956	Dodd et al.	D252,470 S	7/1979	Pawlak
2,790,571 A	4/1957	Flaith et al.	4,181,149 A	1/1980	Cox
2,864,628 A	12/1958	Edleson	4,182,519 A	1/1980	Wilson
2,915,325 A	12/1959	Foster	D254,505 S	3/1980	Parsons et al.
2,926,934 A	3/1960	Gill	4,200,605 A	4/1980	Imamura
2,931,668 A	4/1960	Baley	D255,145 S	5/1980	Nederman
2,937,892 A	5/1960	Prescott, Jr.	4,220,360 A	9/1980	Jacek et al.
2,948,553 A	8/1960	Gill et al.	D258,526 S	3/1981	Nederman
2,967,067 A	1/1961	Singer	4,253,687 A	3/1981	Maples
2,991,090 A	7/1961	De Cenzo	D259,278 S	5/1981	McCaw
3,017,203 A	1/1962	Macleod	4,271,865 A	6/1981	Galloway et al.
3,037,497 A	6/1962	Roberson	4,282,175 A	8/1981	Volgstadt et al.
3,046,028 A	7/1962	Nathan	4,287,644 A	9/1981	Durand
3,048,415 A	8/1962	Shook	4,294,285 A	10/1981	Joslyn
3,073,342 A	1/1963	Magorien	4,296,949 A	10/1981	Muetterties et al.
3,078,068 A	2/1963	Romney	4,319,774 A	3/1982	Kavick
			4,330,010 A	5/1982	Drescher et al.
			4,330,142 A	5/1982	Paini
			4,331,175 A	5/1982	Brake et al.
			4,331,177 A	5/1982	Makishima

(56)

References Cited

U.S. PATENT DOCUMENTS

4,340,200	A	7/1982	Stegmeier	D314,233	S	1/1991	Medvick
4,345,786	A	8/1982	Egert	4,982,736	A	1/1991	Schneider
4,346,703	A	8/1982	Dennehey	4,991,880	A	2/1991	Bernart
4,351,351	A	9/1982	Flory et al.	5,009,252	A	4/1991	Faughn
4,366,816	A	1/1983	Bayard et al.	5,015,014	A	5/1991	Sweeney
4,393,548	A	7/1983	Herb	5,029,908	A	7/1991	Belisaire
4,397,442	A	8/1983	Larkin	5,033,777	A	7/1991	Blenkush
4,407,526	A	10/1983	Cicenas	D319,312	S	8/1991	Schneider
4,431,031	A	2/1984	Ettlenger	5,052,725	A	10/1991	Meyer et al.
4,431,218	A	2/1984	Paul	5,074,601	A	12/1991	Spors et al.
4,434,121	A	2/1984	Schaper	5,076,615	A	12/1991	Sampson
4,436,125	A	3/1984	Blenkush	5,078,429	A	1/1992	Braut et al.
4,437,689	A	3/1984	Goebel et al.	5,085,472	A	2/1992	Guest
4,439,188	A	3/1984	Dennehey	5,090,448	A	2/1992	Truchet
4,458,719	A	7/1984	Strybel	5,090,747	A	2/1992	Kotake
4,489,914	A	12/1984	Stevenson et al.	5,094,482	A	3/1992	Petty et al.
4,489,961	A	12/1984	Laidig	5,104,158	A	4/1992	Meyer et al.
4,500,118	A	2/1985	Blenkush	5,106,127	A	4/1992	Briet
4,527,745	A	7/1985	Butterfield et al.	D326,155	S	5/1992	Boehringer et al.
4,541,457	A	9/1985	Blenkush	5,110,163	A	5/1992	Benson et al.
4,541,657	A	9/1985	Smyth	5,112,084	A	5/1992	Washizu
4,553,587	A	11/1985	Traylor	5,114,250	A	5/1992	Usui
D282,962	S	3/1986	Gerber	D326,715	S	6/1992	Schmidt
4,580,816	A	4/1986	Campbell et al.	5,123,677	A	6/1992	Kreczko et al.
4,603,888	A	8/1986	Goodall et al.	5,143,381	A	9/1992	Temple
4,603,890	A	8/1986	Huppee	5,160,177	A	11/1992	Washizu
4,613,112	A	9/1986	Philipot et al.	5,160,474	A	11/1992	Huff
4,616,859	A	10/1986	Brunet	5,165,733	A	11/1992	Sampson
4,626,001	A	12/1986	Lee	5,169,161	A	12/1992	Jones
4,630,847	A	12/1986	Blenkush	D332,482	S	1/1993	Petty et al.
4,632,436	A	12/1986	Kimura	5,176,406	A	1/1993	Straghan
4,635,972	A	1/1987	Lyll	5,178,303	A	1/1993	Blenkush et al.
4,645,245	A	2/1987	Cunningham	5,181,752	A	1/1993	Benson et al.
4,658,326	A	4/1987	Clark et al.	D333,178	S	2/1993	Novy
4,659,116	A	4/1987	Cameron	5,190,224	A	3/1993	Hamilton
4,694,544	A	9/1987	Chapman	5,222,279	A	6/1993	Franco et al.
4,699,298	A	10/1987	Grant et al.	5,228,724	A	7/1993	Godeau
4,700,926	A	10/1987	Hansen	5,232,020	A	8/1993	Mason et al.
4,703,957	A	11/1987	Blenkush	D339,417	S	9/1993	Sampson et al.
4,706,847	A	11/1987	Sankey et al.	5,251,025	A	10/1993	Cooper et al.
4,712,280	A	12/1987	Fildan	5,273,053	A	12/1993	Pohndorf
4,733,890	A	3/1988	Vyse	5,297,826	A	3/1994	Percebois et al.
4,738,401	A	4/1988	Filicicchia	5,316,041	A	5/1994	Ramacier, Jr. et al.
4,753,268	A	6/1988	Palau	5,318,332	A	6/1994	Hohmann et al.
4,768,558	A	9/1988	Weber	5,330,235	A	7/1994	Wagner et al.
4,776,067	A	10/1988	Sorensen	5,348,051	A	9/1994	Kallenbach
4,790,567	A	12/1988	Kawano et al.	5,348,354	A	9/1994	Badoureaux
4,790,569	A	12/1988	Chaffee	5,353,836	A	10/1994	deCler et al.
4,792,115	A	12/1988	Jindra et al.	5,356,183	A	10/1994	Cole
4,793,637	A	12/1988	Laipply et al.	5,374,088	A	12/1994	Moretti et al.
4,806,123	A	2/1989	Konishi et al.	5,385,311	A	1/1995	Morikawa et al.
D300,361	S	3/1989	Tokarz	5,385,331	A	1/1995	Allread et al.
4,824,148	A	4/1989	Grabowski	D357,307	S	4/1995	Ramacier, Jr. et al.
4,827,921	A	5/1989	Rugheimer	5,405,333	A	4/1995	Richmond
4,832,237	A	5/1989	Hurford, Jr.	5,405,339	A	4/1995	Kohnen et al.
4,834,423	A	5/1989	DeLand	5,405,340	A	4/1995	Fageol et al.
4,844,512	A	7/1989	Gahwiler	5,411,300	A	5/1995	Mitsui
4,863,201	A	9/1989	Carstens	5,417,442	A	5/1995	Jornhagen
4,863,202	A	9/1989	Oldford	5,421,622	A	6/1995	Godeau
4,896,402	A	1/1990	Jansen et al.	5,437,650	A	8/1995	Larkin et al.
4,900,065	A	2/1990	Houck	5,462,313	A	10/1995	Rea et al.
4,903,995	A	2/1990	Blenkush et al.	5,494,074	A	2/1996	Ramacier, Jr. et al.
4,923,228	A	5/1990	Laipply et al.	D369,409	S	4/1996	Salter
4,928,859	A	5/1990	Krahn et al.	5,507,733	A	4/1996	Larkin et al.
4,928,999	A	5/1990	Landriault et al.	5,511,527	A	4/1996	Lorraine et al.
4,934,655	A	6/1990	Blenkush et al.	D372,093	S	7/1996	Sampson et al.
4,935,992	A	6/1990	Due	5,536,258	A	7/1996	Folden
4,946,200	A	8/1990	Blenkush et al.	5,542,712	A	8/1996	Klinger et al.
4,946,204	A	8/1990	Boticki	5,547,166	A	8/1996	Engdahl
4,949,745	A	8/1990	McKeon	5,547,230	A	8/1996	Bank et al.
4,966,398	A	10/1990	Peterson	5,553,895	A	9/1996	Karl et al.
4,969,879	A	11/1990	Lichte	D375,160	S	10/1996	Sampson et al.
D313,067	S	12/1990	Kotake et al.	5,568,946	A	10/1996	Jackowski
D313,277	S	12/1990	Haining	5,595,217	A	1/1997	Gillen et al.
D314,050	S	1/1991	Sone	5,601,317	A	2/1997	Crouse et al.
				5,607,190	A	3/1997	Exandier et al.
				5,617,609	A	4/1997	Bently
				5,620,025	A	4/1997	Lewin
				5,628,726	A	5/1997	Cotter

(56)

References Cited

U.S. PATENT DOCUMENTS

D380,262	S	6/1997	Van Funderburk et al.	6,199,920	B1	3/2001	Neustadtl
5,639,064	A	6/1997	deCler et al.	6,206,028	B1	3/2001	Holden et al.
D382,639	S	8/1997	Musgrave et al.	6,221,064	B1	4/2001	Nadal
D384,731	S	10/1997	Ramacier, Jr. et al.	6,231,089	B1	5/2001	DeCler et al.
5,681,062	A	10/1997	Fukao et al.	D444,054	S	6/2001	Bernard et al.
5,682,662	A	11/1997	Coules et al.	6,250,688	B1	6/2001	Kirby
5,683,117	A	11/1997	Corbett et al.	6,257,626	B1	7/2001	Campau
D387,147	S	12/1997	Vandermast et al.	6,260,851	B1	7/2001	Baron
5,692,783	A	12/1997	Watanabe et al.	6,261,282	B1	7/2001	Jepson et al.
5,695,223	A	12/1997	Boticki	6,293,596	B1	9/2001	Kinder
D388,876	S	1/1998	Sampson	6,296,796	B1	10/2001	Gordon
5,709,244	A	1/1998	Patriquin et al.	6,302,147	B1	10/2001	Rose et al.
5,725,258	A	3/1998	Kujawski	6,318,764	B1	11/2001	Trede et al.
5,737,810	A	4/1998	Krauss	6,344,033	B1	2/2002	Jepson et al.
5,745,957	A	5/1998	Khokhar et al.	6,382,593	B1	5/2002	deCler et al.
5,746,414	A	5/1998	Weldon et al.	D459,206	S	6/2002	Caveney et al.
5,762,646	A	6/1998	Cotter	6,402,207	B1	6/2002	Segal et al.
5,784,750	A	7/1998	Sankovic et al.	6,422,574	B1	7/2002	Mooklar
5,799,987	A	9/1998	Sampson	6,423,053	B1	7/2002	Lee
5,820,614	A	10/1998	Erskine et al.	6,439,620	B1	8/2002	Guest
5,837,180	A	11/1998	Linder et al.	6,454,314	B1	9/2002	Grosspietsch et al.
5,845,943	A	12/1998	Ramacier, Jr. et al.	6,481,758	B1	11/2002	Andre et al.
5,855,568	A	1/1999	Battiato et al.	6,481,759	B1	11/2002	Kawasaki et al.
5,879,033	A	3/1999	Hansel et al.	6,485,064	B1	11/2002	Davidson
5,882,047	A	3/1999	Ostrander et al.	6,485,483	B1	11/2002	Fujii
5,884,531	A	3/1999	Koenig	6,505,866	B1	1/2003	Nakamura et al.
D407,803	S	4/1999	Redman	6,508,807	B1	1/2003	Peters
5,897,142	A	4/1999	Kulevsky	6,520,546	B2	2/2003	Szabo
5,911,367	A	6/1999	McInerney	D471,261	S	3/2003	Kozu
5,911,403	A	6/1999	deCler et al.	6,540,263	B1	4/2003	Sausner
5,911,404	A	6/1999	Cheng	6,543,745	B1	4/2003	Enerson
5,930,424	A	7/1999	Heimberger et al.	6,595,964	B2	7/2003	Finley et al.
5,937,501	A	8/1999	Imgram	6,609,696	B2	8/2003	Enerson
5,938,244	A	8/1999	Meyer	6,612,634	B1	9/2003	Zoppas
5,941,577	A	8/1999	Musellec	6,626,419	B2	9/2003	DeCler et al.
5,942,730	A	8/1999	Schwarz et al.	6,626,465	B2	9/2003	Lacroix et al.
D413,967	S	9/1999	Yuen	D481,125	S	10/2003	Hayamizu
5,957,898	A	9/1999	Jepson et al.	6,641,177	B1	11/2003	Pinciaro
5,961,157	A	10/1999	Baron et al.	6,649,829	B2	11/2003	Garber et al.
5,964,485	A	10/1999	Hame et al.	6,652,007	B1	11/2003	Hwang
5,965,077	A	10/1999	Rowley et al.	D484,241	S	12/2003	Peters et al.
5,975,489	A	11/1999	deCler et al.	6,669,681	B2	12/2003	Jepson et al.
5,984,378	A	11/1999	Ostrander et al.	6,676,172	B2	1/2004	Alksnis
5,988,704	A	11/1999	Ryhman	D486,909	S	2/2004	Cise et al.
6,012,743	A	1/2000	Godeau et al.	6,688,654	B2	2/2004	Romero
6,015,171	A	1/2000	Schorn	6,692,038	B2	2/2004	Braun
D419,861	S	2/2000	Khokhar	6,695,817	B1	2/2004	Fangrow
6,019,348	A	2/2000	Powell	6,705,591	B2	3/2004	deCler
6,024,124	A	2/2000	Braun et al.	6,722,705	B2	4/2004	Korkor
6,029,701	A	2/2000	Chaffardon et al.	6,722,708	B2	4/2004	Morohoshi et al.
6,032,691	A	3/2000	Powell et al.	6,762,365	B2	7/2004	Inoue et al.
6,041,805	A	3/2000	Gydesen et al.	6,767,017	B2	7/2004	Crapart et al.
D422,487	S	4/2000	Khokhar	D495,050	S	8/2004	Guala
6,050,297	A	4/2000	Ostrowski et al.	6,783,520	B1	8/2004	Candray et al.
6,076,234	A	6/2000	Khokhar et al.	D497,428	S	10/2004	Hayamizu
6,077,245	A	6/2000	Heinrich et al.	6,799,747	B1	10/2004	Lai
6,077,259	A	6/2000	Caizza et al.	D498,533	S	11/2004	Hayamizu
6,082,401	A	7/2000	Braun et al.	6,814,726	B1	11/2004	Lauer
6,086,044	A	7/2000	Guest	6,840,277	B1	1/2005	Nimberger
6,089,540	A	7/2000	Heinrichs et al.	6,846,021	B2	1/2005	Rohde et al.
6,099,045	A	8/2000	Pirona	6,848,602	B2	2/2005	deCler et al.
6,112,855	A	9/2000	Camacho et al.	6,848,723	B2	2/2005	Lamich
6,123,690	A	9/2000	Mejslov	6,863,314	B2	3/2005	Guest
6,135,150	A	10/2000	Powell et al.	6,871,669	B2	3/2005	Meyer et al.
6,135,992	A	10/2000	Wang	6,871,878	B2	3/2005	Miros
6,142,538	A	11/2000	Volgstadt et al.	D503,778	S	4/2005	Wicks
6,145,896	A	11/2000	Vitel et al.	6,886,803	B2	5/2005	Mikiya et al.
6,152,914	A	11/2000	Van De Kerkhof et al.	6,897,374	B2	5/2005	Garber et al.
6,155,610	A	12/2000	Godeau et al.	6,899,315	B2	5/2005	Maiville et al.
6,161,578	A	12/2000	Braun et al.	6,902,144	B2	6/2005	deCler
6,176,523	B1	1/2001	Winslett	D507,647	S	7/2005	Beck et al.
6,182,694	B1	2/2001	Sievers et al.	6,916,007	B2	7/2005	deCler et al.
6,189,560	B1	2/2001	Reynolds	6,916,050	B2	7/2005	Milhas
6,199,915	B1	3/2001	Becker	6,926,311	B2	8/2005	Chang et al.
6,199,919	B1	3/2001	Kawasaki et al.	6,929,246	B2	8/2005	Arzenton et al.
				6,945,273	B2	9/2005	Reid
				6,949,084	B2	9/2005	Marggi et al.
				6,962,275	B2	11/2005	deCler et al.
				6,978,800	B2	12/2005	deCler et al.

(56)

References Cited

U.S. PATENT DOCUMENTS

6,981,547 B2	1/2006	Maguire et al.	7,849,877 B2	12/2010	Tan et al.
6,997,486 B2	2/2006	Milhas	D630,320 S	1/2011	Lombardi, III et al.
6,997,919 B2	2/2006	Olsen et al.	D632,783 S	2/2011	Maesarapu
7,005,581 B2	2/2006	Burnette	7,878,553 B2	2/2011	Wicks et al.
7,011,342 B2	3/2006	Guivarc'h et al.	D634,840 S	3/2011	Lombardi, III et al.
7,014,214 B2	3/2006	Kaneko	D639,398 S	6/2011	Wilhelm
D522,109 S	5/2006	White et al.	7,954,374 B2	6/2011	Rankin
7,040,670 B2	5/2006	Madden	7,954,515 B2	6/2011	Gerst
7,044,161 B2	5/2006	Tiberghien	D642,244 S	7/2011	Wilhelm
7,044,506 B2	5/2006	Dong	7,976,071 B2	7/2011	Bibby
D523,553 S	6/2006	Beck et al.	D645,547 S	9/2011	Lombardi, III et al.
7,080,665 B2	7/2006	Whall	D649,240 S	11/2011	Lewis et al.
7,081,223 B2	7/2006	Khoury	D650,478 S	12/2011	Lewis
7,108,297 B2	9/2006	Takayanagi et al.	D652,510 S	1/2012	Lombardi, III et al.
7,118,138 B1	10/2006	Rowley et al.	D652,511 S	1/2012	Lombardi, III et al.
7,128,348 B2	10/2006	Kawamura et al.	D654,573 S	2/2012	Lombardi, III et al.
7,137,654 B2	11/2006	Segal et al.	8,113,546 B2	2/2012	Jensen et al.
7,140,592 B2	11/2006	Phillips	D655,393 S	3/2012	Whitaker
7,147,252 B2	12/2006	Teuscher et al.	D661,388 S *	6/2012	Clark D24/130
7,150,478 B2	12/2006	Poirier et al.	8,235,971 B2 *	8/2012	Christensen et al. 604/533
7,153,296 B2	12/2006	Mitchell	8,282,134 B2 *	10/2012	Cavagna 285/319
7,163,022 B2	1/2007	Whall	8,287,518 B2 *	10/2012	Kitani et al. 604/533
D540,944 S	4/2007	Guala	8,348,928 B2 *	1/2013	Guala 604/533
7,210,917 B2	5/2007	Lai et al.	8,357,142 B2 *	1/2013	Romero 604/533
D547,446 S	7/2007	Racz et al.	8,372,059 B2 *	2/2013	Ziman 604/533
D550,355 S	9/2007	Racz et al.	8,419,714 B2 *	4/2013	Webler et al. 604/538
D557,409 S	12/2007	Veliss et al.	D682,422 S *	5/2013	Anderson et al. D24/130
7,316,428 B2	1/2008	Takayanagi et al.	8,454,059 B2 *	6/2013	Stell 285/315
D564,660 S	3/2008	Hayashi	8,469,405 B2 *	6/2013	Wheatley et al. 285/314
7,343,931 B2	3/2008	Packham	8,486,049 B2 *	7/2013	Guala 604/533
D567,340 S	4/2008	Tiberghien	8,500,715 B2 *	8/2013	Racz et al. 604/533
7,352,771 B2	4/2008	Garber	2001/0017466 A1	8/2001	Braun
D569,507 S	5/2008	Blanchard	2002/0022762 A1	2/2002	Beane et al.
D569,955 S	5/2008	Chen	2002/0070547 A1	6/2002	Guertin
7,377,553 B2	5/2008	Takayanagi	2002/0093192 A1	7/2002	Matkovich
D570,457 S	6/2008	Brown	2002/0140172 A1	10/2002	Platusich
7,390,029 B2	6/2008	Matsubara	2002/0156344 A1	10/2002	Pasricha et al.
7,394,375 B2	7/2008	Johnson	2002/0185861 A1	12/2002	Inoue
7,434,842 B2	10/2008	Schmidt	2003/0004397 A1	1/2003	Kameya et al.
7,434,846 B2	10/2008	Baumgartner	2003/0067162 A1	4/2003	Welsh et al.
7,448,653 B2	11/2008	Jensen et al.	2003/0193188 A1	10/2003	Miros
7,464,970 B2	12/2008	Yamada et al.	2003/0230894 A1	12/2003	Cleveland et al.
7,467,813 B2	12/2008	Gunderson	2004/0021318 A1	2/2004	Fritze et al.
7,469,472 B2	12/2008	DeCler et al.	2004/0056484 A1	3/2004	Kwon et al.
7,478,840 B2	1/2009	Youssefifar	2004/0094903 A1	5/2004	Sutherland
7,488,446 B2	2/2009	Meyer et al.	2004/0195830 A1	10/2004	Gilmour
7,494,156 B2	2/2009	Okada	2004/0199143 A1	10/2004	Lauer
7,503,595 B2	3/2009	McKay	2004/0227346 A1	11/2004	Jamison et al.
7,516,990 B2	4/2009	Jamison et al.	2004/0232696 A1	11/2004	Andre
7,546,857 B2	6/2009	Chadbourne et al.	2005/0033237 A1	2/2005	Fentress et al.
7,547,047 B2	6/2009	deCler et al.	2005/0046184 A1	3/2005	Chang
D595,845 S	7/2009	Miros et al.	2005/0057042 A1	3/2005	Wicks
D595,846 S	7/2009	Racz et al.	2005/0082828 A1	4/2005	Wicks et al.
D596,288 S	7/2009	Racz et al.	2005/0087981 A1	4/2005	Yamada et al.
D596,739 S	7/2009	Ng et al.	2005/0209583 A1	9/2005	Powers et al.
7,562,906 B2	7/2009	Schmidt	2005/0217265 A1	10/2005	Popp et al.
7,566,077 B2	7/2009	Tsurumi	2005/0242579 A1	11/2005	Bright et al.
7,581,763 B2	9/2009	Salomon-Bahls	2005/0275220 A1	12/2005	Shu
D602,128 S	10/2009	Williams et al.	2006/0066100 A1	3/2006	Nakashima et al.
7,614,666 B2	11/2009	Eggert et al.	2006/0152003 A1	7/2006	Slunick et al.
7,631,660 B2	12/2009	deCler et al.	2006/0202146 A1	9/2006	Doyle
7,647,954 B2	1/2010	Garber et al.	2006/0264814 A1	11/2006	Sage
7,666,178 B2	2/2010	McMichael	2006/0293629 A1	12/2006	Cote, Sr. et al.
D612,019 S	3/2010	Williams et al.	2007/0025811 A1	2/2007	Wilhelm
D612,021 S	3/2010	Schmidt	2007/0029795 A1	2/2007	Moner et al.
7,677,608 B2	3/2010	Takayanagi	2007/0029796 A1	2/2007	Bibby
D613,853 S	4/2010	Ng et al.	2007/0106213 A1	5/2007	Spera et al.
7,695,020 B2	4/2010	Schmidt	2007/0137718 A1	6/2007	Rushlander et al.
7,708,025 B2	5/2010	Johnson	2007/0169825 A1	7/2007	Packham et al.
7,731,244 B2	6/2010	Miros et al.	2007/0209716 A1	9/2007	Rankin
D619,706 S	7/2010	Schon et al.	2007/0284875 A1	12/2007	Salomon-Bahls et al.
7,770,939 B2	8/2010	Jensen et al.	2008/0007051 A1	1/2008	Jensen et al.
7,806,139 B2	10/2010	Packham et al.	2008/0011703 A1	1/2008	Schmeisser et al.
7,841,357 B2	11/2010	Rankin	2008/0012314 A1	1/2008	Harger et al.
D629,894 S	12/2010	Lombardi, III et al.	2008/0018105 A1	1/2008	Le Bars
			2008/0048448 A1	2/2008	Jamison et al.
			2008/0078464 A1	4/2008	Loewe
			2008/0111371 A1	5/2008	Feger et al.
			2008/0111372 A1	5/2008	Trede et al.

(56)

References Cited

U.S. PATENT DOCUMENTS

2008/0129047 A1 6/2008 Blivet et al.
 2008/0164694 A1 7/2008 Zdroik et al.
 2008/0191466 A1 8/2008 Knipple et al.
 2008/0200901 A1 8/2008 Rasmussen et al.
 2008/0277923 A1 11/2008 Brandt et al.
 2008/0277924 A1 11/2008 Jensen et al.
 2008/0284167 A1 11/2008 Lim et al.
 2008/0287920 A1 11/2008 Fangrow et al.
 2009/0079187 A1 3/2009 Malone
 2009/0127847 A1 5/2009 Hagen et al.
 2009/0129047 A1 5/2009 Park et al.
 2009/0140519 A1 6/2009 Pavnaskar et al.
 2009/0167018 A1 7/2009 Lien
 2009/0187166 A1 7/2009 Young
 2009/0188575 A1 7/2009 Williams et al.
 2009/0256355 A1 10/2009 Wicks et al.
 2010/0001516 A1 1/2010 Pisula, Jr. et al.
 2010/0056975 A1 3/2010 Dale et al.
 2010/0078934 A1 4/2010 Matsunaga
 2010/0185040 A1 7/2010 Uber et al.
 2010/0194100 A1 8/2010 Koch
 2010/0276922 A1 11/2010 Rehder et al.
 2010/0295295 A1 11/2010 Schmidt
 2010/0301599 A1 12/2010 Jensen et al.
 2010/0319796 A1 12/2010 Whitaker
 2011/0012340 A1 1/2011 Packham et al.
 2011/0127767 A1 6/2011 Wicks et al.
 2011/0204621 A1 8/2011 Whitaker et al.
 2011/0204622 A1 8/2011 Lewis et al.
 2011/0210541 A1 9/2011 Lewis et al.
 2012/0031515 A1 2/2012 Whitaker
 2012/0068457 A1 3/2012 Pisula, Jr. et al.

FOREIGN PATENT DOCUMENTS

DE 3439522 8/1985
 DE 3533000 3/1987
 DE 4122455 1/1993
 DE 19800050 7/1998
 DE 102005015343 10/2006
 EP 0360634 3/1990
 EP 0390746 10/1990
 EP 0267067 7/1991
 EP 0482277 4/1992
 EP 0592823 4/1994
 EP 0715111 6/1996
 EP 0865779 9/1998
 EP 0877891 11/1998
 EP 0890054 1/1999
 EP 0982525 3/2000
 EP 1497582 1/2005
 EP 1564469 8/2005
 EP 1843074 10/2007
 FR 2031965 11/1970
 FR 2429370 1/1980
 FR 280871 10/2001
 FR 2853043 10/2004
 FR 2870921 12/2005
 FR 2903164 1/2008
 GB 583459 12/1946
 GB 890775 3/1962
 GB 2177769 1/1987
 GB 2218166 11/1989
 GB 2271157 4/1994
 GB 2379253 3/2003
 JP 53-006918 1/1978
 JP 5-223189 8/1993
 JP 7-145889 6/1995
 JP 10-169869 6/1998
 JP 11-82849 3/1999

JP 2003-42363 2/2003
 JP 2003-42368 2/2003
 WO WO 93/17270 9/1993
 WO WO 95/08732 3/1995
 WO WO 00/079172 12/2000
 WO WO 2004/104466 12/2004
 WO WO 2005/064216 7/2005
 WO WO 2006/031958 3/2006
 WO WO 2006/073778 7/2006
 WO WO 2006/084171 8/2006
 WO WO 2006/135666 12/2006
 WO WO 2007/038222 4/2007
 WO WO 2007/116387 10/2007
 WO WO 2007/120620 10/2007
 WO WO 2008/023021 2/2008
 WO WO 2009/026441 2/2009

OTHER PUBLICATIONS

U.S. Appl. No. 29/385,360, filed Feb. 11, 2011, Lombardi et al., Pending.
 U.S. Appl. No. 29/385,363, filed Feb. 11, 2011, Lombardi et al., Pending.
 U.S. Appl. No. 29/398,433, filed Jul. 29, 2011, Lombardi et al., Pending.
 U.S. Appl. No. 29/398,440, filed Jul. 29, 2011, Lombardi et al., Pending.
 U.S. Appl. No. 13/265,191, filed Oct. 19, 2011, Pisula, Jr. et al., Pending.
 About Us [online], Thuro Metal Products [retrieved on Apr. 9, 2010], retrieved from the Internet: <URL: <http://www.thurometal.com/about.html>>, 2 pages.
 Barbed Tee Adapter, 1/2 in to 3/8 in to 1/2 in [Item # F1728], http://www.horticulturesource.com/product_info.php/products_id/4016/language/en; dated accessed Sep. 14, 2009, 3 pages.
 Brochure, "Precision Components", Value Plastics, Inc., 2002, 132 pages.
 Capabilities [online], Jay Manufacturing Corp., retrieved on Apr. 9, 2010, retrieved from the Internet: <URL: <http://www.jaymfg.com/capabilities.htm>>, 2 pages.
 Flojet "Quick Connect" Port System Adapter 90 Elbow Type Quad Port X 1/2" Hose Barb, http://www.amazon.com/Quick-Connect-Port-System-Quad-Barb-90/dp/B0000AZ771/ref=sr_1_16?s=sporting-goods&ie=UTF8&qid=1300220596&sr=1-16, date accessed Sep. 14, 2009; 3 pages.
 High-Flow Quick Disconnect Couplings; http://www.coleparmer.com/catalog/product_view.asp?sku=3130355; date accessed Sep. 14, 2009, 3 pages.
 Mills, The Process of Vacuum-forming Plastic Parts, IPFrontline.com [online], retrieved on Apr. 9, 2010, retrieved from the Internet: <URL: <http://www.ipfrontline.com/depts/article.asp?id=453&deptid=2>>, 3 pages.
 Nylon, Polypropylene Kynar (PVDF) Plastic Fittings for Flexible Tubing & Hose, http://www.omega.com/pdf/tubing/fittings_tubing_hose/nylon_poly_kynar/nylon.asp; dated accessed Sep. 14, 2009, 2 pages.
 Science of Hose Barbs, Colder Products Company, <http://www.pddnet.com/article-the-science-of-hose-barbs/>, date accessed Sep. 4, 2009, 6 pages.
 Stackable Hose Barb Elbow—1/2" CTS x 1/2 ID Barb, http://www.freshwatersystems.com/p-1714-stackable-hose-barb-elbow-12-cts-x-12-id-barb.aspx?affiliated=10052&utm_source=shopzilla&utm_medium=Feed&utm_campaign=Product&utm_term=3512-1008, date accessed Sep. 14, 2009, 1 page.
 Stainless Steel Overview: History [online], Stainless Steel Industry of North America, retrieved on Apr. 9, 2010, retrieved from the Internet: <URL: <http://www.ssina.com/overview/history.html>>, 1 page.

* cited by examiner

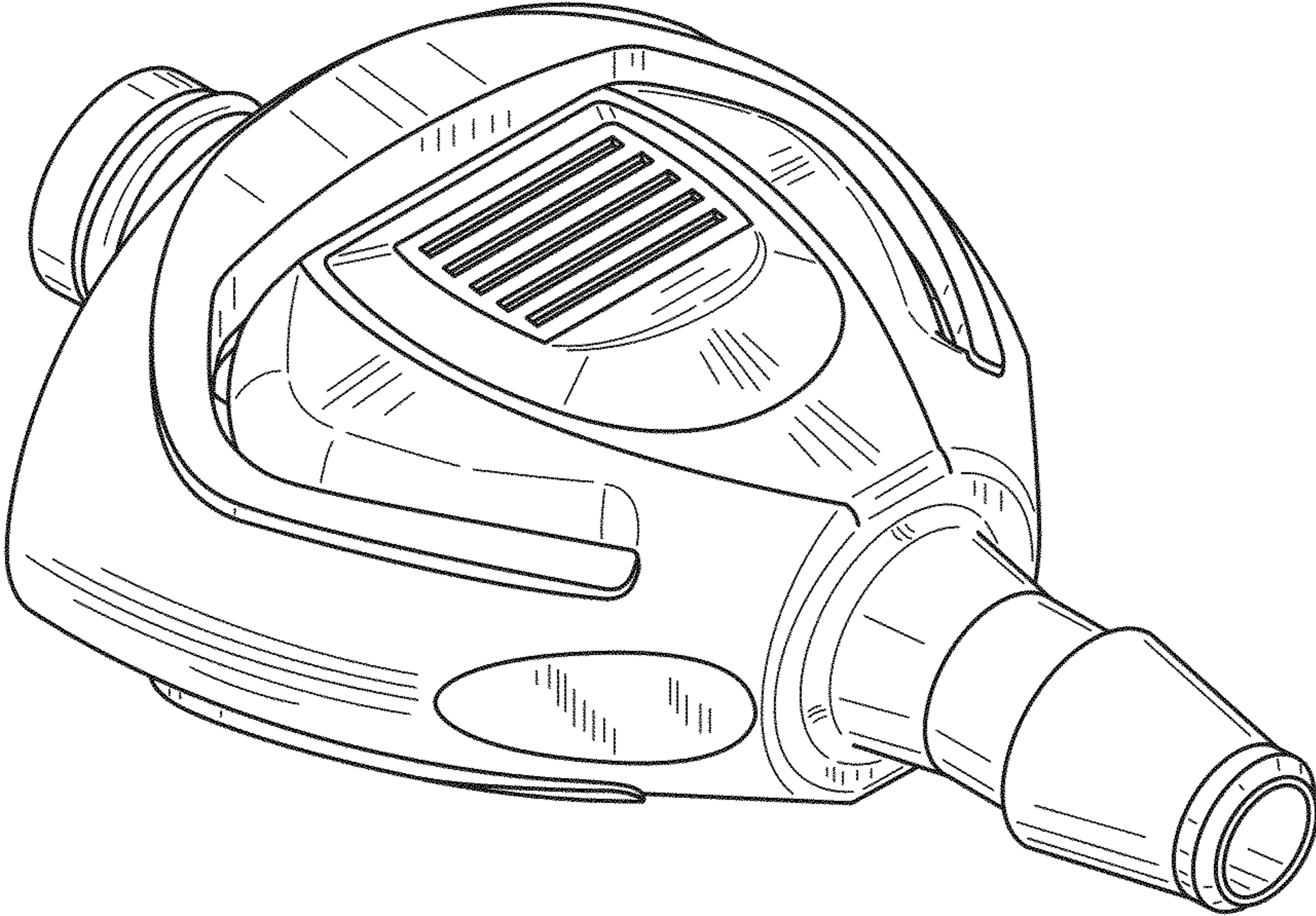

FIG.1

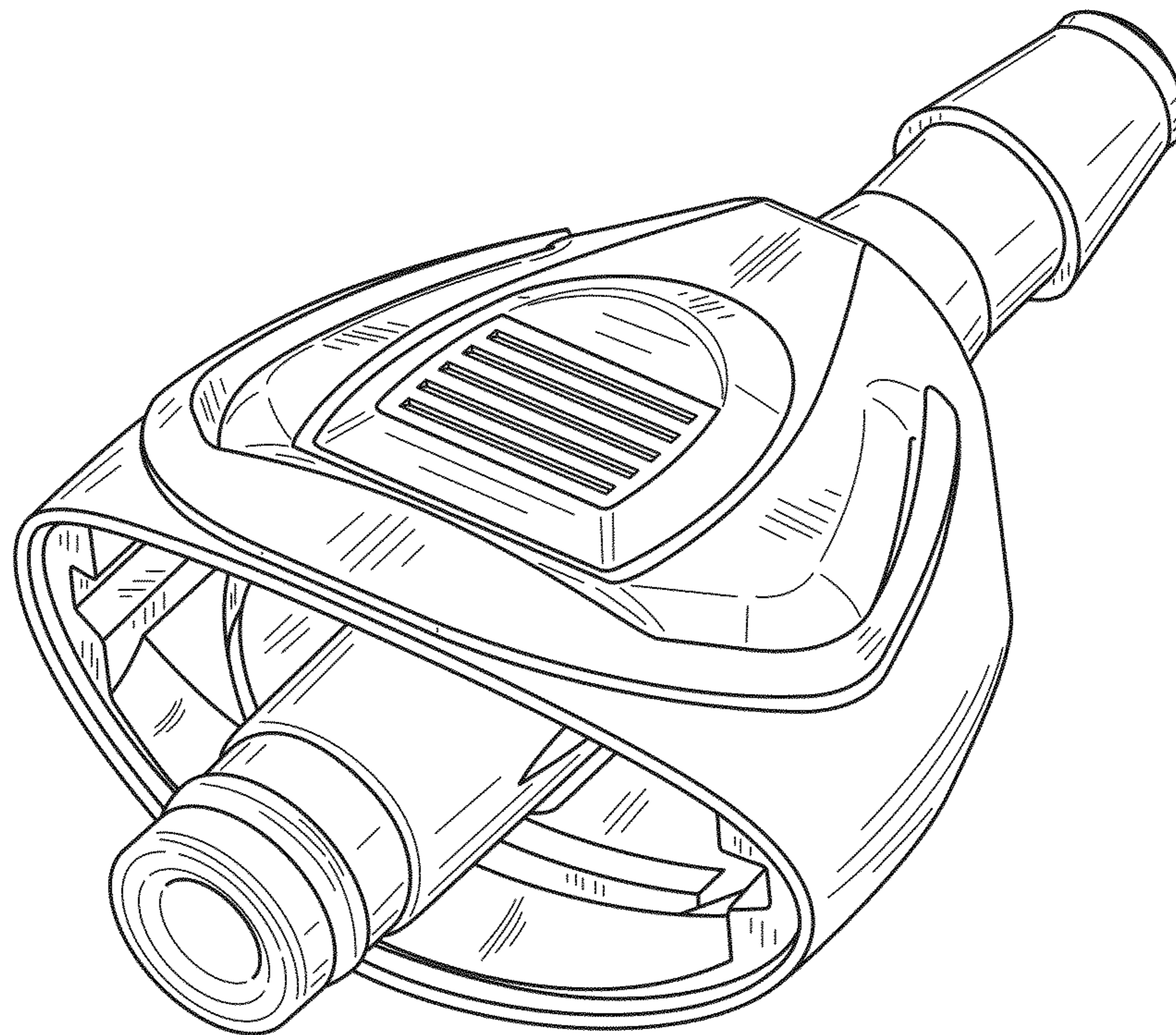

FIG.2

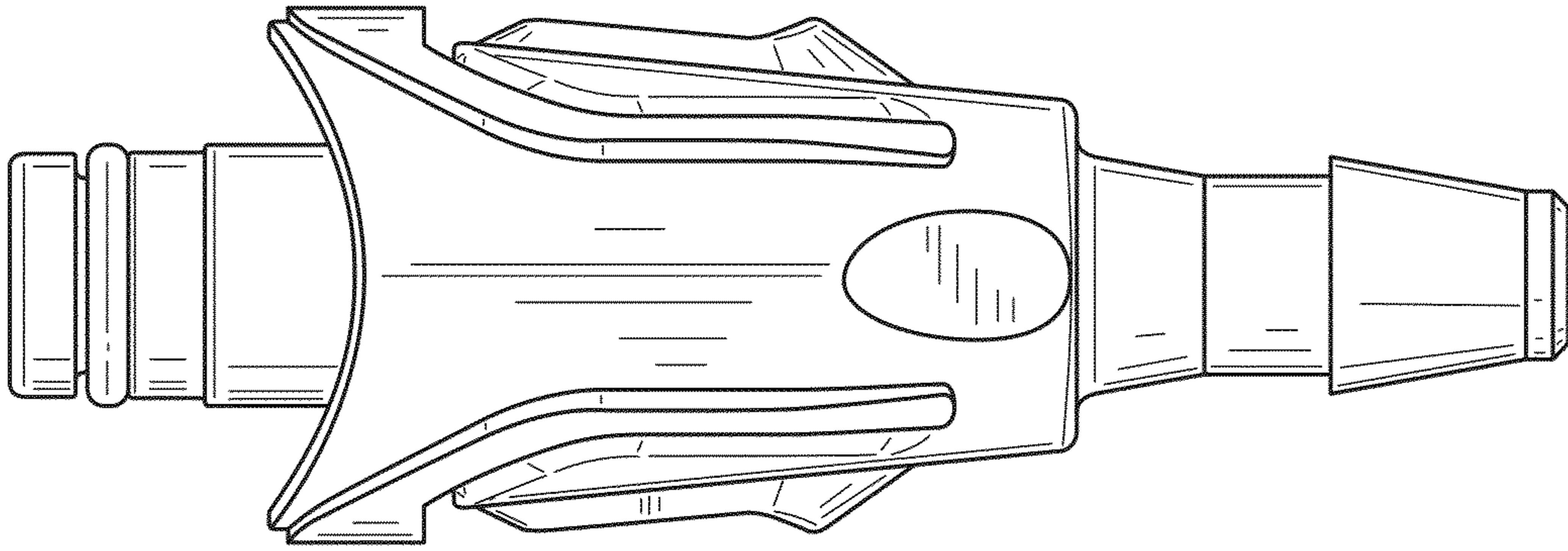

FIG.3

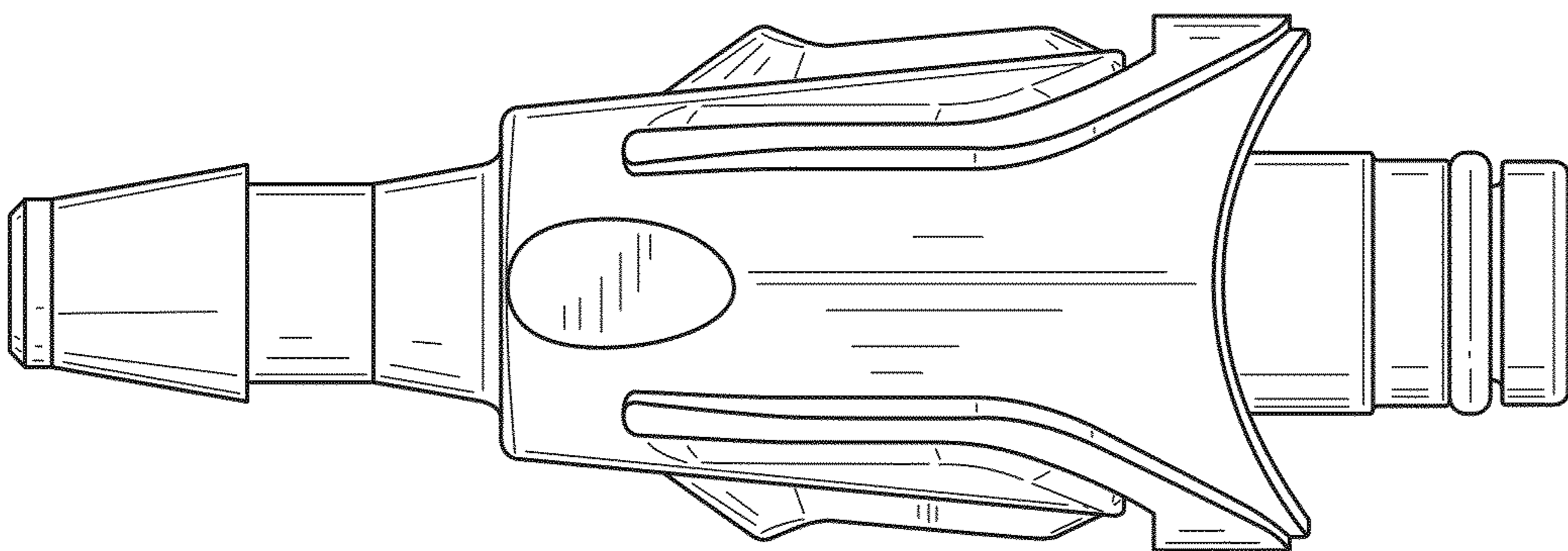

FIG.4

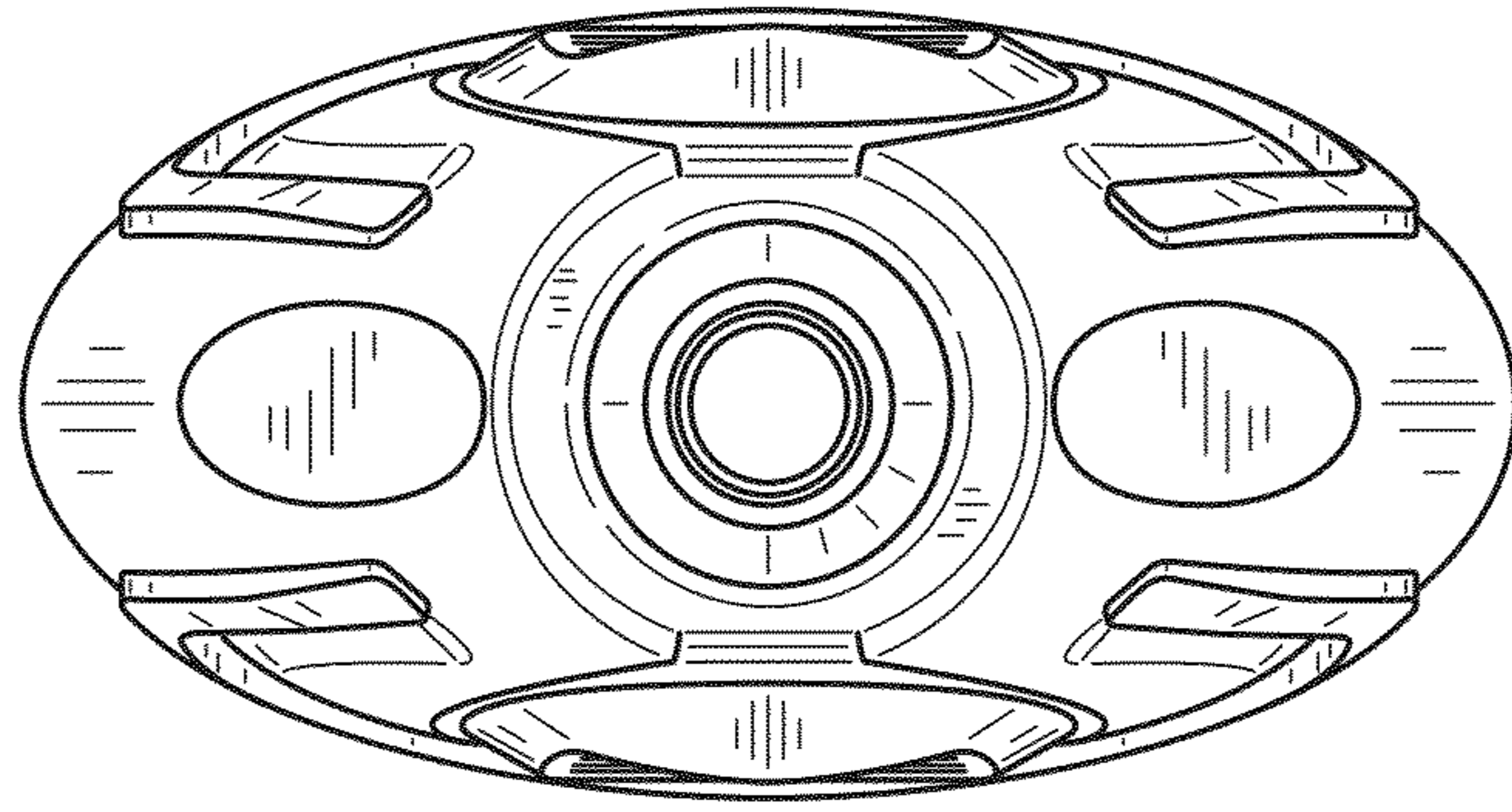

FIG. 5

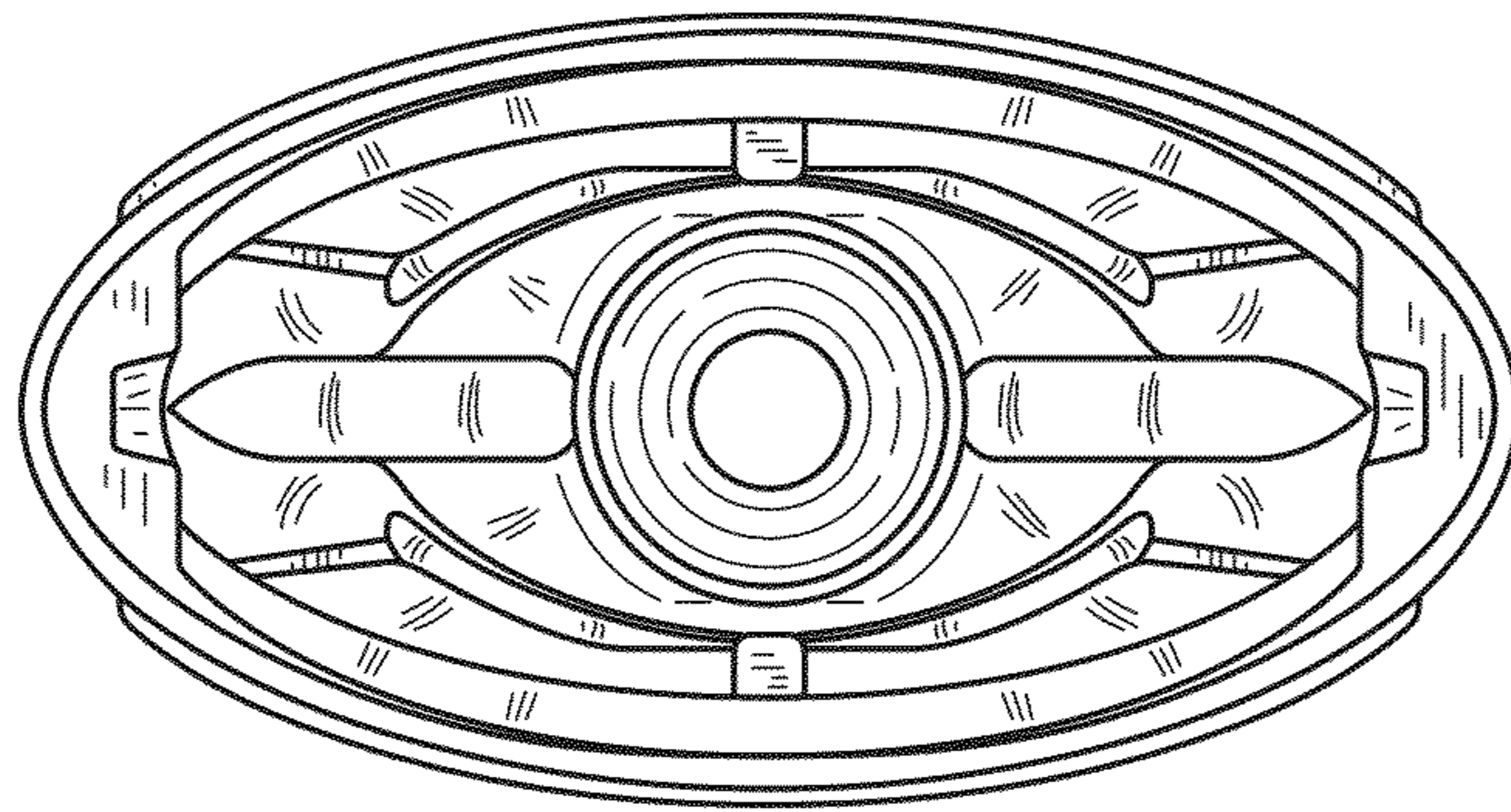

FIG. 6

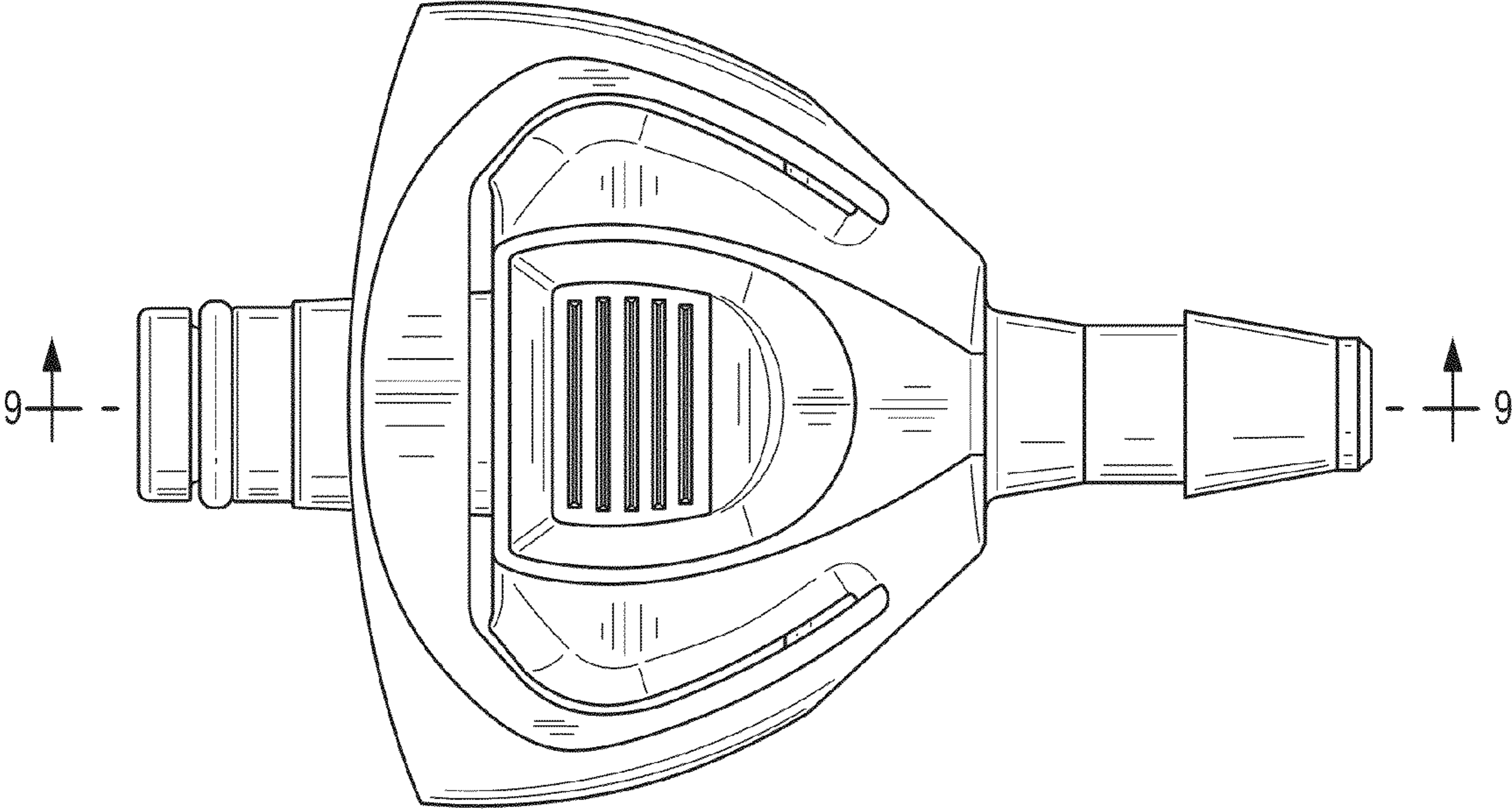

FIG. 7

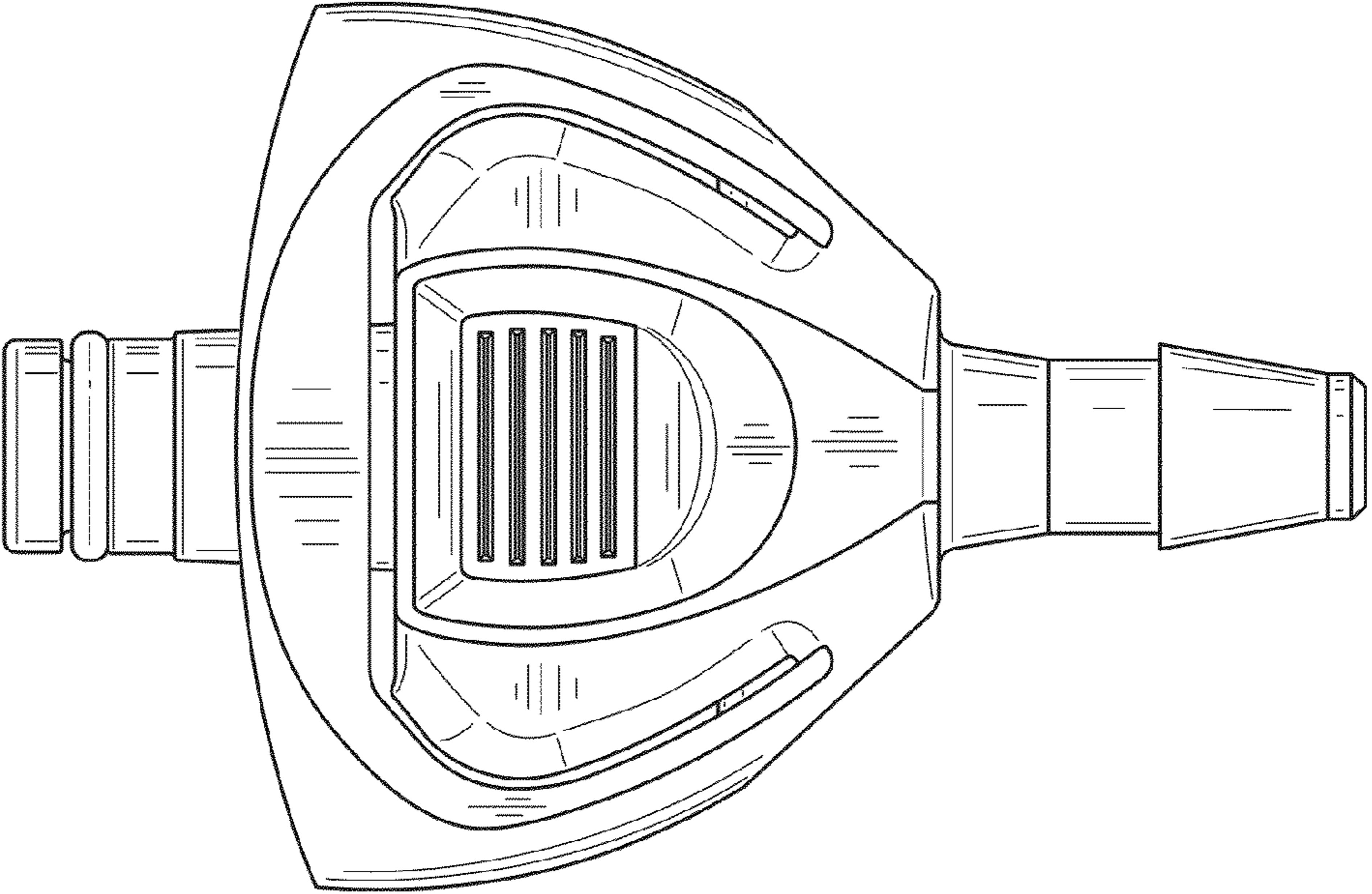

FIG. 8

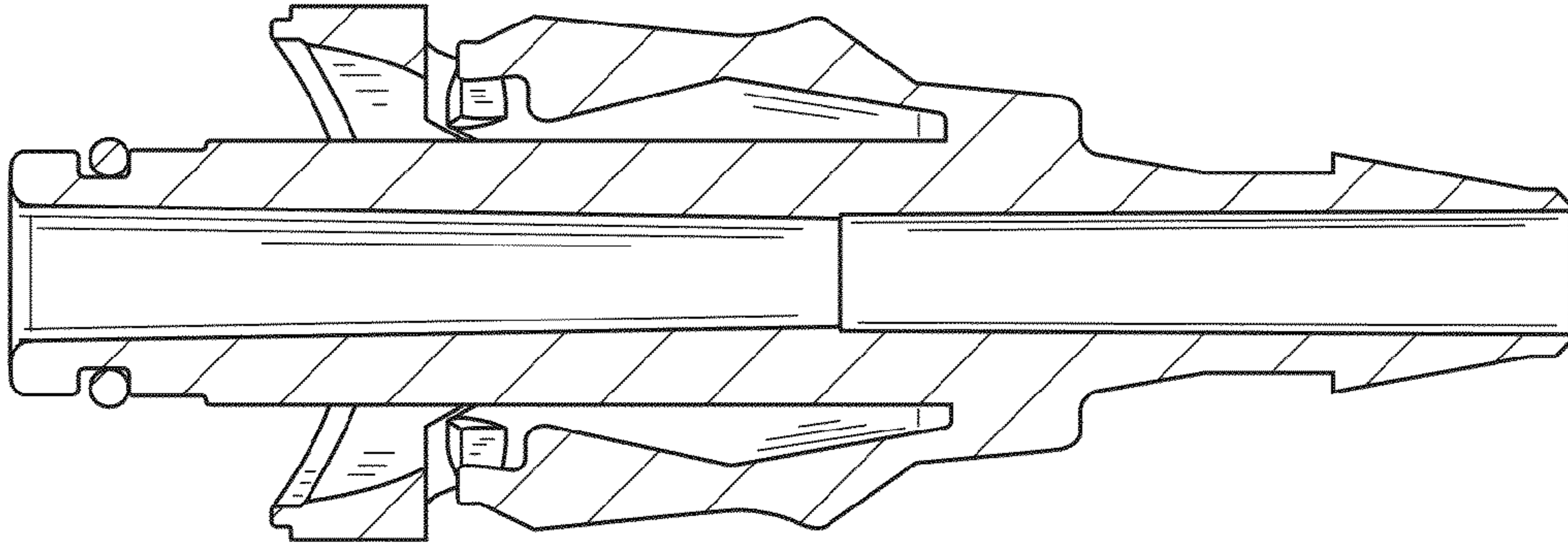

FIG. 9

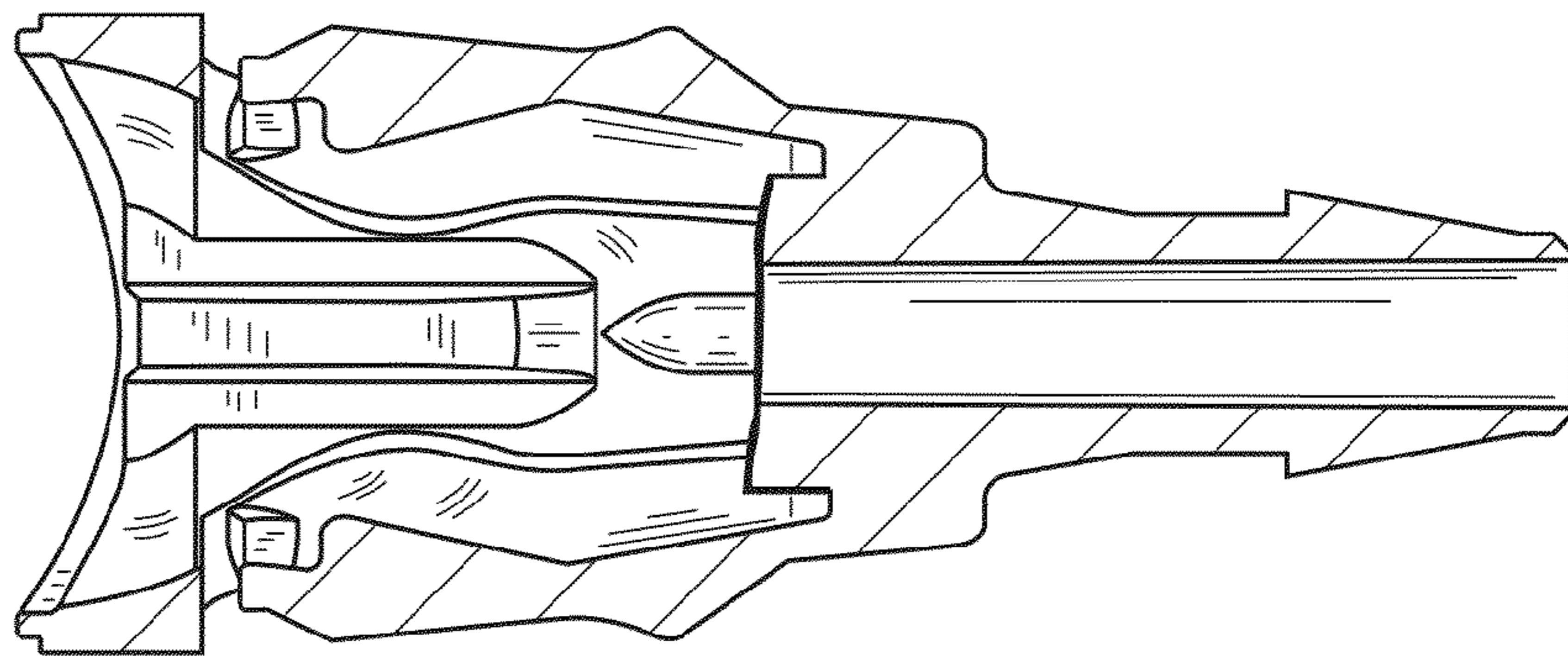

FIG. 10