



US00D699708S

(12) **United States Design Patent**  
**Files**

(10) **Patent No.:** **US D699,708 S**  
(45) **Date of Patent:** **\*\* Feb. 18, 2014**

- (54) **SADDLEBAG LID SPEAKER HOUSING FOR A MOTORCYCLE**
- (76) Inventor: **Edward M. Files**, Lee's Summit, MO (US)
- (\*\*) Term: **14 Years**
- (21) Appl. No.: **29/430,457**
- (22) Filed: **Aug. 25, 2012**
- (51) **LOC (10) Cl.** ..... **14-03**
- (52) **U.S. Cl.**  
USPC ..... **D14/214; D12/114**
- (58) **Field of Classification Search**  
USPC ..... D14/172, 194, 196, 204, 207, 209.1, D14/210-217, 219-222, 224; 181/143, 144, 181/147, 148, 150, 153, 157, 198, 199; 381/300-303, 306, 332, 333, 336, 345, 381/361-364, 386-388; D12/114, 119  
See application file for complete search history.

D372,918 S *	8/1996	Manganese et al.	.....	D14/214
D450,632 S *	11/2001	Morgan	.....	D12/114
D546,318 S *	7/2007	Yoon et al.	.....	D14/214
D625,708 S *	10/2010	Files	.....	D14/214

\* cited by examiner

*Primary Examiner* — Keli L Hill  
(74) *Attorney, Agent, or Firm* — Erickson, Kernell, Derusseau & Kleypas, LLC

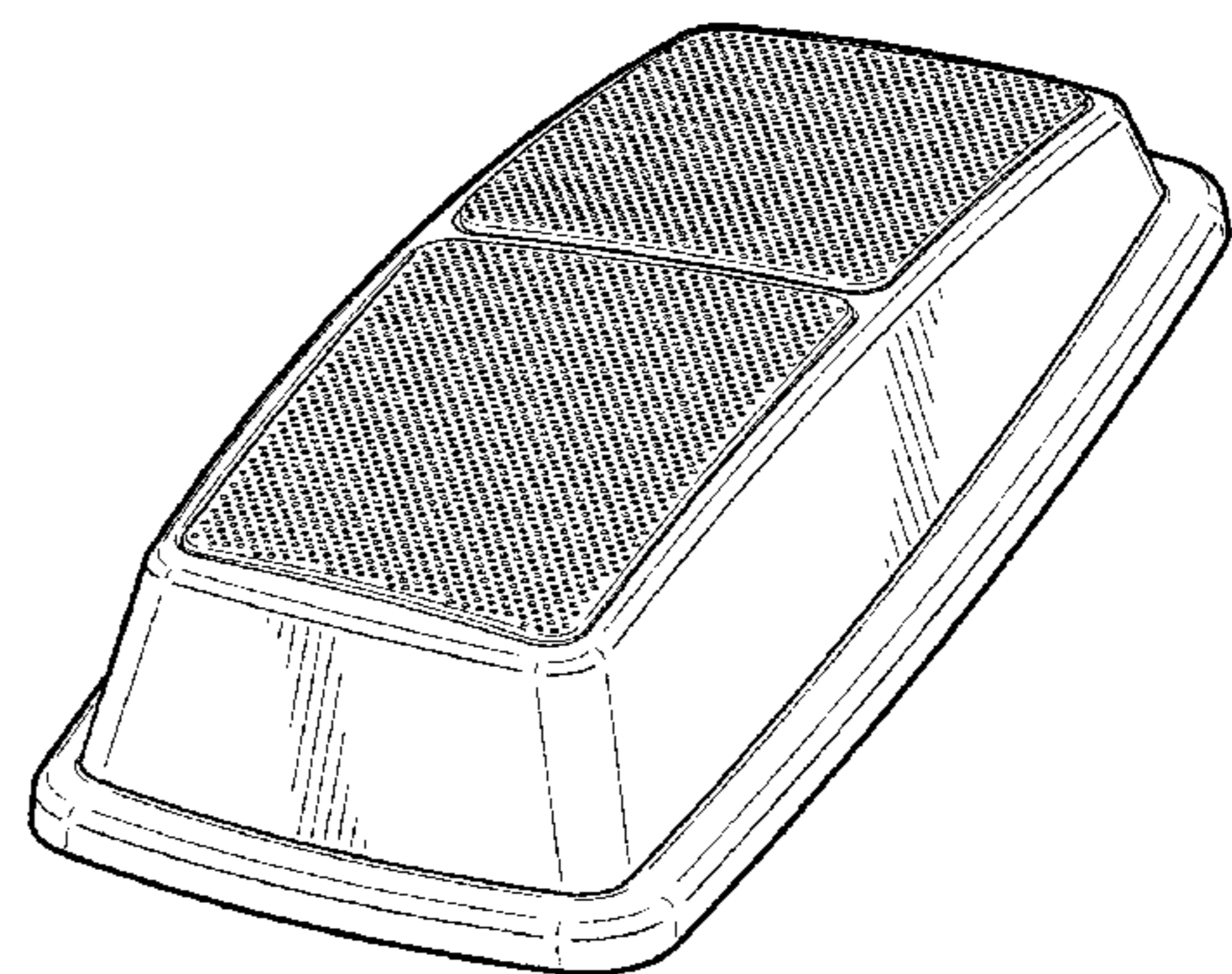
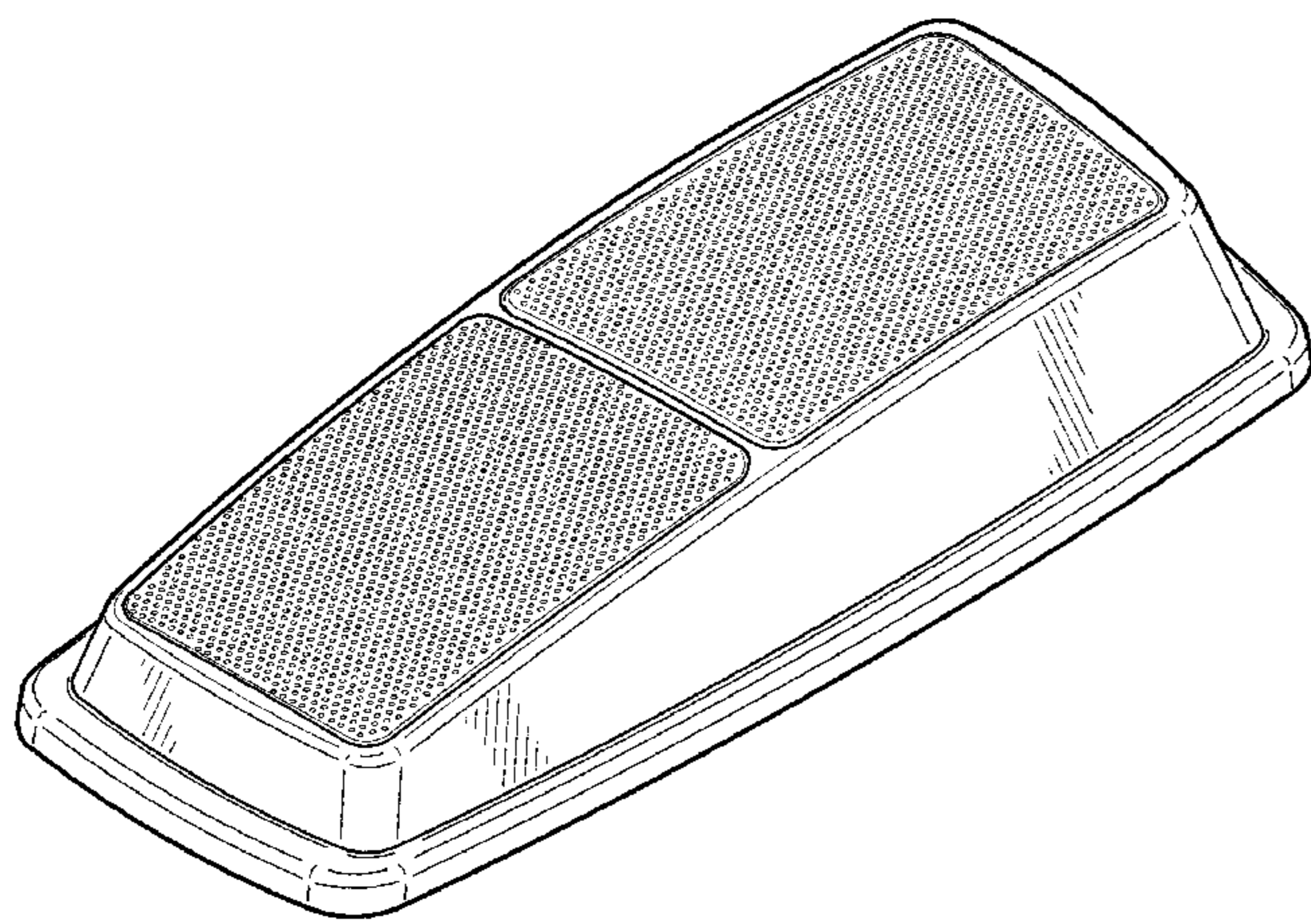
(57) **CLAIM**  
The ornamental design for a saddlebag lid speaker housing for a motorcycle, as shown and described.

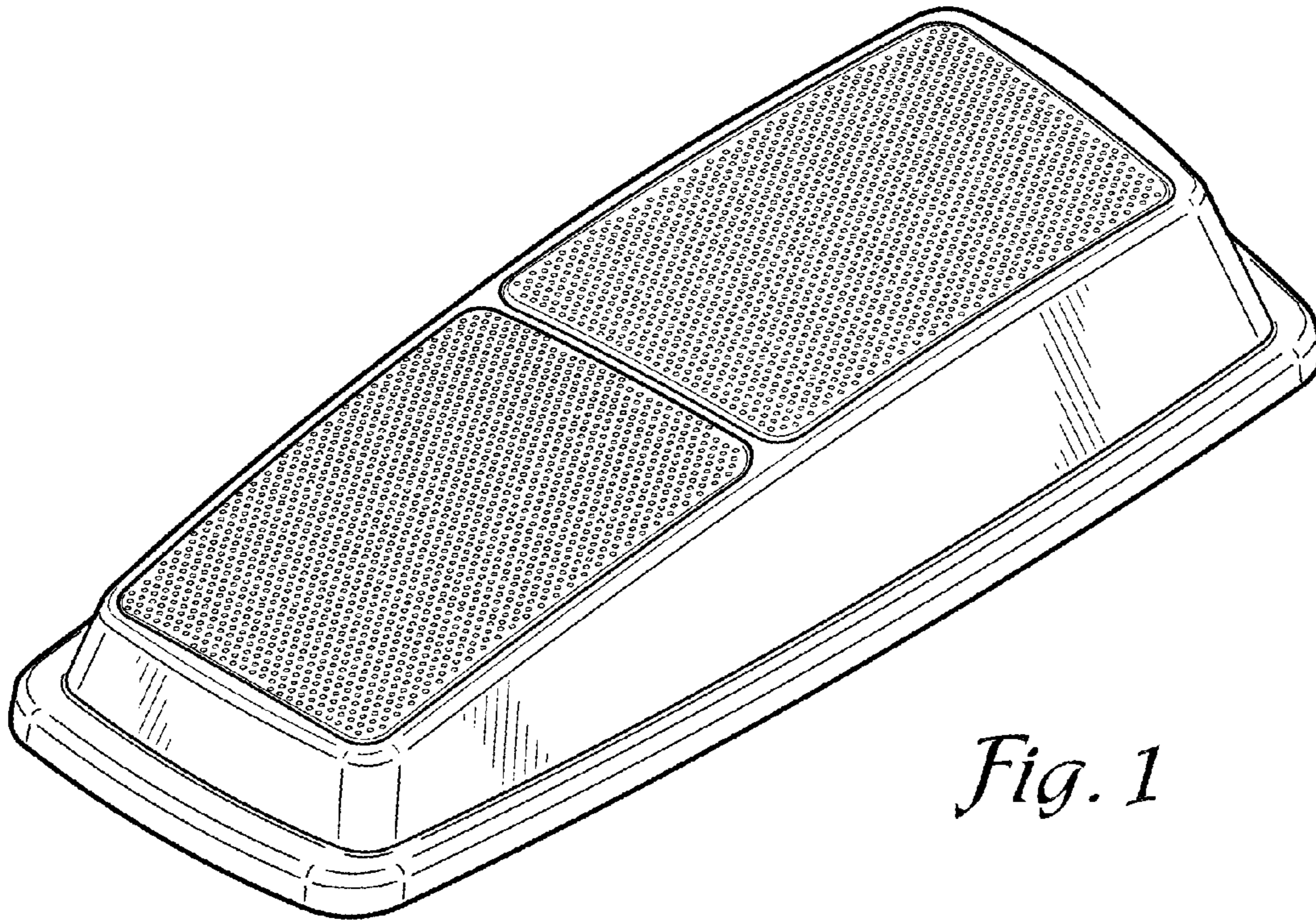
**DESCRIPTION**

FIG. 1 is a right front perspective view of a saddlebag lid speaker housing for a motorcycle according to the present invention;  
FIG. 2 is a left rear perspective view thereof;  
FIG. 3 is a top plan view thereof;  
FIG. 4 is a left side elevational view thereof;  
FIG. 5 is a bottom plan view thereof and includes a pair of audio speakers which are shown in broken lines and forms no part of the claimed design;  
FIG. 6 is a right side elevational view thereof;  
FIG. 7 is a rear elevational view thereof; and,  
FIG. 8 is a front elevational view thereof.

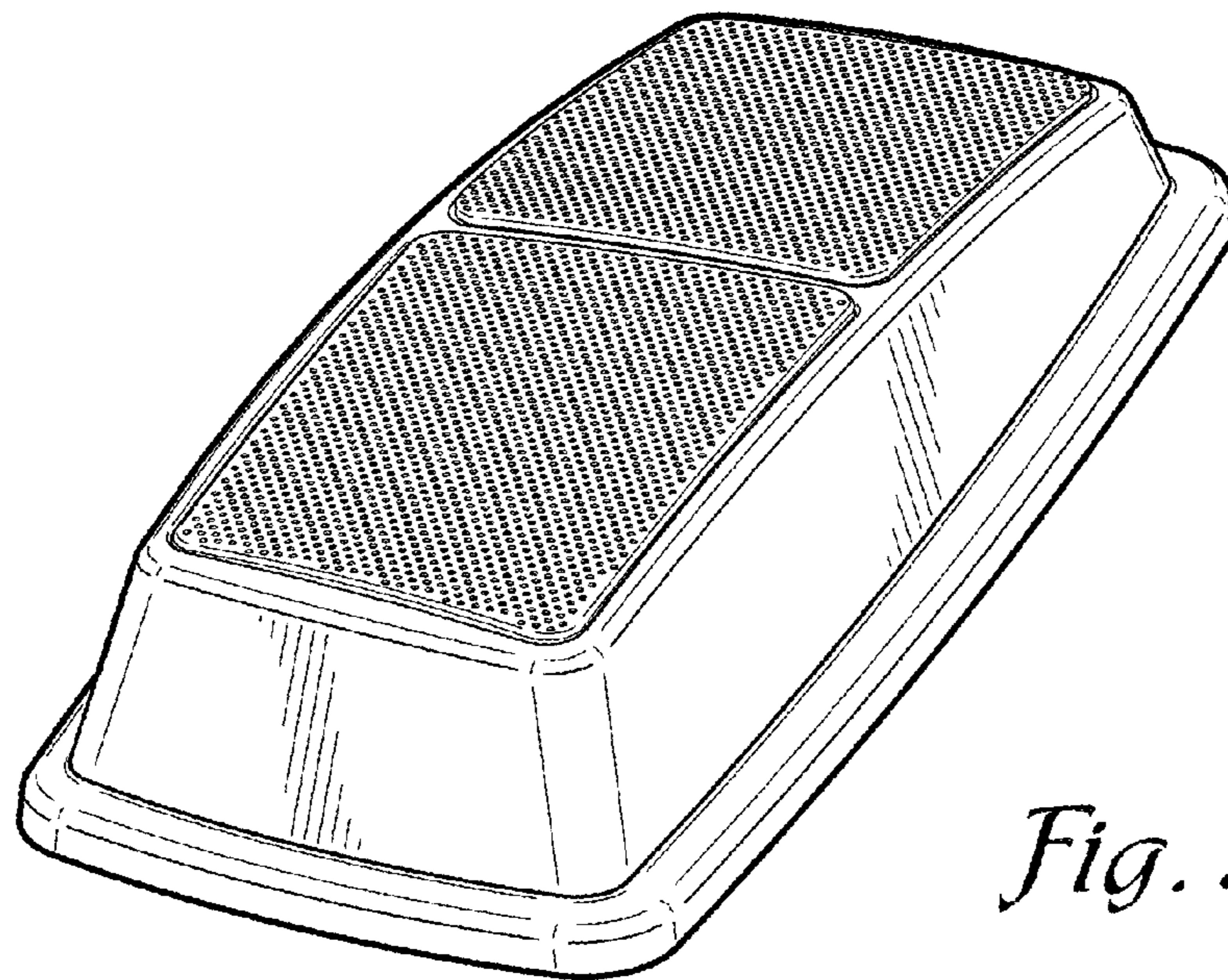
**1 Claim, 3 Drawing Sheets**

- (56) **References Cited**  
U.S. PATENT DOCUMENTS  
D178,027 S \* 6/1956 Viemeister ..... D12/126  
D200,144 S \* 1/1965 Marchello ..... D12/401  
D252,328 S \* 7/1979 Moore, Sr. .... D12/218  
4,582,162 A \* 4/1986 Katsuno ..... 181/141  
D356,301 S \* 3/1995 Schneider et al. .... D14/189

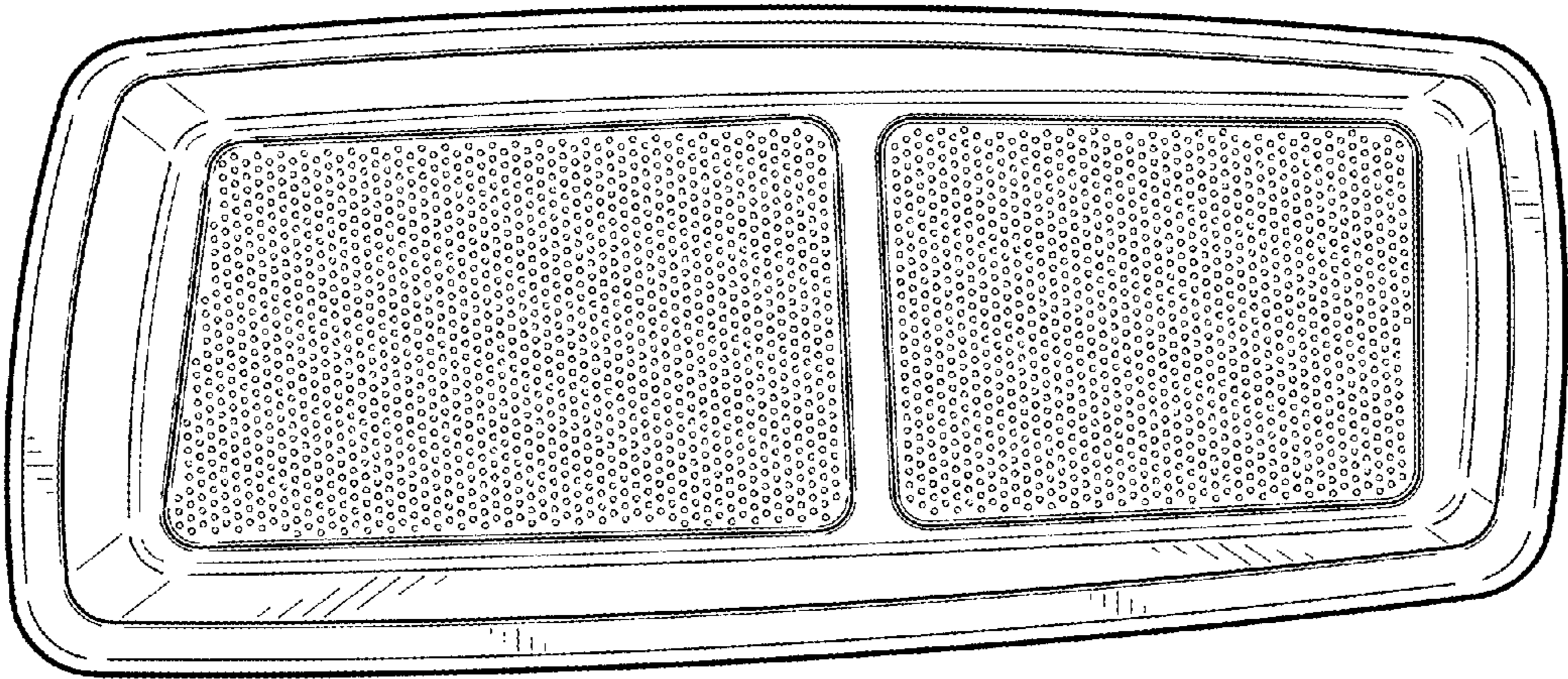




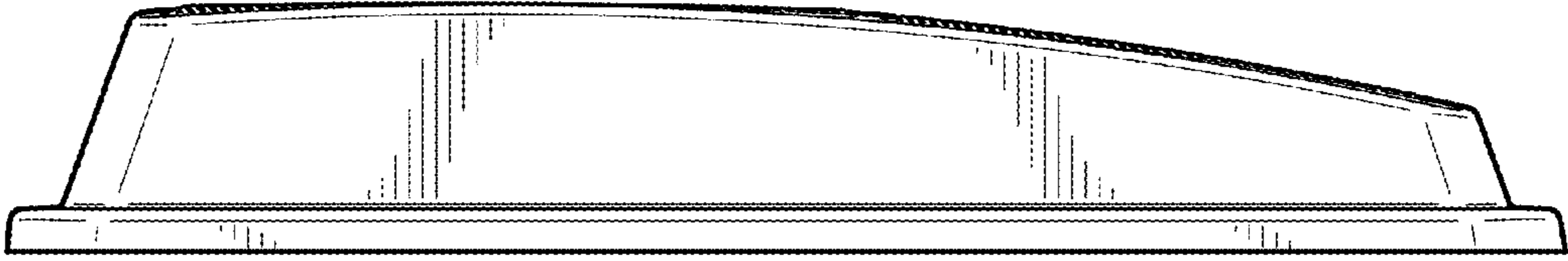
*Fig. 1*



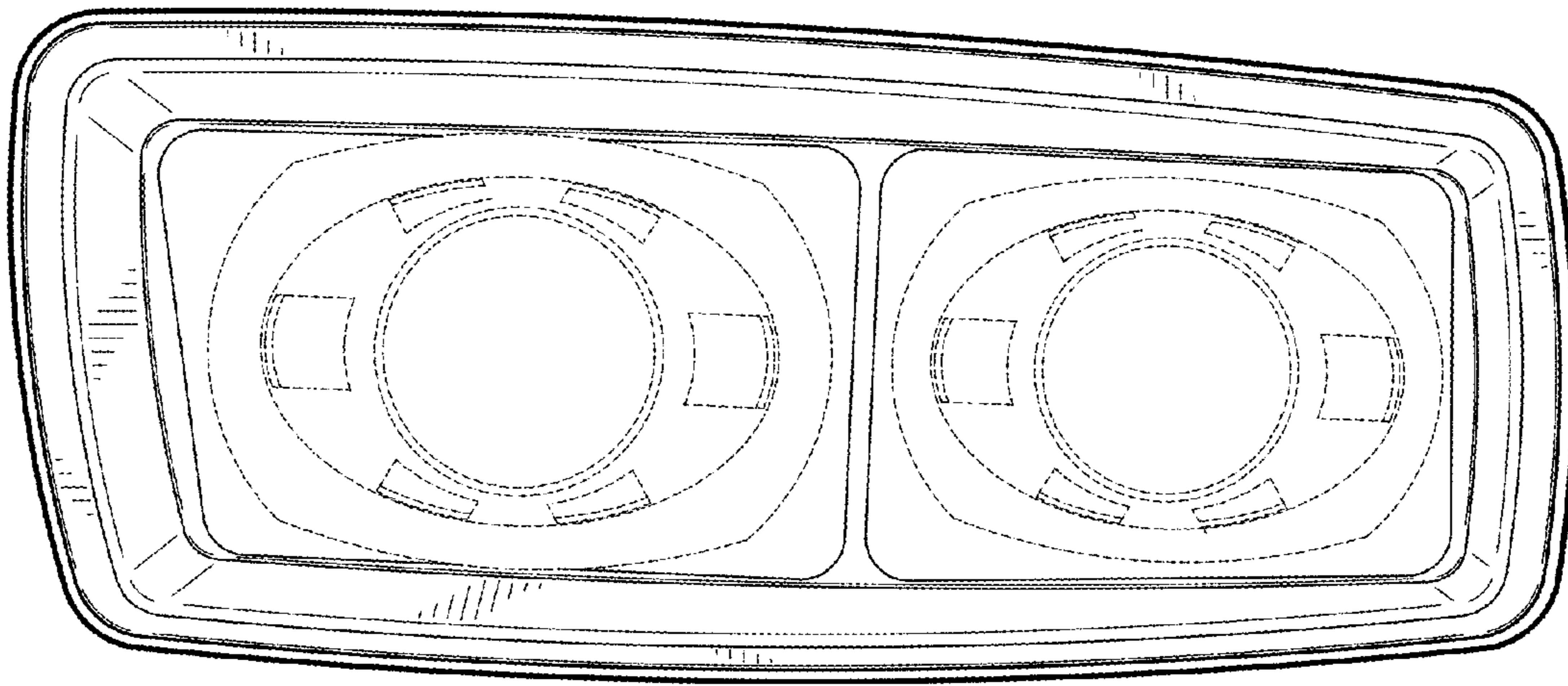
*Fig. 2*



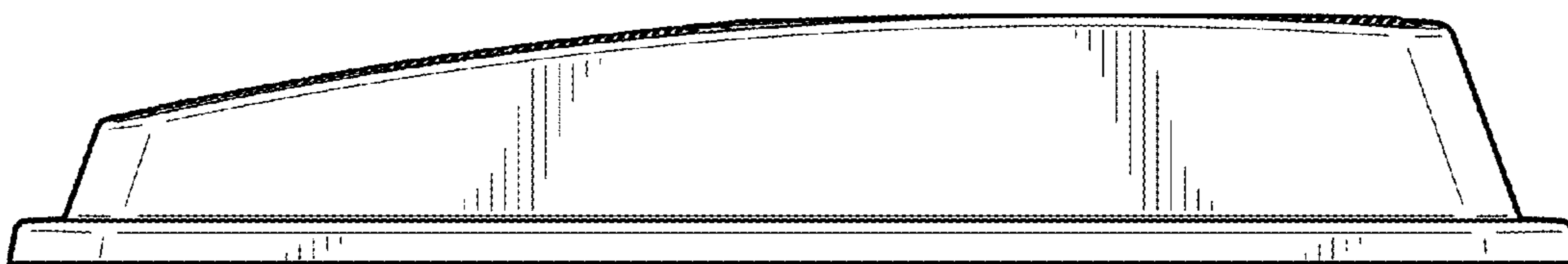
*Fig. 3*



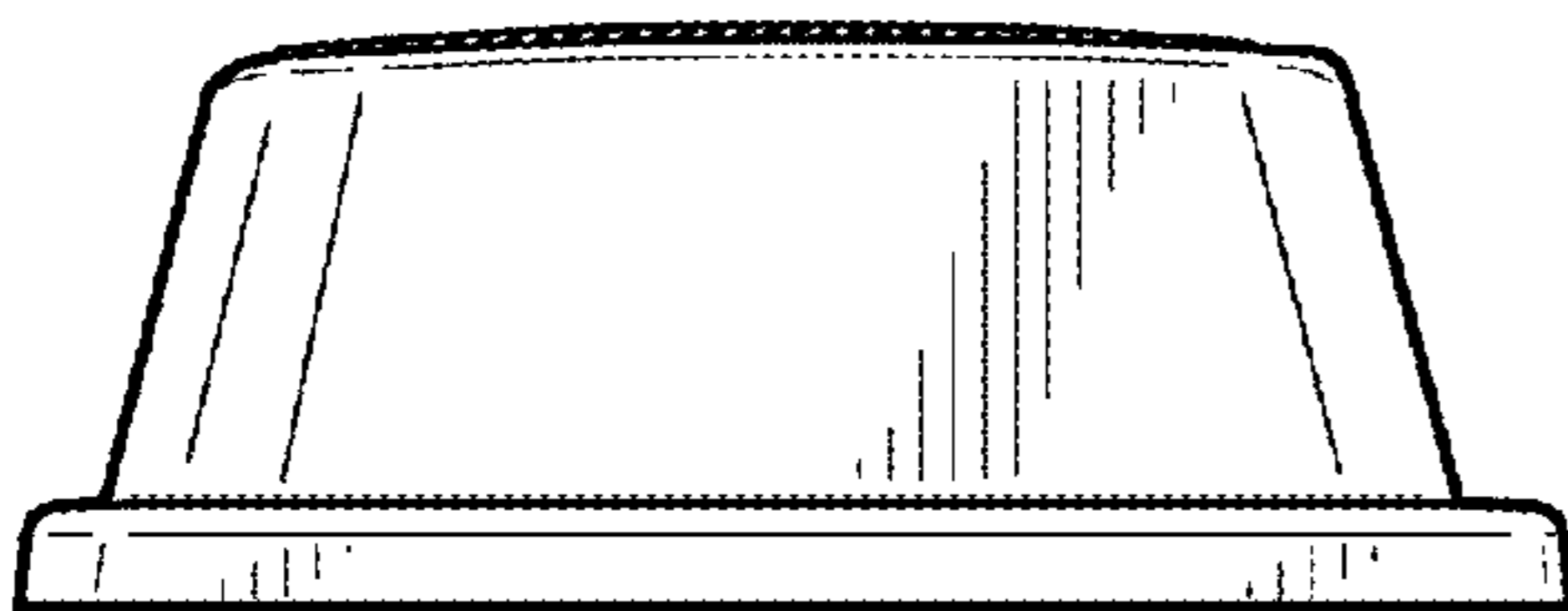
*Fig. 4*



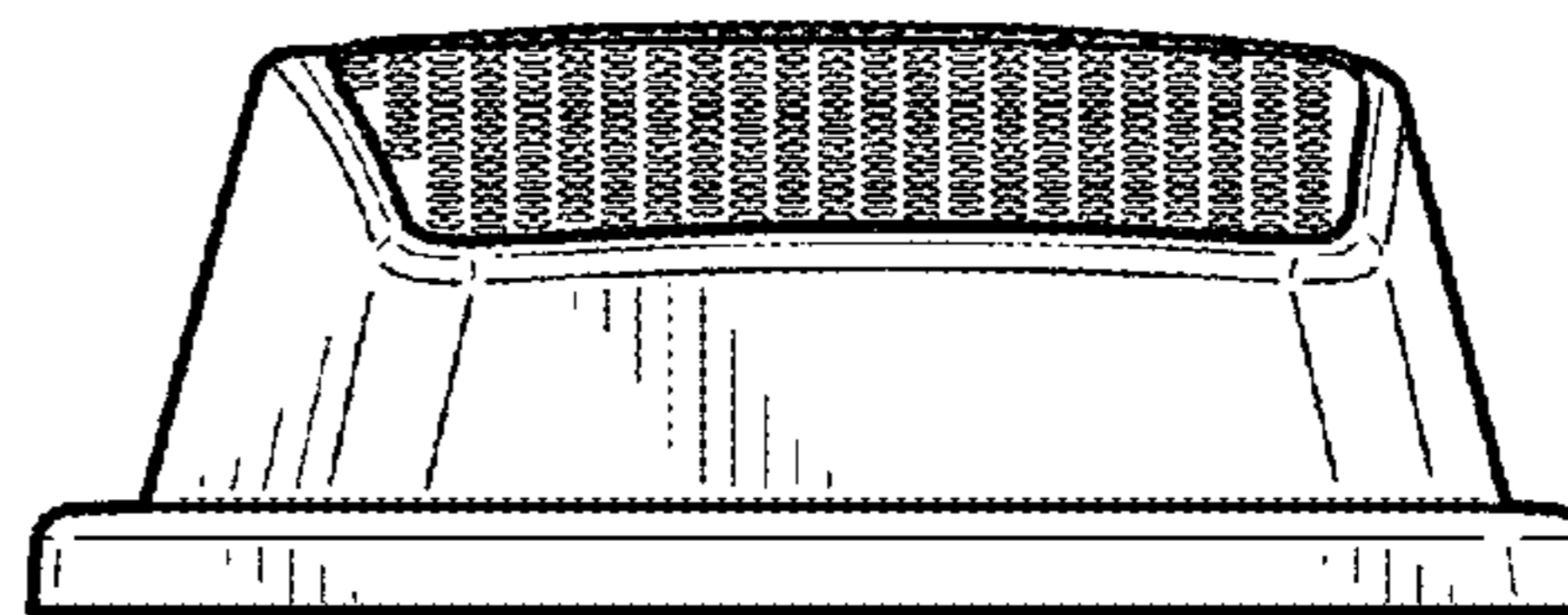
*Fig. 5*



*Fig. 6*



*Fig. 7*



*Fig. 8*