



US00D699707S

(12) **United States Design Patent**
Di Rocco

(10) **Patent No.:** **US D699,707 S**

(45) **Date of Patent:** **** Feb. 18, 2014**

(54) **SPEAKER BOX**

(71) Applicant: **Domenico Di Rocco**, Isernia (IT)

(72) Inventor: **Domenico Di Rocco**, Isernia (IT)

(**) Term: **14 Years**

(21) Appl. No.: **29/440,597**

(22) Filed: **Dec. 21, 2012**

(30) **Foreign Application Priority Data**

Jun. 26, 2012 (EM) 00206393-0004

(51) **LOC (10) Cl.** **14-01**

(52) **U.S. Cl.**
USPC **D14/207**

(58) **Field of Classification Search**
USPC D14/204, 207, 210–216, 172, 209.1;
181/143, 144, 147, 148, 150–153, 157,
181/198, 199; 381/300–303, 306, 332, 333,
381/336, 345, 361–364, 386–388;
D11/160, 162, 606–609, 832
See application file for complete search history.

(56) **References Cited**

U.S. PATENT DOCUMENTS

D67,506 S * 6/1925 Dieterich D14/207
4,764,961 A * 8/1988 Hung 381/308

4,991,688 A * 2/1991 Kery et al. 181/153
5,444,194 A * 8/1995 Reinke 181/150
D370,221 S * 5/1996 Firlow D14/135
6,056,183 A * 5/2000 Tanabe 227/155
6,585,556 B2 * 7/2003 Smirnov 446/175
D528,536 S * 9/2006 Topping D14/207
D530,308 S * 10/2006 Topping D14/207
D618,664 S * 6/2010 Chiu D14/207
D647,146 S * 10/2011 Islava D21/576
D690,285 S * 9/2013 Breines D14/207

* cited by examiner

Primary Examiner — Prabhakar Deshmukh

(74) *Attorney, Agent, or Firm* — Young & Thompson

(57) **CLAIM**

The ornamental design for a speaker box, as shown and described.

DESCRIPTION

FIG. 1 is a front, side, top perspective view of a speaker box showing the new design;
FIG. 2 is a rear, side, bottom perspective view thereof;
FIG. 3 is a side elevation thereof, the other side being a mirror image thereof;
FIG. 4 is a bottom plan view thereof; and,
FIG. 5 is a top plan view thereof.

1 Claim, 5 Drawing Sheets

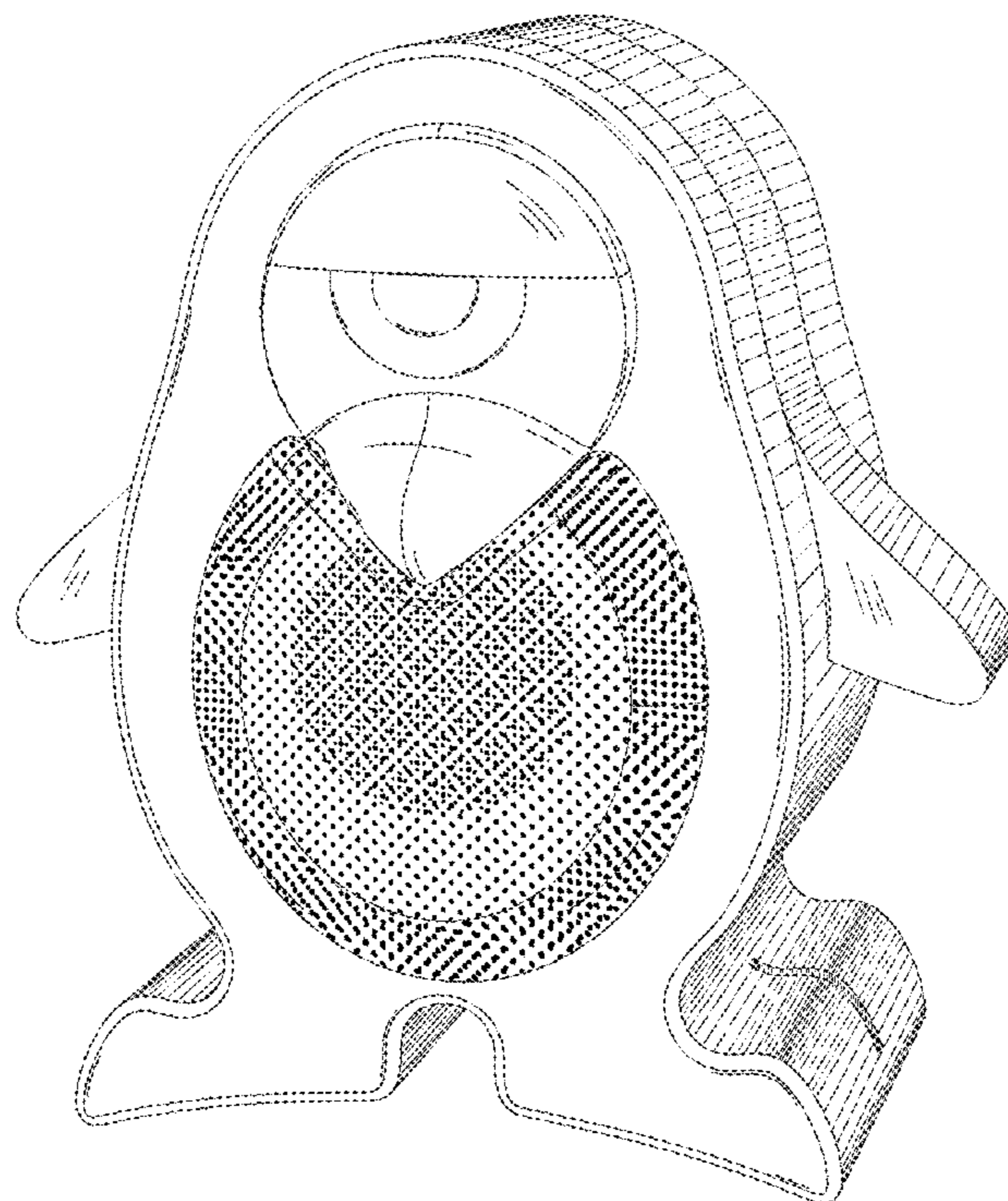

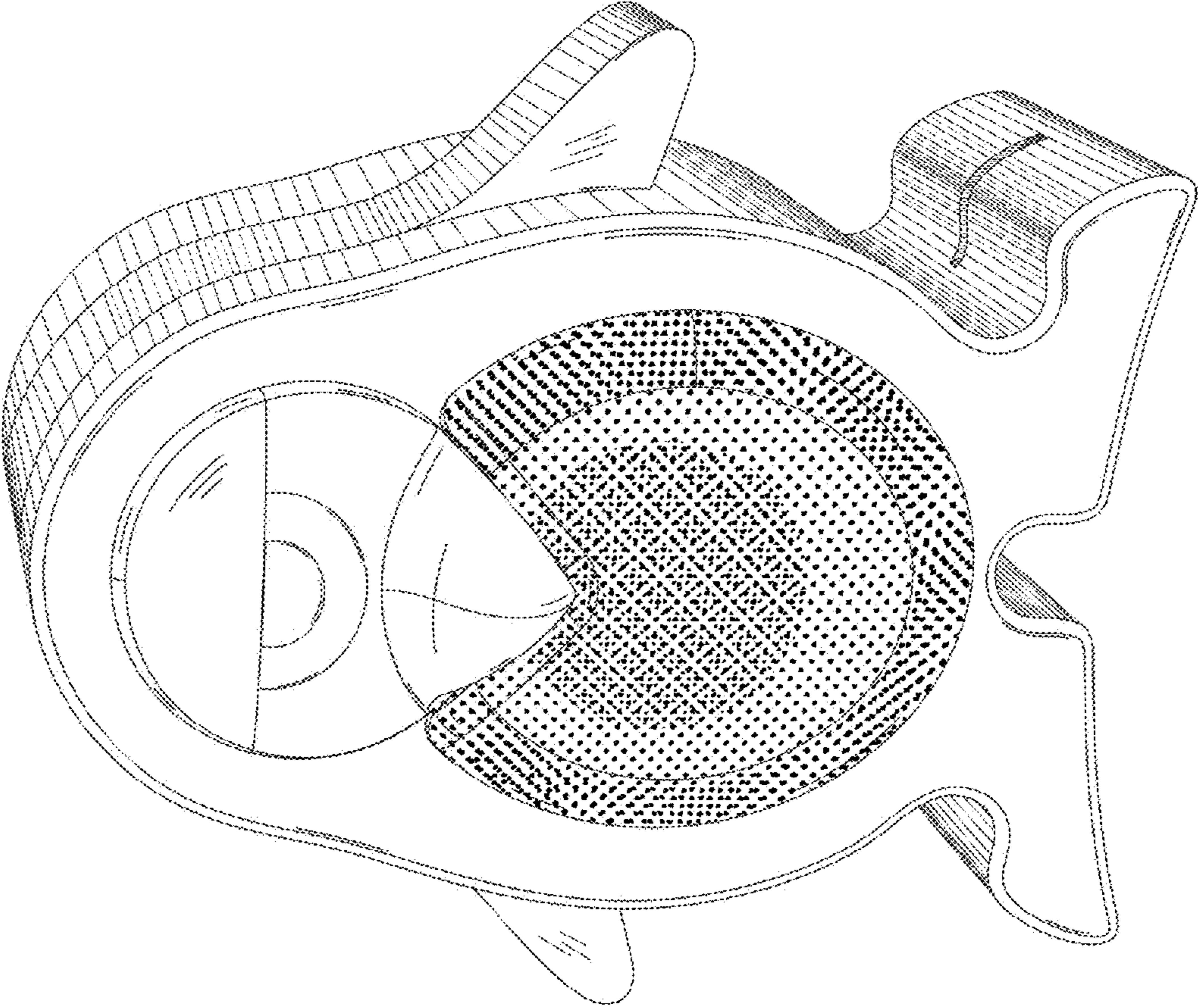

Fig. 1

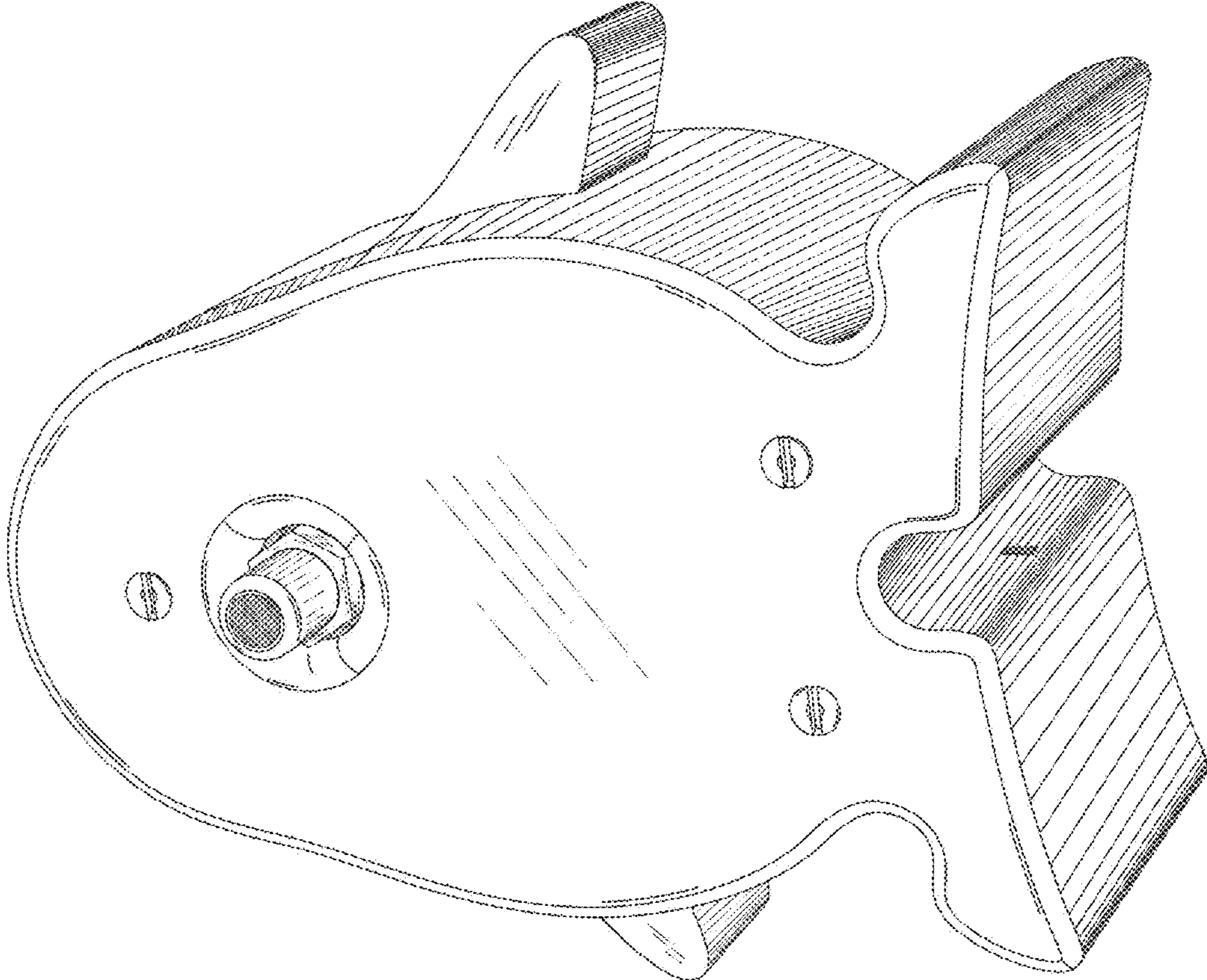

Fig. 2

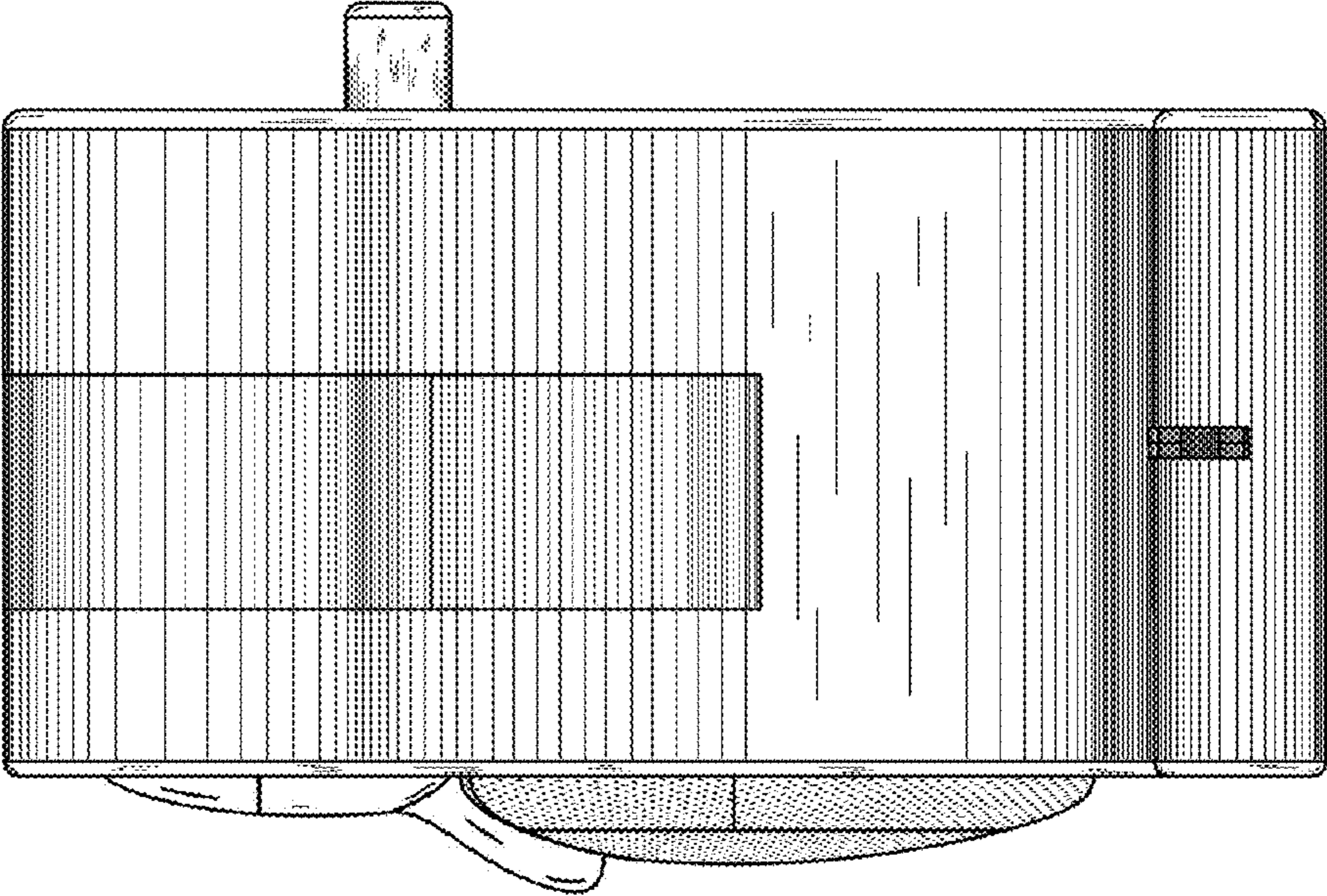

Fig. 3

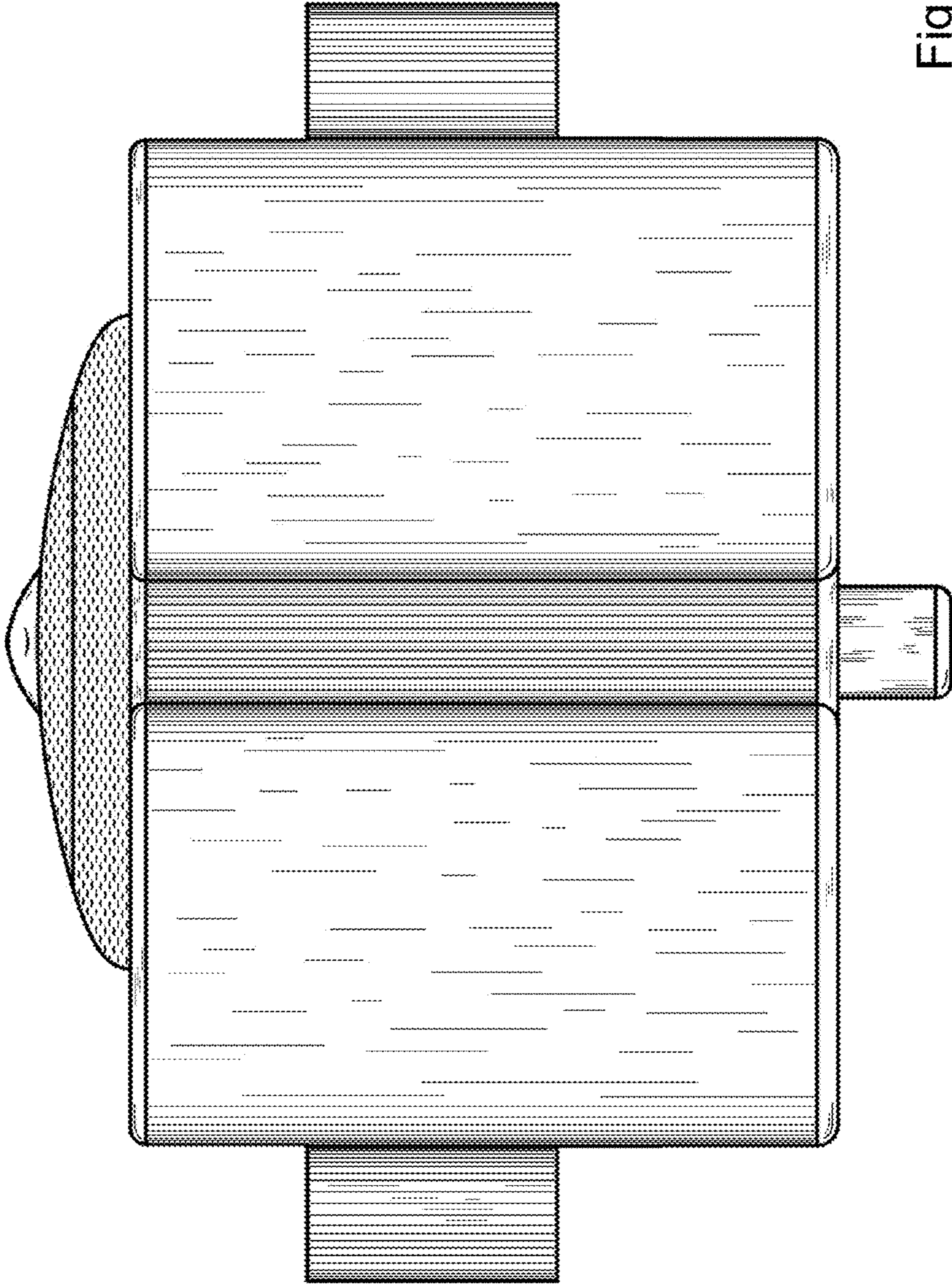

Fig. 4

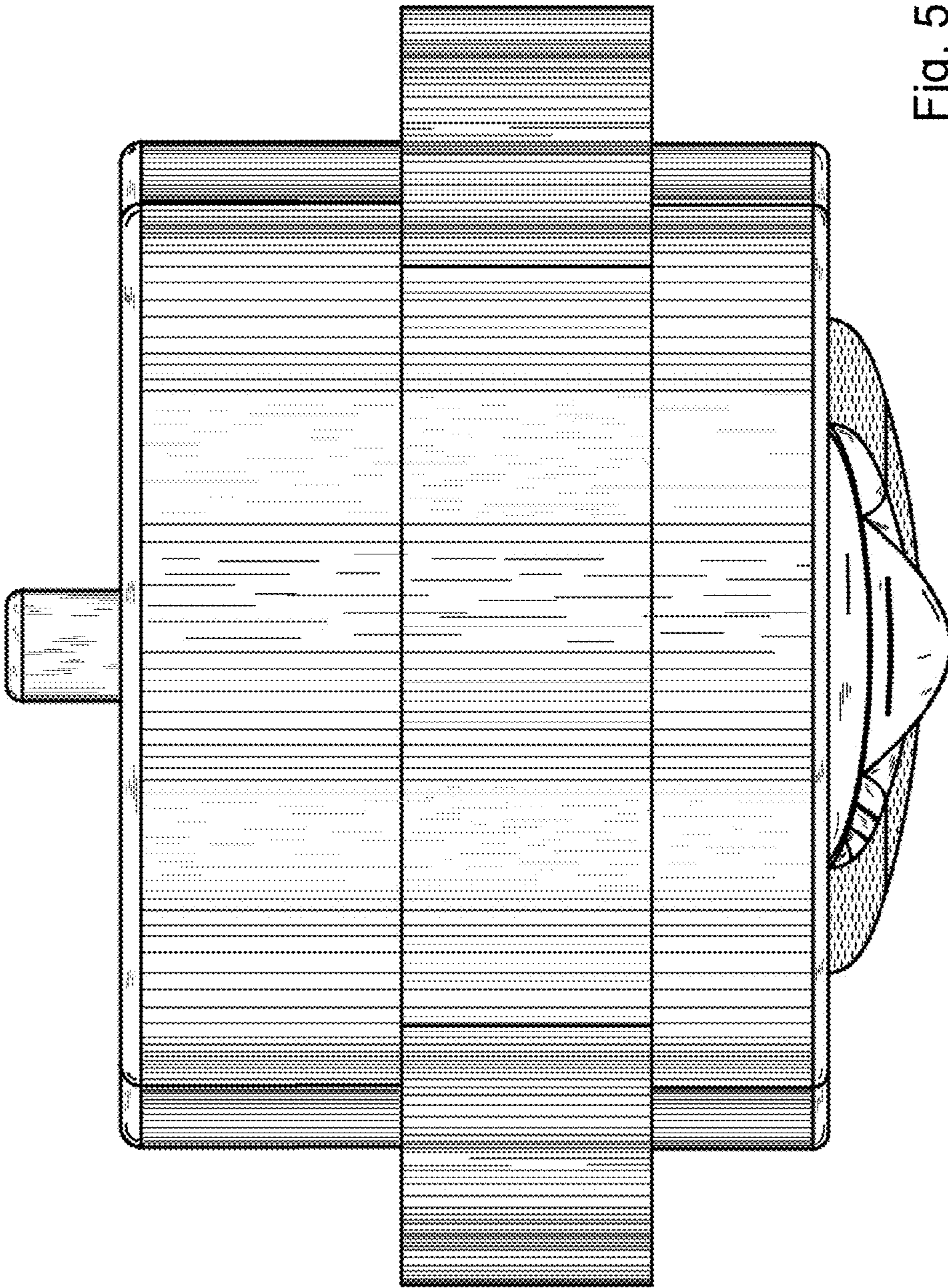

Fig. 5