



US00D699637S

(12) **United States Design Patent**
Noble

(10) **Patent No.:** **US D699,637 S**
(45) **Date of Patent:** **** Feb. 18, 2014**

(54) **SHEAR SPRING FOR A SUSPENSION**

FOREIGN PATENT DOCUMENTS

(75) Inventor: **Shawn D. Noble**, Naperville, IL (US)

CN 301364969 10/2010
DE 3524916 1/1987

(73) Assignee: **Hendrickson USA, L.L.C.**, Itasca, IL (US)

(Continued)

(**) Term: **14 Years**

OTHER PUBLICATIONS

Hendrickson, Parts List HN 402/462, Sep. 1997.

(21) Appl. No.: **29/426,563**

(Continued)

(22) Filed: **Jul. 6, 2012**

Primary Examiner — Michael A Pratt

(51) **LOC (10) Cl.** **12-16**

(74) *Attorney, Agent, or Firm* — McDonnell Boehnen Hulbert & Berghoff LLP

(52) **U.S. Cl.**

(57) **CLAIM**

USPC **D12/160**

The ornamental design for a shear spring for a suspension, as shown and described.

(58) **Field of Classification Search**

DESCRIPTION

USPC D12/160; 280/11.225, 86.752, 104, 280/124.145–124.147, 124.155, 676, 677, 280/681, 682, 687; 267/64.15, 136, 195, 267/217; 188/274, 281, 286, 297–298, 188/315–316; 464/173; D21/763; 293/134

FIG. 1 is a bottom right front corner perspective view of a shear spring for a suspension having the inventive design; FIG. 2 is a bottom plan view of the shear spring for a suspension shown in FIG. 1; FIG. 3 is a top plan view of the shear spring for a suspension shown in FIG. 1; FIG. 4 is a left side elevation view of the shear spring for a suspension shown in FIG. 1; FIG. 5 is a right side elevation view of the shear spring for a suspension shown in FIG. 1; FIG. 6 is a front elevation view of the shear spring for a suspension shown in FIG. 1; FIG. 7 is a rear elevation view of the shear spring for a suspension shown in FIG. 1; FIG. 8 is a bottom right rear corner perspective view of the shear spring for a suspension shown in FIG. 1; FIG. 9 is a top left front corner perspective view of the shear spring for a suspension shown in FIG. 1; and, FIG. 10 is a top left rear corner perspective view of the shear spring for a suspension shown in FIG. 1.

See application file for complete search history.

(56) **References Cited**

U.S. PATENT DOCUMENTS

7,706 A	10/1850	Ray
2,111,475 A	3/1938	Kegresse
2,197,727 A	4/1940	Ledwinka
2,245,296 A	6/1941	Piron
2,284,484 A	5/1942	Eksergian
2,286,563 A	6/1942	Mussey
2,323,919 A	7/1943	Knox
2,437,158 A	3/1948	Heiney
2,655,005 A	10/1953	Kinneman
2,663,570 A	12/1953	Hickman
2,689,136 A	9/1954	Hendrickson
2,704,664 A	3/1955	Hickman
2,706,113 A	4/1955	Hickman

(Continued)

1 Claim, 5 Drawing Sheets

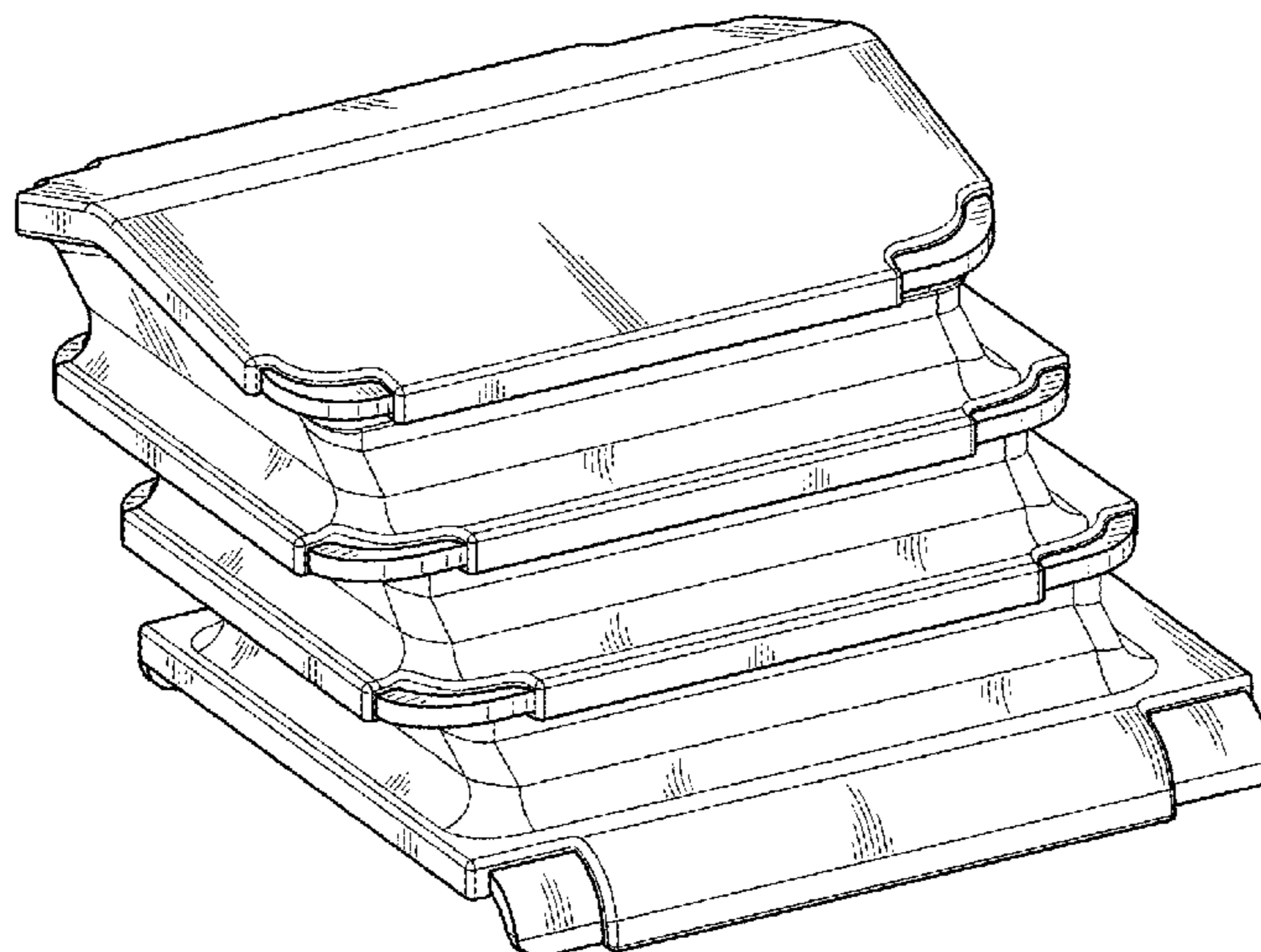

(56)

References Cited

U.S. PATENT DOCUMENTS

2,739,821 A	3/1956	Hickman	4,488,495 A	12/1984	Dean, II
2,750,200 A	6/1956	Scheel	4,504,080 A	3/1985	Van Denberg
2,758,832 A	8/1956	Hickman	4,527,365 A	7/1985	Yoshizawa et al.
2,775,353 A	12/1956	Tillou	4,548,150 A	10/1985	Drewett
2,798,735 A	7/1957	Compton	4,585,086 A	4/1986	Hiramatsu
2,802,662 A	8/1957	Hirst	4,589,347 A	5/1986	Colford et al.
2,872,207 A	2/1959	Hirst	4,705,294 A	11/1987	Raidel
2,880,885 A	4/1959	Willison	4,733,855 A	3/1988	Balczun et al.
2,940,771 A	6/1960	Hendrickson	4,753,456 A	6/1988	Booher
2,980,439 A	4/1961	Miller	4,781,365 A	11/1988	Harrison
2,981,208 A	4/1961	Sinclair	4,793,597 A	12/1988	Smith
2,995,383 A	8/1961	Barker	4,968,010 A	11/1990	Odobasic
3,011,776 A	12/1961	Reed	4,995,636 A	2/1991	Hall et al.
3,017,195 A	1/1962	Hickman	5,114,178 A	5/1992	Baxter
3,030,098 A	4/1962	Roubal	5,118,086 A	6/1992	Stevenson et al.
3,037,764 A	6/1962	Paulsen	5,150,657 A	9/1992	Bourgeot
3,045,998 A	7/1962	Hirst	5,150,918 A	9/1992	Heitzmann
3,047,163 A	7/1962	Johnson et al.	5,237,933 A	8/1993	Bucksbee
3,071,422 A	1/1963	Hinks	5,271,678 A	12/1993	Bourgeot
3,121,560 A	2/1964	Reed	5,364,086 A	11/1994	Paton
3,134,585 A	5/1964	Trask	5,413,320 A	5/1995	Herbst
3,241,856 A	3/1966	Raidel	5,447,324 A	9/1995	Raidel, Sr.
3,276,395 A	10/1966	Heintzel	5,465,997 A	11/1995	Heitzmann
3,279,779 A	10/1966	Thomas et al.	5,482,406 A	1/1996	Arlt, III
3,279,820 A	10/1966	Hickman	5,615,786 A	4/1997	Hoyon et al.
3,297,339 A	1/1967	Hendrickson	5,676,356 A	10/1997	Ekonen et al.
3,301,573 A	1/1967	Hickman	5,810,337 A	9/1998	McLaughlin
3,305,227 A	2/1967	Henley	5,868,384 A	2/1999	Anderson
3,315,951 A	4/1967	Boschi et al.	5,887,881 A	3/1999	Hatch
3,368,806 A	2/1968	Szonn	5,899,470 A	5/1999	Heitzmann
3,471,165 A	10/1969	Raidel	5,938,221 A	8/1999	Wilson
3,482,852 A	12/1969	Hickman	5,947,458 A	9/1999	Rhodes et al.
3,539,170 A	11/1970	Hamel	5,957,441 A	9/1999	Tews
3,563,525 A	2/1971	Narabu	6,045,328 A	4/2000	Jones
3,572,745 A	3/1971	Willetts	6,178,894 B1	1/2001	Leingang
3,575,403 A	4/1971	Hamel et al.	6,193,266 B1	2/2001	Cortez et al.
3,606,295 A	9/1971	Appleton	6,206,407 B1	3/2001	Fuchs et al.
3,618,533 A	11/1971	Hirst	6,264,231 B1	7/2001	Scully
3,618,971 A	11/1971	Wragg	6,276,674 B1	8/2001	Randell
3,625,501 A	12/1971	Hein et al.	6,328,294 B1	12/2001	Palinkas
3,626,465 A	12/1971	Hirst	6,478,321 B1	11/2002	Heitzmann
3,687,477 A	8/1972	Miller	6,516,914 B1	2/2003	Andersen et al.
3,695,737 A	10/1972	Alexander et al.	6,572,087 B2	6/2003	Schleinitz et al.
3,699,897 A	10/1972	Sherrick	6,585,286 B2	7/2003	Adema et al.
3,712,246 A	1/1973	Lich	6,588,820 B2	7/2003	Rice
3,731,913 A	5/1973	Hirst	6,659,438 B2	12/2003	Michael et al.
3,797,851 A	3/1974	Hirst	6,817,301 B1	11/2004	Bullock
3,811,700 A	5/1974	Moore	6,877,623 B2	4/2005	Salis
3,817,551 A	6/1974	Moore	6,916,037 B2	7/2005	Baxter et al.
3,830,483 A	8/1974	Gaydecki	6,951,260 B1	10/2005	Isley
3,831,923 A	8/1974	Meldrum	7,077,411 B2	7/2006	Peters et al.
3,857,556 A	12/1974	Wing	7,185,903 B2	3/2007	Dove
3,936,073 A	2/1976	Hickman et al.	7,229,088 B2	6/2007	Dudding et al.
3,952,669 A	4/1976	Mauzin et al.	7,234,723 B2	6/2007	Sellers
3,955,808 A	5/1976	Jorn et al.	7,303,200 B2	12/2007	Ramsey
3,984,125 A	10/1976	Paton et al.	7,387,074 B2	6/2008	Myers
3,997,151 A	12/1976	Leingang	D603,303 S	11/2009	Noble et al.
3,999,497 A	12/1976	Hamel	D605,984 S	12/2009	Noble et al.
4,082,316 A	4/1978	Raidel	D610,952 S	3/2010	Noble et al.
4,108,470 A	8/1978	Vinton	D624,465 S	9/2010	Noble et al.
4,111,131 A	9/1978	Bullock	7,832,508 B2	11/2010	Isley
4,111,406 A	9/1978	Zanow	7,845,288 B2	12/2010	Forbes et al.
4,132,433 A	1/1979	Willetts	D633,011 S	2/2011	Noble et al.
4,134,343 A	1/1979	Jackson	7,926,836 B2	4/2011	Noble et al.
4,144,978 A	3/1979	Drake	8,052,166 B2	11/2011	Noble et al.
4,162,799 A	7/1979	Willetts	8,070,143 B2	12/2011	Wietharn
4,182,338 A	1/1980	Stanulis	8,152,195 B2	4/2012	Noble et al.
4,193,612 A	3/1980	Masser	8,210,507 B2	7/2012	Mitsch
4,213,633 A	7/1980	Moore et al.	8,262,112 B1	9/2012	Noble et al.
4,258,629 A	3/1981	Jackson et al.	8,302,988 B2	11/2012	Noble et al.
4,278,271 A	7/1981	Raidel	D672,286 S	12/2012	Noble et al.
4,358,096 A	11/1982	Paton et al.	2002/0163165 A1	11/2002	Adema et al.
4,371,189 A	2/1983	Raidel	2004/0262877 A1	12/2004	Sellers
4,420,171 A	12/1983	Raidel	2006/0071441 A1	4/2006	Mathis
4,486,029 A	12/1984	Raidel	2007/0262547 A1	11/2007	Warinner
			2008/0018070 A1	1/2008	Gottschalk
			2008/0030006 A1	2/2008	Sellers
			2008/0122146 A1	5/2008	Herntier et al.
			2008/0290572 A1	11/2008	Desprez et al.

(56)

References Cited

U.S. PATENT DOCUMENTS

2009/0008846	A1	1/2009	Yamakawa et al.	
2009/0218740	A1*	9/2009	Gedenk	267/294
2009/0224504	A1	9/2009	Noble et al.	
2009/0224513	A1	9/2009	Noble et al.	
2010/0044992	A1	2/2010	Noble et al.	
2010/0072733	A1	3/2010	Levi	
2010/0270719	A1	10/2010	Ranum et al.	
2011/0031662	A1*	2/2011	Toyama	267/121
2011/0057407	A1	3/2011	Noble et al.	
2012/0001373	A1	1/2012	McLaughlin	
2012/0325107	A1	12/2012	Wicks et al.	
2013/0019774	A1	1/2013	Ahuja et al.	
2013/0033018	A1	2/2013	Kiselis et al.	
2013/0069333	A1	3/2013	Pizzeta	
2013/0162007	A1	6/2013	Oriet	

FOREIGN PATENT DOCUMENTS

DE	973418	3/1993
DE	4128488	3/1993
DE	4204783	8/1993
EP	0419057	3/1991
FR	2270487	12/1975
FR	2342193	9/1977
GB	997305	7/1965
GB	2069424	8/1981
GB	2128942	5/1984
GB	2252276	8/1992
JP	64-035134	2/1989
JP	05338552	12/1993
WO	92/15800	9/1992
WO	0242097	5/2002
WO	2010068319	6/2010

OTHER PUBLICATIONS

Hendrickson, Parts List HN Series, Dec. 2004.
 Hendrickson Truck Suspension Systems, A Boler Company, Technical Publication RS-340 thru 520, Subject: Springing: Frame Hangers, Load Cushions and Saddle Assembly, Jul. 1993.
 Hendrickson Truck Suspension Systems, A Boler Company, Technical Publication HN Series Truck & Trailer Suspension No. 17730-198, Mar. 1993.
 Hendrickson, Technical Procedure HN/HNT-400/460 Truck & Trailer Suspension in Production Nov. 1988-Sep. 1996, Apr. 1998.
 Hendrickson Truck Suspension Systems, A Boler Company, Technical Publication HN 402 Series, Subject: Service Instructions, Aug. 1996.
 Hendrickson Truck Suspension Systems, A Boler Company, Technical Publication HN 402/462 Series, Subject: Service Instructions, Aug. 1998.
 Hendrickson, Technical Procedure Haulmaax, Subject: Service Instructions, May 2002.
 Hendrickson, Technical Procedure Haulmaax, Subject: Service Instructions, Jun. 2007.
 Hendrickson, Technical Procedure Haulmaax, Subject: Pre-delivery Inspection and Preventive Maintenance, Apr. 2006.
 Hendrickson, Technical Procedure Haulmaax, Subject: Service Instructions, Dec. 2007.
 Hendrickson, Technical Procedure R/RS/RT Heavy Duty, Subject: 650K/850K/1000K Pound Capacity Beam End Connection Tightening Torque Procedure, Jul. 2006.
 Hendrickson, RS Series Rubber Load Cushion, Feb. 2000.
 MOR/ryde, The MOR/ryde Steer and Drive Axle Suspension Systems, Mar. 7, 2008.
 MOR/ryde, Company Profile, downloaded from the World Wide Web at <http://www.morrydede.com/php/about/profile/php> on Feb. 28, 2008.
 MOR/ryde, T/A Modular Rubber Suspension System, Service Manual, Mar. 5, 2003.

MOR/ryde, Tandem Axle Rubber Suspension Sytem, Service Manual, Suspension Codes: T01-01 and L01-01, Mar. 5, 2003.
 MOR/ryde, RL Rubber Leaf Suspension System, Owner's Manual, Mar. 12, 2003.
 MOR/ryde, Commercial Trailer Suspension, Jun. 1973.
 MOR/ryde, School Bus Suspension, Aug. 1973.
 MOR/ryde, a rubber spring . . . heart of the Mor/ryde system, Aug. 1973.
 Jorn, Technology in Rubber—Metal, Sep. 29, 2008.
 Hendrickson, Parts List RS Series, Apr. 2008.
 Hendrickson, Technical Procedure, R/RS Heavy Duty, Subject: 85K/100K/120K lbs Capacity Tightening Torgue for Torque Rod and Saddle Assembly Fasteners, Oct. 2008.
 Noble et al., U.S. Appl. No. 29/396,892, filed Jul. 8, 2011.
 Noble et al., U.S. Appl. No. 29/396,893, filed Jul. 8, 2011.
 Hendrickson USA, L.L.C., Technical Procedure HUV 270t Heavy-duty Rubber Suspension, Subject: Service Instructions, Lit. No. 17730-269, Revision C, Feb. 2010.
 Hendrickson, Haulmaxx Heavy-Duty Suspension, Jan. 2009.
 Hendrickson, HN FR Series, HN FR Suspension 42-58K Fire/Rescue, Feb. 2009.
 Hendrickson Technical Brochure for “Bus Air Ride Suspensions” H621 Oct. 1998.
 Hendrickson Technical Brochure for “Non-Steerable Suspension Systems” H621 Dec. 2003.
 Hendrickson USA, L.L.C., HUV, Lightweight Design, Premium Ride and Performance, Outstanding Durability, Nov. 2010.
 Hendrickson USA, L.L.C., HUV Heavy-duty Rubber Suspension, Dec. 2009.
 Hendrickson, A Boler Company, Hendrickson Frame Hanger Selection Guide, May 1990.
 Hendrickson, A Boler Company, Hendrickson RS Series, Single Axle Suspension, Sep. 1995.
 Hendrickson, RS Series Rubber Load Cushion, Only Hendrickson makes choosing a heavy-duty suspension this easy, Jun. 1993.
 Hendrickson, A Boler Company, HN Series Technical Sales Publication, Jun. 1997.
 Hendrickson Suspension, RS Series rubber load cushion, Jul. 1991.
 Hendrickson Mfg., Tandem Division, Wide spread equalizing beams, sales bulletin, May 1981.
 Hendrickson Mfg. Co., Tandem Division, Hendrickson Tandem Suspensions for GMC Trucks, Aug. 1979.
 Hendrickson, The Boler Company, RS Frame Hanger, Dec. 1997.
 Hendrickson, A Boler Company, RS Series Rubber Load Cushion Suspensions, Mar. 1996.
 Hendrickson, A Boler Company, RS Series Rubber Load Cushion Suspensions, Jul. 1996.
 Hendrickson, A Boler Company, RS Series Rubber Load Cushion, Mar. 1998.
 Hendrickson Suspension, HN Series Premium Rubber, Hendrickson introduces a completely new concept in Walking Beam Suspension, Jun. 1993.
 Hendrickson Suspension, A Boler Company, Hendrickson HNT Series, Feb. 1992.
 Hendrickson Suspension, Sales Engineering Update, Mar. 1993.
 Hendrickson Truck Suspension Systems, A Boler Company, RS Series Rubber Load Cushion, Dec. 1996.
 Hendrickson Truck Suspension Systems, A Boler Company, RS Series Rubber Load Cushion, Apr. 1998.
 Hendrickson Truck Suspension Systems, A Boler Company, HN Series VariRate Spring System, May 1997.
 Hendrickson Truck Suspension Systems, A Boler Company, HN Series VariRate Spring System, Nov. 1997.
 Hendrickson Truck Suspension Systems, A Boler Company, HN Series VariRate Spring System, Sep. 1998.
 Hendrickson Truck Suspension Systems, A Boler Company, HN Series VariRate Spring System, Jul. 1999.
 Hendrickson, HN Series VariRate Spring System, Nov. 2000.
 Hendrickson, HN Series VariRate Spring System, Nov. 2005.
 Hendrickson Truck Suspension Systems, A Boler Company, HN 402, Feb. 1996.
 Hendrickson Truck Suspension Systems, A Boler Company, R Series Solid Mount, Jul. 1999.

(56)

References Cited

OTHER PUBLICATIONS

Hendrickson Truck Suspension Systems, A Boler Company, RS Series Rubber Load Cushion, Jun. 1999.
Hendrickson, Haulmaax Heavy Duty Suspension, Oct. 2001.
Hendrickson, Haulmaax Heavy Duty Suspension, Dec. 2003.
Hendrickson, Haulmaax Heavy Duty Suspension, Mar. 2005.
Hendrickson, Haulmaax Heavy Duty Suspension, Jan. 2007.
Hendrickson, Haulmaax Heavy Duty Suspension, Mar. 2008.
Hendrickson, Assembly Instructions Haulmaax, Subject: Kit Nos. 64178-003 & 004, Feb. 2003.
Hendrickson, Assembly Instructions Haulmaax, Subject: Tie-bar Bolster Spring Kit Nos. 64179-037, Jun. 2006.
Hendrickson, Assembly Instructions Haulmaax, Subject: Outboard Frame Bracket for Paccar Vehicles Built after May 1, 2005 through Aug. 31, 2006, Oct. 2006.
Hendrickson, Assembly Instructions Haulmaax Saddle Assembly, Subject: Service Kit No. 57974-048, Dec. 2008.
Hendrickson, Technical Bulletin HN 402/462/522, Subject: Auxiliary Spring Shim Design, Oct. 2000.
Hendrickson, Technical Bulletin HN 402/462/522, Subject: Auxiliary Spring Shim Design, Dec. 2000.
Hendrickson, Technical Bulletin HN 402/462/522, Subject: Auxiliary Spring Shim Design, Jun. 2006.

Hendrickson, Technical Bulletin Haulmaax Series, Subject: Mandatory Shock Applications, Nov. 2004.
Hendrickson, Technical Bulletin R, RS, RT/RTE 46K Capacity, Subject: 46K Heavy-Duty Beam Option, Dec. 2004.
Hendrickson, Technical Bulletin Haulmaax, Subject: 54" Equalizing Beam Assembly, Oct. 2005.
Hendrickson, Technical Bulletin Haulmaax 460, Subject: Bolster Spring Assembly with Tie-bar, Jun. 2006.
Hendrickson Truck Suspension Systems, A Boler Company, Sales engineering update, Subject: HN-402/462 Auxiliary Spring Assembly, Aug. 1998.
Hendrickson Truck Suspension Systems, A Boler Company, Sales engineering update, Subject: Model Designation and Discontinuation, Aug. 1999.
Hendrickson Truck Suspension Systems, A Boler Company, Sales engineering update, Subject: Equalizer Beam, Aug. 1999.
Hendrickson, Parts List RS Series, Nov. 2004.
Hendrickson, Parts List Haulmaax, May 2002.
Hendrickson, Parts List Haulmaax, Jul. 2003.
Hendrickson, Parts List Haulmaax, Jul. 2006.
Hendrickson, Parts List Haulmaax, Dec. 2007.
Hendrickson, Parts List RS 400/460/480/520 Jan. 1998.
U.S. Appl. No. 29/396,892, filed Jul. 8, 2011, 11 pages.
Kenworth Truck Company, Haulmaxx, May 14, 2009.

* cited by examiner

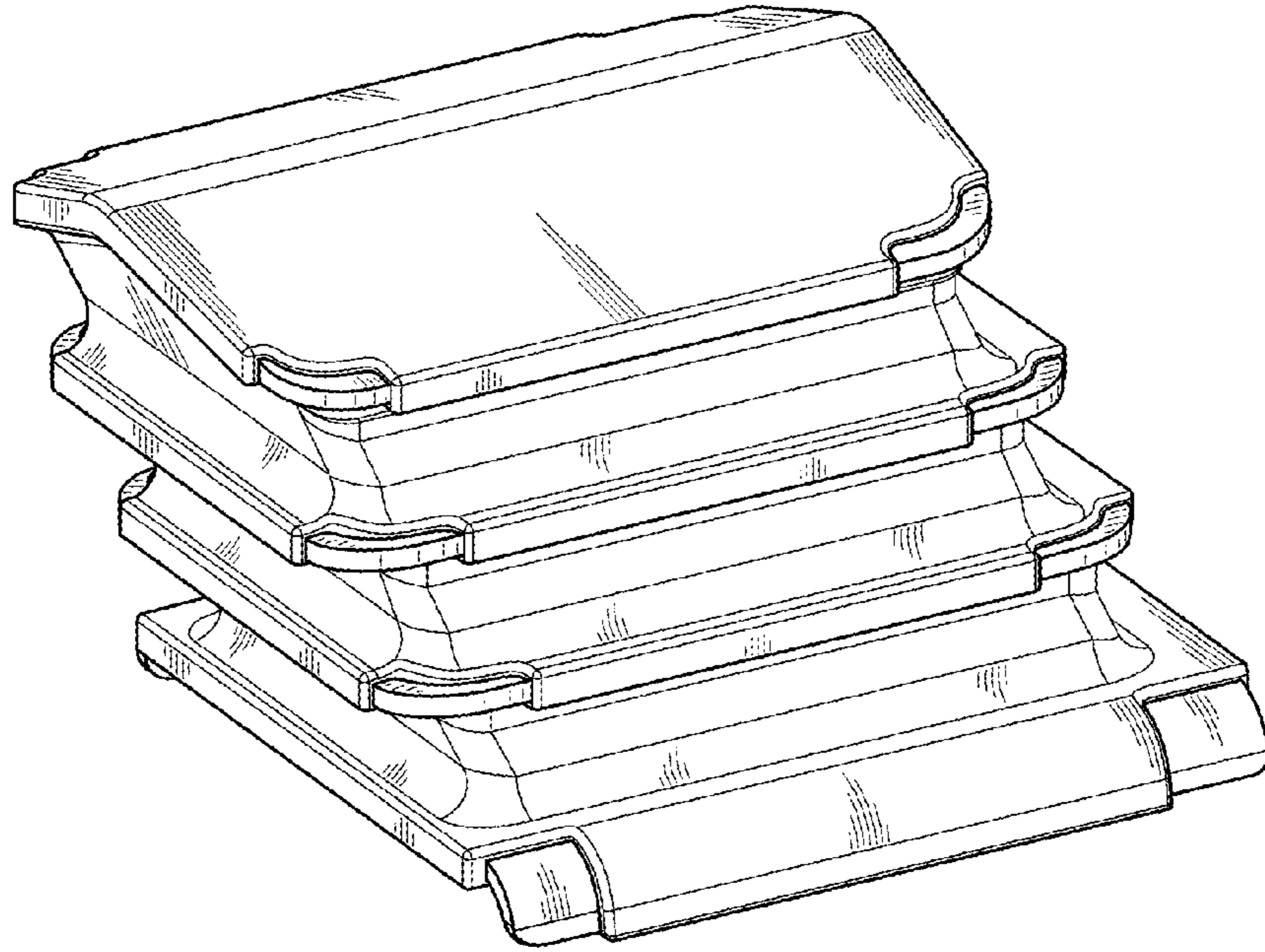

FIG. 1

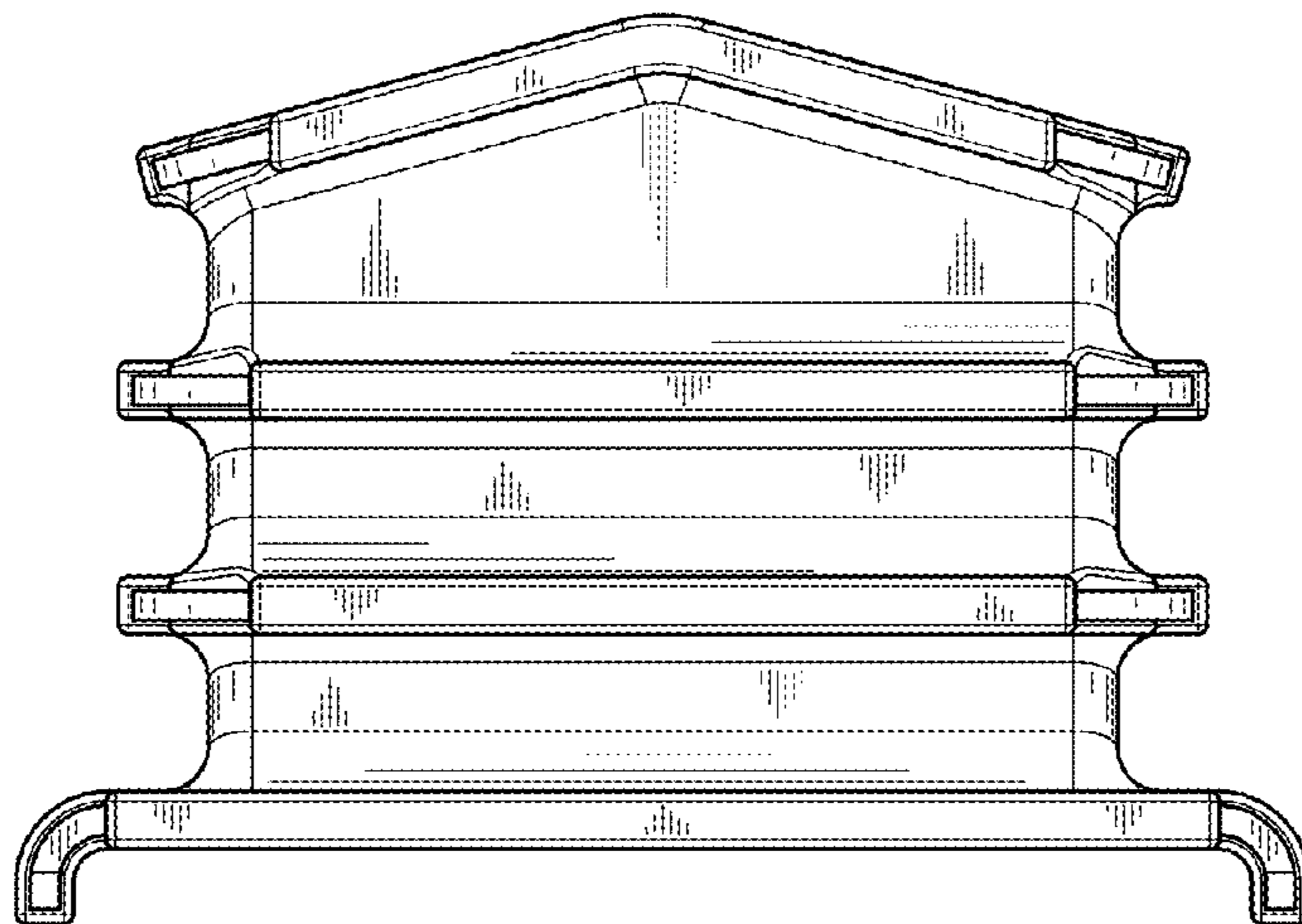

FIG. 2

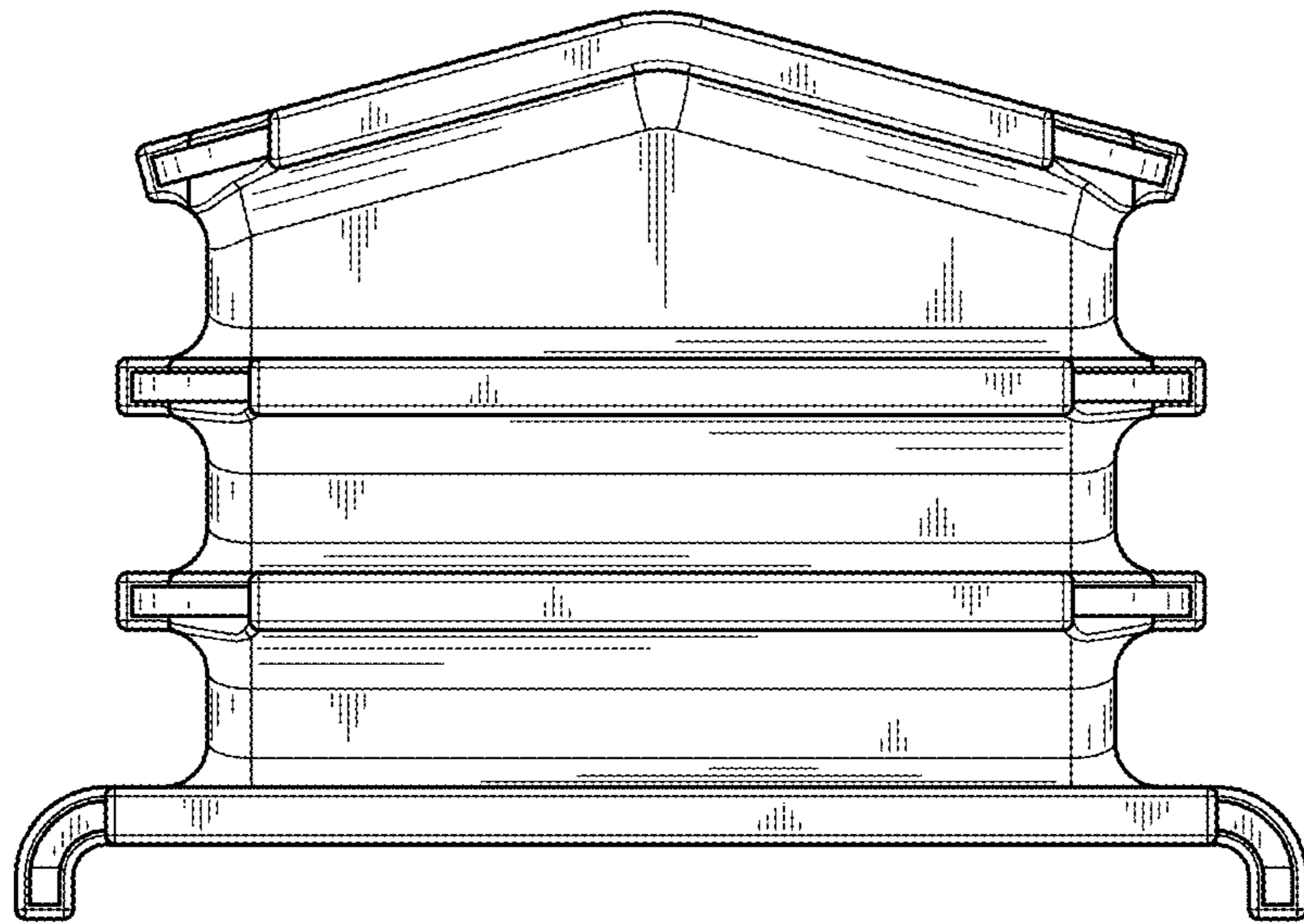

FIG. 3

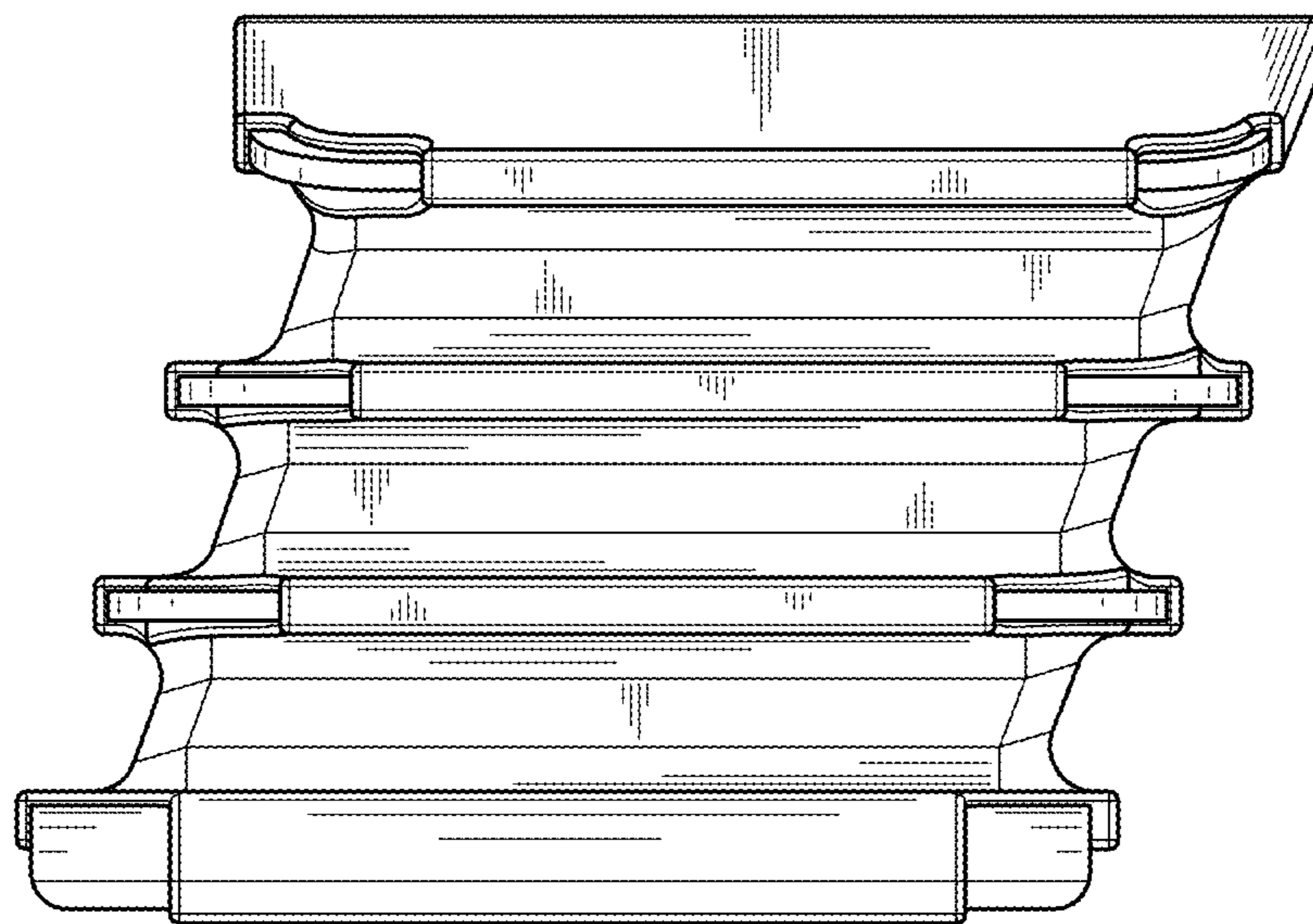

FIG. 4

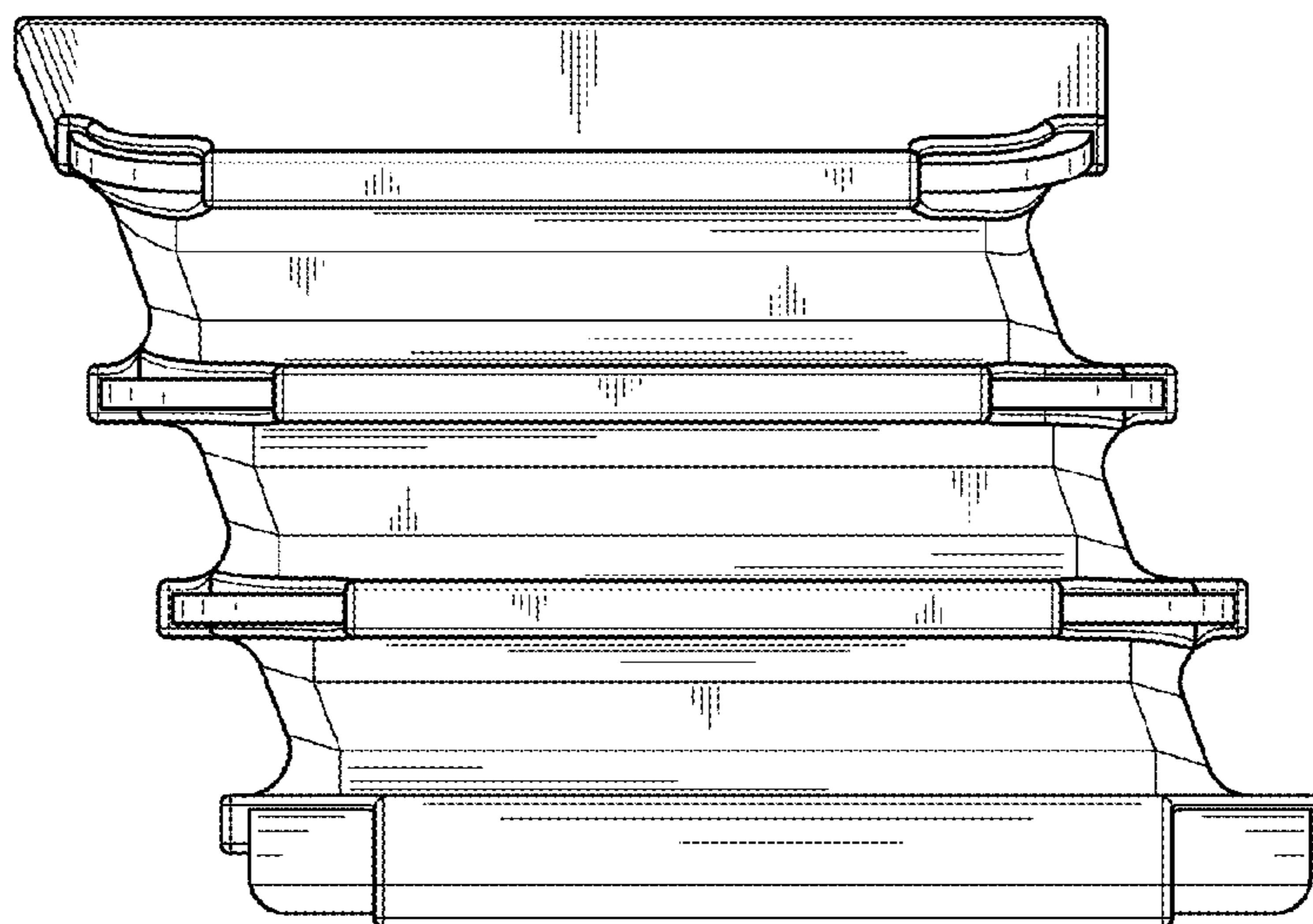

FIG. 5

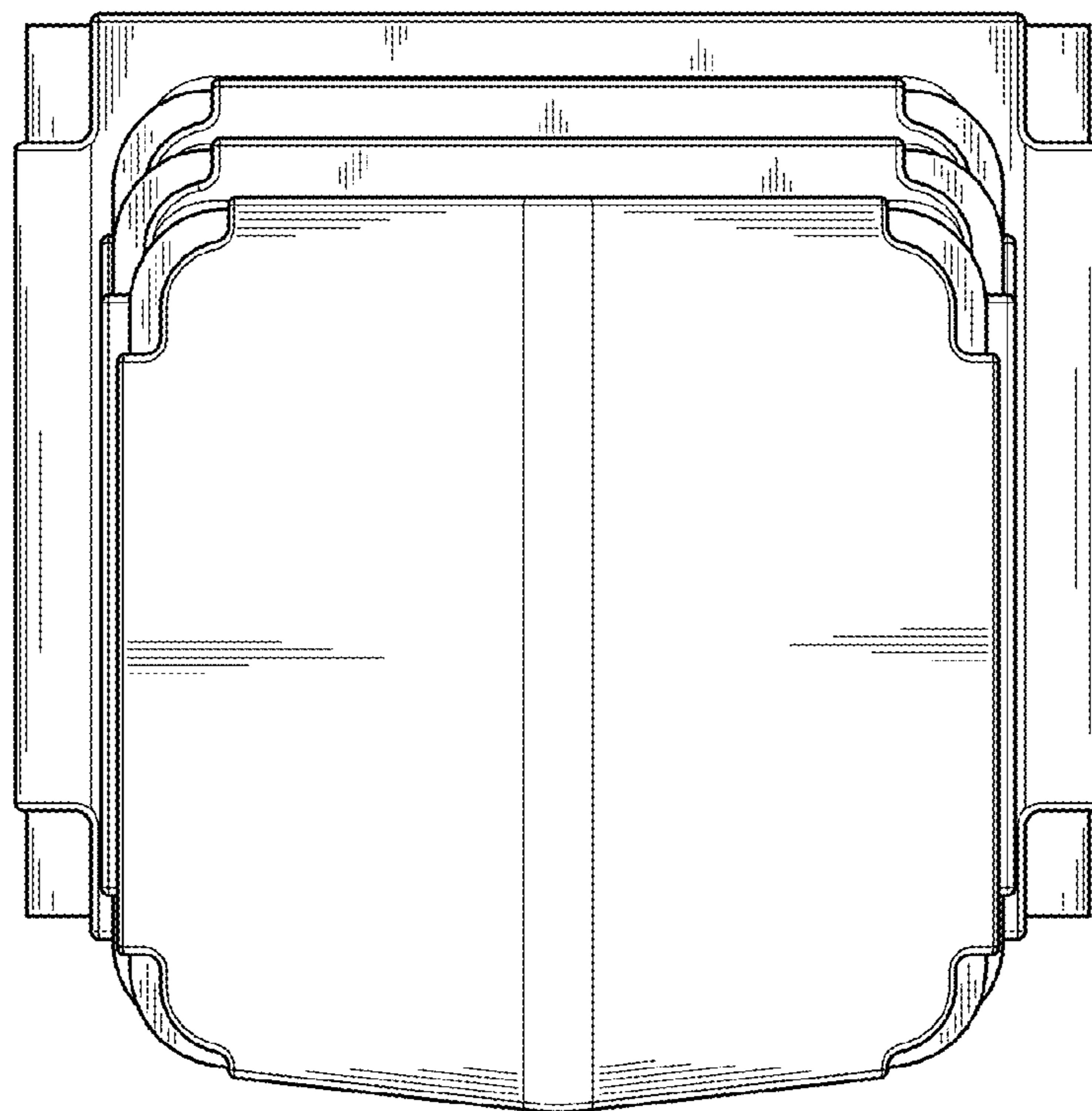

FIG. 6

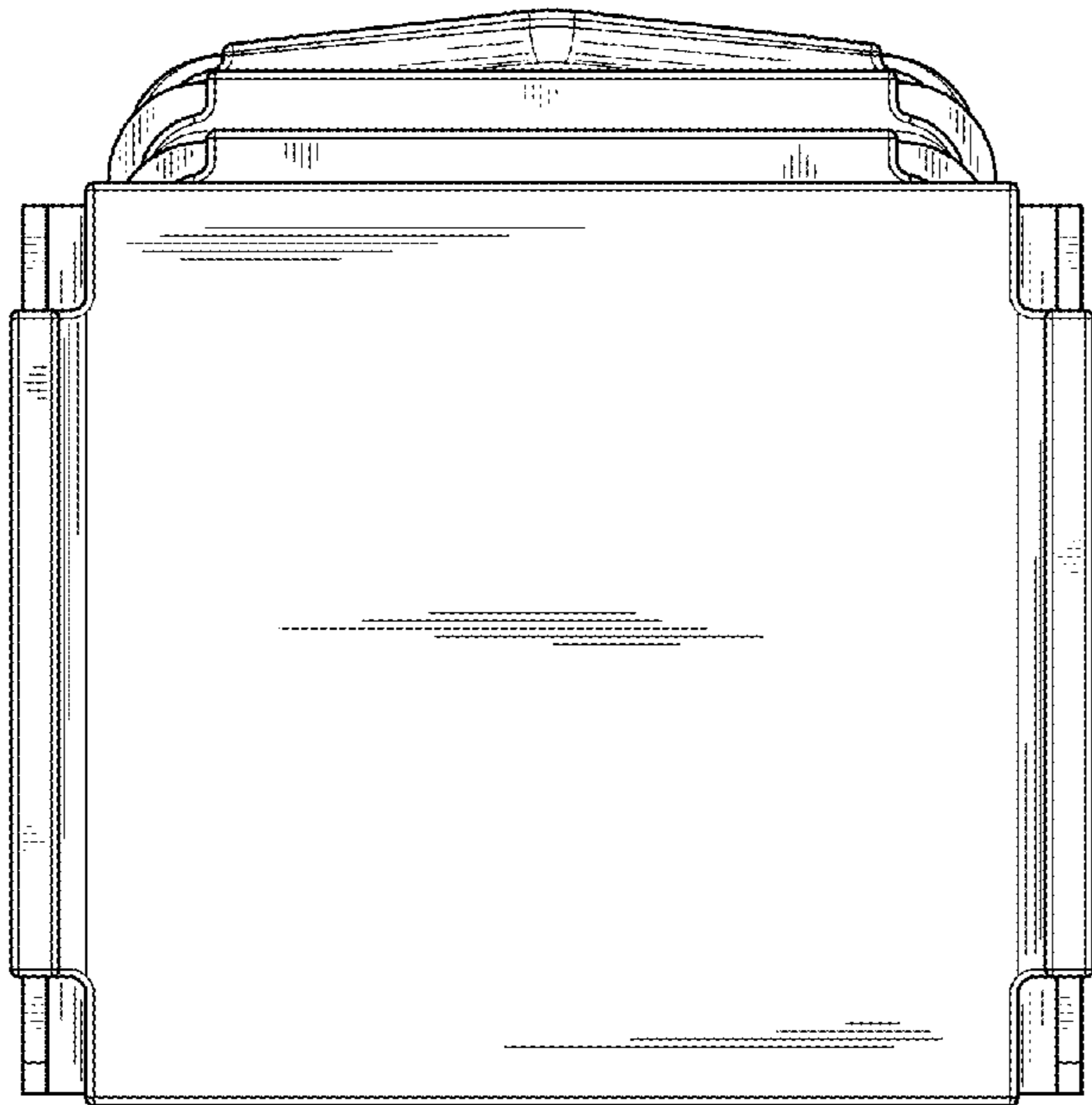

FIG. 7

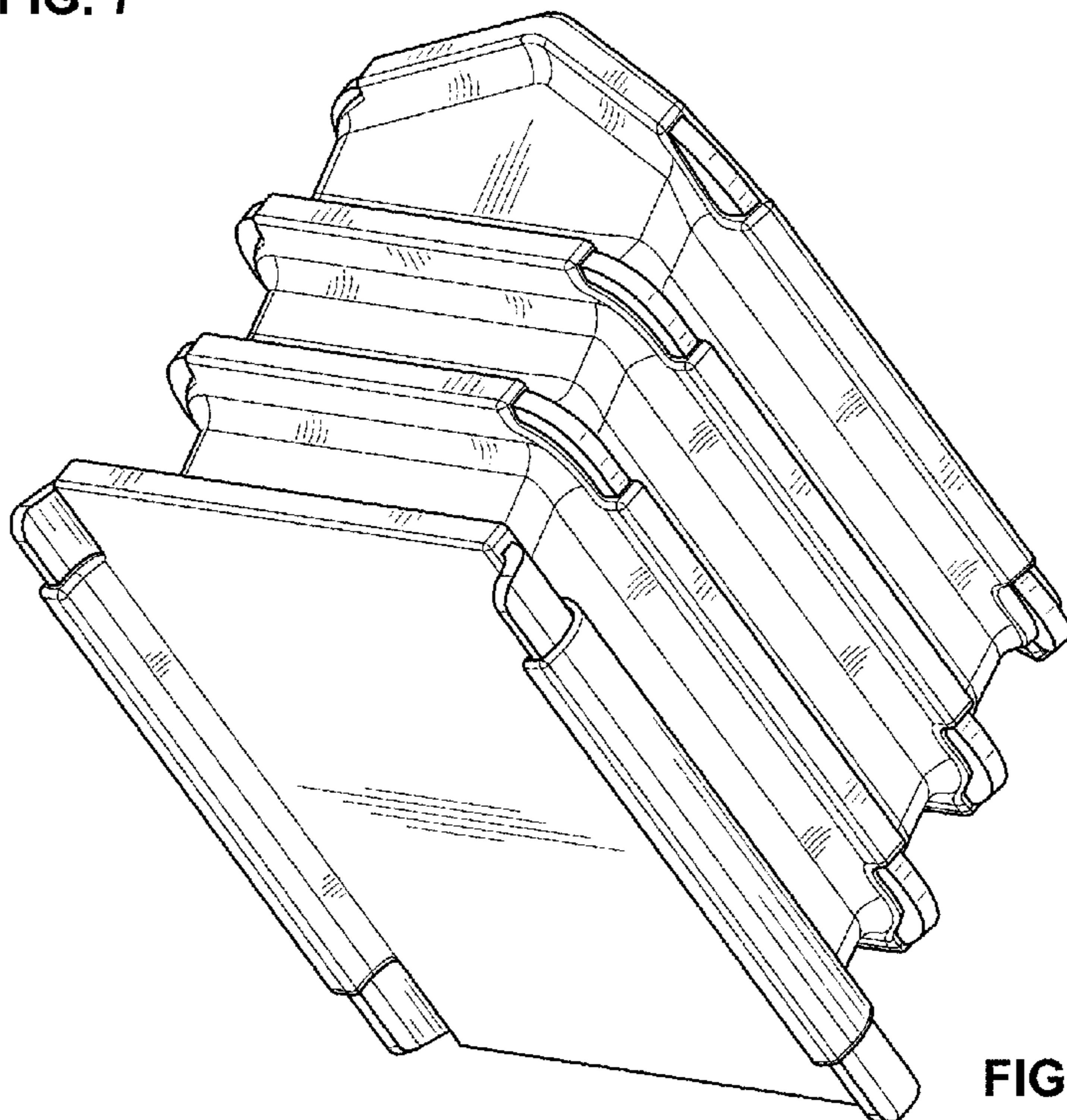

FIG. 8

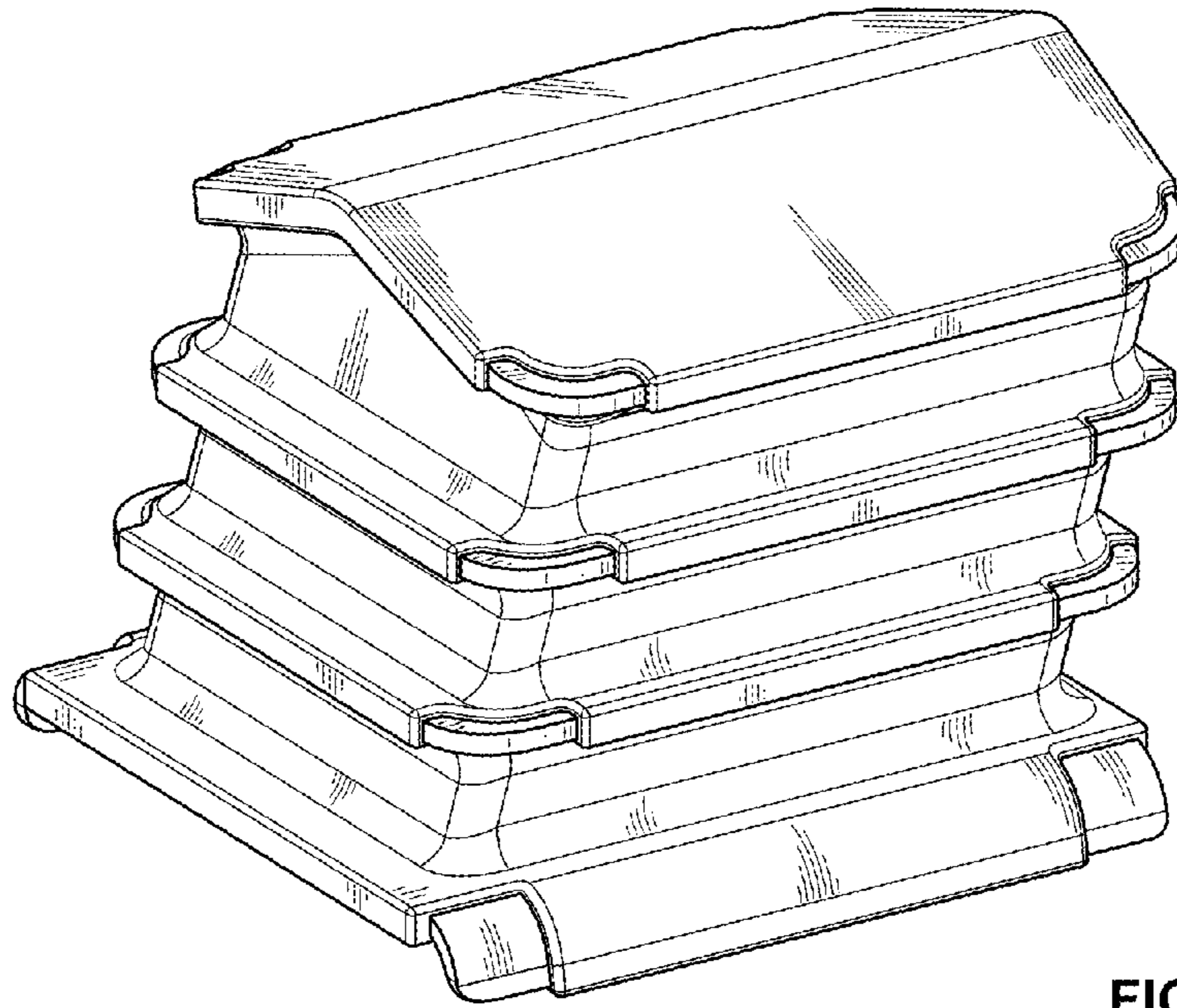

FIG. 9

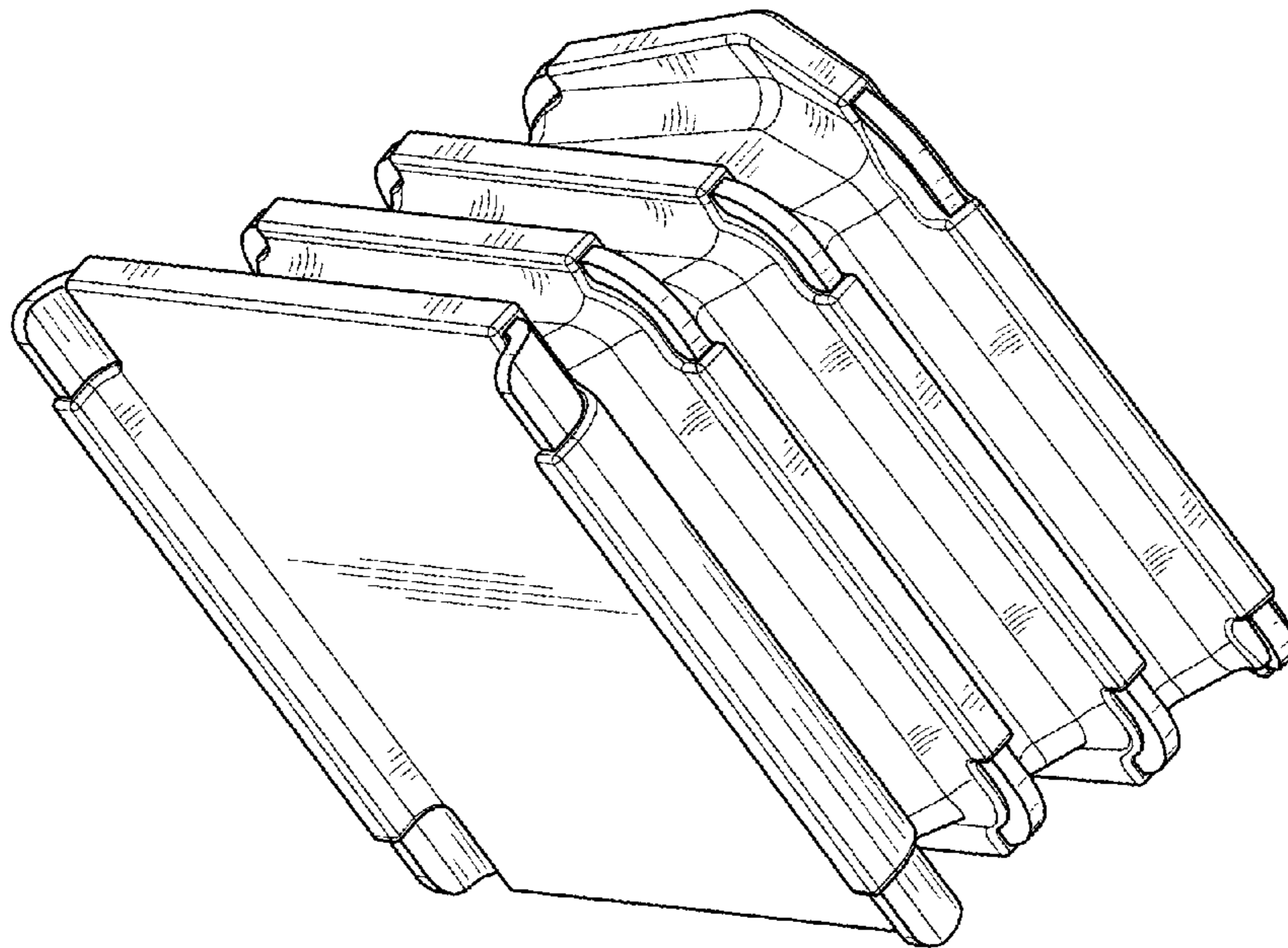

FIG. 10