

US00D698863S

(12) **United States Design Patent**
Ryan et al.

(10) **Patent No.:** **US D698,863 S**
(45) **Date of Patent:** **** Feb. 4, 2014**

(54) **CARPENTER'S PENCIL**

(76) Inventors: **Jason Ryan**, Ottawa (CA); **Nicholas Dean**, Ottawa (CA)

(**) **Term:** **14 Years**

(21) **Appl. No.:** **29/420,204**

(22) **Filed:** **May 7, 2012**

(30) **Foreign Application Priority Data**

Nov. 25, 2011 (CA) 143283

(51) **LOC (10) Cl.** **19-06**

(52) **U.S. Cl.**
USPC **D19/36**

(58) **Field of Classification Search**
USPC D14/411; D19/35, 36, 41-51, 53-58;
24/11 R, 11 F, 11 P; 401/52, 99-109,
401/192, 195, 196
See application file for complete search history.

(56) **References Cited**

U.S. PATENT DOCUMENTS

D126,555 S *	4/1941	Gurtov	D8/62
3,984,919 A *	10/1976	Guisti	33/381
D311,341 S *	10/1990	Lewis et al.	D10/62
D315,521 S *	3/1991	Greenland	D10/69
5,075,978 A *	12/1991	Crowe	33/348.2
D342,088 S *	12/1993	Sonntag et al.	D19/48
5,433,011 A *	7/1995	Scarborough et al.	33/376
5,522,146 A *	6/1996	Warburton	33/347
5,651,186 A *	7/1997	Lindner et al.	33/377
D388,719 S *	1/1998	Kohner	D10/69
5,709,034 A *	1/1998	Kohner	33/377
5,966,826 A *	10/1999	Ho	33/365

D509,762 S *	9/2005	Scheyer	D10/69
D525,543 S *	7/2006	Kallabis	D10/69
D560,521 S *	1/2008	Katz	D10/69
D573,908 S *	7/2008	Levinson	D10/69
D574,273 S *	8/2008	Dolin	D10/69
D579,045 S *	10/2008	Allemand	D19/45
D579,046 S *	10/2008	Allemand	D19/47
D598,309 S *	8/2009	Gofer	D10/69
D607,351 S *	1/2010	Gofer	D10/69
7,645,083 B2	1/2010	Burry et al.		
D645,366 S *	9/2011	Ryan	D10/69
D654,950 S *	2/2012	Ryan	D19/36
2011/0113638 A1 *	5/2011	Scheyer et al.	33/379
2012/0134736 A1 *	5/2012	Ryan	401/52

* cited by examiner

Primary Examiner — Elizabeth Albert

(74) *Attorney, Agent, or Firm* — Haugen Law Firm PLLP

(57) **CLAIM**

The ornamental design for a carpenter's pencil, as shown and described.

DESCRIPTION

FIG. 1 is a front perspective view of a carpenter's pencil showing our new design;

FIG. 2 is a front elevational view of FIG. 1;

FIG. 3 is a rear elevational view of FIG. 1;

FIG. 4 is a top plan view of FIG. 1;

FIG. 5 is a bottom plan view of FIG. 1;

FIG. 6 is a left side elevational view of FIG. 1; and,

FIG. 7 is a right side elevational view of FIG. 1.

The broken line showing of environmental structure is for illustrative purposes only, and forms no part of the claimed design,

1 Claim, 2 Drawing Sheets

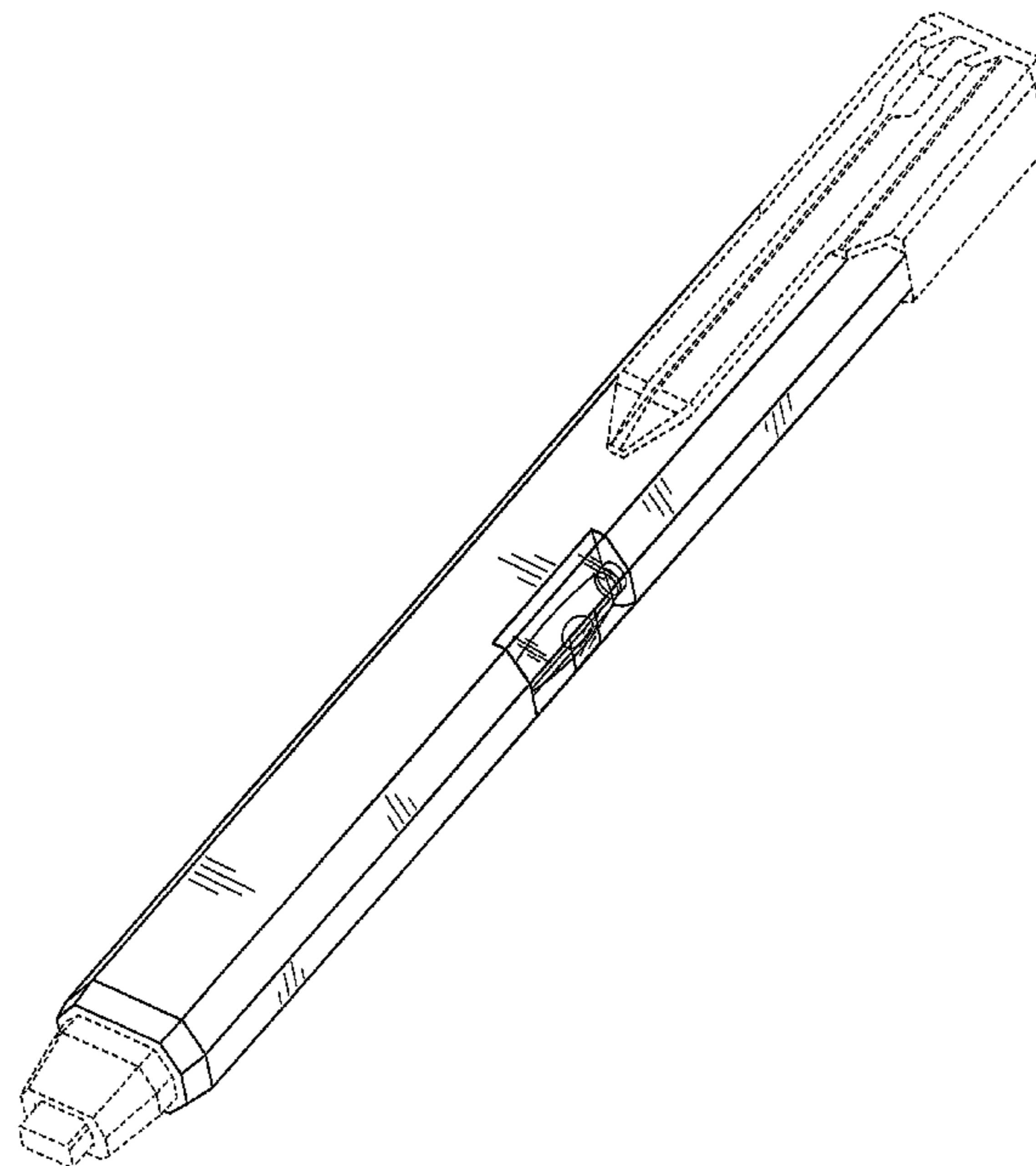

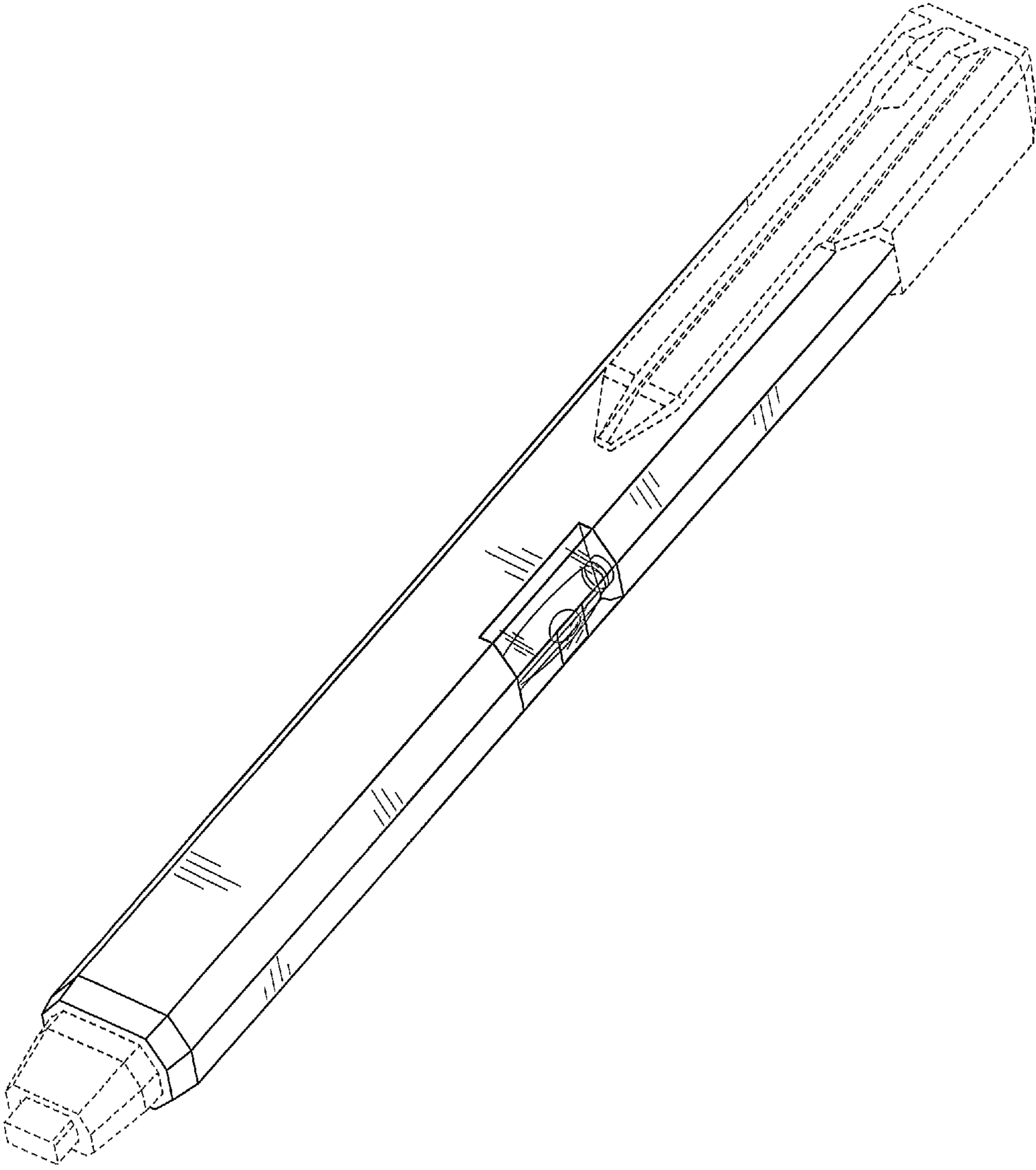

FIG. 1

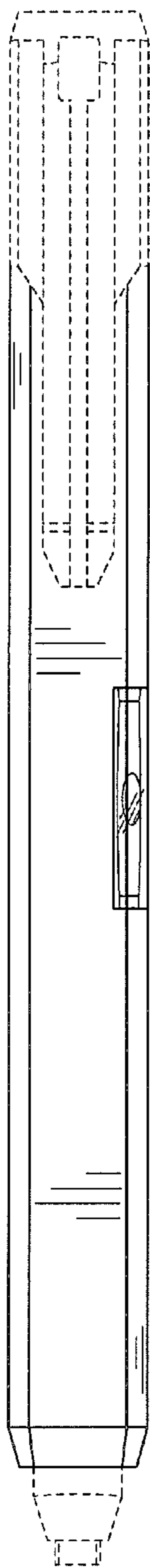

FIG. 2

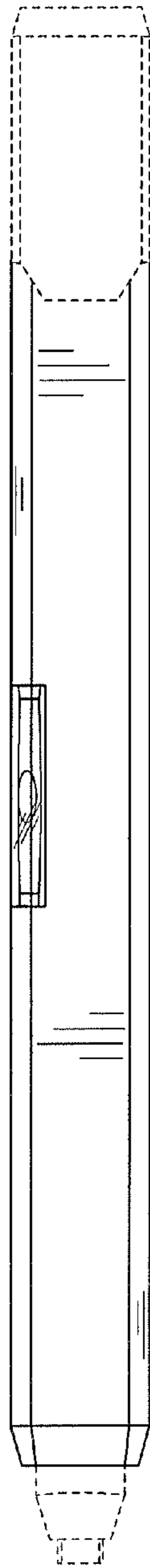

FIG. 3

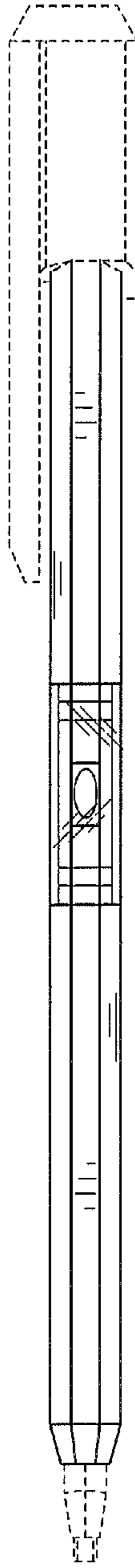

FIG. 4

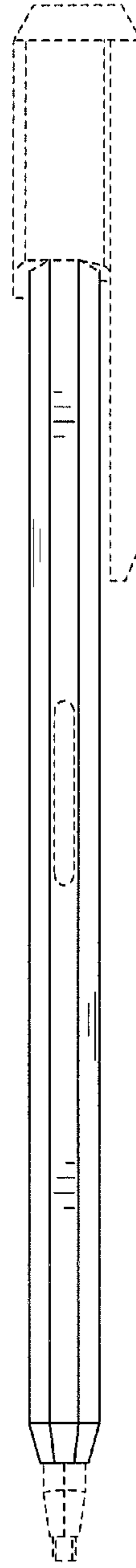

FIG. 5

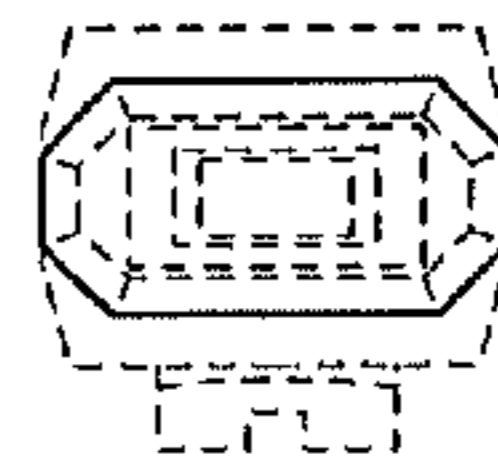

FIG. 6



FIG. 7