

US00D698601S

(12) **United States Design Patent**
Harris

(10) **Patent No.:** **US D698,601 S**

(45) **Date of Patent:** **** Feb. 4, 2014**

(54) **BEVERAGE BOTTLE**

(71) Applicant: **Neil Harris**, Fontana, CA (US)

(72) Inventor: **Neil Harris**, Fontana, CA (US)

(73) Assignee: **Flashbang, Inc.**, Fontana, CA (US)

(**) Term: **14 Years**

(21) Appl. No.: **29/433,006**

(22) Filed: **Sep. 24, 2012**

(51) **LOC (10) Cl.** **07-01**

(52) **U.S. Cl.**
USPC **D7/515**; D7/511; D7/510; D9/680

(58) **Field of Classification Search**
USPC D7/510, 511, 509, 523, 608, 316, 317,
D7/300.1, 376, 378, 412; 366/130, 247;
220/703, 592.16, 592.17, 739; 99/287;
D23/209, 207; 210/205; 102/498;
D9/680, 551; D22/112

See application file for complete search history.

(56) **References Cited**

U.S. PATENT DOCUMENTS

D50,589 S *	4/1917	Recker	D7/608
5,590,542 A *	1/1997	Wang	62/457.3
D425,374 S *	5/2000	Besser et al.	D7/608
D457,034 S *	5/2002	Bodum	D7/510
D457,783 S *	5/2002	Bodum	D7/511
D471,764 S *	3/2003	Janky	D7/510
6,595,139 B1 *	7/2003	Haeselich	102/498
D488,960 S *	4/2004	Wahl et al.	D7/608
D501,362 S *	2/2005	Gauss	D7/510
D533,747 S *	12/2006	Jin	D7/510
D543,782 S *	6/2007	Elkhatib	D7/510
D557,562 S *	12/2007	Kramer et al.	D7/533
7,322,296 B2 *	1/2008	Ellis	102/498

D594,088 S *	6/2009	Pritchard	D23/207
D612,202 S *	3/2010	Hillebrenner	D7/396.2
D615,816 S *	5/2010	Joy et al.	D7/507
D620,756 S *	8/2010	Lown et al.	D7/510
D629,653 S *	12/2010	Gullickson et al.	D7/510
7,963,227 B1 *	6/2011	Brunn	102/498
D651,044 S *	12/2011	Gilbert	D7/510
D658,445 S *	5/2012	Carreno	D7/510
D658,446 S *	5/2012	George	D7/608
D658,448 S *	5/2012	Ying	D7/608
D660,177 S *	5/2012	Ferenc	D9/680
D678,727 S *	3/2013	Kolar	D7/533
D683,235 S *	5/2013	Albert	D9/680
8,453,573 B1 *	6/2013	McKimm et al.	102/487
8,464,895 B2 *	6/2013	Gilbert et al.	220/703

* cited by examiner

Primary Examiner — Marianne Pandozzi

(74) *Attorney, Agent, or Firm* — Marc E. Hankin; Kevin Schraven; Jimmy Sauz

(57) **CLAIM**

The ornamental design for a beverage bottle, as shown and described.

DESCRIPTION

FIG. 1 is a top right side perspective view of a beverage bottle showing my new design;

FIG. 2 is an exploded perspective view thereof in open position with pin removed;

FIG. 3 is a right side perspective view of FIG. 1;

FIG. 4 is a left side perspective view of FIG. 1;

FIG. 5 is a front perspective view of FIG. 1;

FIG. 6 is a rear perspective view of FIG. 1;

FIG. 7 is a bottom right side perspective view thereof; and,

FIG. 8 is a top plan view thereof.

The broken lines in the drawings depict unclaimed subject matter and form no part of the claimed design.

1 Claim, 8 Drawing Sheets

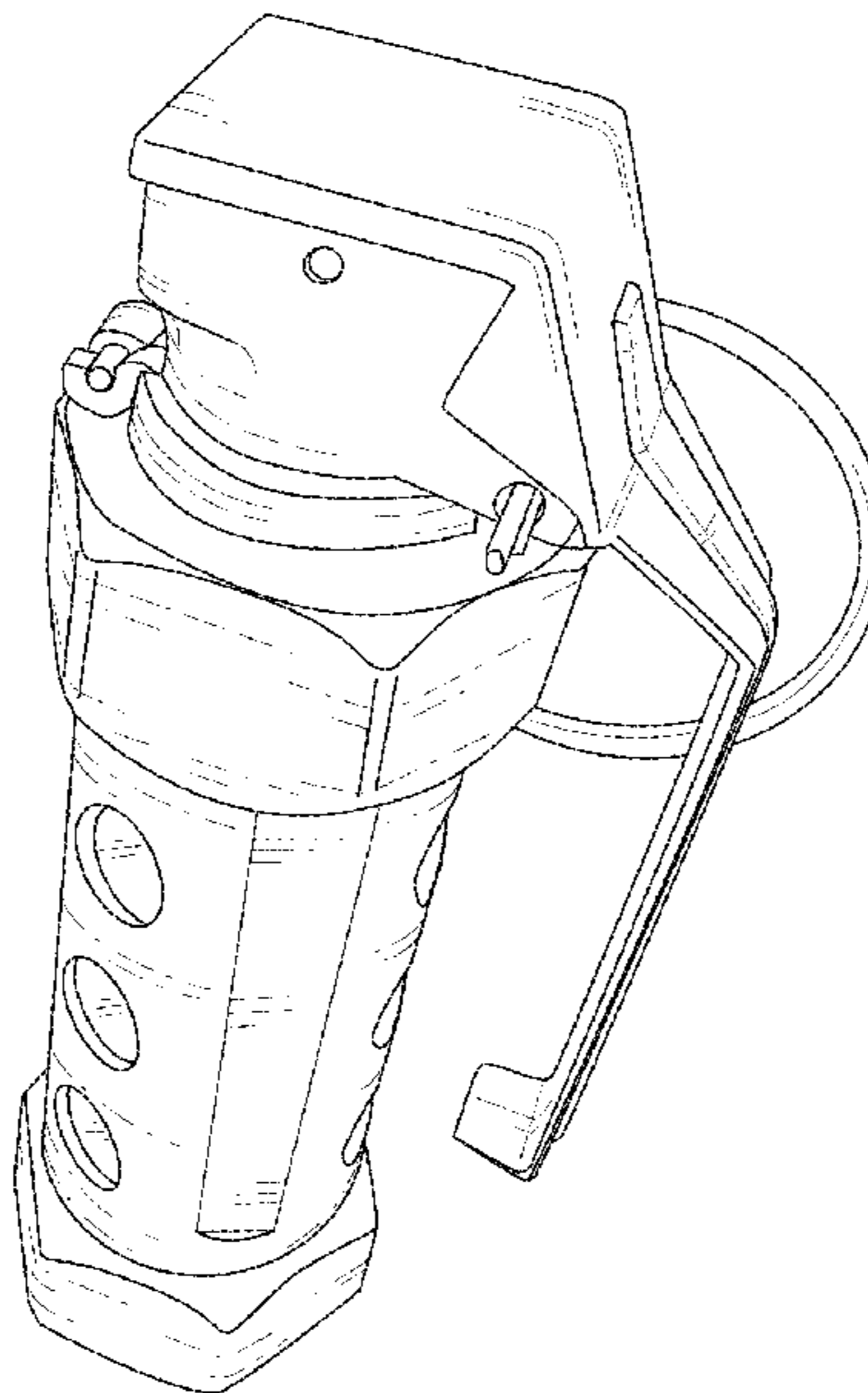

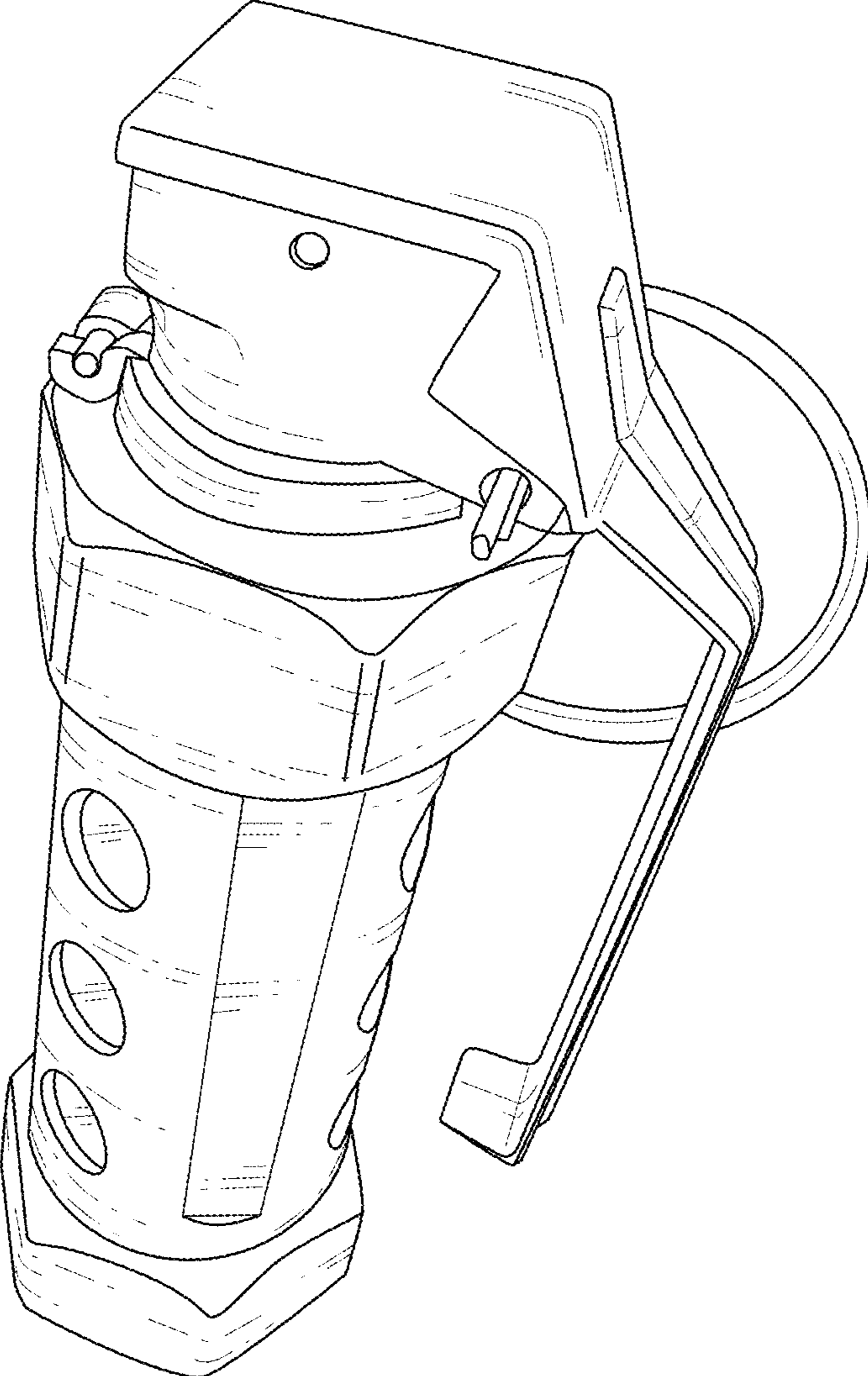

FIG. 1

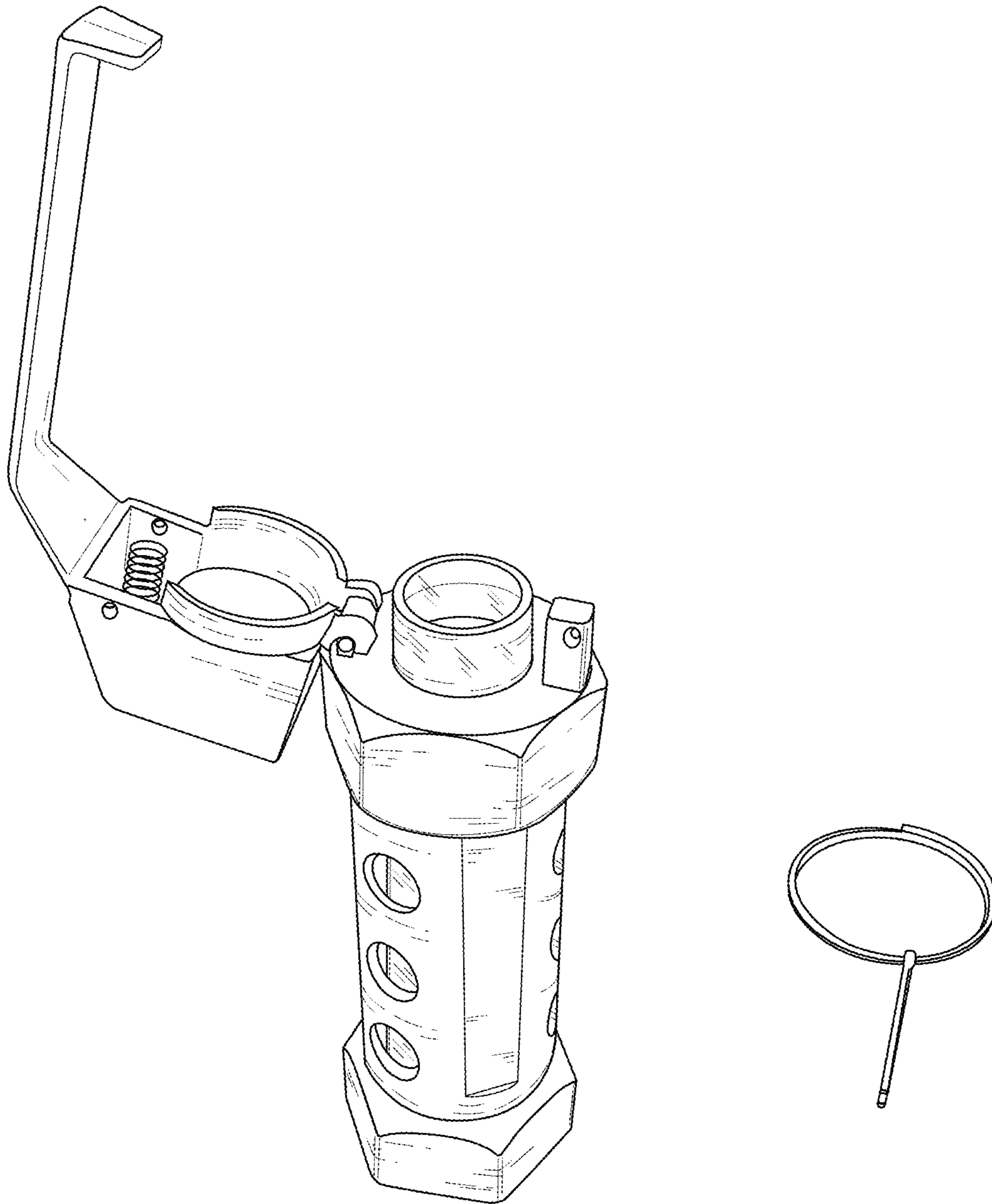

FIG. 2

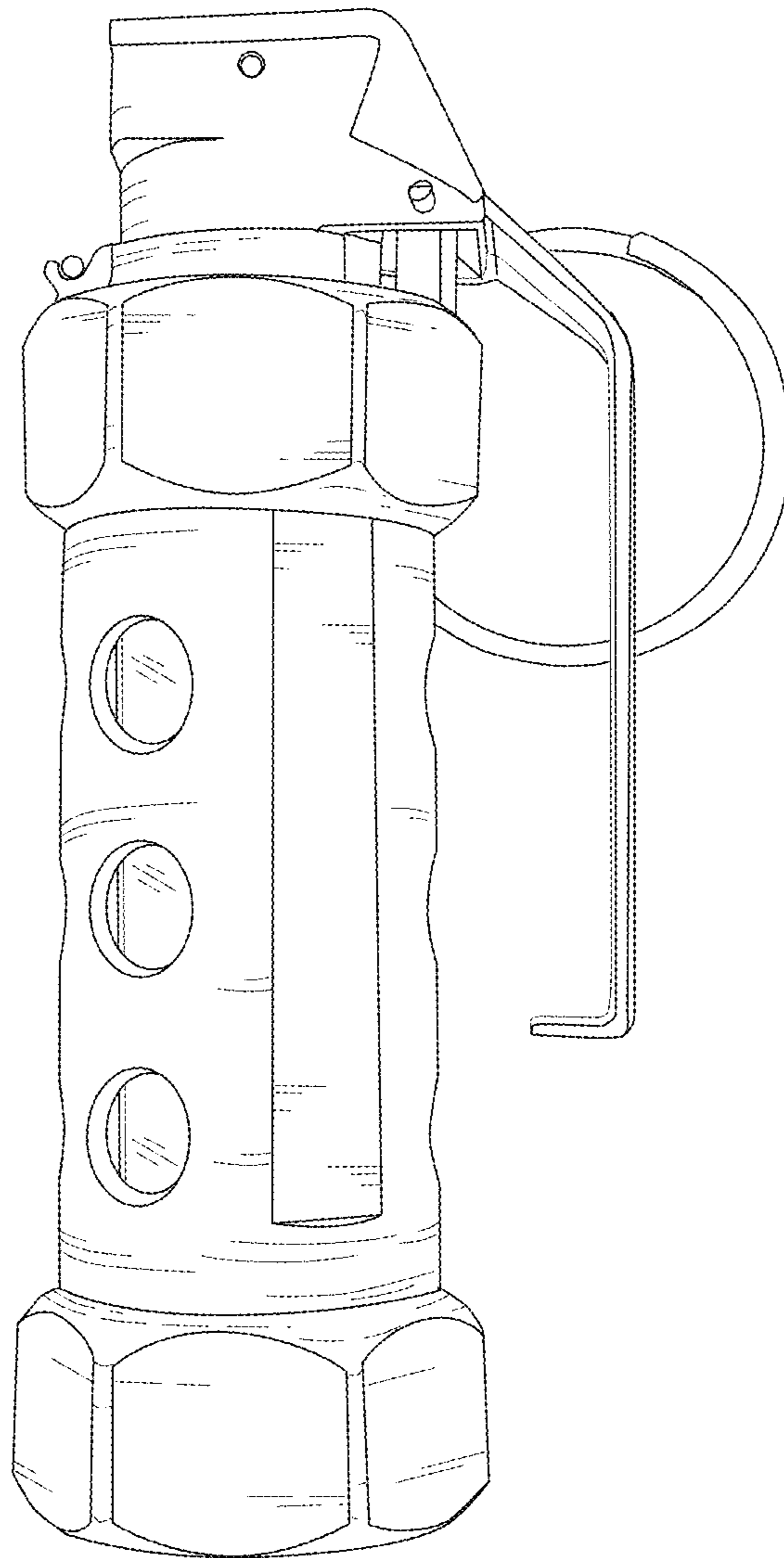

FIG. 3

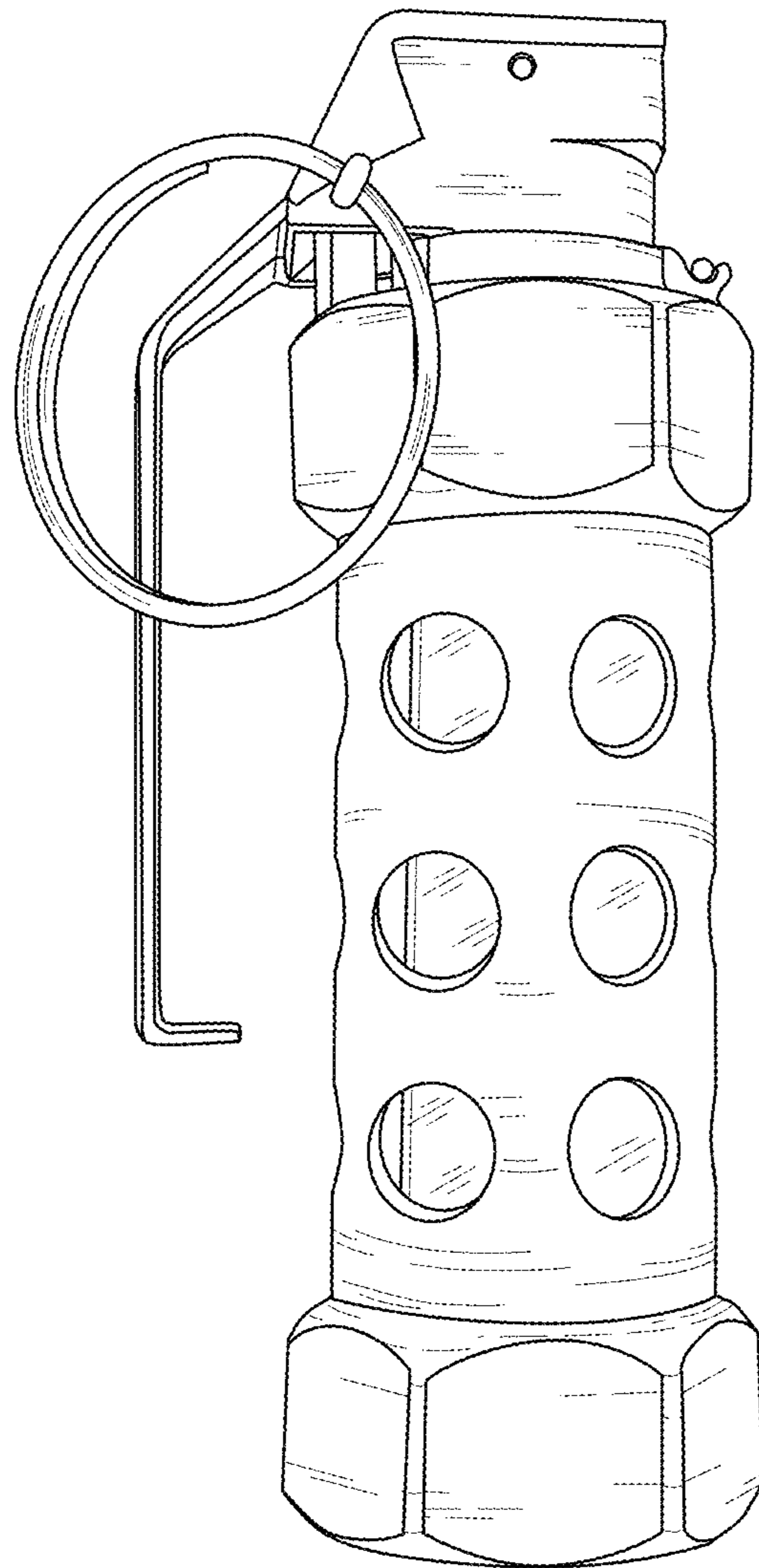

FIG. 4

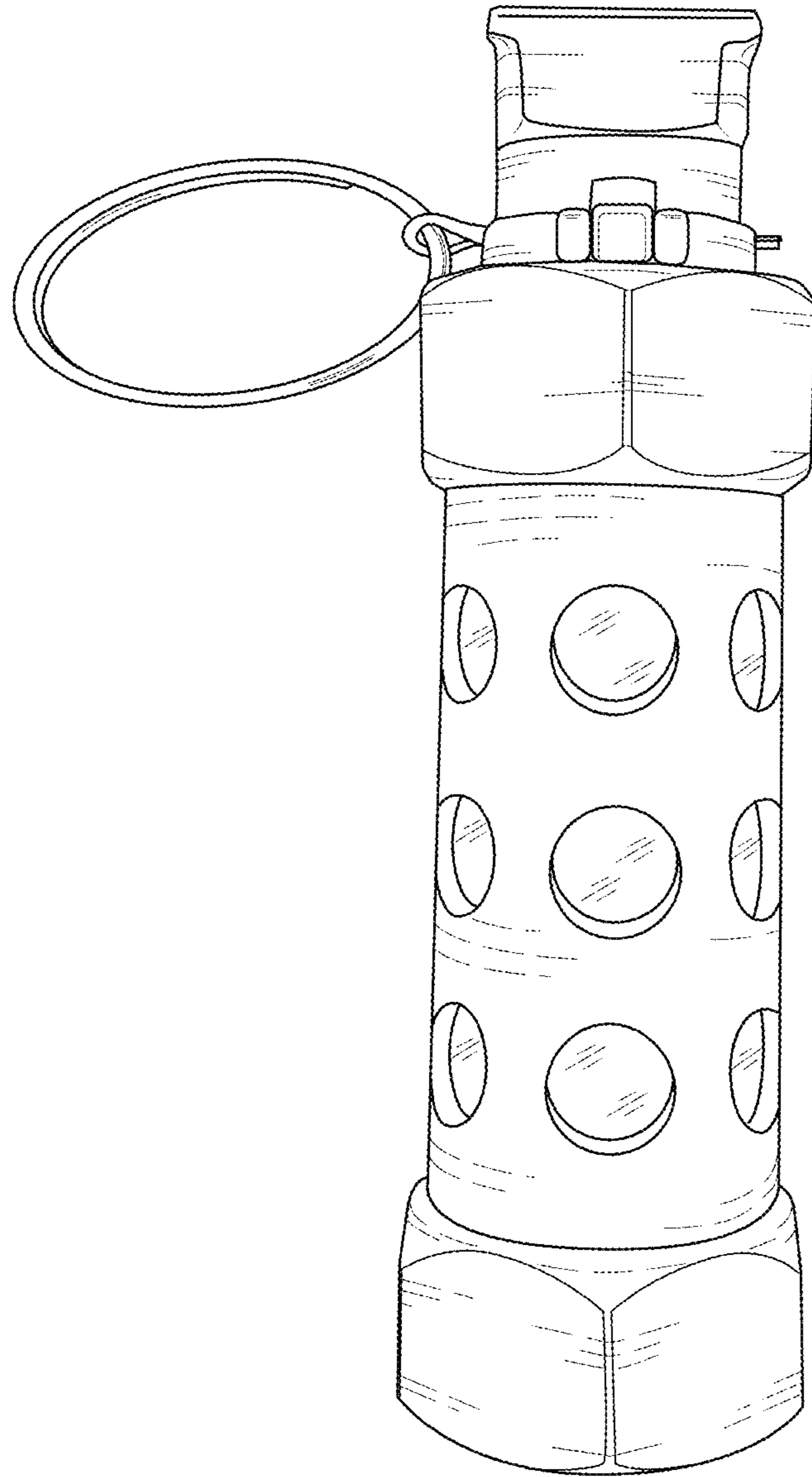

FIG. 5

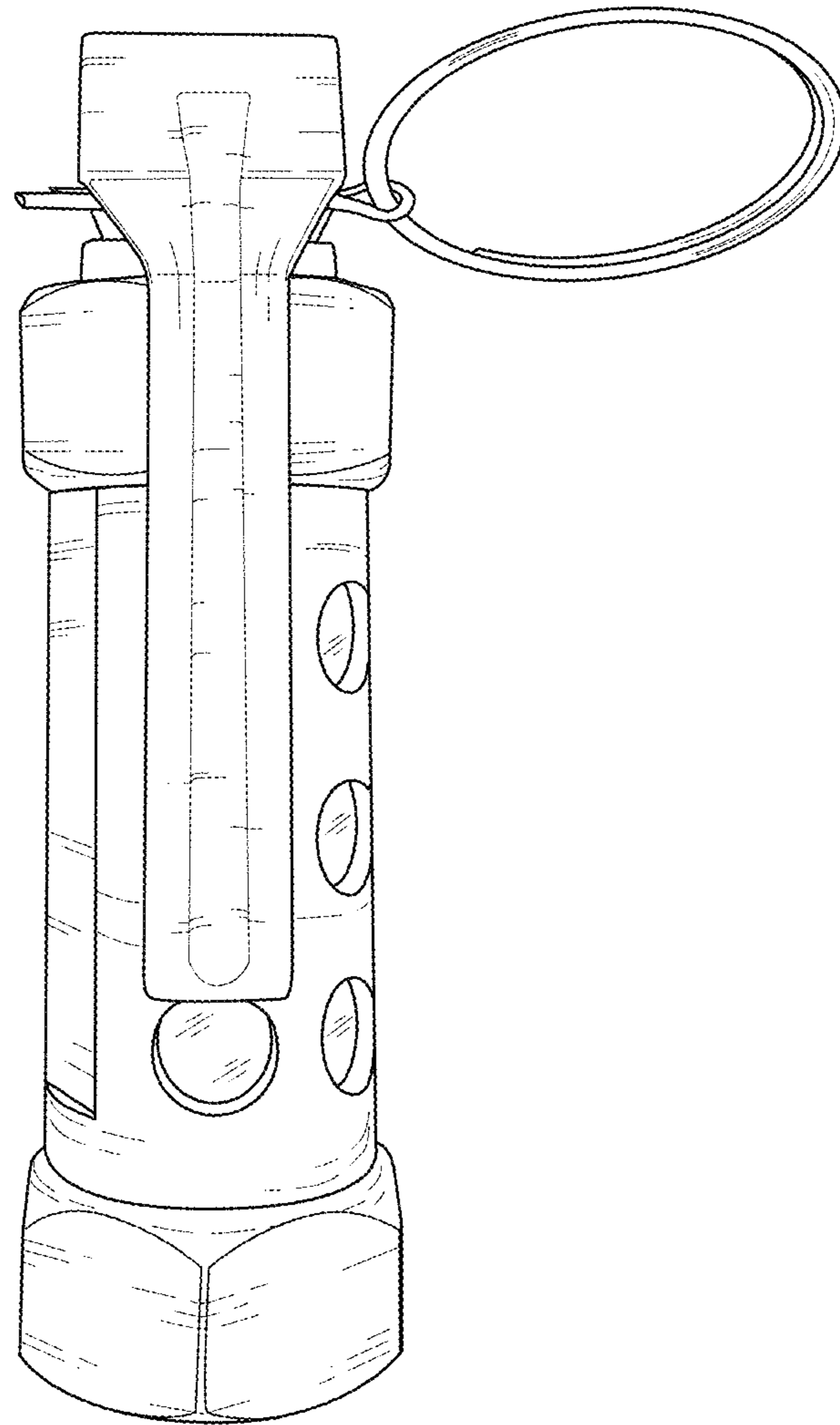

FIG. 6

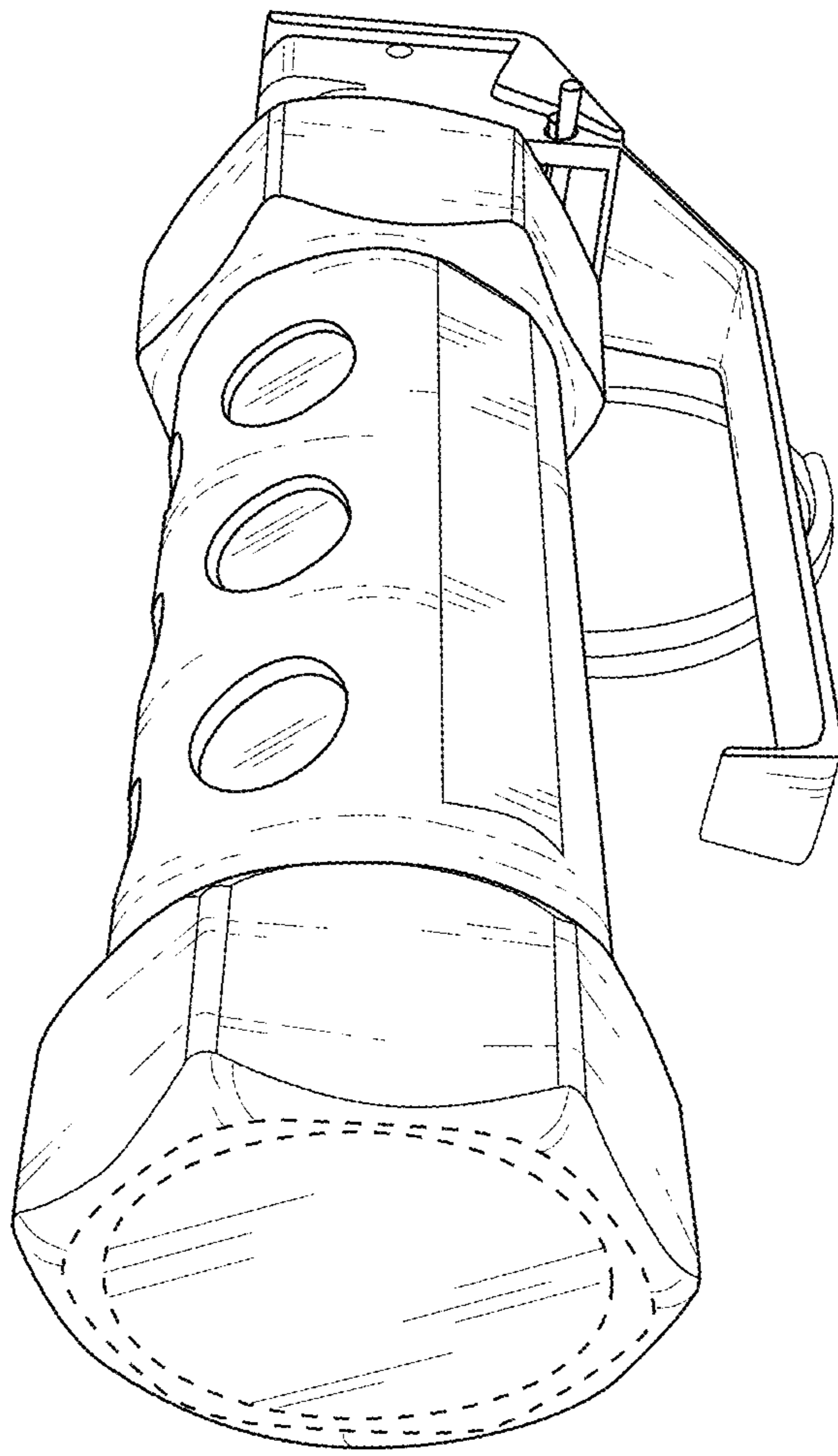

FIG. 7

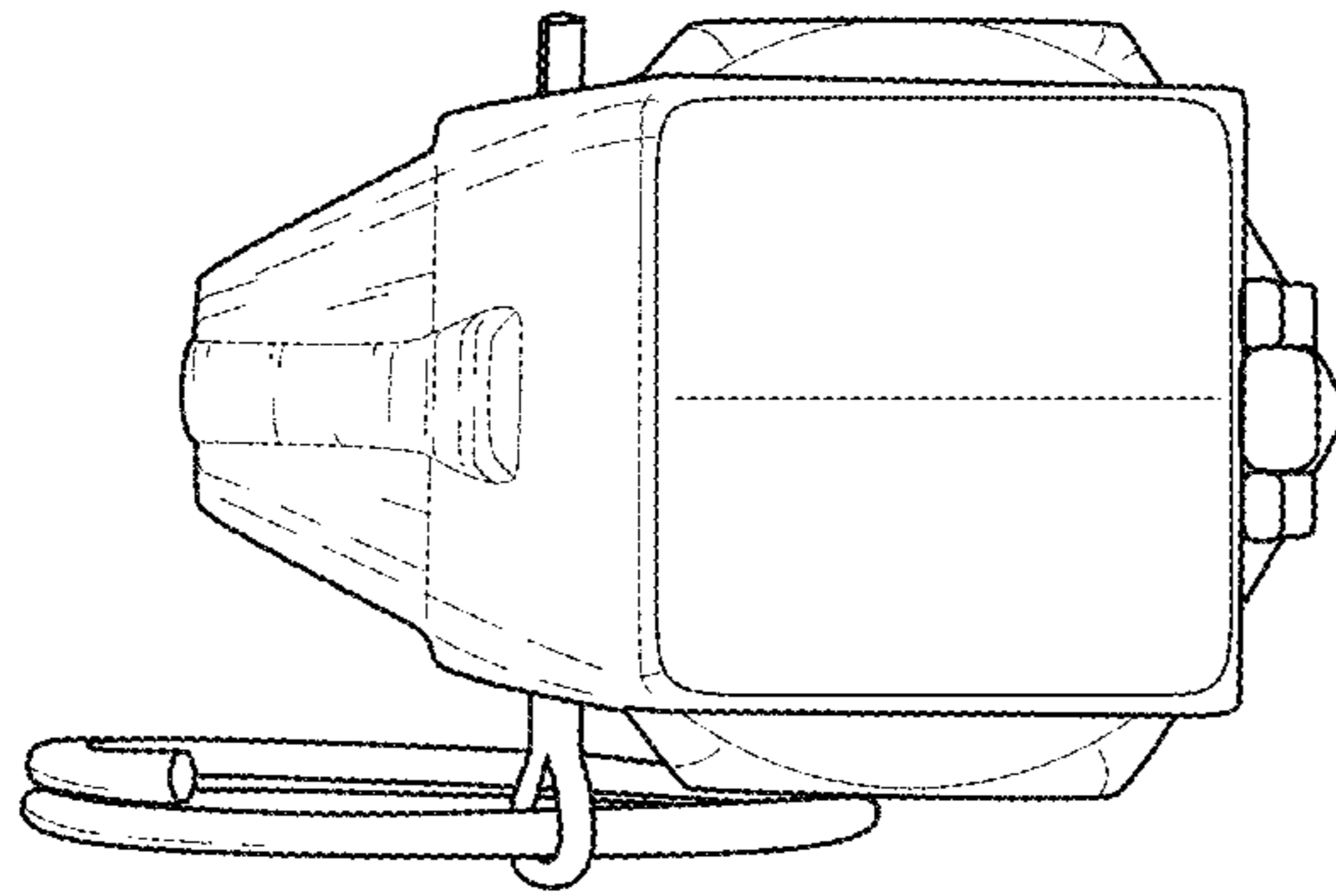

FIG. 8