

US00D698393S

(12) **United States Design Patent**  
**Marukos**

(10) **Patent No.:** **US D698,393 S**  
(45) **Date of Patent:** **\*\* Jan. 28, 2014**

(54) **MAGNETIC SIGN SLEEVE**  
(76) Inventor: **Chris Marukos**, Deerfield Beach, FL  
(US)  
(\*\*) Term: **14 Years**  
(21) Appl. No.: **29/416,464**  
(22) Filed: **Mar. 22, 2012**  
(51) **LOC (10) Cl.** ..... **20-03**  
(52) **U.S. Cl.**  
USPC ..... **D20/43**  
(58) **Field of Classification Search**  
USPC ..... D20/10, 19, 40, 43, 44, 99; 40/490,  
40/491, 591, 594, 600, 642.02, 643, 644,  
40/649-651, 654.01, 655, 658, 661,  
40/661.01, 661.08, 661.09, 661.11, 700,  
40/711; D3/247, 300; D9/702, 707, 711;  
D19/86; 150/147; 229/76; 383/38, 43,  
383/51, 61.2, 63, 66, 93, 106, 109;  
428/35.2

See application file for complete search history.

(56) **References Cited**

**U.S. PATENT DOCUMENTS**

2,344,369	A *	3/1944	Salfisberg	.....	383/109
2,725,913	A *	12/1955	Horwin	.....	150/147
2,925,675	A *	2/1960	Lumpkin	.....	40/643
3,053,386	A *	9/1962	Schlayer et al.	.....	206/63.3
3,734,394	A *	5/1973	Dooley	.....	383/109
3,826,026	A	7/1974	Bevan		
4,087,002	A *	5/1978	Bambara et al.	.....	206/523
D325,048	S	3/1992	Penner		
5,245,775	A *	9/1993	Goserud	.....	40/654.01
5,274,937	A	1/1994	Birnbaum		
5,309,659	A	5/1994	Eastman		
5,680,709	A	10/1997	Stone		
5,904,373	A *	5/1999	Krapf	.....	281/29
6,012,844	A *	1/2000	Huseman et al.	.....	383/93

6,108,957	A *	8/2000	Zapawa	.....	40/654.01
6,217,958	B1	4/2001	Blyden		
6,575,627	B2 *	6/2003	Huseman et al.	.....	383/38
6,578,304	B1 *	6/2003	Lytle	.....	40/711
D509,955	S *	9/2005	Williams	.....	D3/247
7,137,736	B2 *	11/2006	Pawloski et al.	.....	383/61.2
D613,338	S	4/2010	Marukos		
8,166,688	B1 *	5/2012	Fragnoli	.....	40/661
D670,343	S *	11/2012	Byford	.....	D20/43
D688,564	S *	8/2013	LaFauci	.....	D9/703
2005/0155265	A1	7/2005	Coleman-Chang		
2005/0183613	A1	8/2005	Huffman		
2005/0284011	A1	12/2005	Todd		
2007/0289186	A1 *	12/2007	Wallace	.....	40/661
2013/0037187	A1 *	2/2013	D'Amore et al.	.....	150/147

\* cited by examiner

*Primary Examiner* — Mary Ann Calabrese

(57) **CLAIM**

I claim the ornamental design for the magnetic sign sleeve, as shown and described.

**DESCRIPTION**

FIG. 1 is a front view of the magnetic sign sleeve.  
FIG. 2 is a rear view of the claimed design.  
FIG. 3 is a left side view of the claimed design.  
FIG. 4 is a top view of the claimed design.  
FIG. 5 is a bottom view of the claimed design.  
FIG. 6 is a perspective view of the claimed design in which an advertisement is partially inserted into a slot having closure means along a top edge; and,  
FIG. 7 is a perspective view of the claimed design in use along a surface of a vehicle and with an advertisement fully inserted into the interior of the sleeve.  
It shall be noted that the both the advertisement, letters forming the word "LOGO", and said vehicle are all being depicted in broken lines, which is environmental matter forming no part of the claimed design.

**1 Claim, 5 Drawing Sheets**

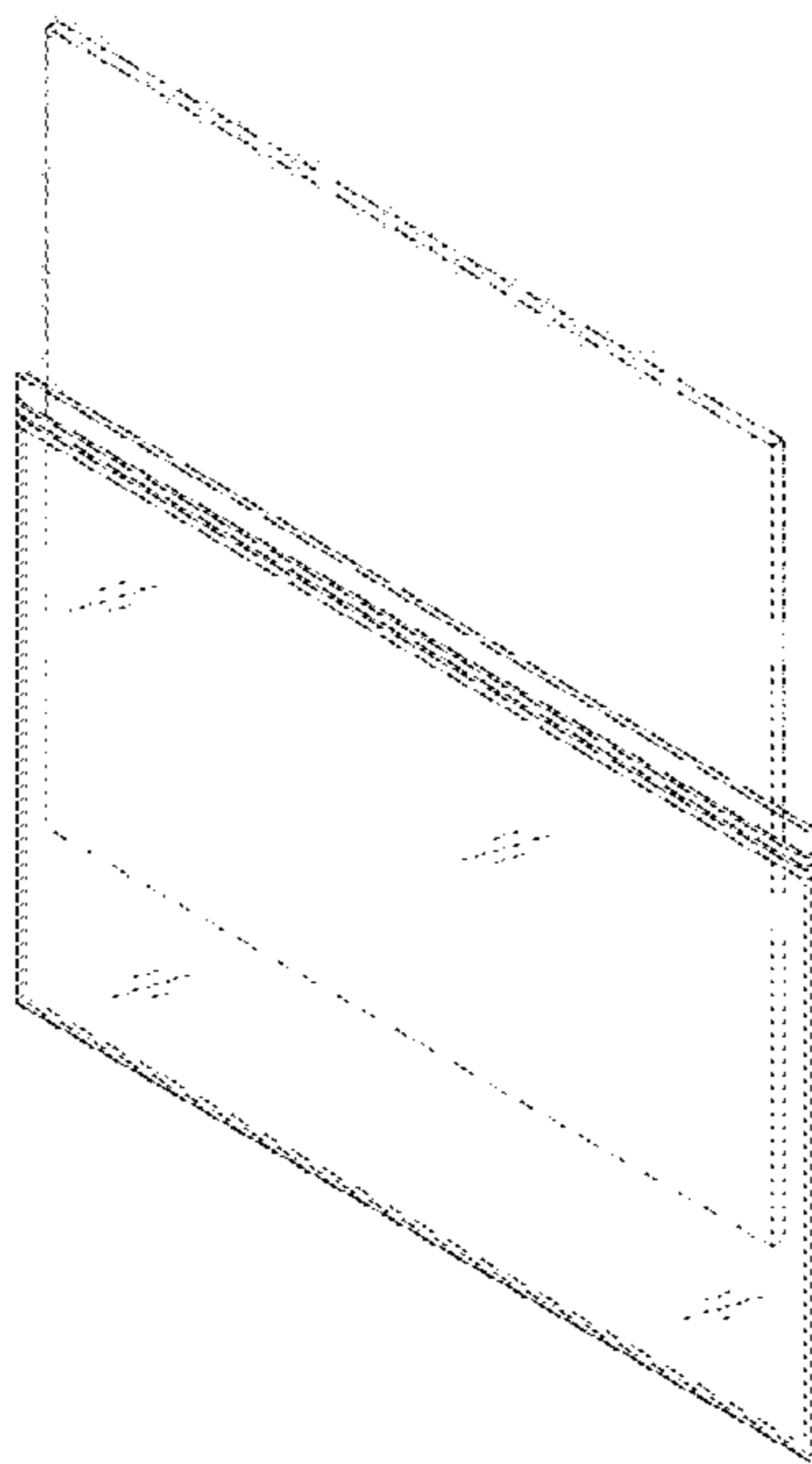

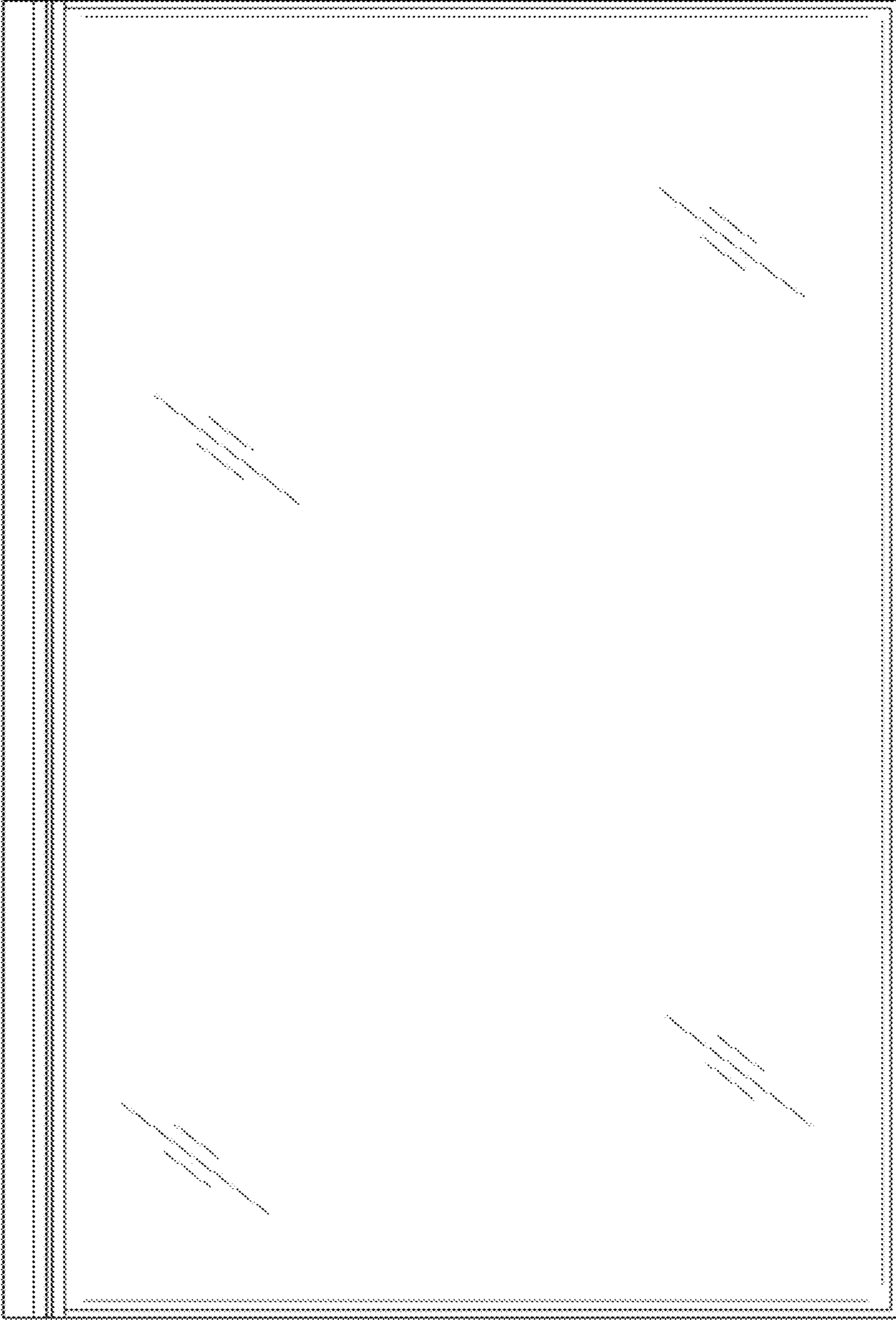

FIG. 1

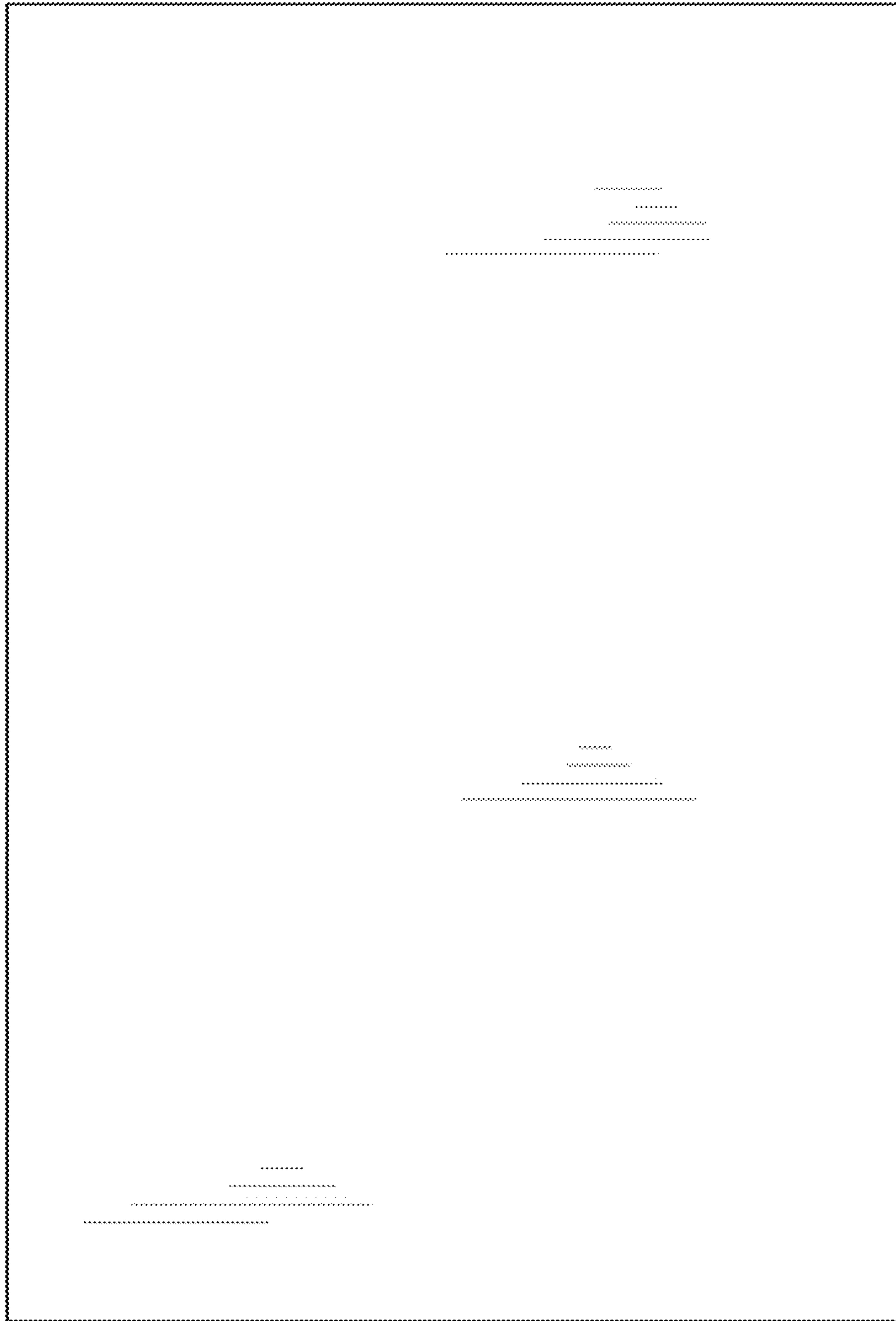

FIG. 2

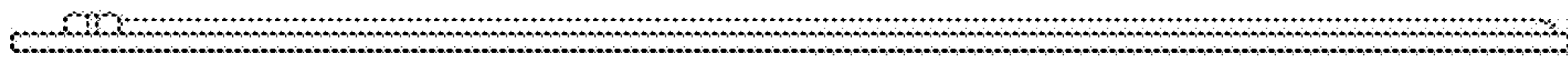

FIG. 3

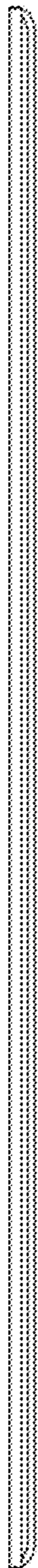

FIG. 4

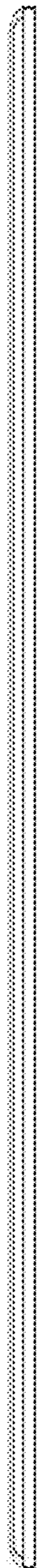

FIG. 5

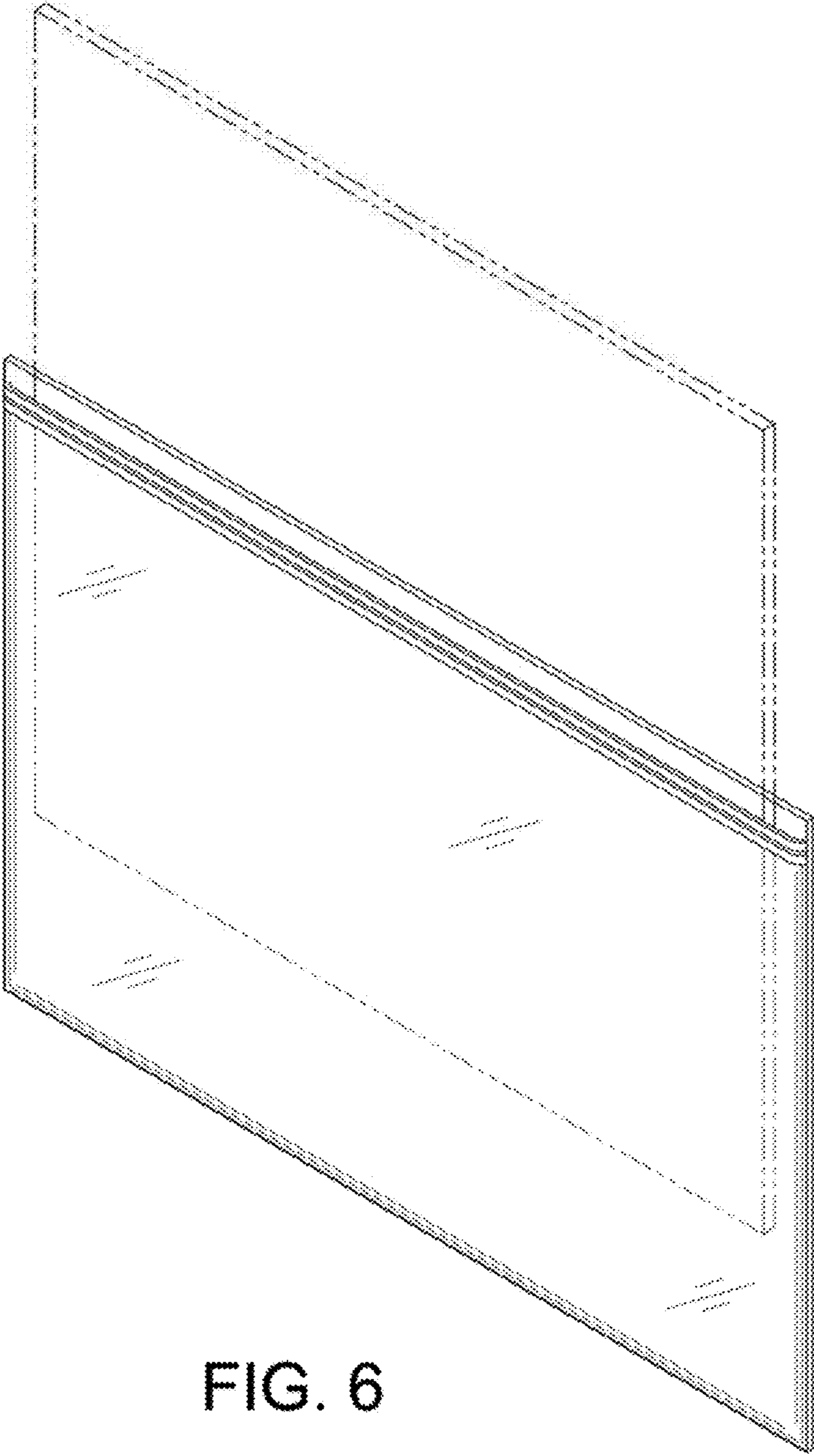

FIG. 6

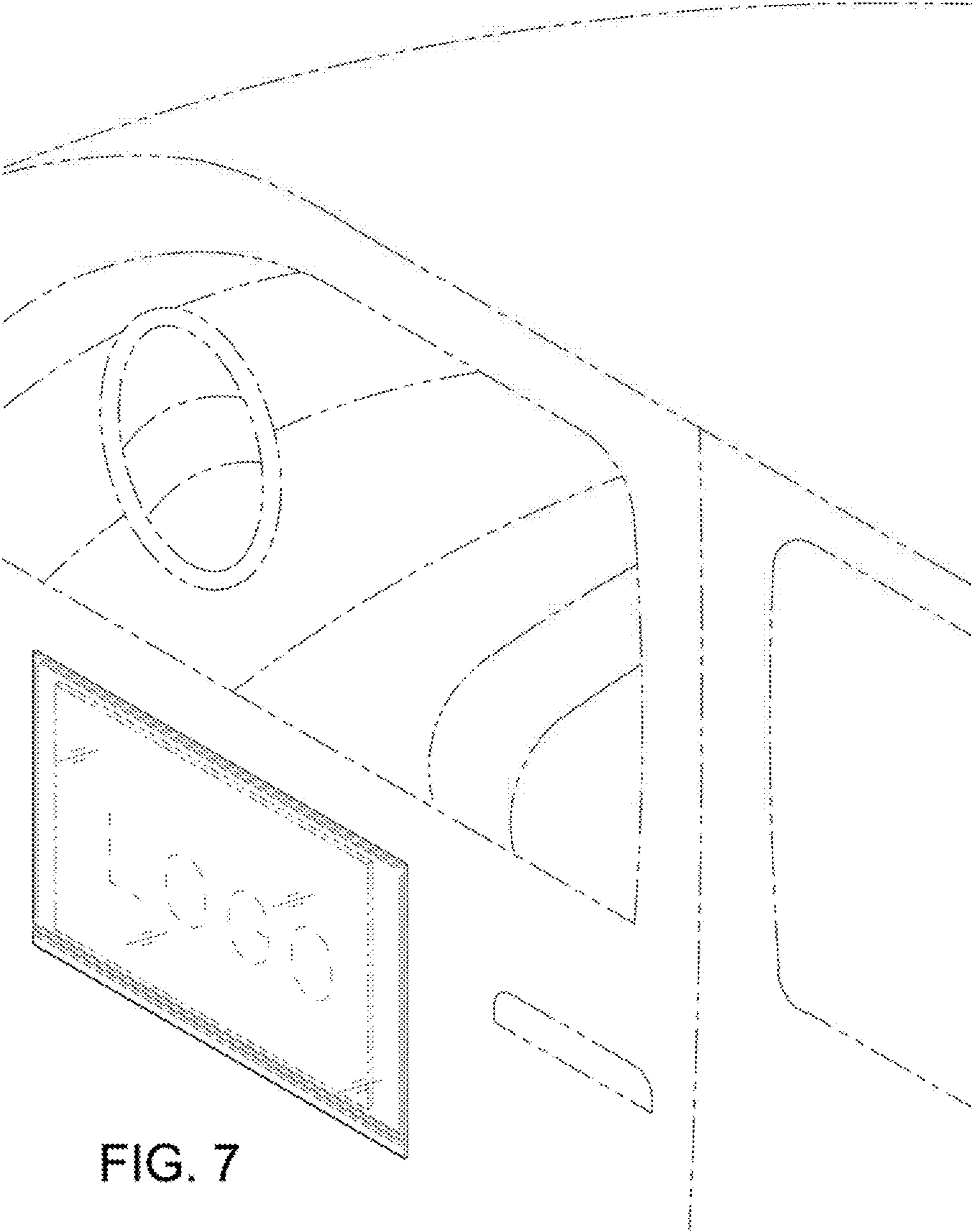

FIG. 7