



US00D698313S

(12) **United States Design Patent**  
**Buetow et al.**

(10) **Patent No.:** **US D698,313 S**  
(45) **Date of Patent:** **\*\* Jan. 28, 2014**

(54) **BATTERY PACK FOR A COMBUSTION TOOL**

(71) Applicants: **Robert Scott Buetow**, Lake in the Hills, IL (US); **William Joseph Heinzen**, Glenview, IL (US); **Claudia Perez**, Nuevo Leon (MX)

(72) Inventors: **Robert Scott Buetow**, Lake in the Hills, IL (US); **William Joseph Heinzen**, Glenview, IL (US); **Claudia Perez**, Nuevo Leon (MX)

(73) Assignee: **Illinois Tool Works Inc.**, Glenview, IL (US)

(\*\*) Term: **14 Years**

(21) Appl. No.: **29/459,326**

(22) Filed: **Jun. 28, 2013**

**Related U.S. Application Data**

(62) Division of application No. 29/387,140, filed on Mar. 9, 2011.

(51) **LOC (10) Cl.** ..... **13-02**

(52) **U.S. Cl.**  
USPC ..... **D13/119**

(58) **Field of Classification Search**  
USPC ..... D13/102-108, 110, 118-121, 184, 199;  
429/96-100, 163, 176  
See application file for complete search history.

(56) **References Cited**

**U.S. PATENT DOCUMENTS**

D313,391 S 1/1991 Pudwill  
D320,379 S 10/1991 Culbertson  
D323,642 S 2/1992 Liao  
D352,698 S 11/1994 Okumura

D383,435 S 9/1997 Svetlik  
D384,031 S 9/1997 Lui  
D384,032 S 9/1997 Lui  
D417,860 S 12/1999 Lau  
D435,827 S 1/2001 Rausch et al.  
D490,052 S 5/2004 Zufall et al.  
D537,408 S \* 2/2007 Aglassinger ..... D13/103  
D547,264 S 7/2007 Kondo  
7,306,878 B2 12/2007 Takeshita et al.  
D559,175 S 1/2008 Houghton  
D562,759 S 2/2008 Fitch et al.  
D597,482 S 8/2009 Kondo et al.  
D604,235 S 11/2009 Tarter  
D613,244 S 4/2010 Palmer et al.  
D624,011 S \* 9/2010 Bertagnole et al. .... D13/103  
D631,835 S \* 2/2011 Neidhart ..... D13/103  
D635,507 S 4/2011 Ueda et al.  
D647,050 S 10/2011 Tu  
8,415,046 B2 4/2013 Kondo

\* cited by examiner

*Primary Examiner* — Rosemary K Tarcza

(74) *Attorney, Agent, or Firm* — Greer, Burns & Crain, Ltd.; Patty Chidiac; Mark W. Croll

(57) **CLAIM**

The ornamental design for a battery pack for a combustion tool, as shown and described.

**DESCRIPTION**

FIG. 1 is a top perspective view of present battery pack; FIG. 2 is a right side view of the battery pack of FIG. 1; FIG. 3 is a left side view of same; FIG. 4 is a front view of the battery pack of FIG. 1; FIG. 5 is a rear view of same; FIG. 6 is top view of the battery pack of FIG. 1; and, FIG. 7 is a bottom view of same.  
The broken lines shown in the drawings are included for the purpose of illustrating environmental structure and form no part of the claimed design.

**1 Claim, 4 Drawing Sheets**

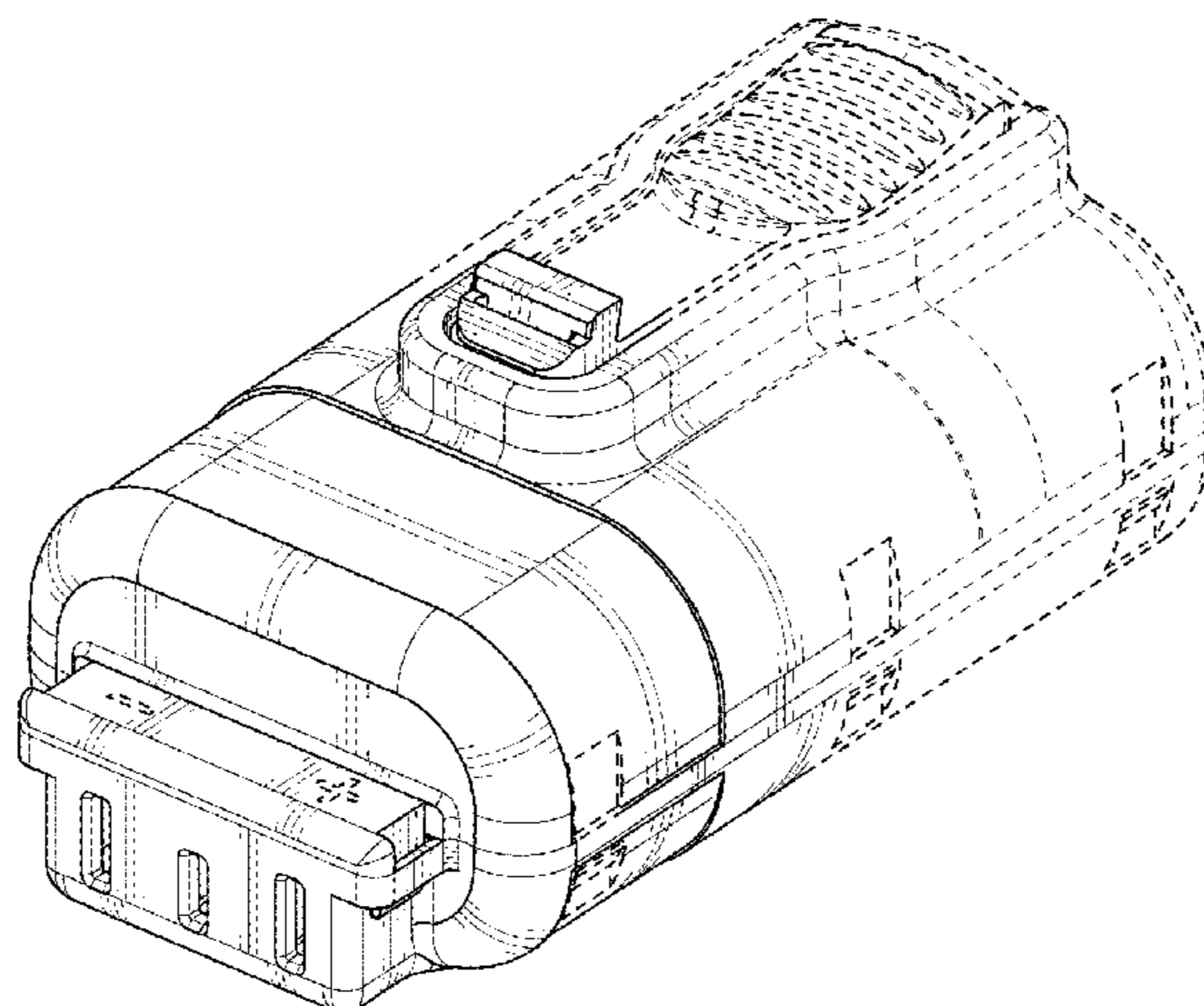

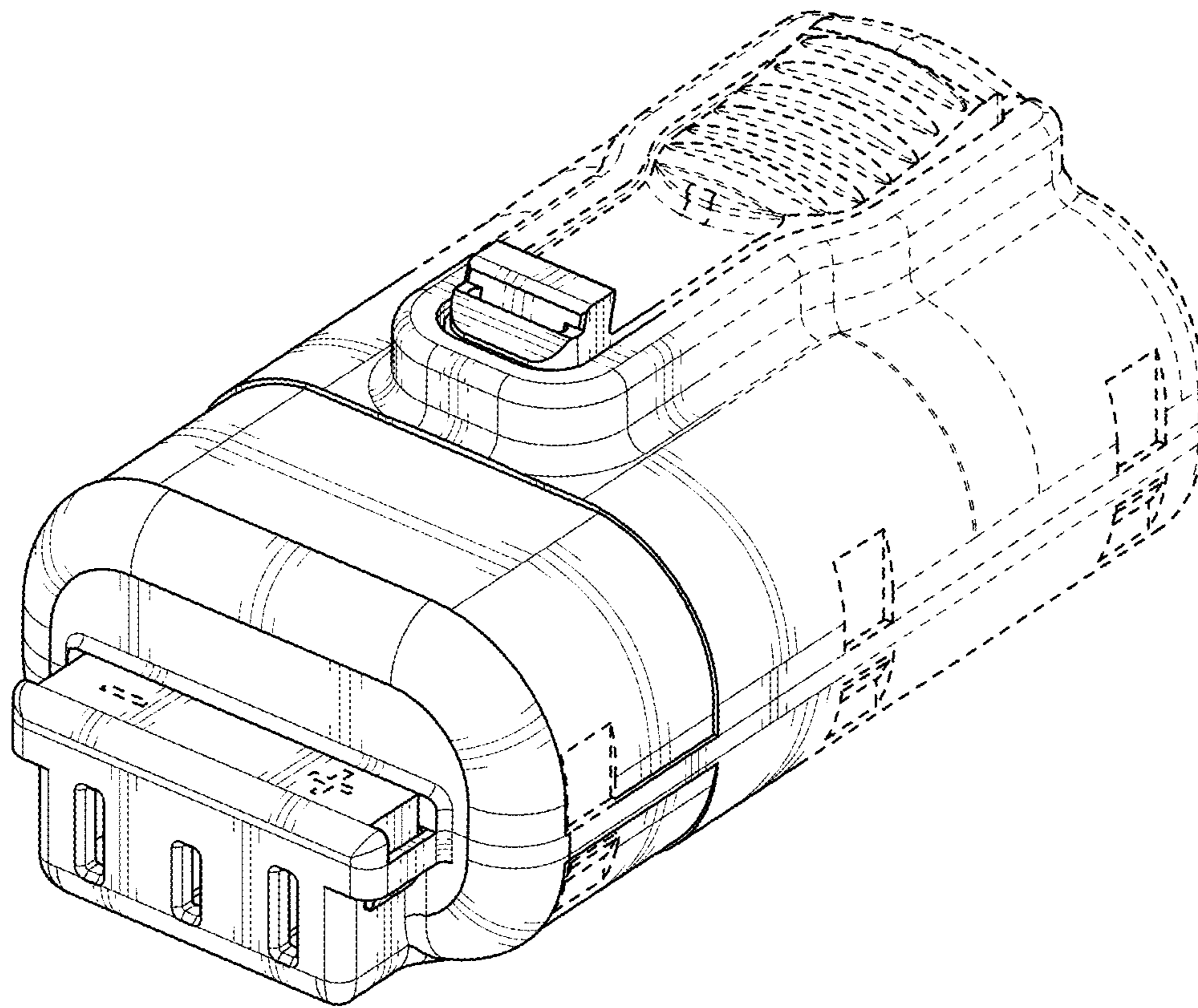

FIG. 1

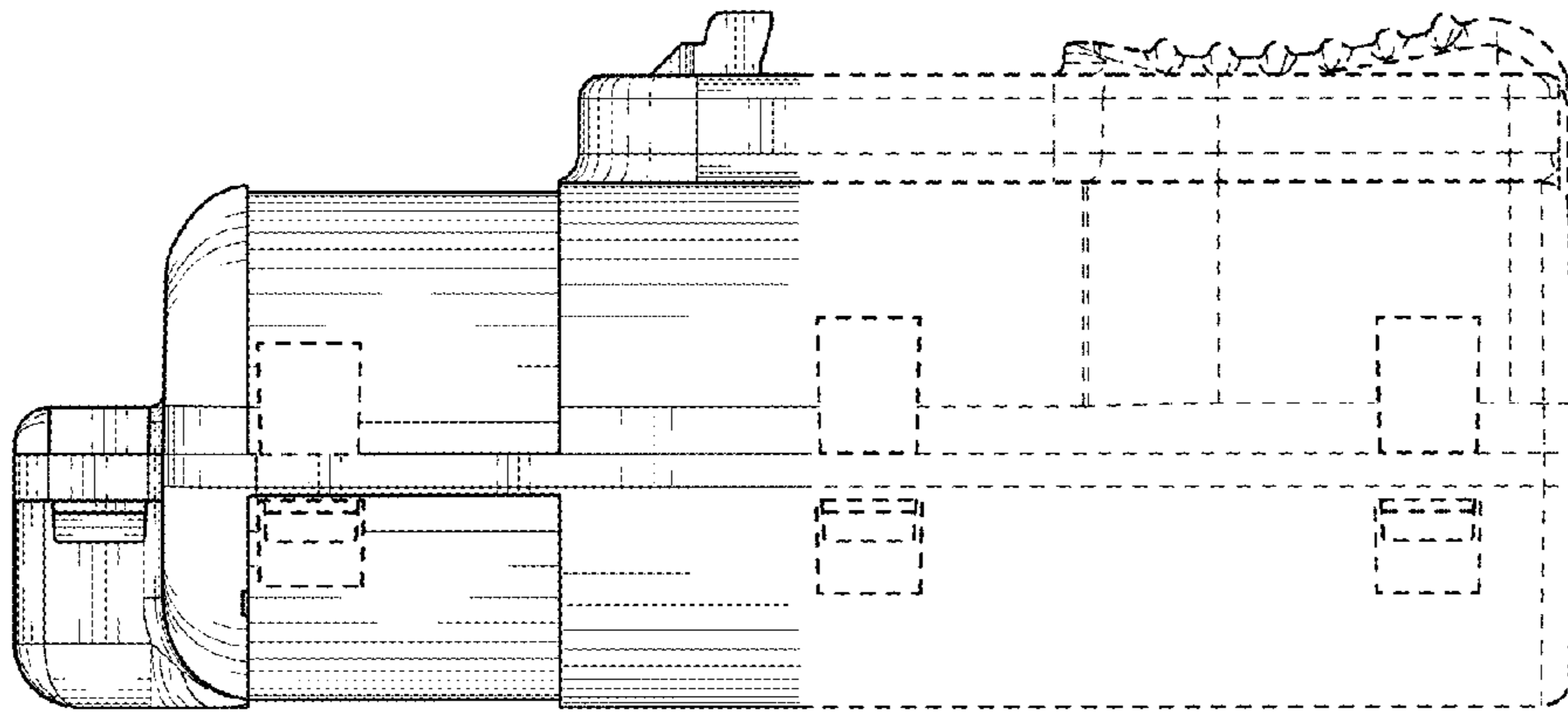

FIG. 2

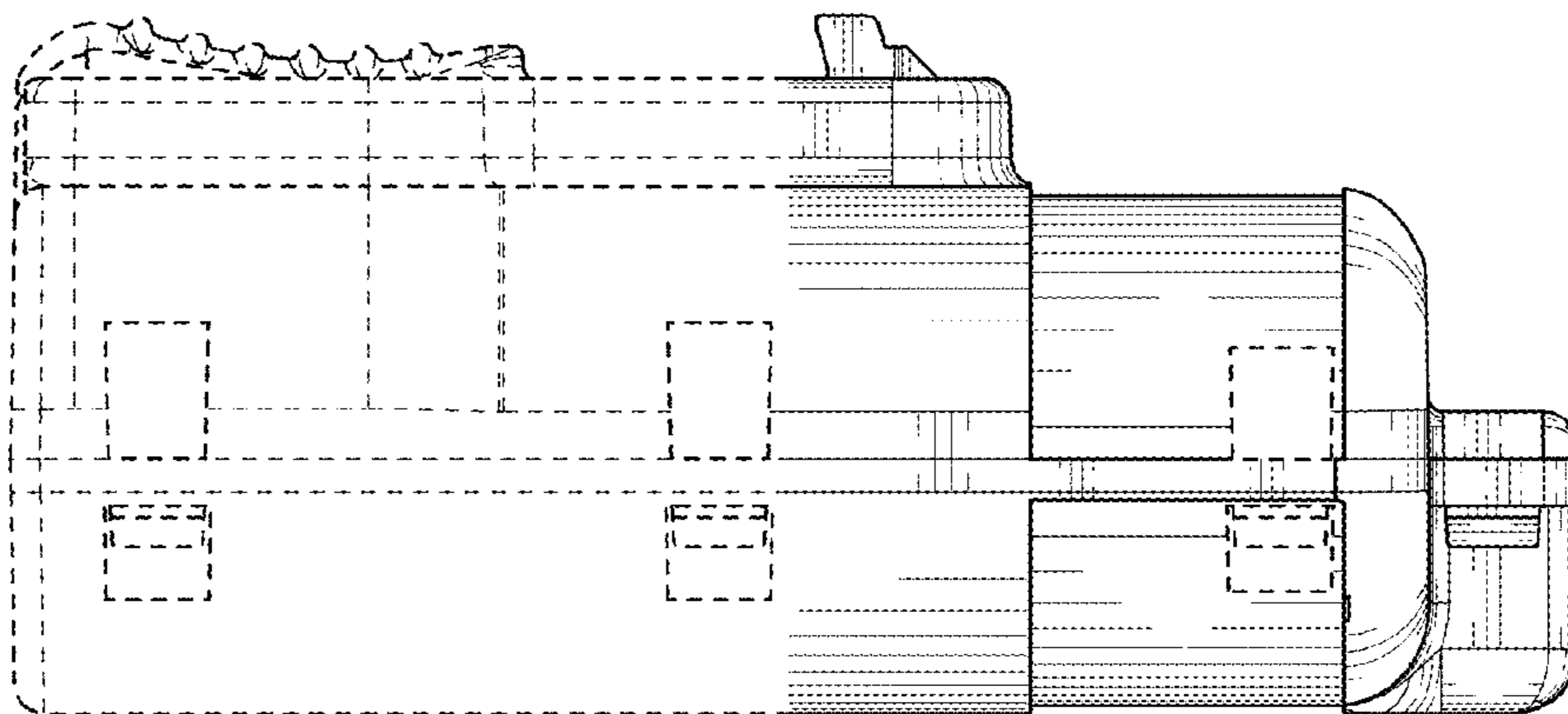

FIG. 3

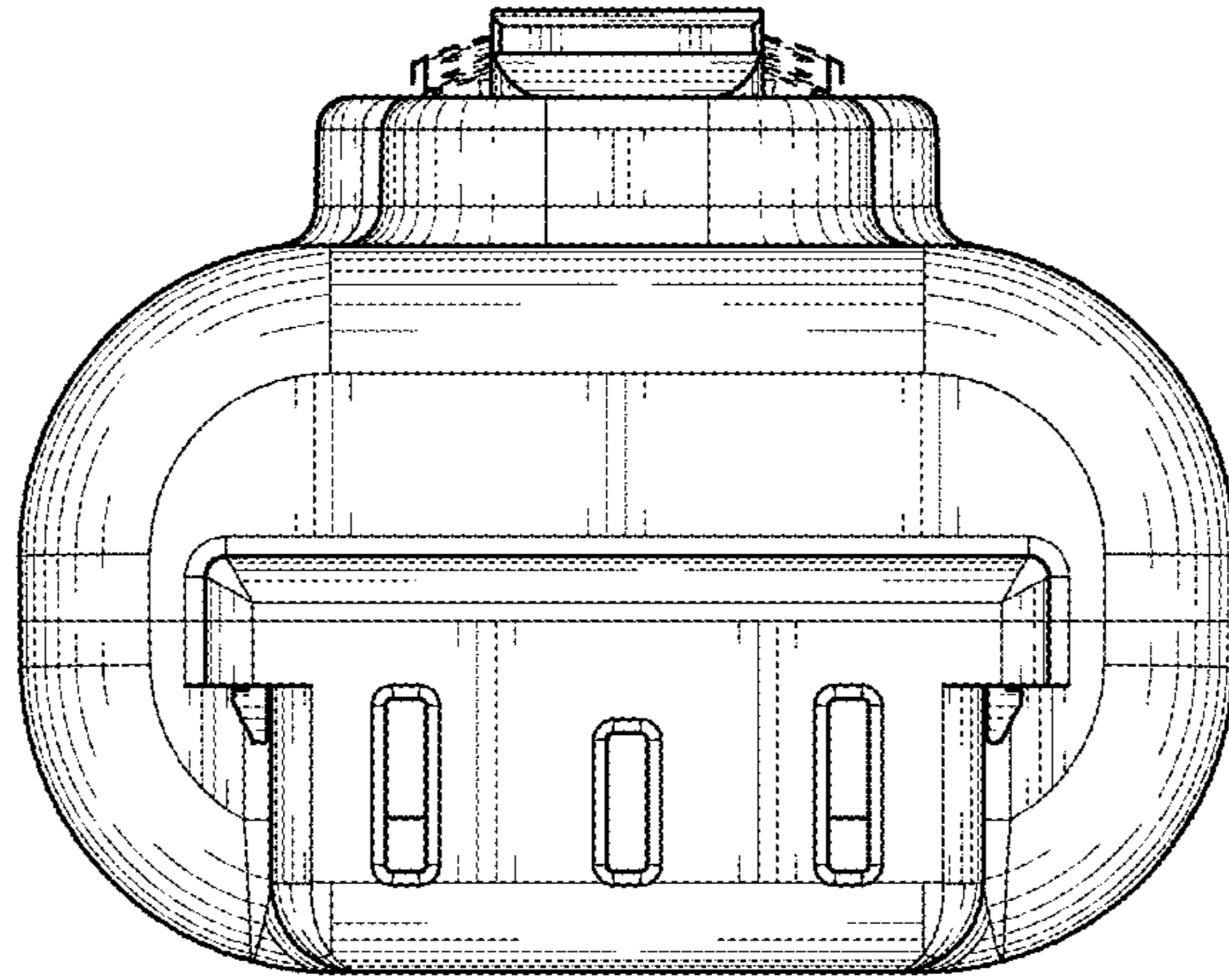

FIG. 4

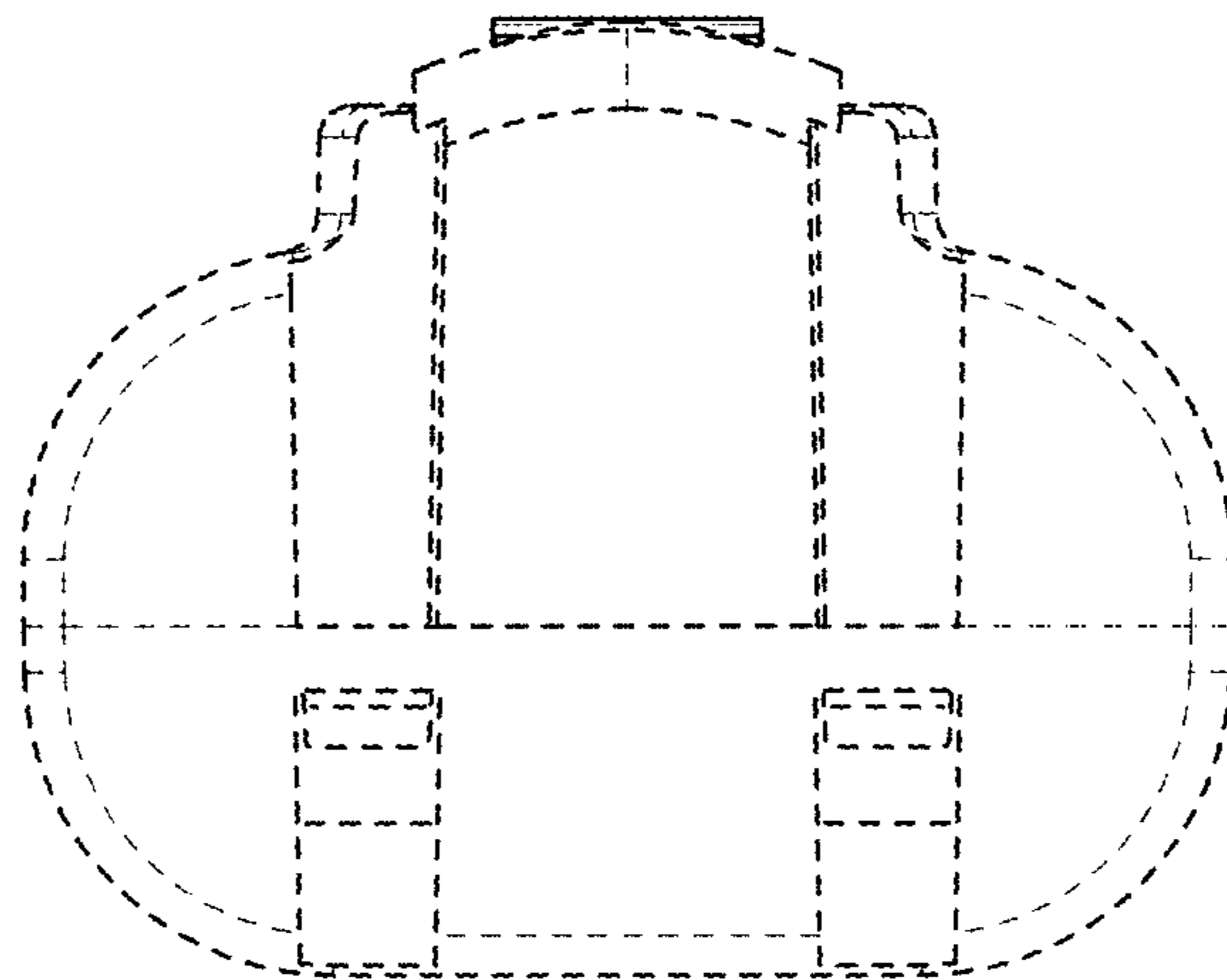

FIG. 5



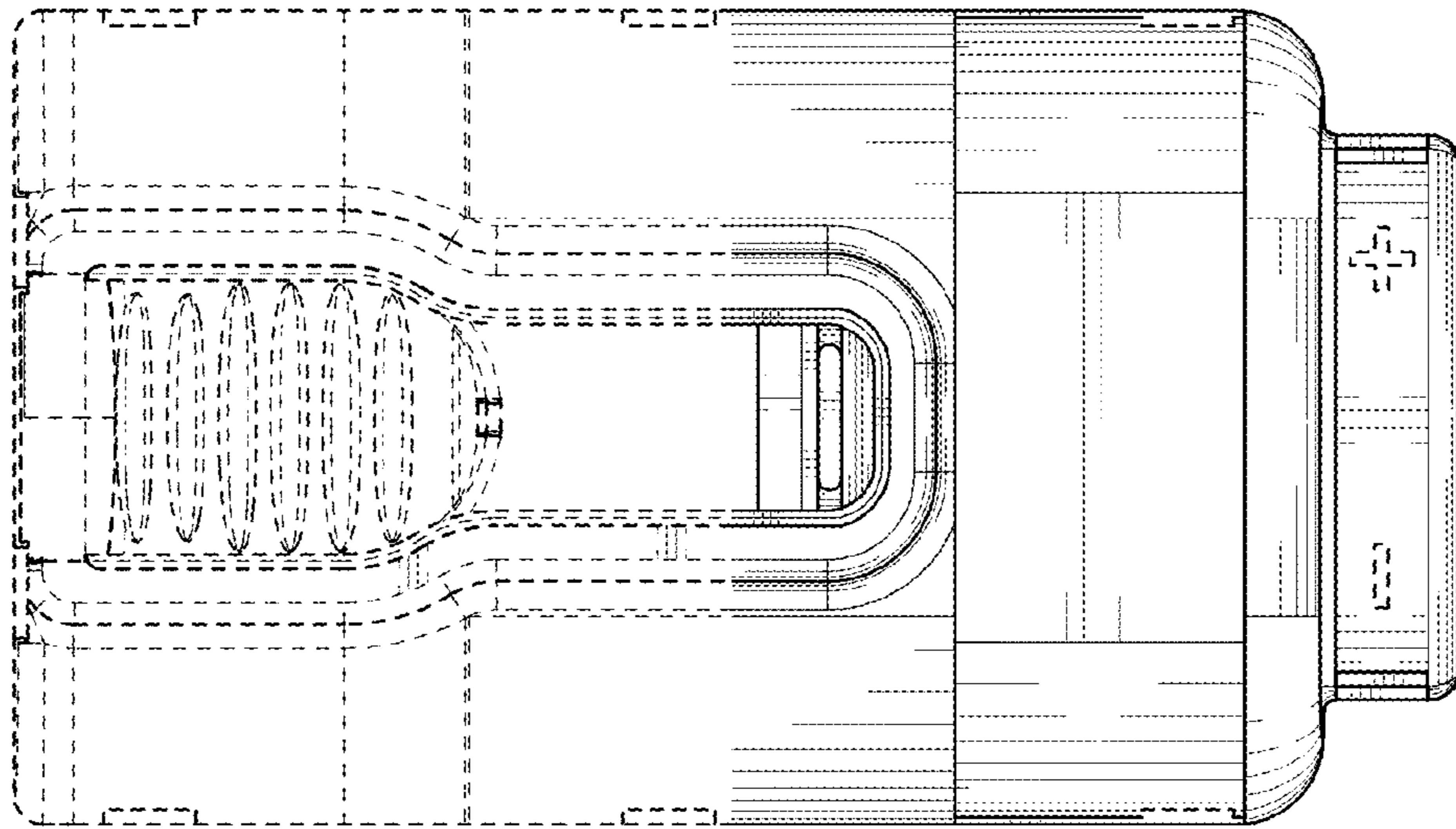

FIG. 6

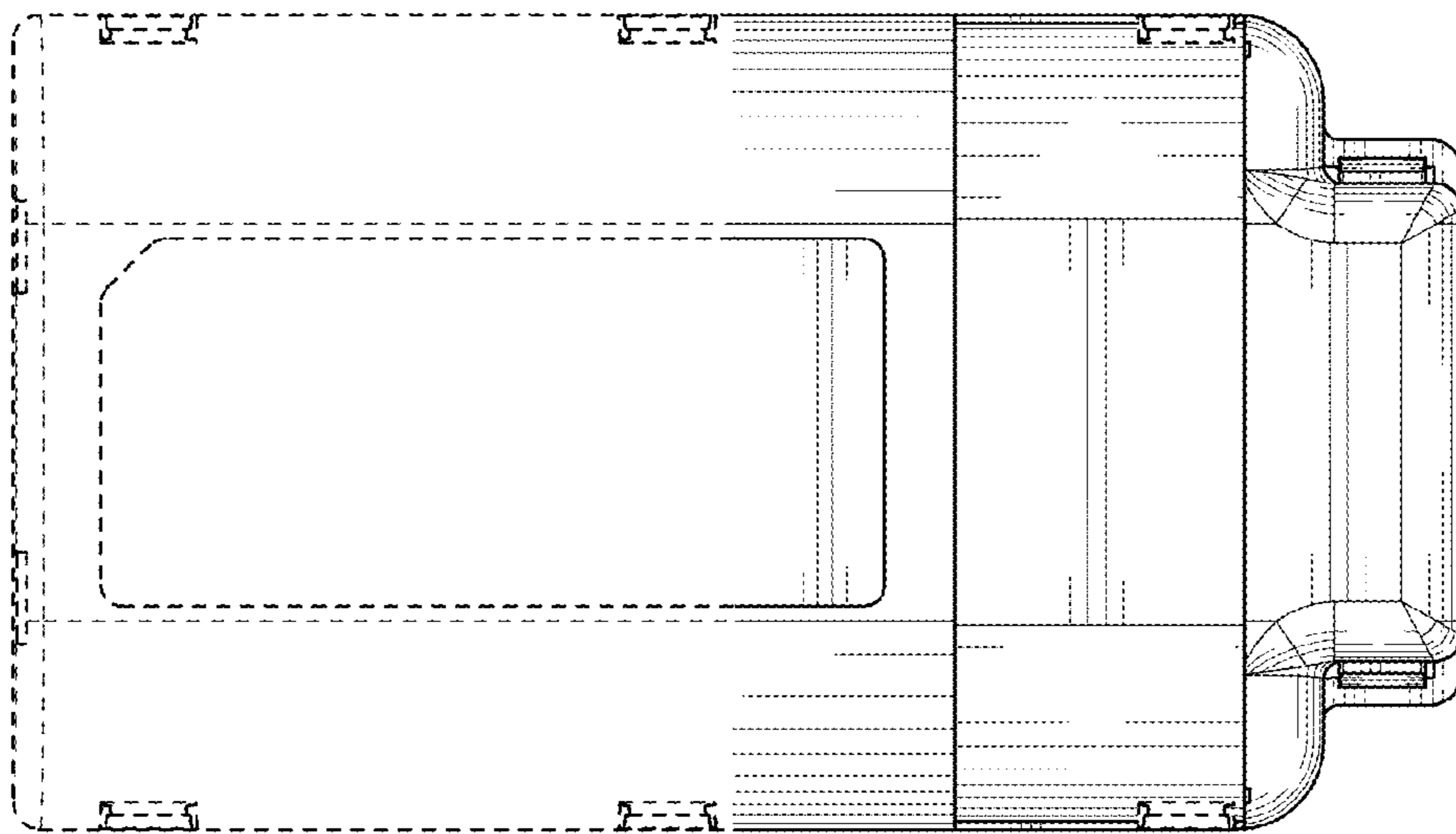

FIG. 7