



US00D698154S

(12) **United States Design Patent**
Ford

(10) **Patent No.:** **US D698,154 S**
(45) **Date of Patent:** **** Jan. 28, 2014**

(54) **HANDBAG WITH CLASP**

(71) Applicant: **Thomas C. Ford**, Los Angeles, CA (US)

(72) Inventor: **Thomas C. Ford**, Los Angeles, CA (US)

(73) Assignee: **Thomas C. Ford**, Los Angeles, CA (US)

(**) Term: **14 Years**

(21) Appl. No.: **29/444,561**

(22) Filed: **Jan. 31, 2013**

(51) **LOC (10) Cl.** **03-01**

(52) **U.S. Cl.**
USPC **D3/318**

(58) **Field of Classification Search**
USPC D3/232-233, 240-243, 245-246, 318;
150/100, 103-110, 113-114, 117-119
See application file for complete search history.

(56) **References Cited**

U.S. PATENT DOCUMENTS

2,026,663	A *	1/1936	Wunthal	150/113
2,034,398	A *	3/1936	Kash	150/117
D154,329	S *	6/1949	Schiff	D3/233
D351,062	S *	10/1994	Shapland et al.	D3/233
D632,889	S *	2/2011	Jobert	D3/243
D655,583	S *	3/2012	Palazzolo	D7/709

* cited by examiner

Primary Examiner — Holly Baynham

(74) *Attorney, Agent, or Firm* — Goodwin Procter LLP

(57) **CLAIM**

The ornamental design for a handbag with clasp, as shown and described.

DESCRIPTION

FIG. 1 is a front perspective view of a handbag with clasp in a first position;

FIG. 2 is a front view of the handbag with clasp in the first position;

FIG. 3 is a front view of the handbag with clasp in a second position;

FIG. 4 is a left side view of the handbag with clasp in the first position;

FIG. 5 is a right side view of the handbag with clasp in the first position;

FIG. 6 is a top view of the handbag with clasp in the first position;

FIG. 7 is a bottom view of the handbag with clasp in the first position; and,

FIG. 8 is a rear view of the handbag with clasp.

The broken lines showing a handbag are for the purposes of illustrating environment and form no part of the claimed design.

1 Claim, 6 Drawing Sheets

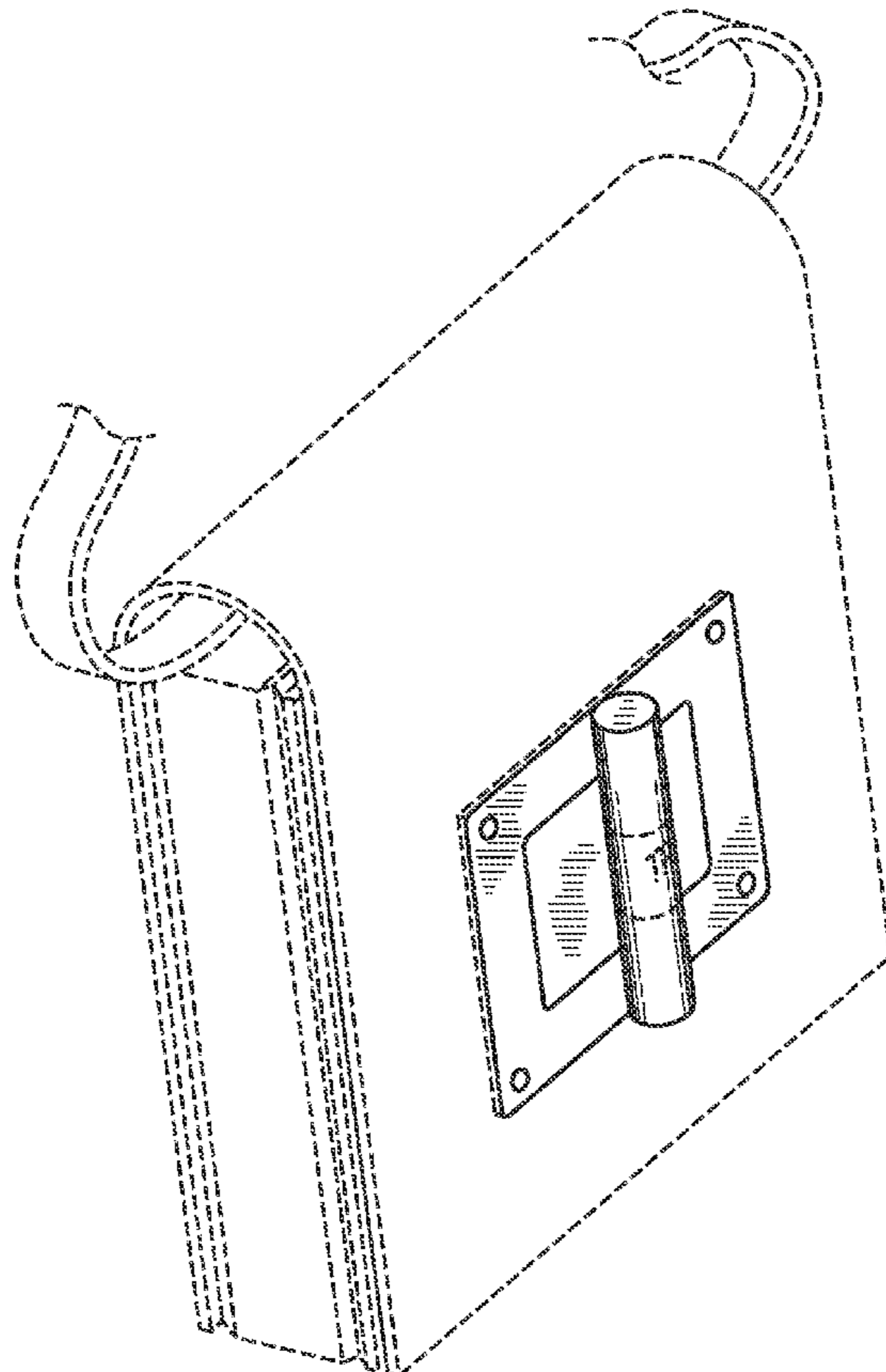

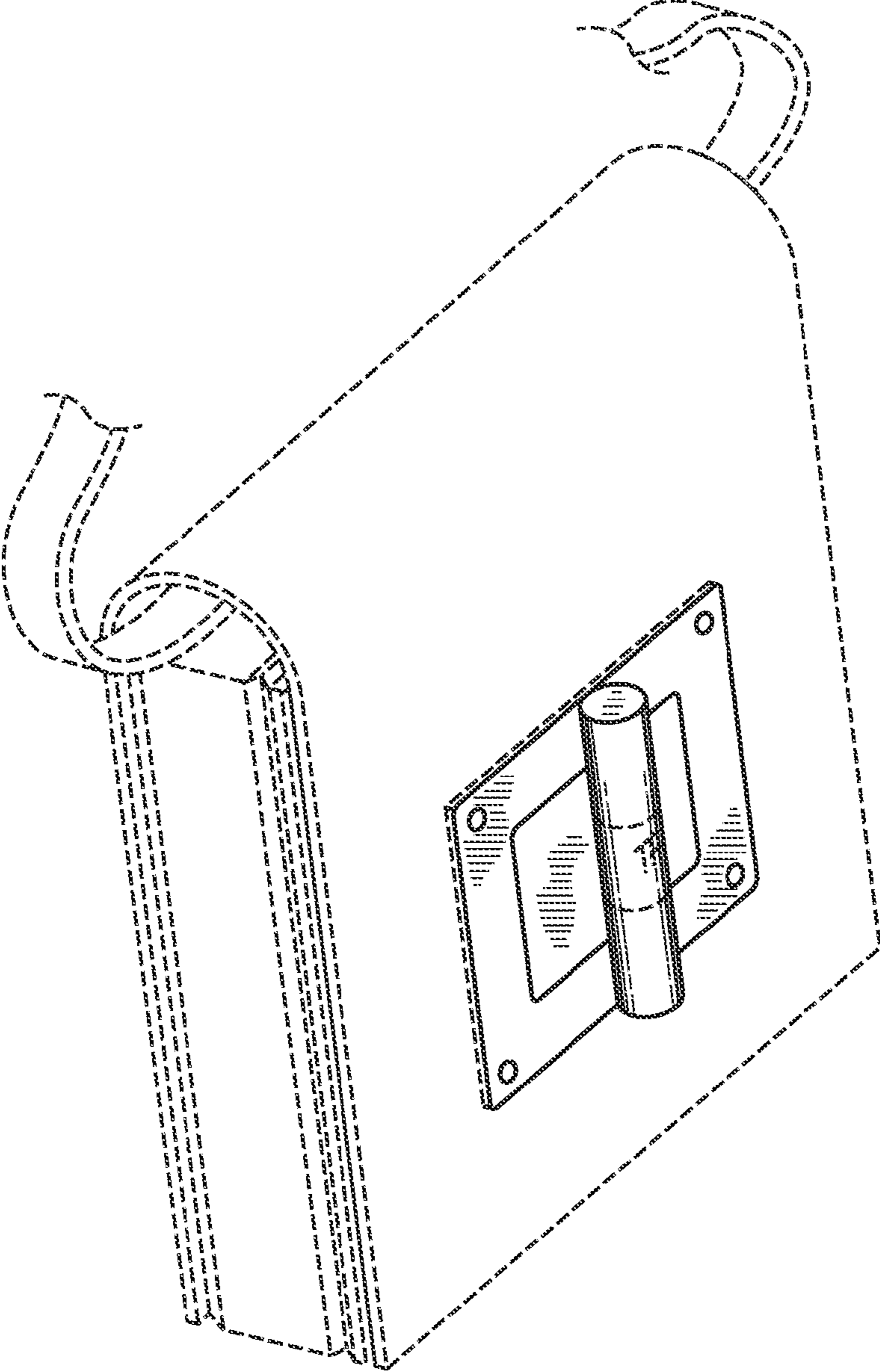

FIG. 1

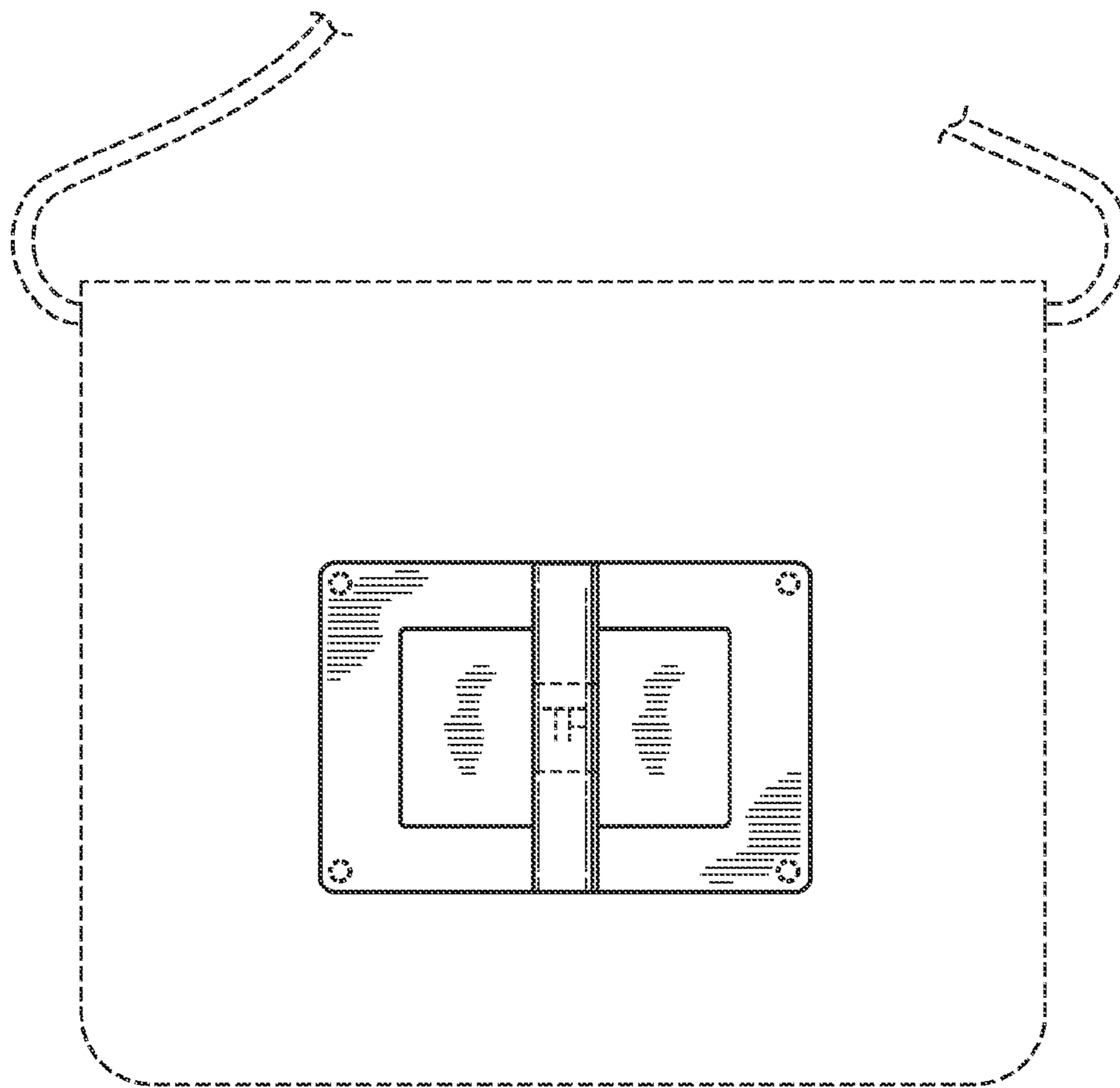

FIG. 2

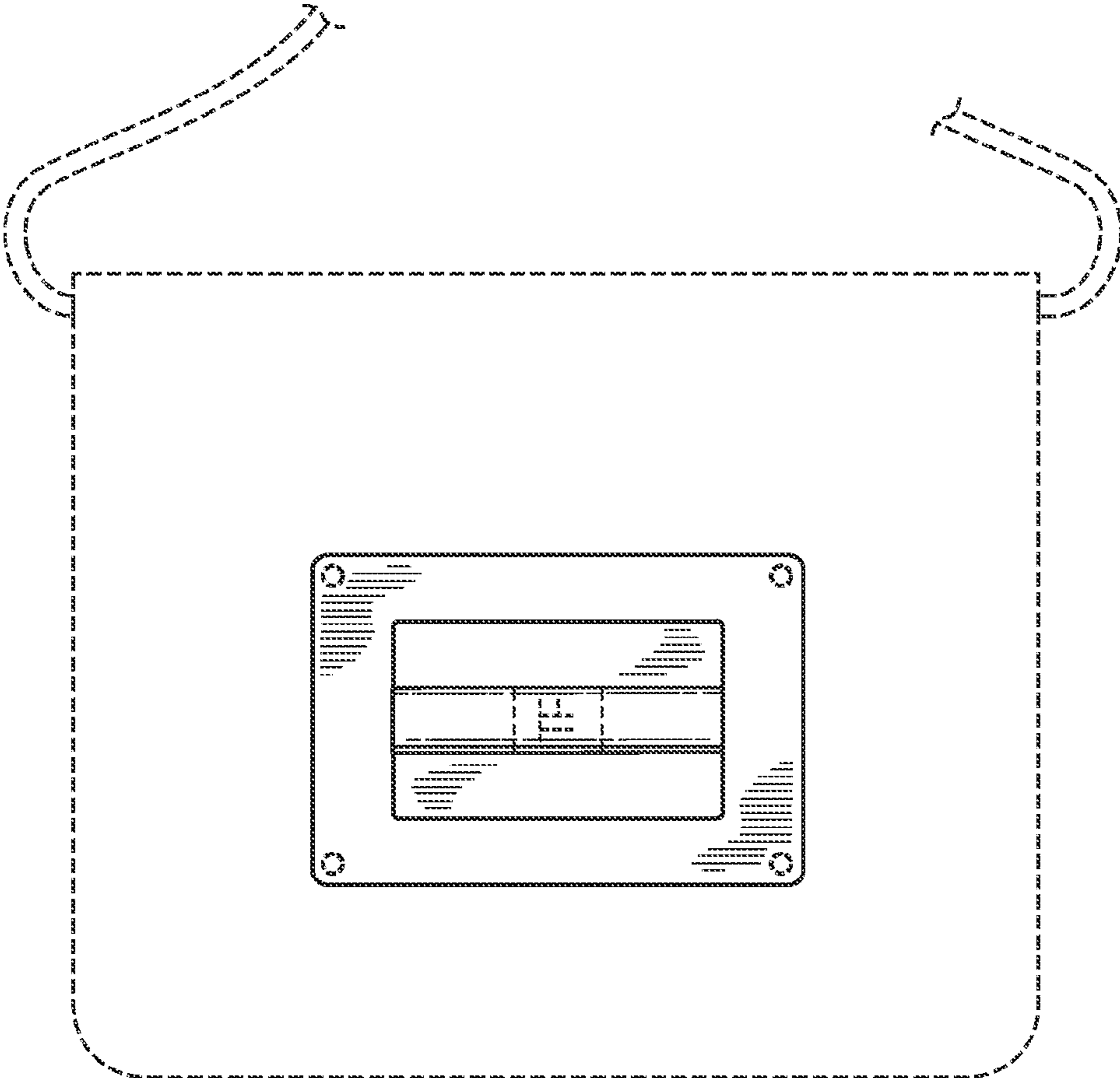

FIG. 3

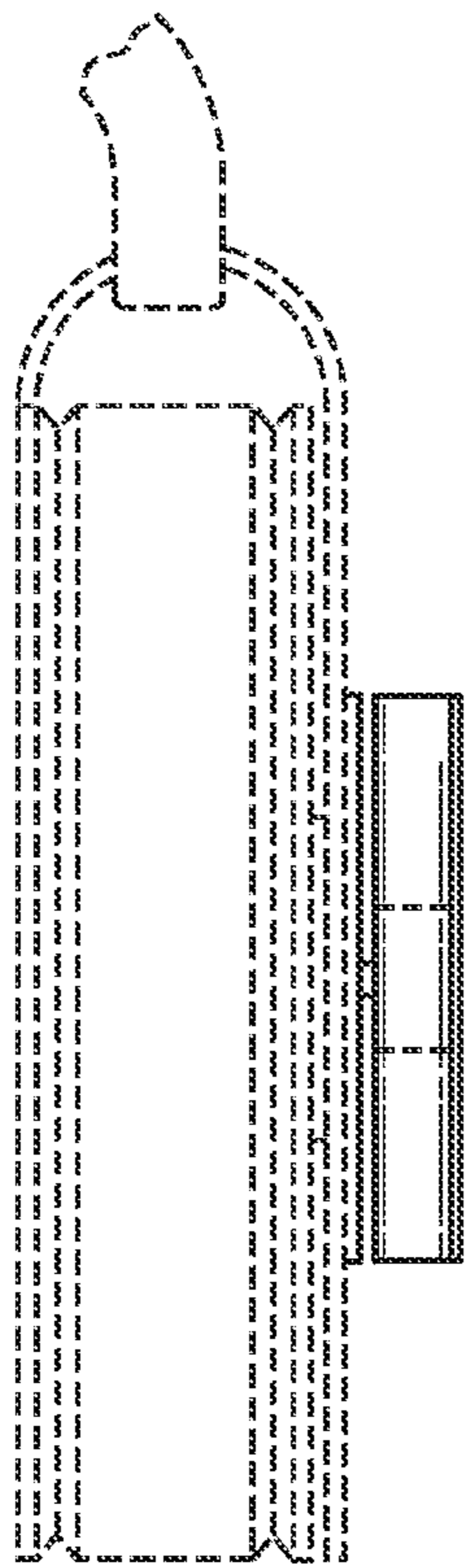

FIG. 4

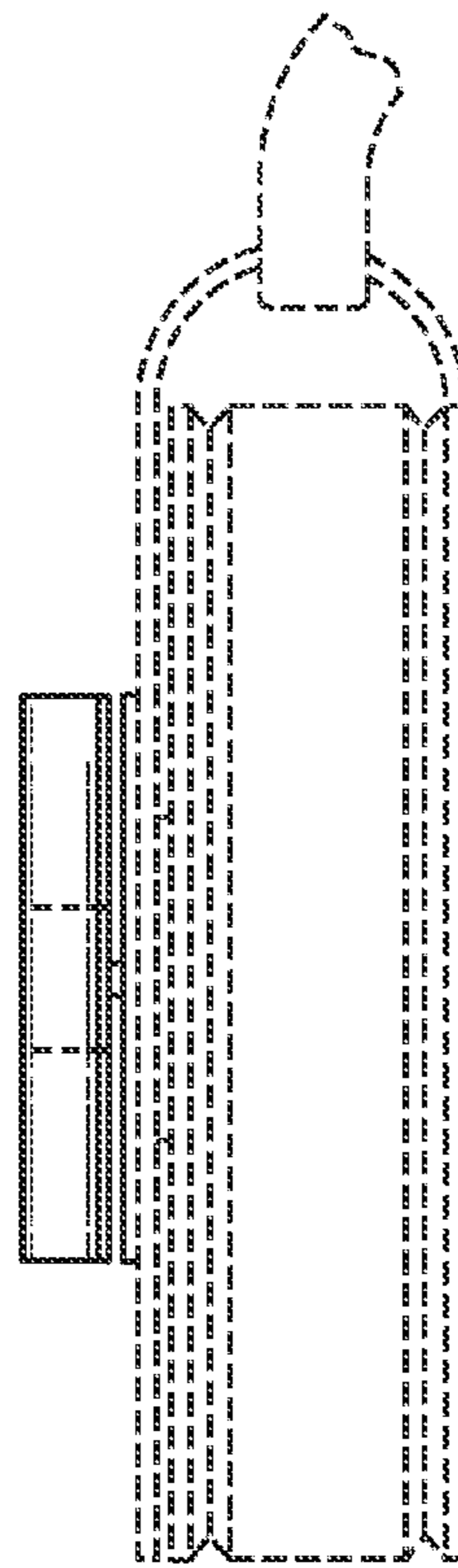

FIG. 5

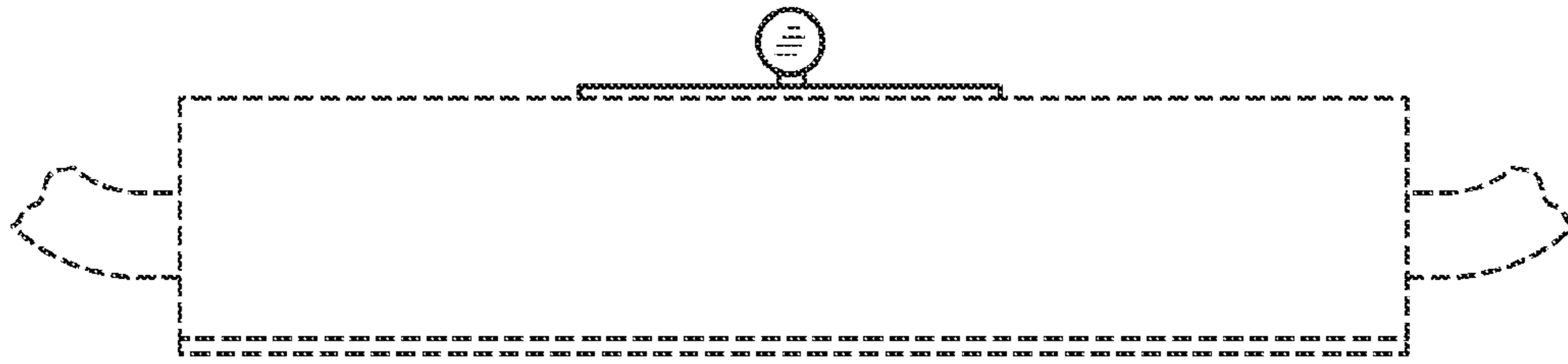

FIG. 6

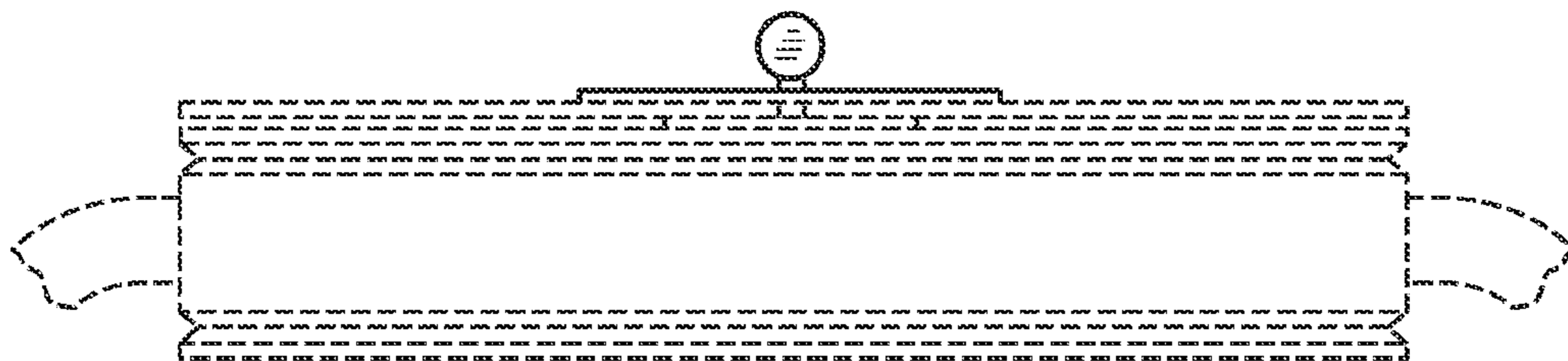

FIG. 7

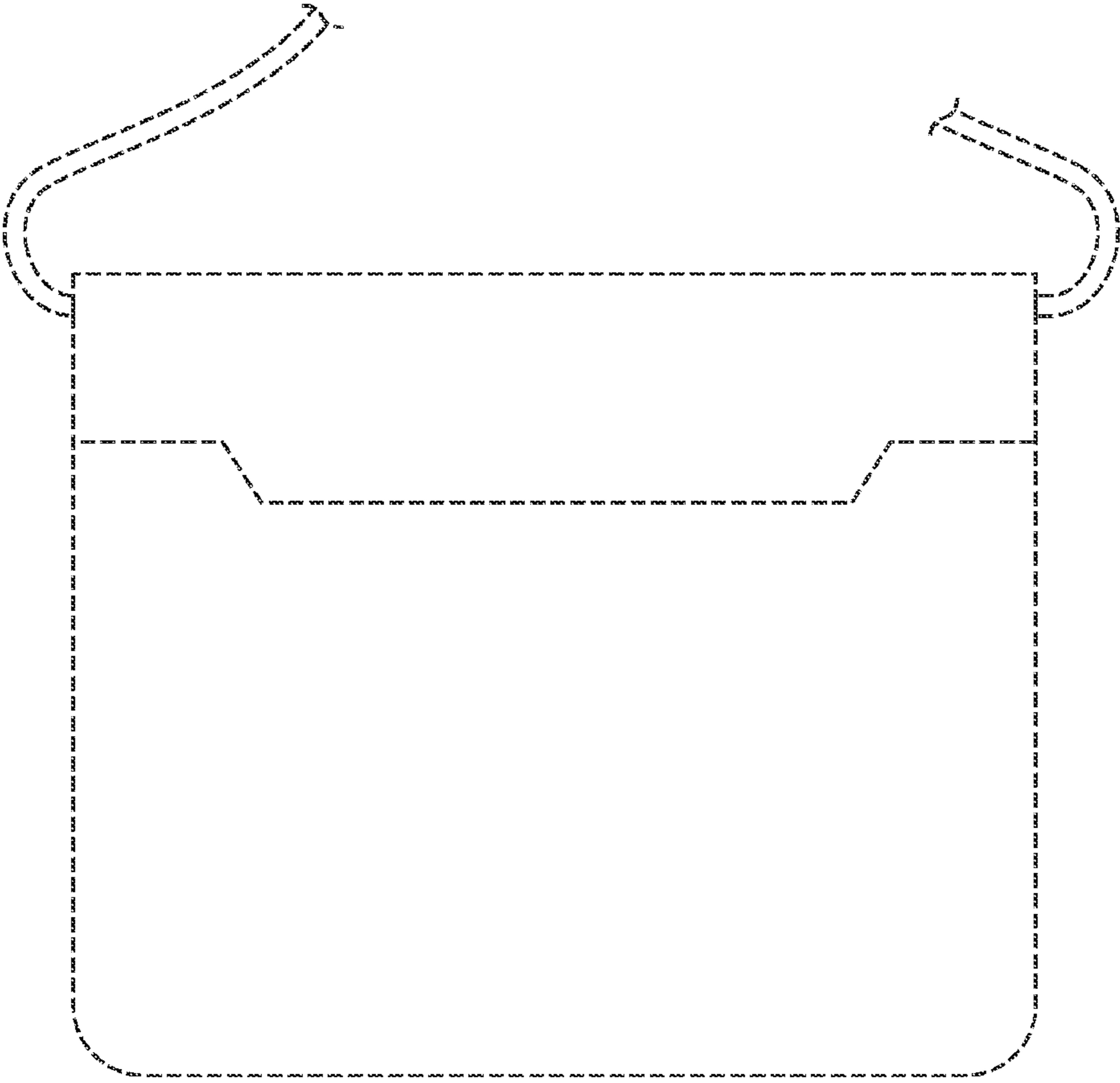

FIG. 8

UNITED STATES PATENT AND TRADEMARK OFFICE
CERTIFICATE OF CORRECTION

PATENT NO. : D698,154 S
APPLICATION NO. : 29/444561
DATED : January 28, 2014
INVENTOR(S) : Ford

Page 1 of 1

It is certified that error appears in the above-identified patent and that said Letters Patent is hereby corrected as shown below:

On the Title Page: Assignee:

“Thomas C. Ford, Los Angeles, CA (US)” should be deleted as Assignee under item 73.

Signed and Sealed this
Twenty-fourth Day of June, 2014



Michelle K. Lee
Deputy Director of the United States Patent and Trademark Office