



US00D697960S

(12) **United States Design Patent**
Sato

(10) **Patent No.:** **US D697,960 S**
(45) **Date of Patent:** **** Jan. 21, 2014**

(54) **CAMERA BODY**

D635,605 S * 4/2011 Katayama D16/202
D669,927 S * 10/2012 Akita D16/200

(75) Inventor: **Jun Sato**, Saitama (JP)

* cited by examiner

(73) Assignee: **FUJIFILM Corporation**, Tokyo (JP)

Primary Examiner — Adir Aronovich

(**) Term: **14 Years**

(74) *Attorney, Agent, or Firm* — Sughrue Mion, PLLC

(21) Appl. No.: **29/426,352**

(57) **CLAIM**

The ornamental design for a camera body, as shown and described.

(22) Filed: **Jul. 3, 2012**

DESCRIPTION

(30) **Foreign Application Priority Data**

Jan. 6, 2012 (JP) 2012-000168

(51) **LOC (10) Cl.** **16-05**

(52) **U.S. Cl.**
USPC **D16/219; D16/200**

(58) **Field of Classification Search**
USPC D16/200, 202, 204, 218, 219;
348/373-376; 358/909.1; 396/535, 540
See application file for complete search history.

FIG. 1 is a top, front and left side perspective view of a camera body showing my new design;
FIG. 2 is a front elevational view thereof;
FIG. 3 is a rear elevational view thereof;
FIG. 4 is a top plan view thereof;
FIG. 5 is a bottom plan view thereof;
FIG. 6 is a right side elevational view thereof;
FIG. 7 is a left side elevational view thereof; and,
FIG. 8 is a top, front and left side perspective view thereof in a manner of use.

(56) **References Cited**

U.S. PATENT DOCUMENTS

D400,901 S * 11/1998 Chapman et al. D16/219
D423,545 S * 4/2000 Schelling et al. D16/219
D508,254 S * 8/2005 Fujii D16/219

The portions of the camera body in broken lines are shown for illustrative purposes only and form no part of the claimed design.

The dash-dot broken lines in the drawings which define the bounds of the claimed design form no part thereof.

1 Claim, 7 Drawing Sheets

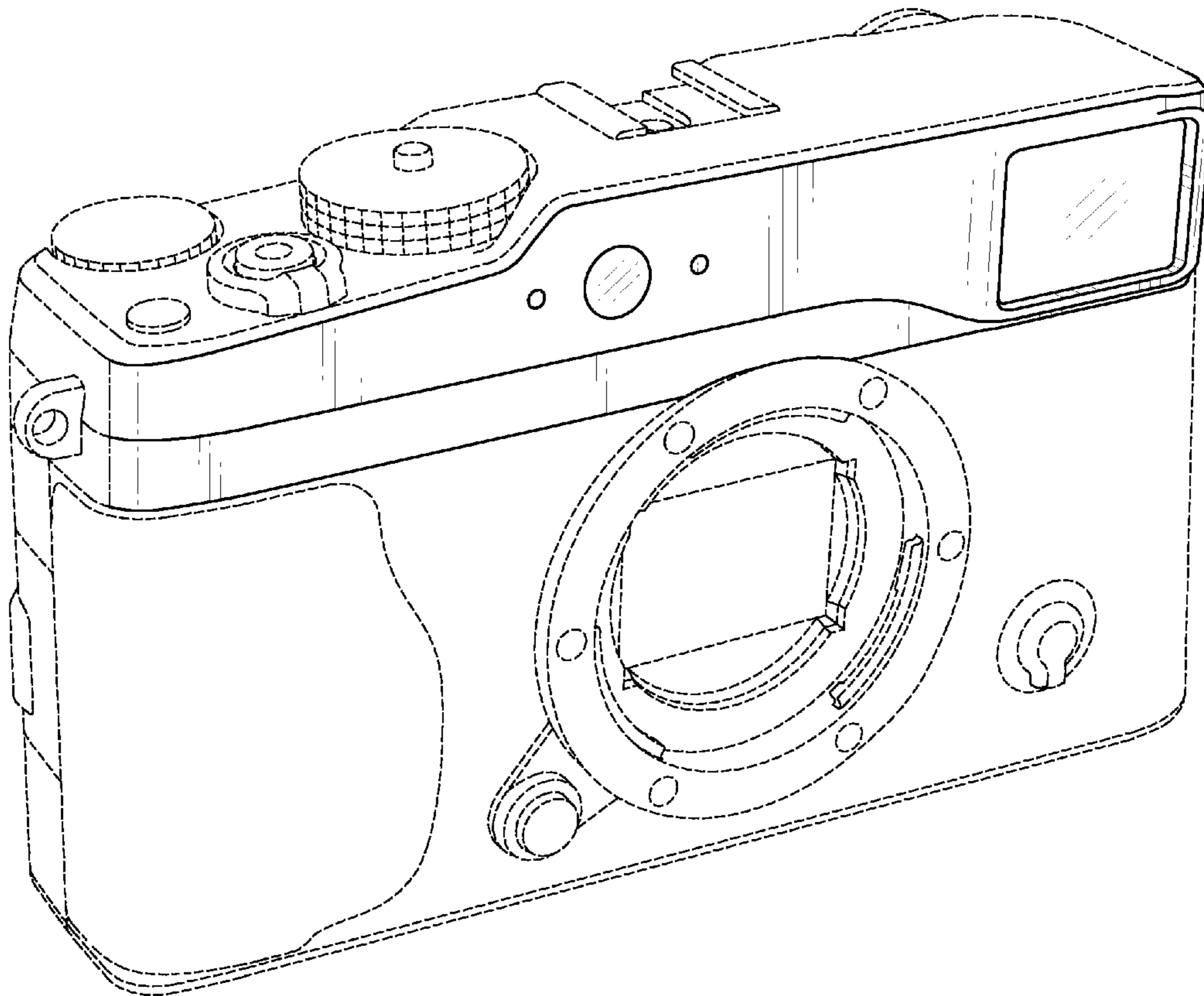

FIG.1

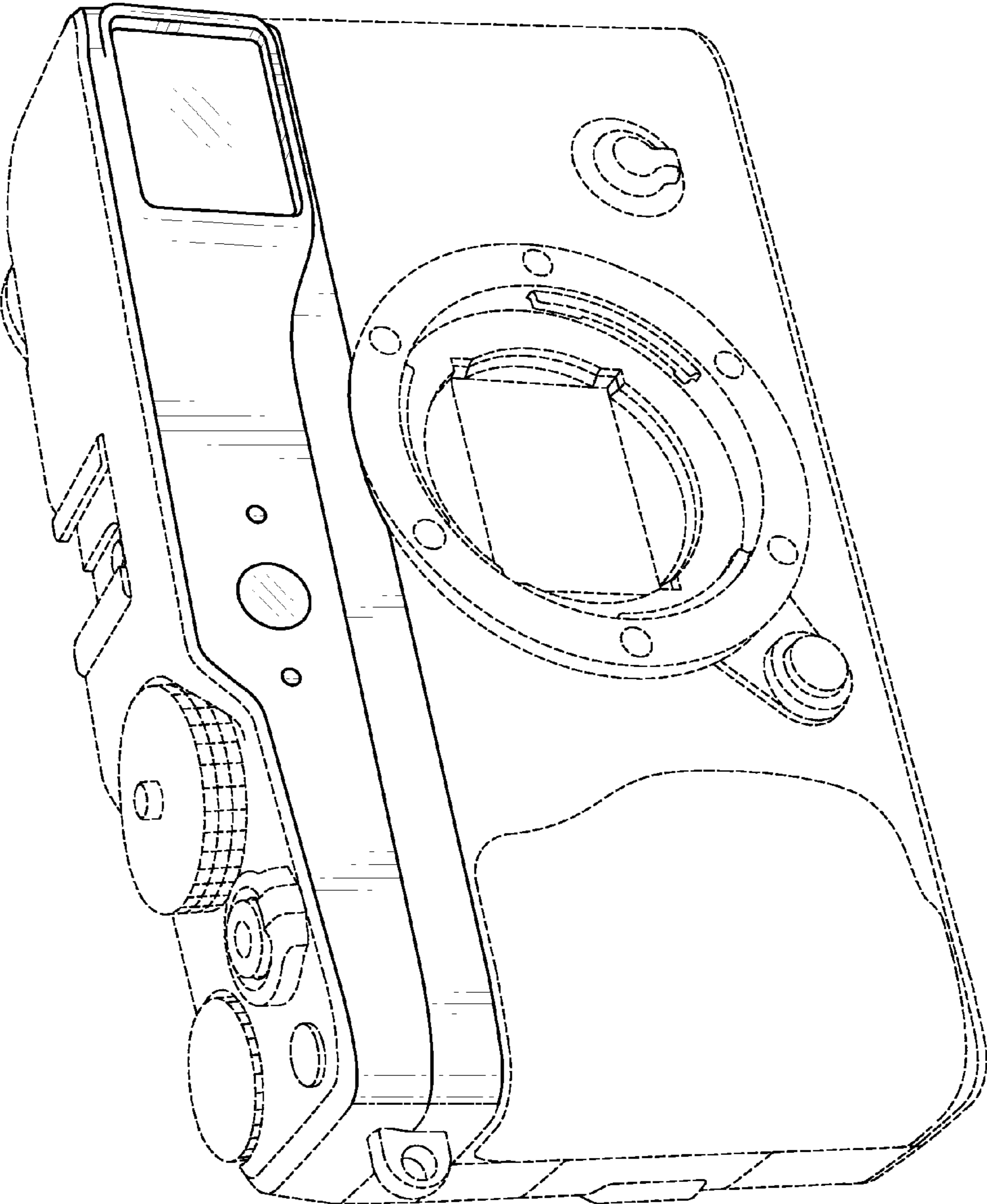

FIG.2

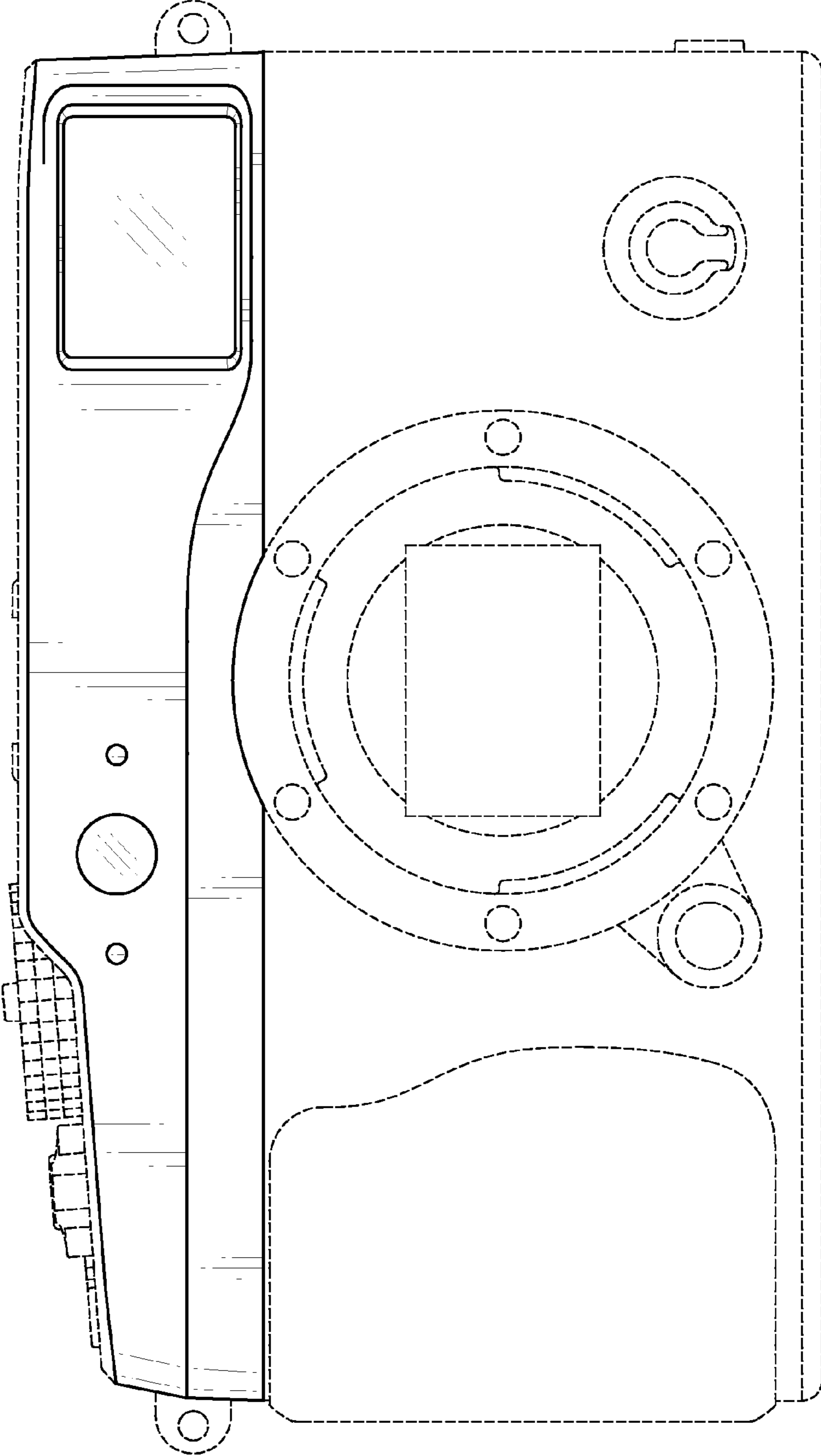

FIG. 3

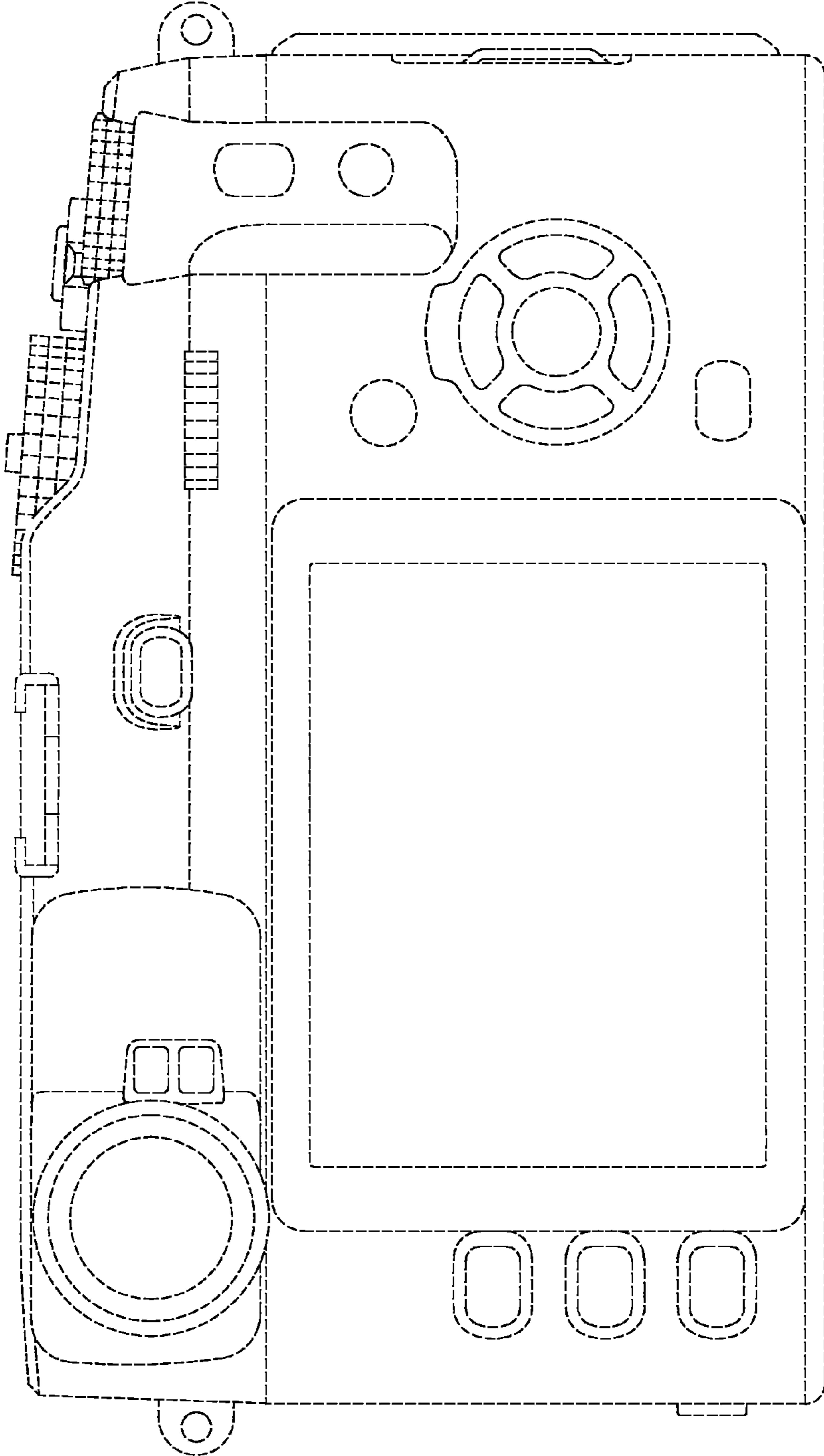

FIG.4

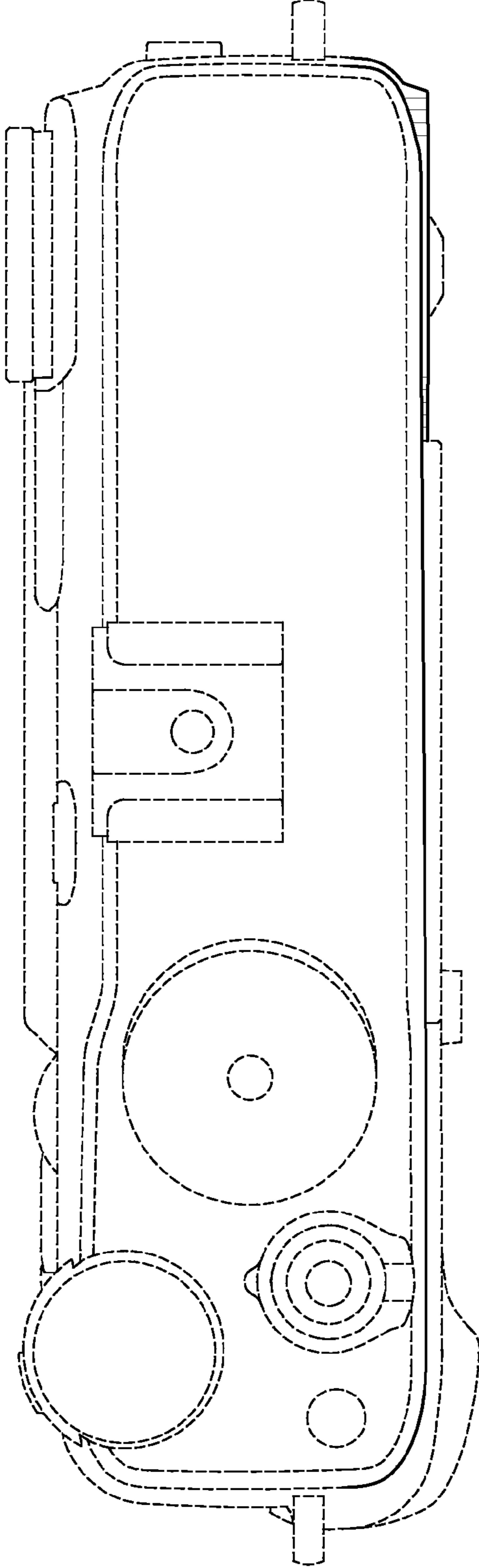

FIG. 5

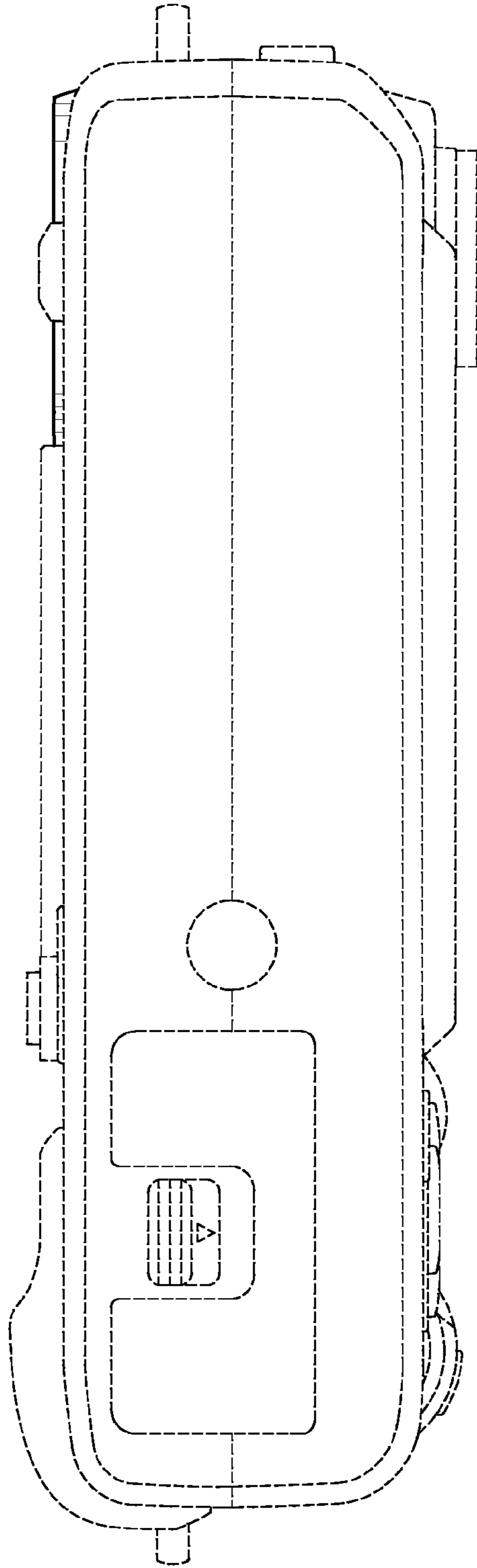

FIG. 7

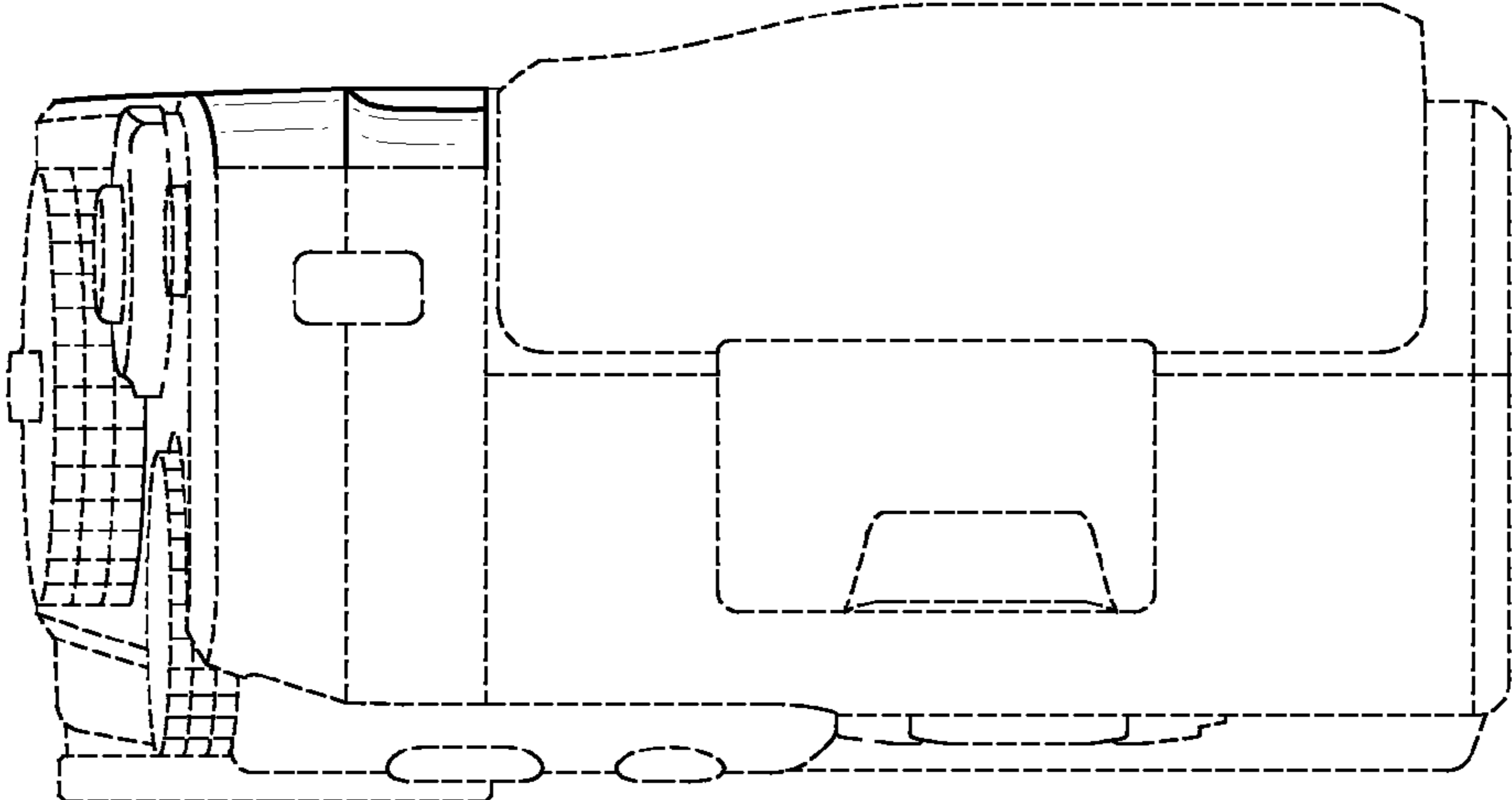

FIG. 6

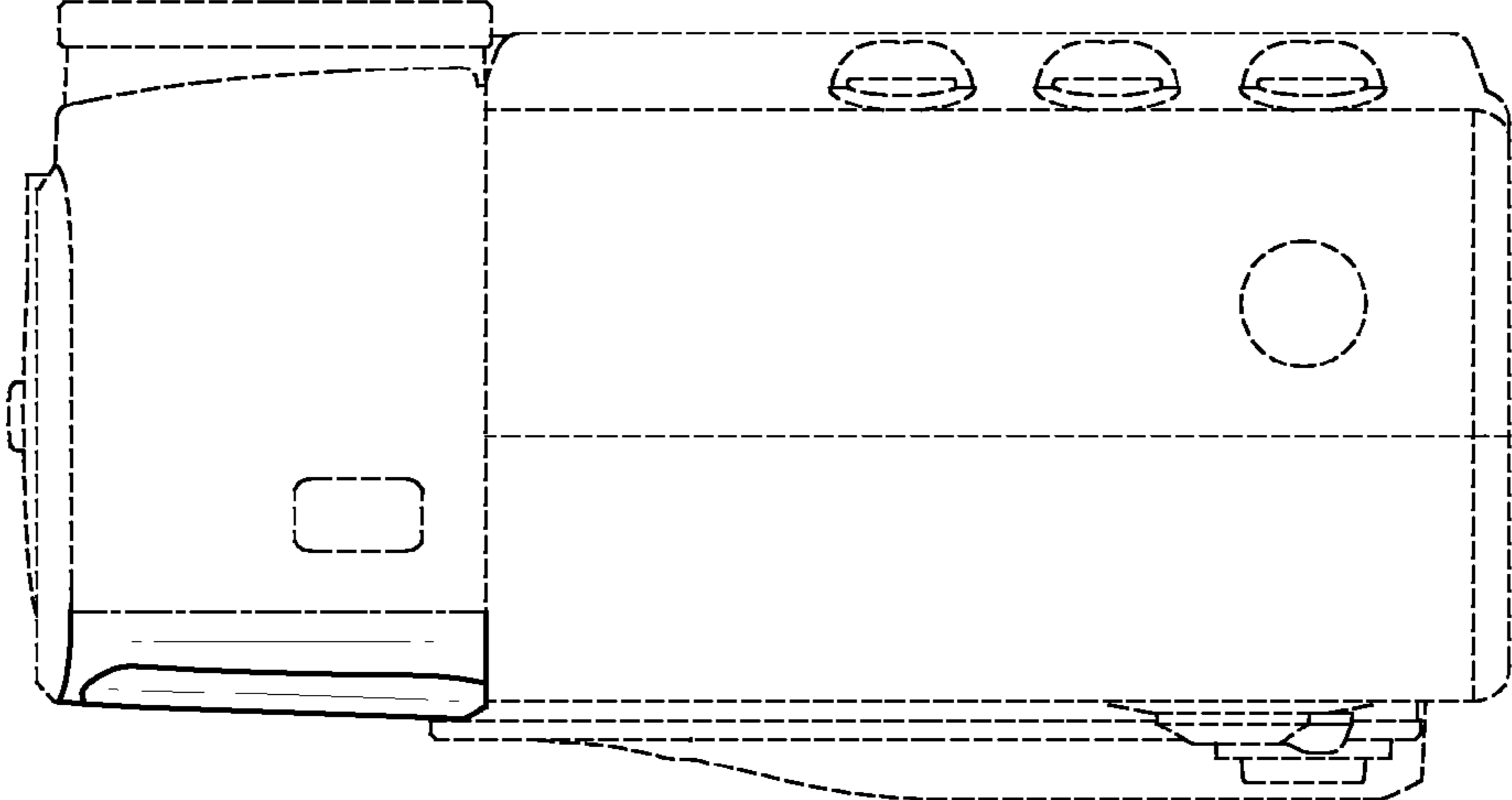

FIG.8

