



US00D697634S

(12) **United States Design Patent**
Aston et al.

(10) **Patent No.:** **US D697,634 S**
(45) **Date of Patent:** **** *Jan. 14, 2014**

(54) **UPPER PORTION OF A CONCRETE BRIDGE UNIT**

(75) Inventors: **Scott D. Aston**, Liberty Township, OH (US); **Michael G. Carfagno**, Centerville, OH (US); **Philip A. Creamer**, Springboro, OH (US)

(73) Assignee: **Contech Engineered Solutions LLC**, West Chester, OH (US)

(*) Notice: This patent is subject to a terminal disclaimer.

(**) Term: **14 Years**

(21) Appl. No.: **29/413,755**

(22) Filed: **Feb. 20, 2012**

(51) **LOC (10) Cl.** **25-03**

(52) **U.S. Cl.**
USPC **D25/1**

(58) **Field of Classification Search**
USPC D25/102, 35; 14/2, 24, 25, 26; 405/134, 405/124, 126
See application file for complete search history.

(56) **References Cited**

U.S. PATENT DOCUMENTS

109,886 A	12/1870	Freeman
567,653 A	9/1896	Parker
1,074,268 A	9/1913	Kelly et al.
1,184,634 A	5/1916	Duerswachter
1,219,434 A	3/1917	Burkholder
1,474,808 A	11/1923	Zucco
1,784,271 A	12/1930	Collins
2,616,149 A	11/1952	Waller
3,195,852 A	7/1965	Lundell
3,286,972 A	11/1966	Jackson
3,397,494 A	8/1968	Waring
3,848,377 A	11/1974	Mori
4,094,110 A	6/1978	Dicken et al.
4,099,360 A	7/1978	Outram
4,141,666 A	2/1979	DeGraff
4,211,504 A	7/1980	Sivachenko
4,314,775 A	2/1982	Johnson

4,318,635 A	3/1982	Gurtner et al.
4,558,969 A	12/1985	FitzSimons
4,563,107 A	1/1986	Peterson
4,587,684 A	5/1986	Miller
4,687,371 A	8/1987	Lockwood
4,693,634 A	9/1987	Chiaves
4,723,871 A	2/1988	Roscoe
4,797,030 A	1/1989	Lockwood
4,817,353 A	4/1989	Woods et al.
4,854,775 A	8/1989	Lockwood
4,972,641 A	11/1990	Barrios
4,972,646 A	11/1990	Miller et al.
4,987,707 A	1/1991	Kiselev et al.
4,993,872 A	2/1991	Lockwood
5,252,002 A	10/1993	Day
5,326,191 A	7/1994	Wilson et al.
5,505,033 A	4/1996	Matsuo et al.
5,524,405 A	6/1996	Byrd
5,533,835 A	7/1996	Angelette
5,536,113 A	7/1996	McGregor
5,586,417 A	12/1996	Hendersjon et al.
5,720,577 A	2/1998	Sanders et al.
5,836,717 A	11/1998	Bernini
D406,902 S	3/1999	Lockwood
D426,321 S	6/2000	Lockwood
6,094,881 A	8/2000	Lockwood
6,129,484 A	10/2000	Chiaves
6,161,342 A	12/2000	Barbier et al.
6,205,717 B1	3/2001	Shall et al.
6,243,994 B1	6/2001	Bernini
6,367,214 B1	4/2002	Monachino
6,408,581 B2	6/2002	Monachino
6,474,907 B2	11/2002	Semotiuk et al.
6,640,505 B1	11/2003	Heierli
D484,610 S	12/2003	Lockwood
6,719,492 B1	4/2004	Heierli
D490,533 S	5/2004	Lockwood
6,854,928 B2	2/2005	Lockwood
6,922,950 B2	8/2005	Heierli
D511,215 S	11/2005	Vaia
D511,387 S	11/2005	Beach
6,962,465 B2	11/2005	Zax et al.
D512,513 S	12/2005	Wasniak et al.
6,988,337 B1	1/2006	Heierli
D514,706 S	2/2006	Beach
7,001,110 B2	2/2006	Lockwood
7,114,305 B2	10/2006	Heierli
7,217,064 B1	5/2007	Wilson
7,305,798 B1	12/2007	Heierli
D566,852 S	4/2008	Gaster et al.
D573,722 S	7/2008	Lockwood
7,556,451 B2	7/2009	Beach et al.
7,568,860 B2	8/2009	Chiaves

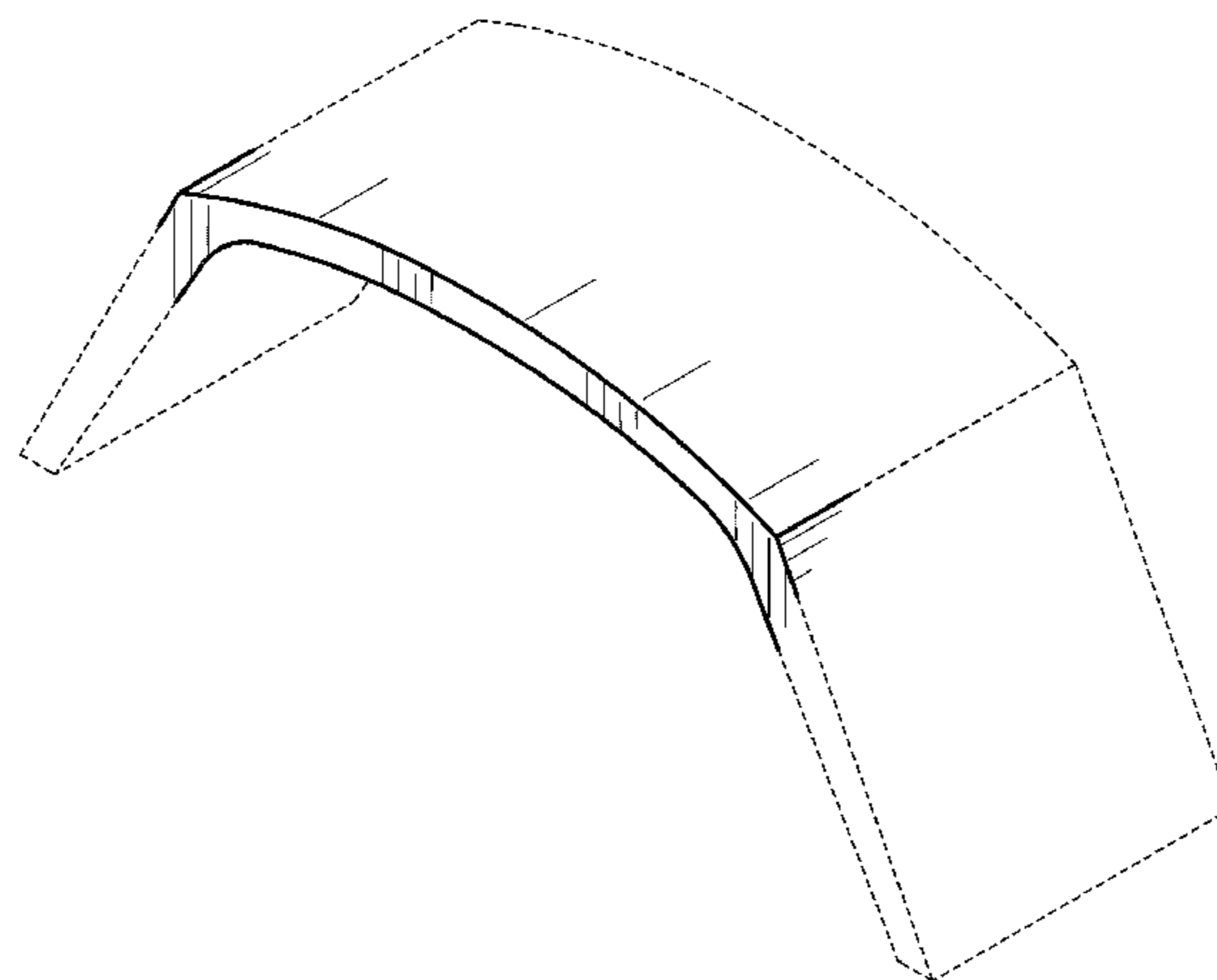

7,572,084	B2 *	8/2009	Robertson et al.	405/126
7,770,250	B2	8/2010	Boresi et al.	
D645,572	S *	9/2011	Von Handorf	D25/102
D658,976	S	5/2012	Morrow	
2004/0062609	A1 *	4/2004	Heierli	405/124
2005/0123354	A1	6/2005	Zax et al.	
2006/0174549	A1	8/2006	Dagher et al.	
2009/0183321	A1	7/2009	Bores et al.	

FOREIGN PATENT DOCUMENTS

EP	0244890	11/1987
EP	0568799	11/1996
FR	2330818	6/1977
WO	WO 92/07144	4/1992

OTHER PUBLICATIONS

Design U.S. Appl. No. 29/417,404, filed Apr. 3, 2012, entitled "Concrete Bridge Unit".

* cited by examiner

Primary Examiner — T. Chase Nelson

Assistant Examiner — Kathleen M Sims

(74) *Attorney, Agent, or Firm* — Thompson Hine LLP

(57) **CLAIM**

The ornamental design for a upper portion of a concrete bridge unit, as shown and described.

DESCRIPTION

FIG. 1 is a perspective view of the front top portion of a first embodiment of a concrete bridge unit;
 FIG. 2 is a front elevation of the concrete bridge unit of FIG. 1;
 FIG. 3 is a side elevation of the concrete bridge unit of FIG. 1;
 FIG. 4 is a perspective view of the front top portion of a second embodiment of a concrete bridge unit;
 FIG. 5 is a front elevation of the concrete bridge unit of FIG. 4;
 FIG. 6 is a side elevation of the concrete bridge unit of FIG. 4;
 FIG. 7 is a perspective view of the front top portion of a third embodiment of a concrete bridge unit;
 FIG. 8 is a front elevation of the concrete bridge unit of FIG. 7;
 FIG. 9 is a side elevation of the concrete bridge unit of FIG. 7;
 FIG. 10 is a perspective view of the front top portion of a fourth embodiment of a concrete bridge unit;
 FIG. 11 is a front elevation of the concrete bridge unit of FIG. 10;
 FIG. 12 is a side elevation of the concrete bridge unit of FIG. 10;
 FIG. 13 is a perspective view of the front top portion of a fifth embodiment of a concrete bridge unit;

FIG. 14 is a front elevation of the concrete bridge unit of FIG. 13;
 FIG. 15 is a side elevation of the concrete bridge unit of FIG. 13;
 FIG. 16 is a perspective view of the front top portion of a sixth embodiment of a concrete bridge unit;
 FIG. 17 is a front elevation of the concrete bridge unit of FIG. 16;
 FIG. 18 is a side elevation of the concrete bridge unit of FIG. 16;
 FIG. 19 is a perspective view of the front top portion of a seventh embodiment of a concrete bridge unit;
 FIG. 20 is a front elevation of the concrete bridge unit of FIG. 19;
 FIG. 21 is a side elevation of the concrete bridge unit of FIG. 19;
 FIG. 22 is a perspective view of the front top portion of an eighth embodiment of a concrete bridge unit;
 FIG. 23 is a front elevation of the concrete bridge unit of FIG. 22;
 FIG. 24 is a side elevation of the concrete bridge unit of FIG. 22;
 FIG. 25 is a perspective view of the front top portion of a ninth embodiment of a concrete bridge unit;
 FIG. 26 is a front elevation of the concrete bridge unit of FIG. 25;
 FIG. 27 is a side elevation of the concrete bridge unit of FIG. 25;
 FIG. 28 is a perspective view of the front top portion of a tenth embodiment of a concrete bridge unit;
 FIG. 29 is a front elevation of the concrete bridge unit of FIG. 28;
 FIG. 30 is a side elevation of the concrete bridge unit of FIG. 28;
 FIG. 31 is a perspective view of the front top portion of an eleventh embodiment of a concrete bridge unit;
 FIG. 32 is a front elevation of the concrete bridge unit of FIG. 31;
 FIG. 33 is a side elevation of the concrete bridge unit of FIG. 31;
 FIG. 34 is a perspective view of the front top portion of a twelfth embodiment of a concrete bridge unit;
 FIG. 35 is a front elevation of the concrete bridge unit of FIG. 34; and,
 FIG. 36 is a side elevation of the concrete bridge unit of FIG. 34.
 The broken lines shown in the drawings are for purposes of illustrating portions of the upper portion of a concrete bridge unit that form no part of the claimed design.

1 Claim, 12 Drawing Sheets

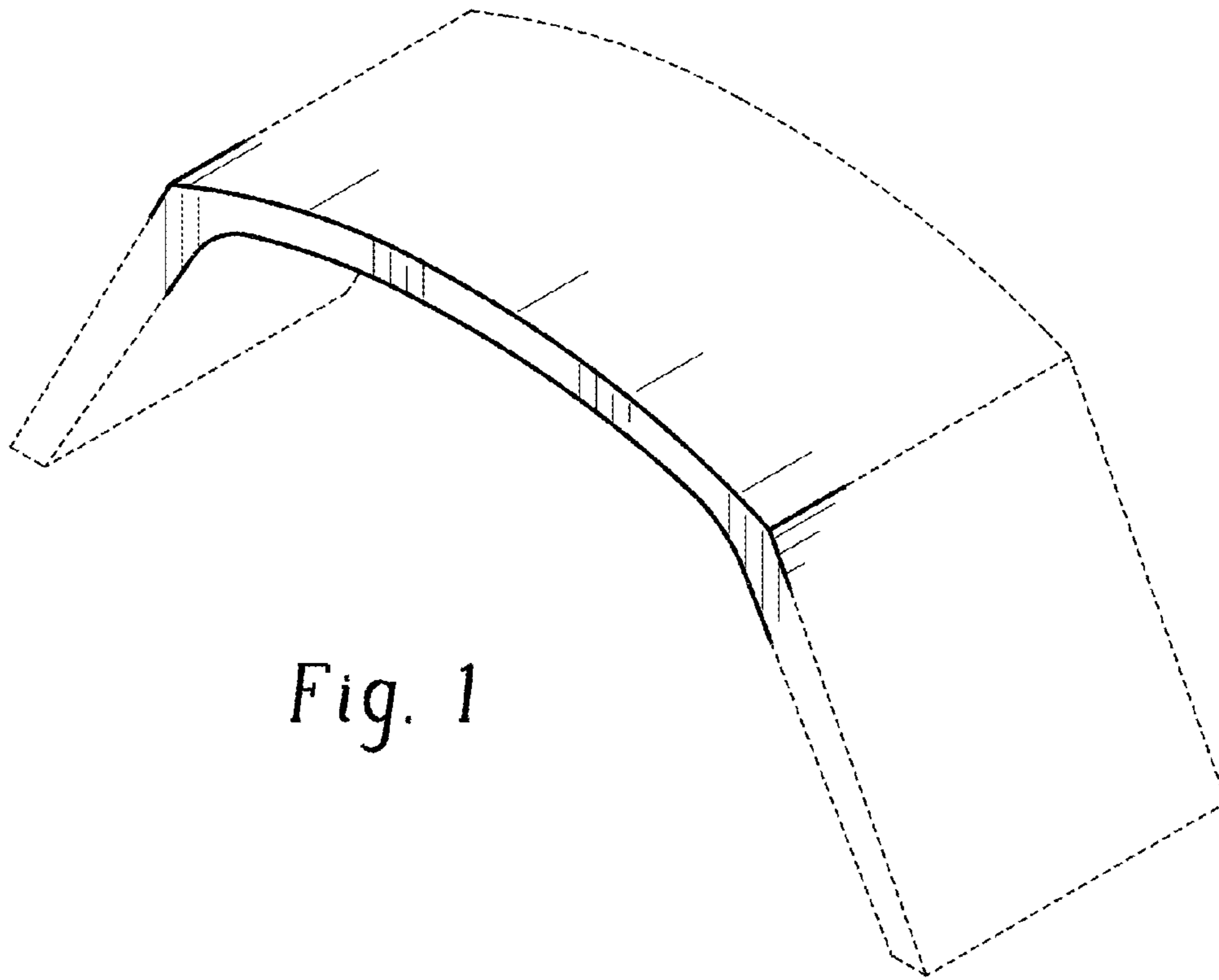

Fig. 1

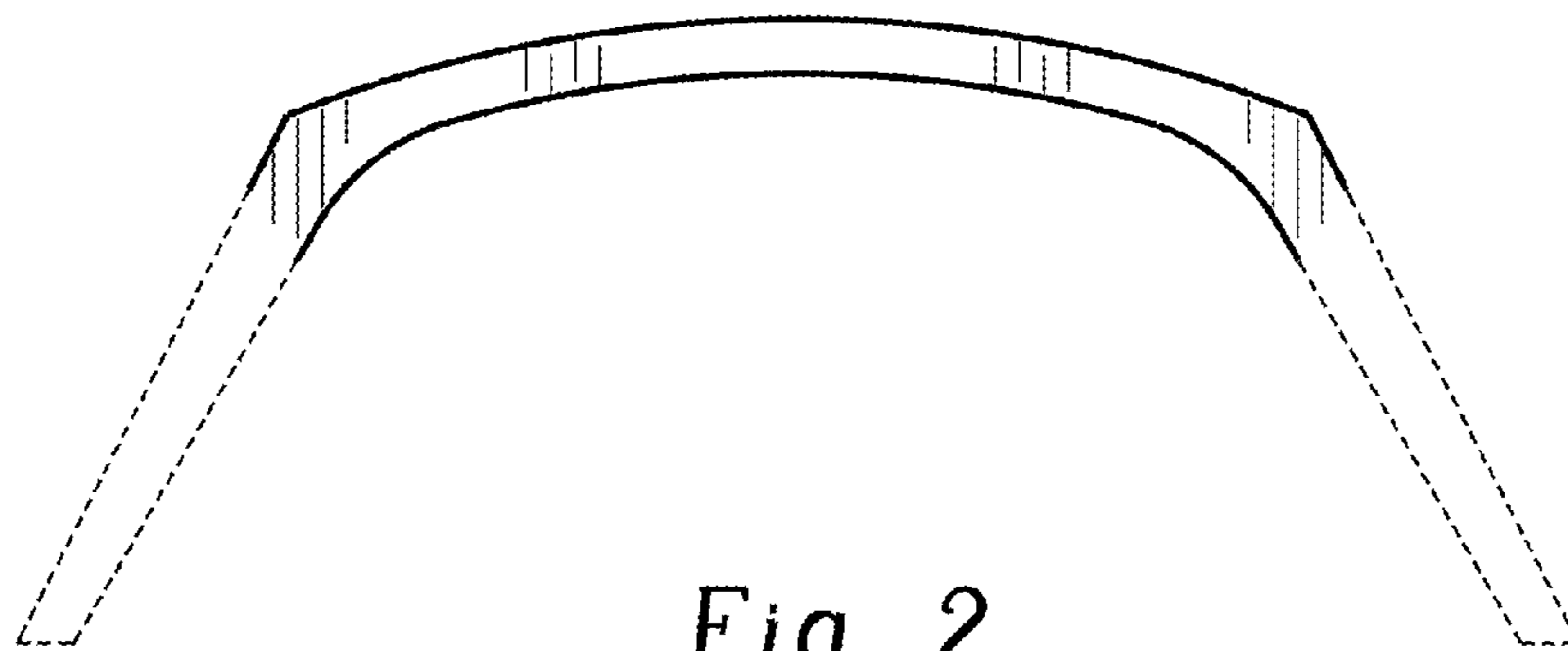

Fig. 2

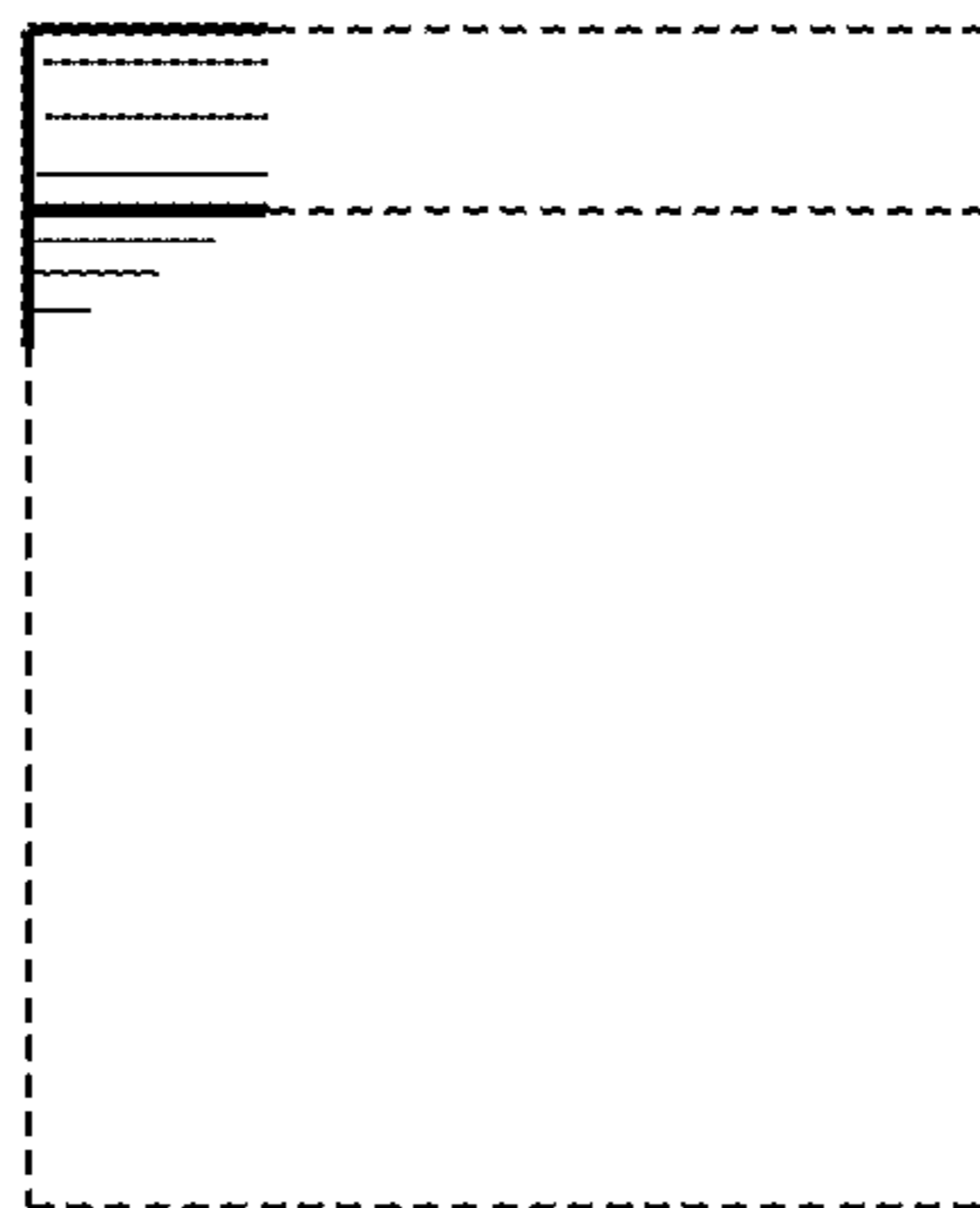

Fig. 3

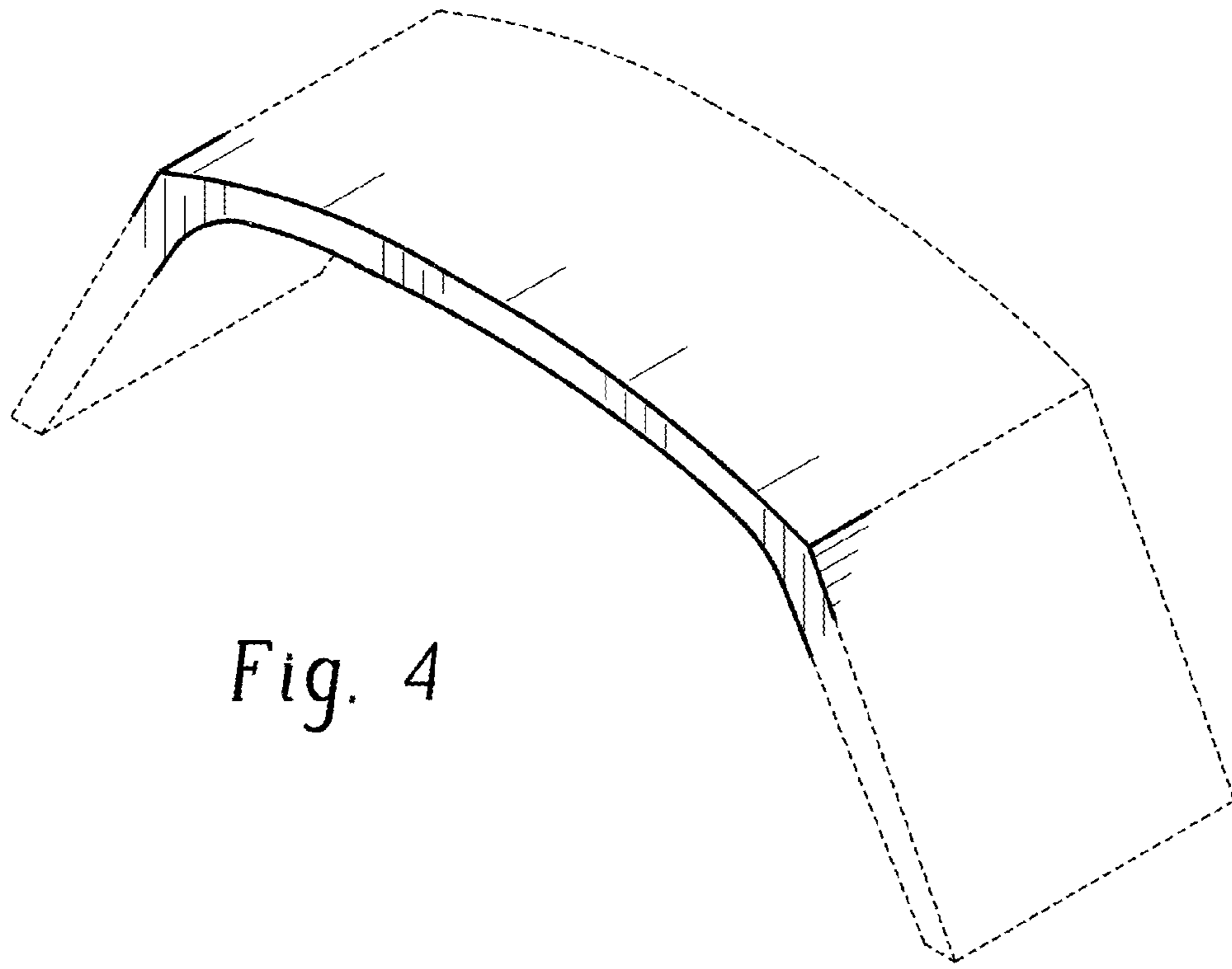

Fig. 4

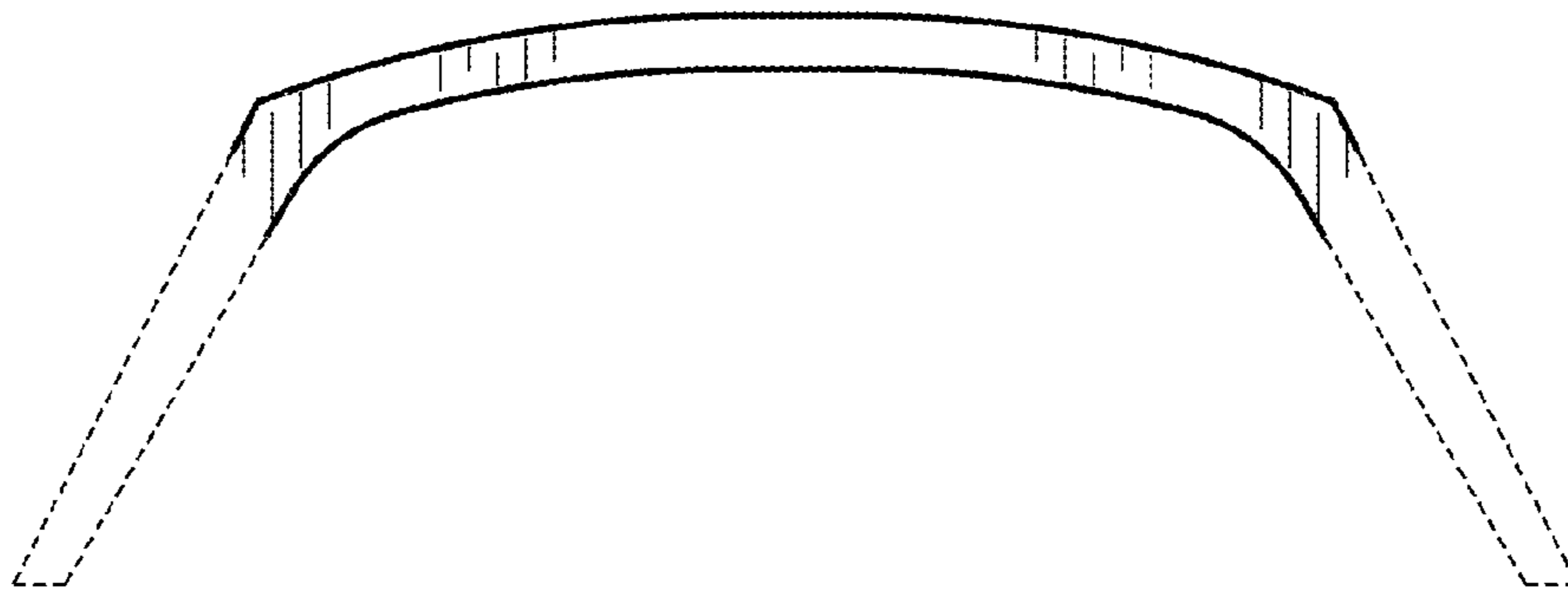

Fig. 5

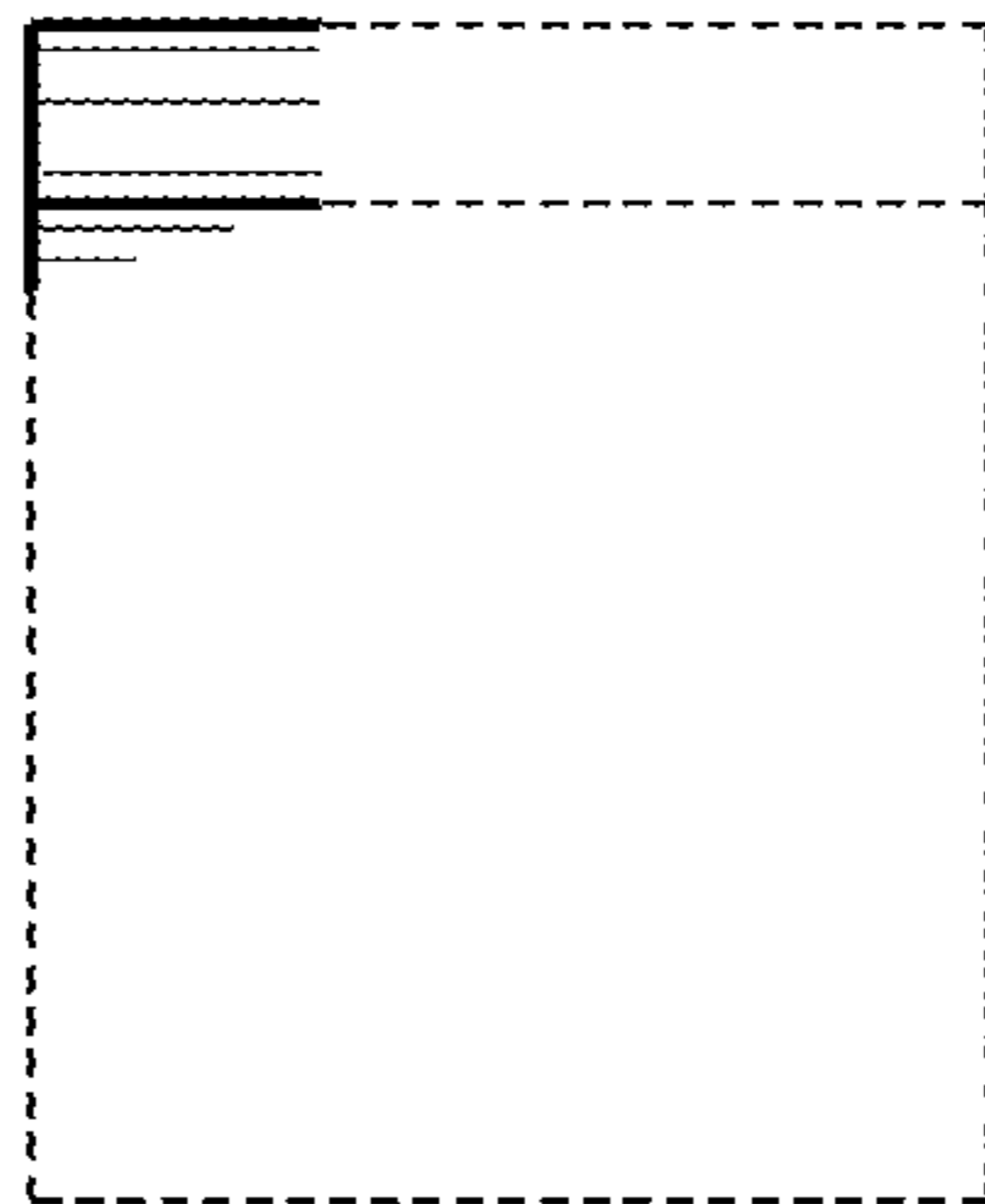

Fig. 6

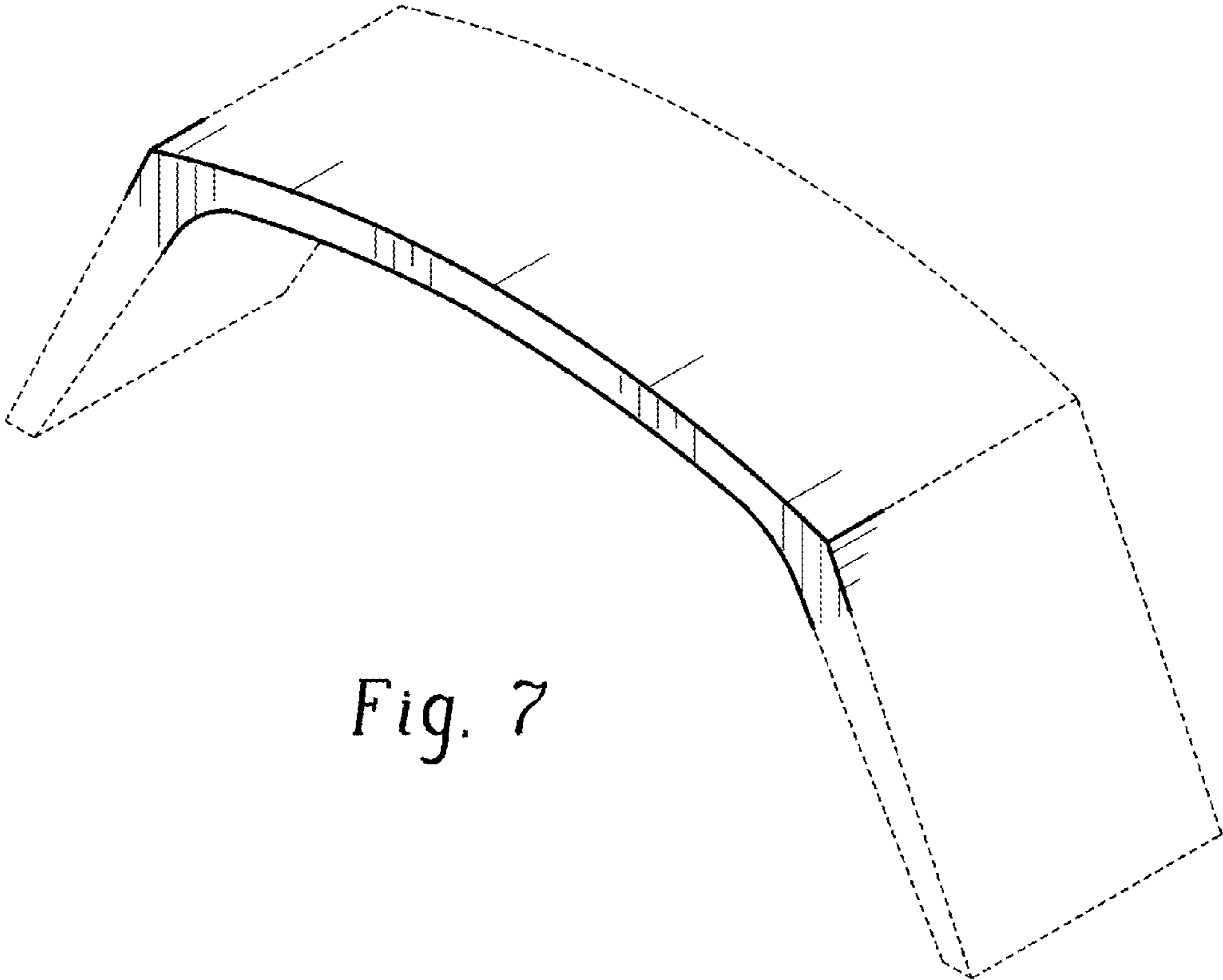

Fig. 7

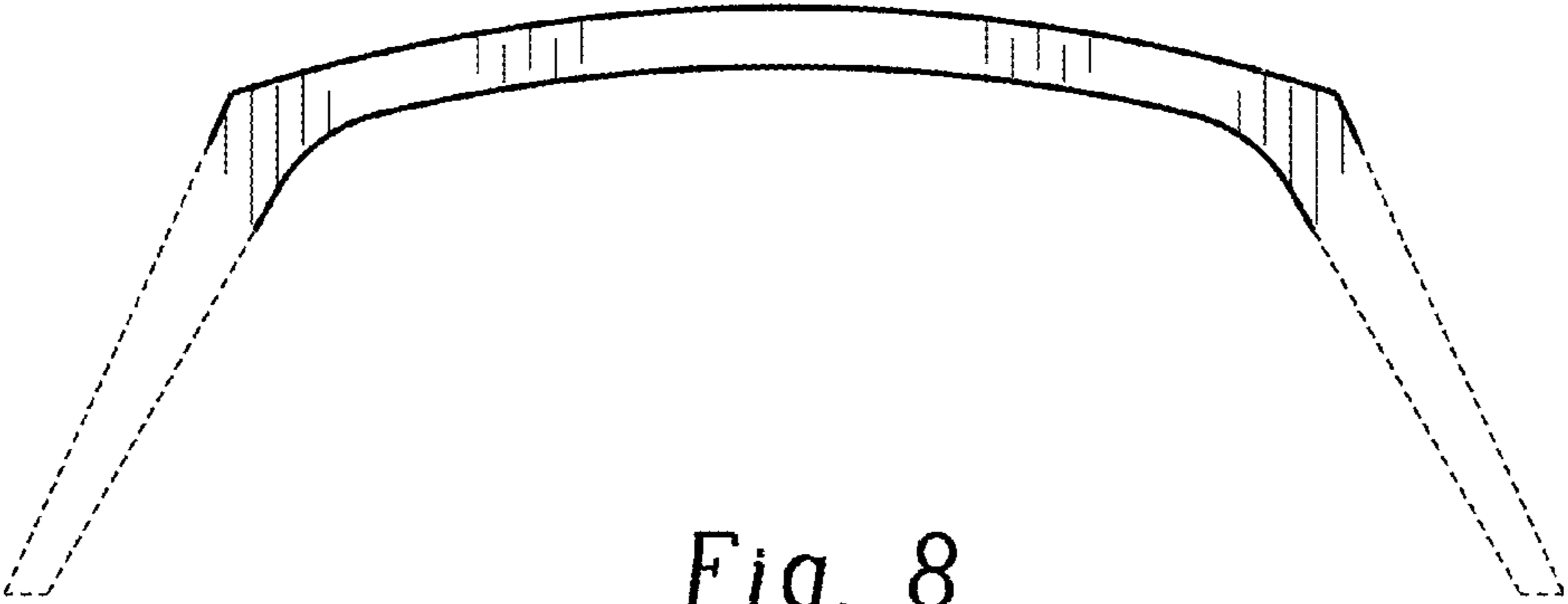

Fig. 8

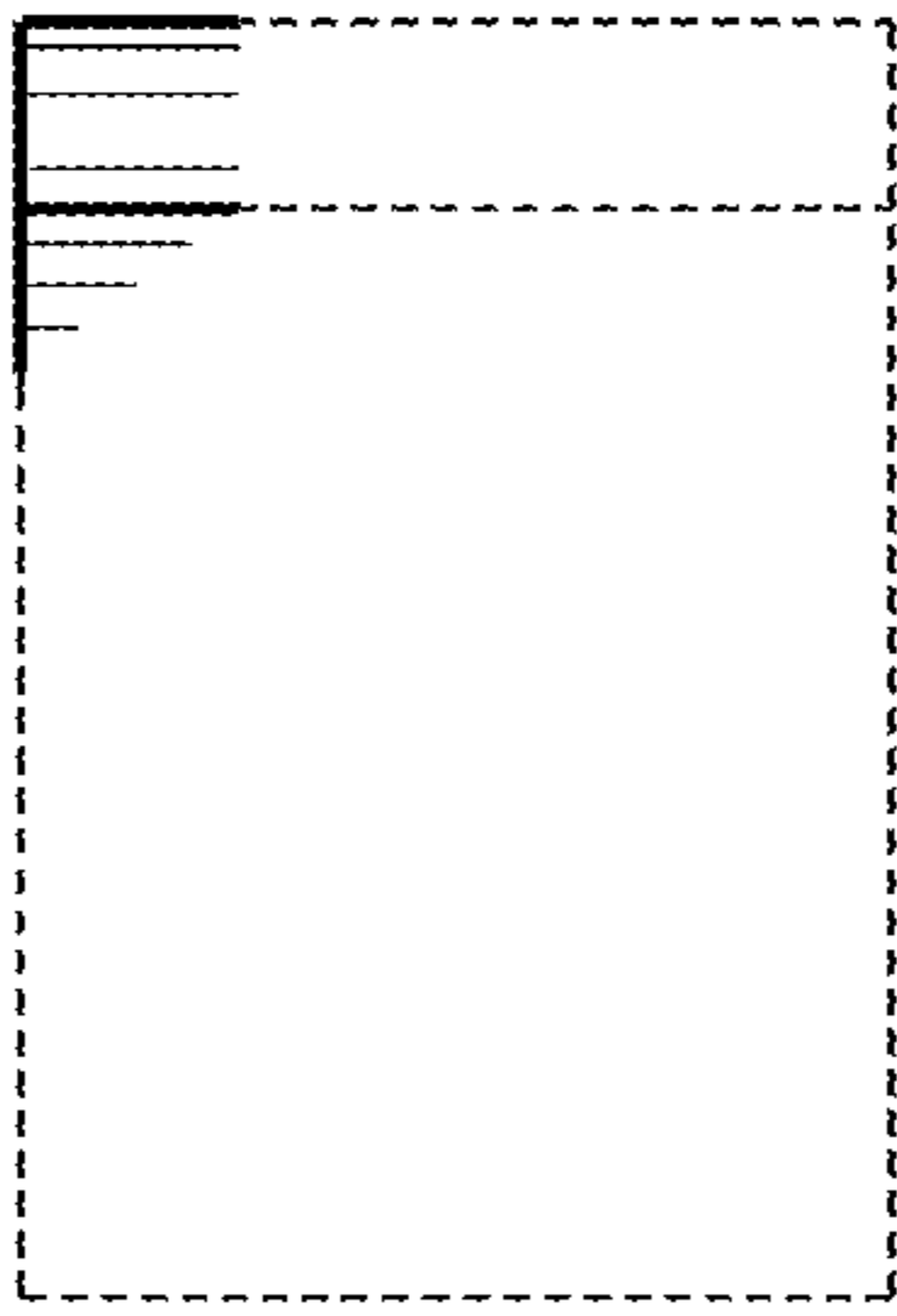

Fig. 9

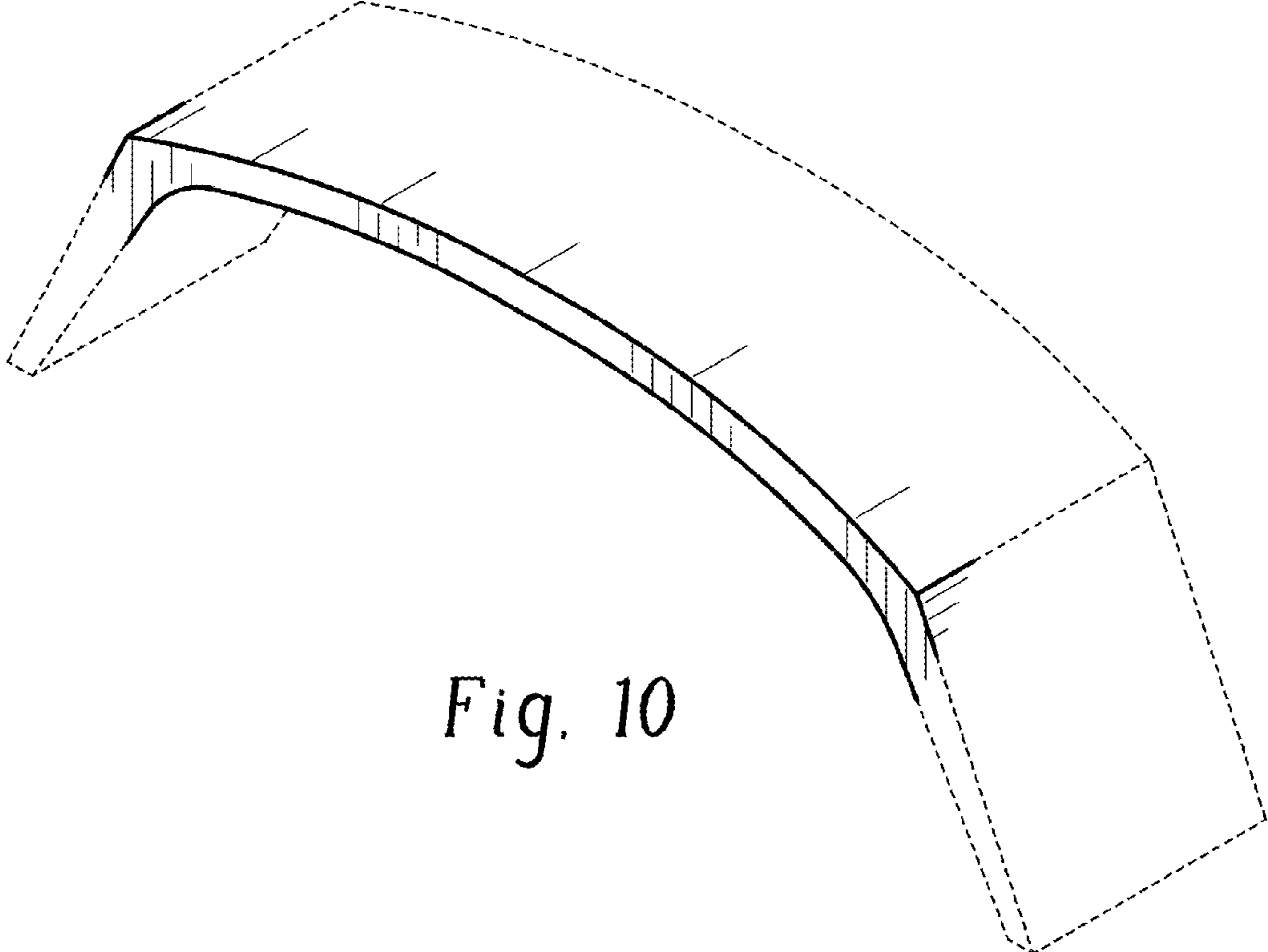

Fig. 10

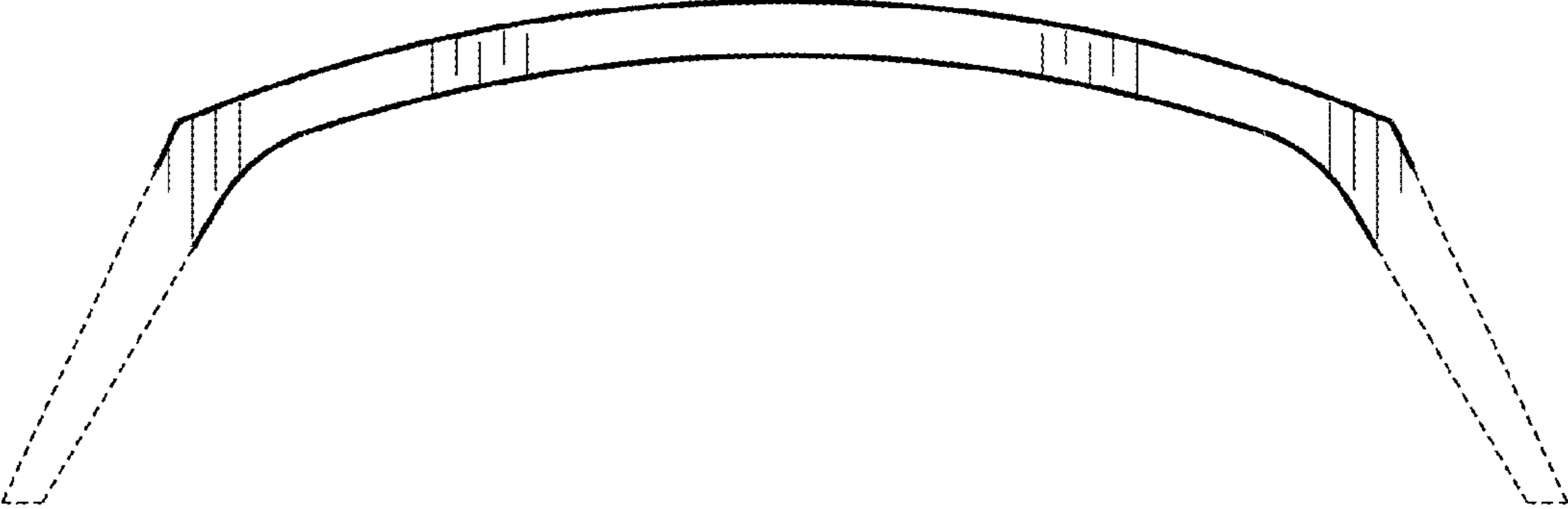

Fig. 11

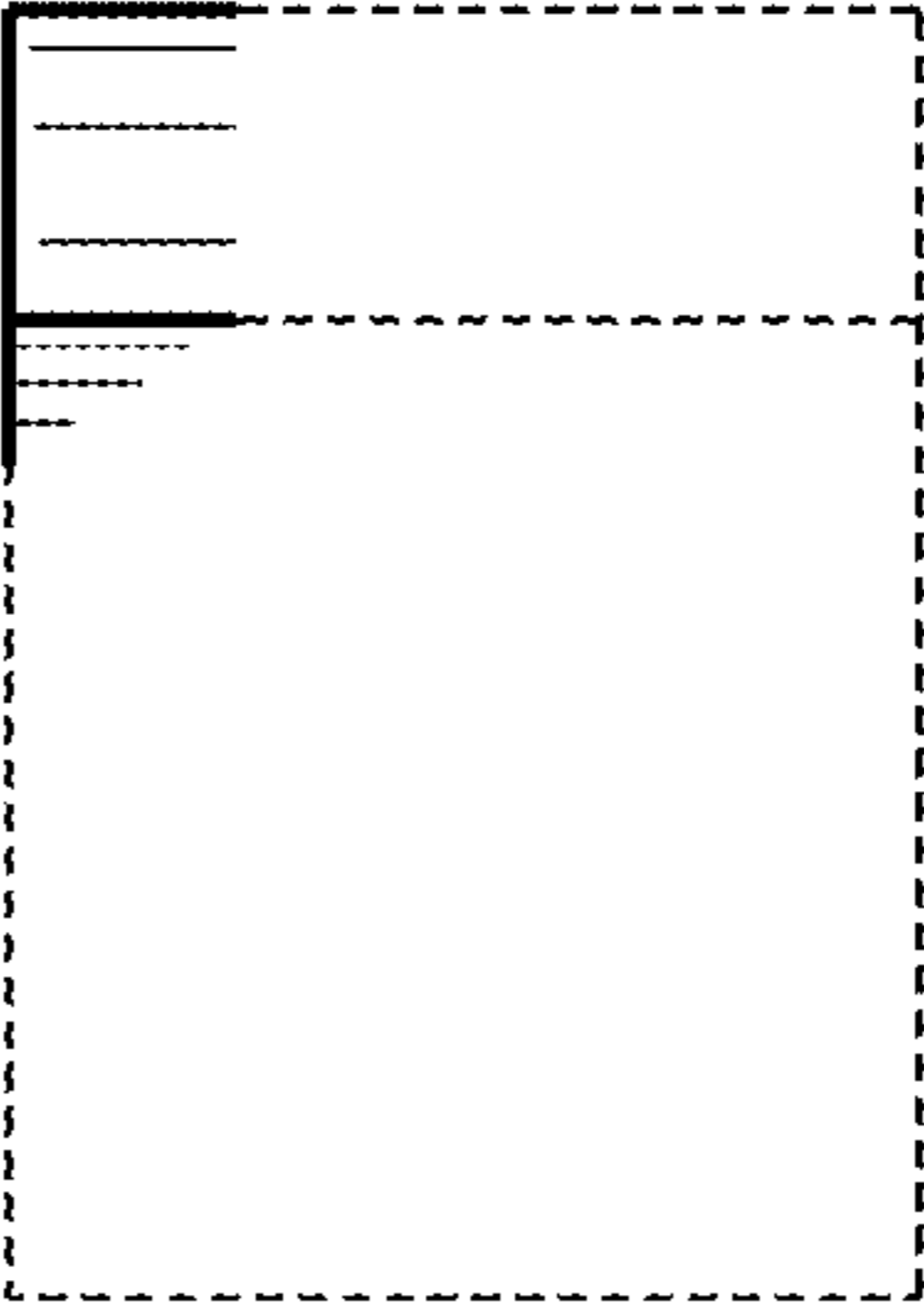

Fig. 12

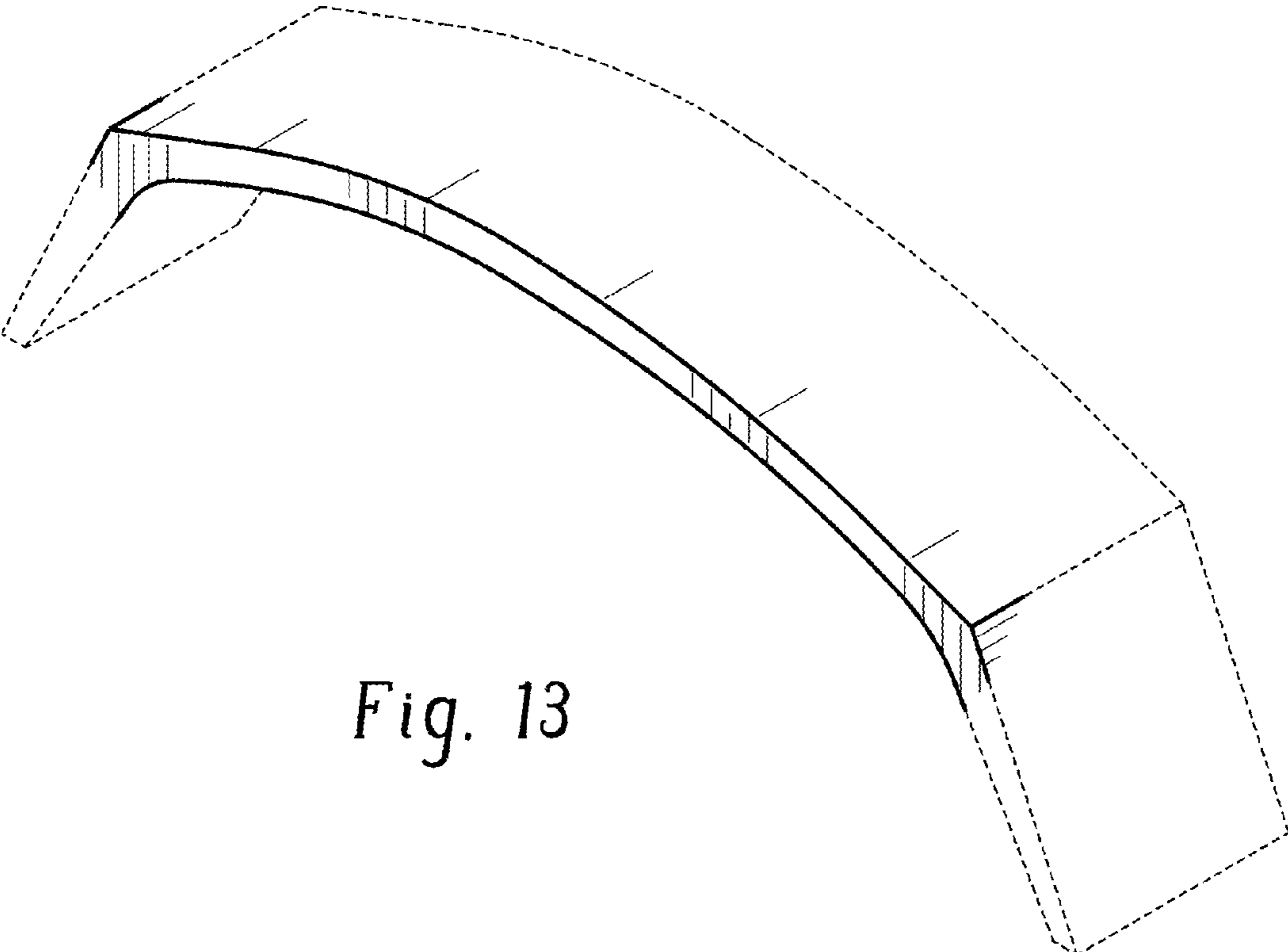

Fig. 13

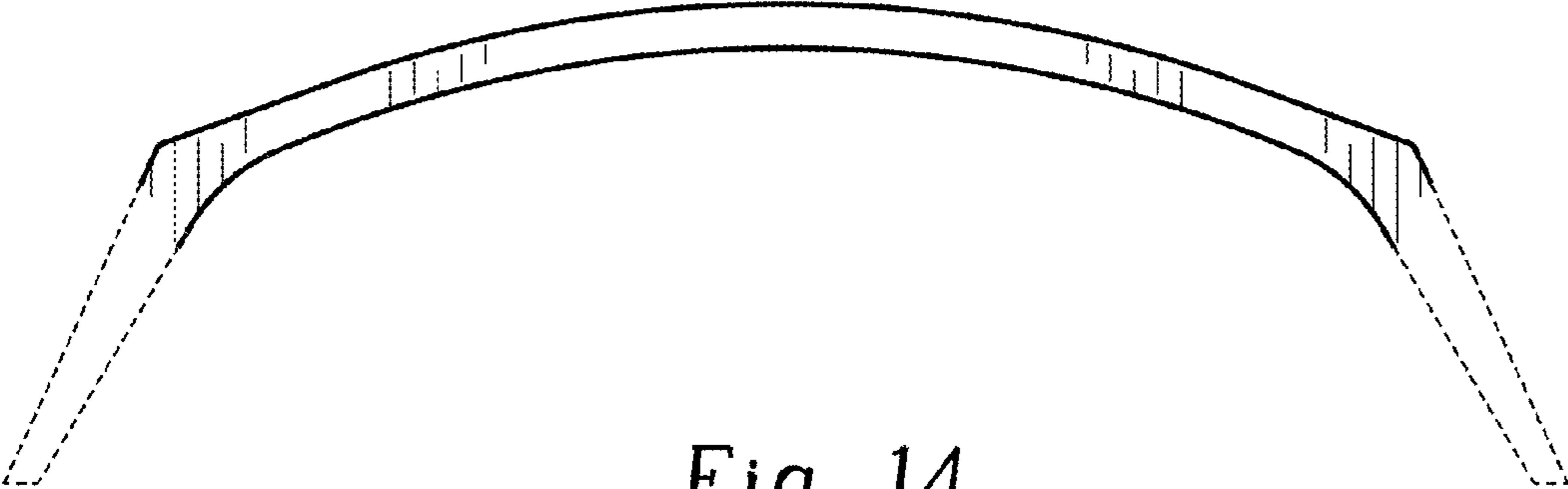

Fig. 14

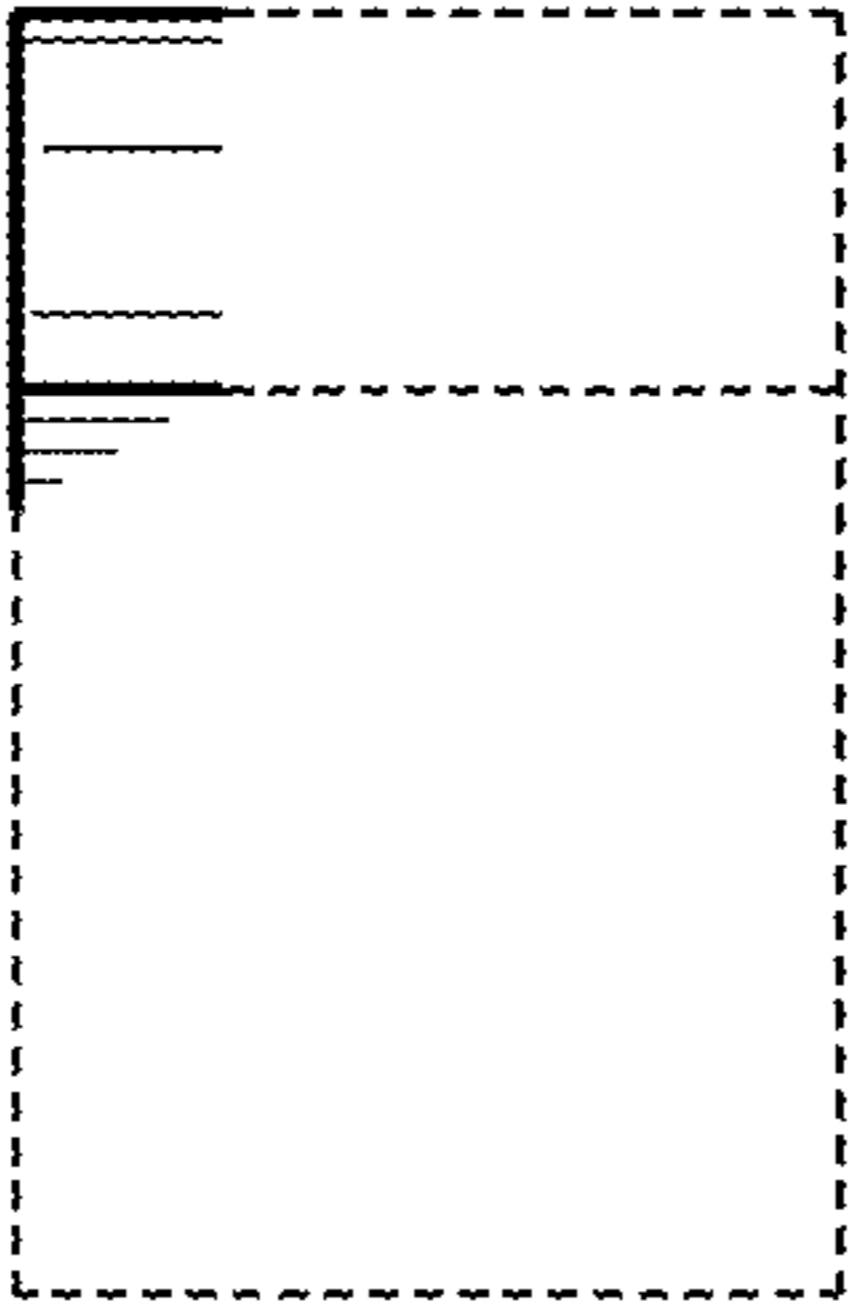

Fig. 15

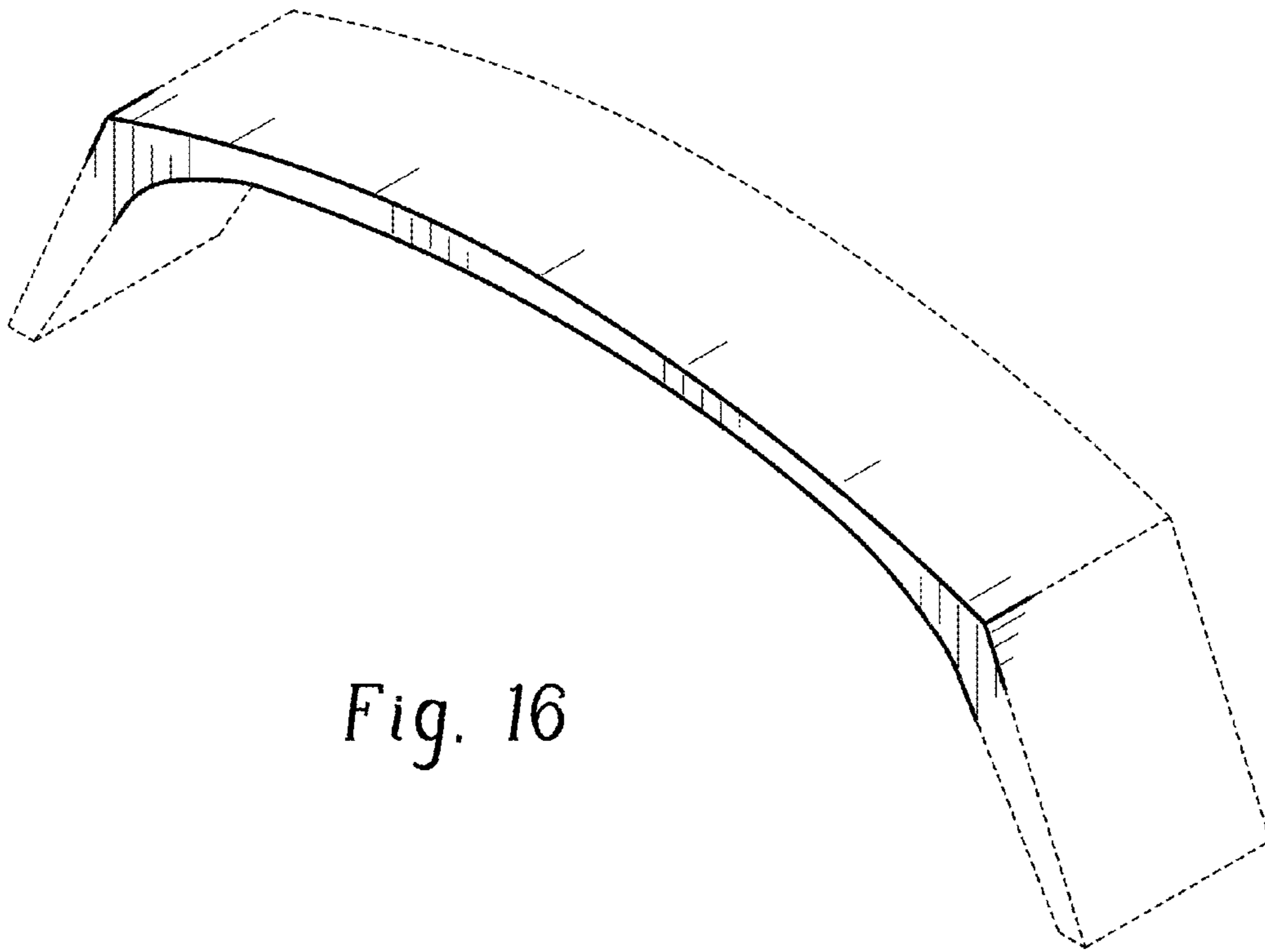

Fig. 16

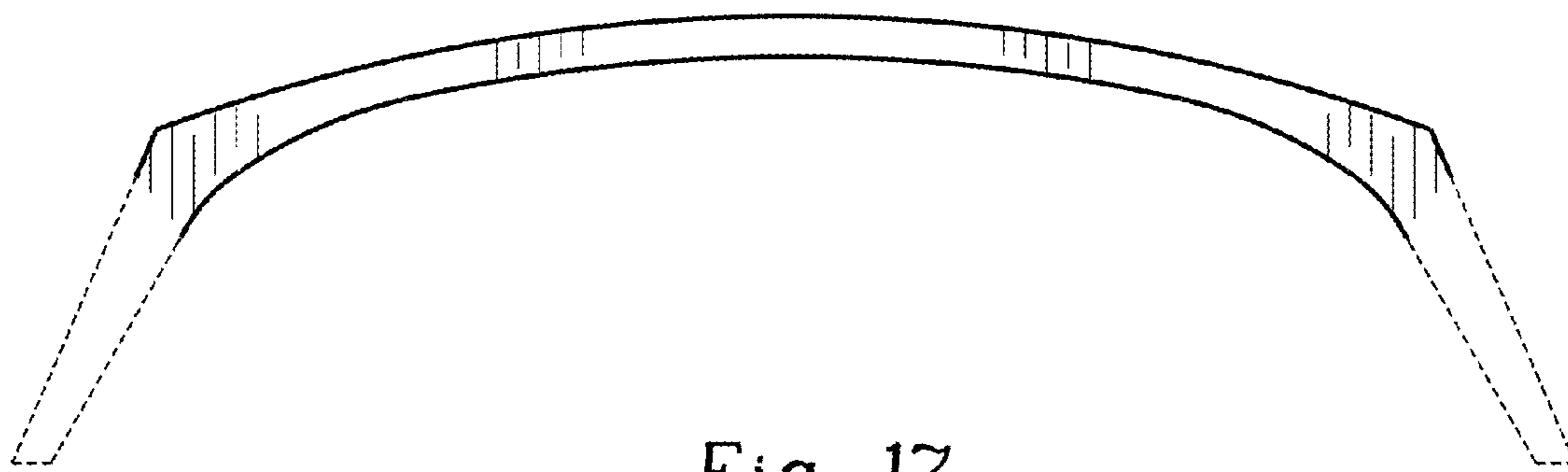

Fig. 17

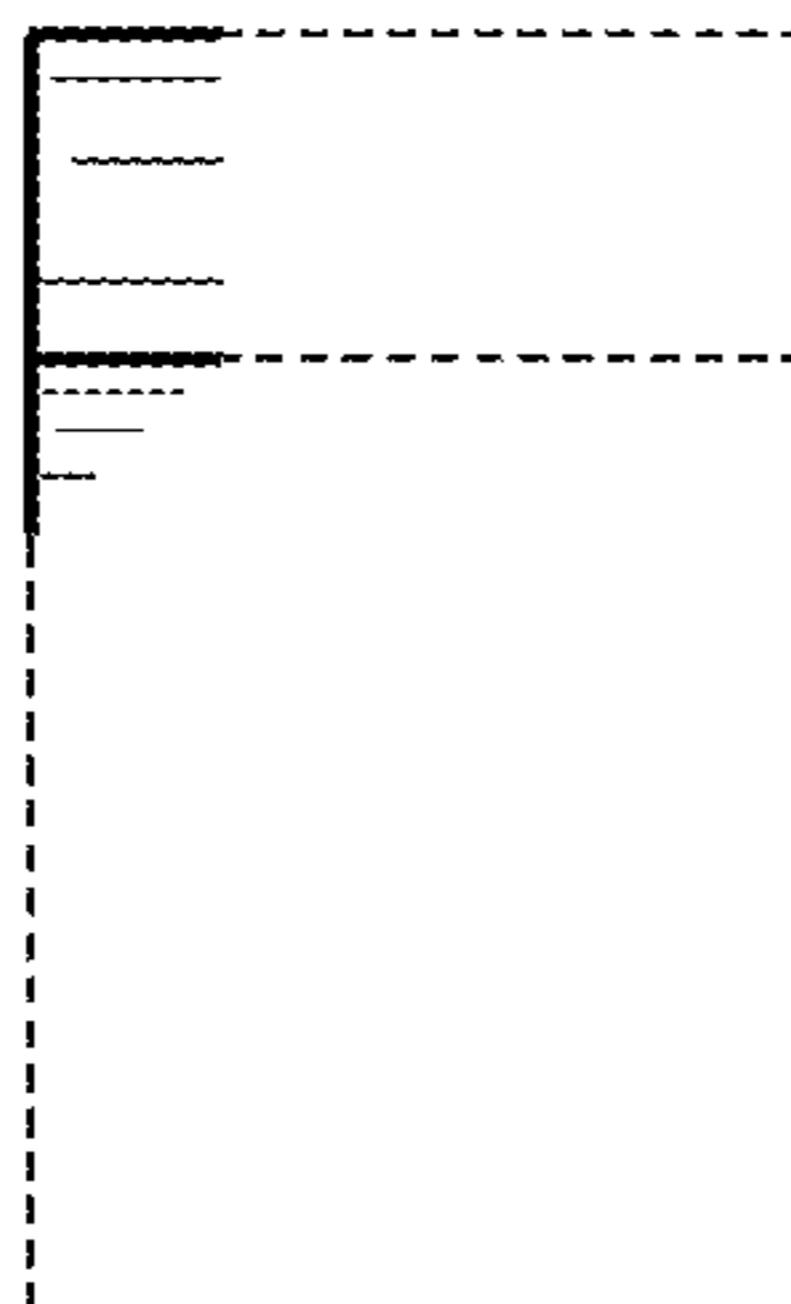

Fig. 18

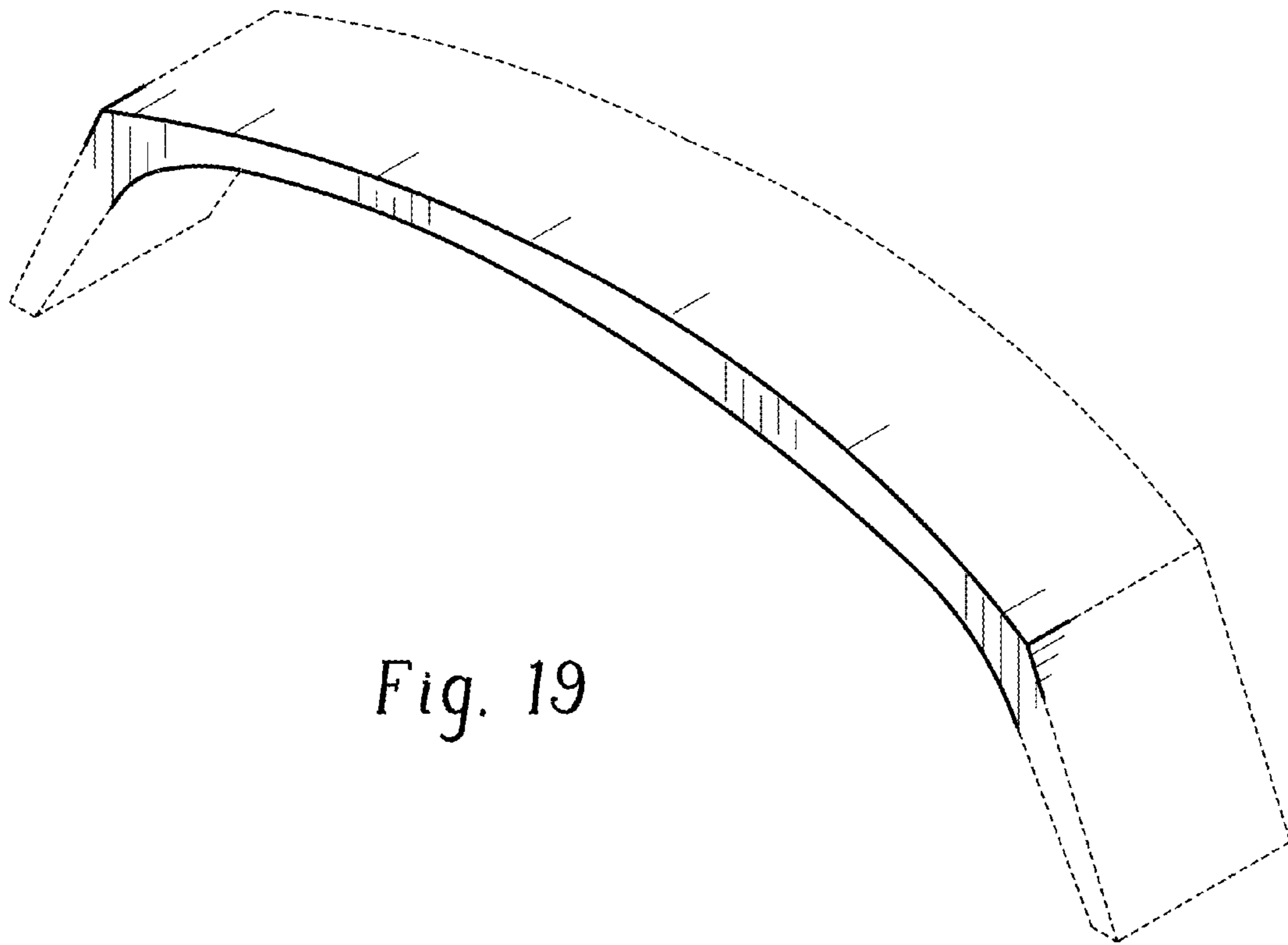

Fig. 19

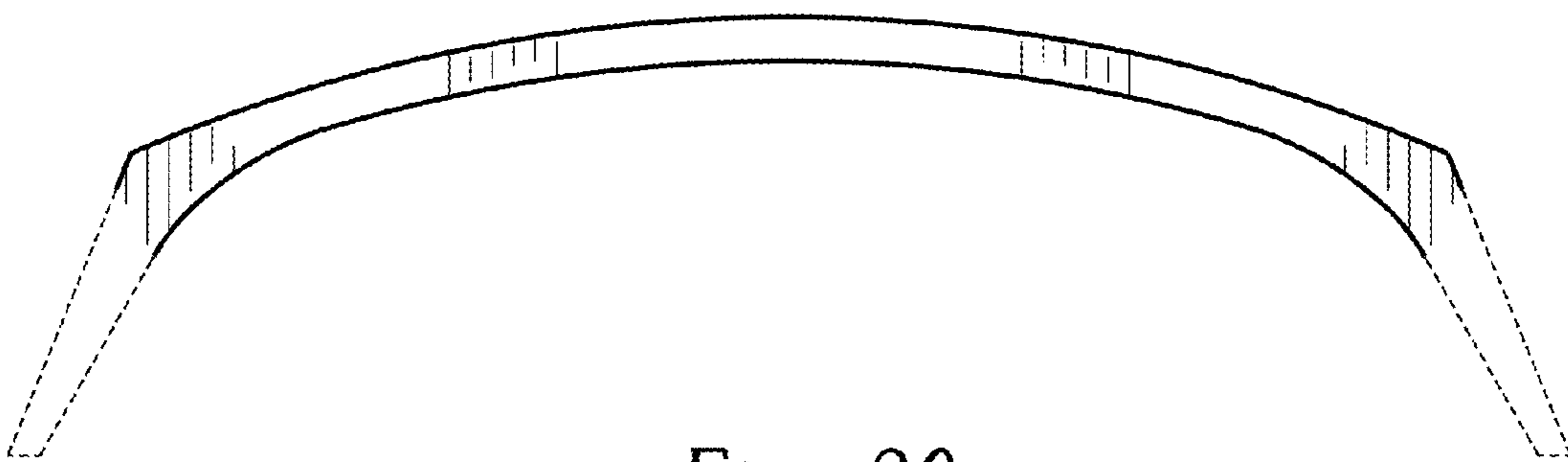

Fig. 20

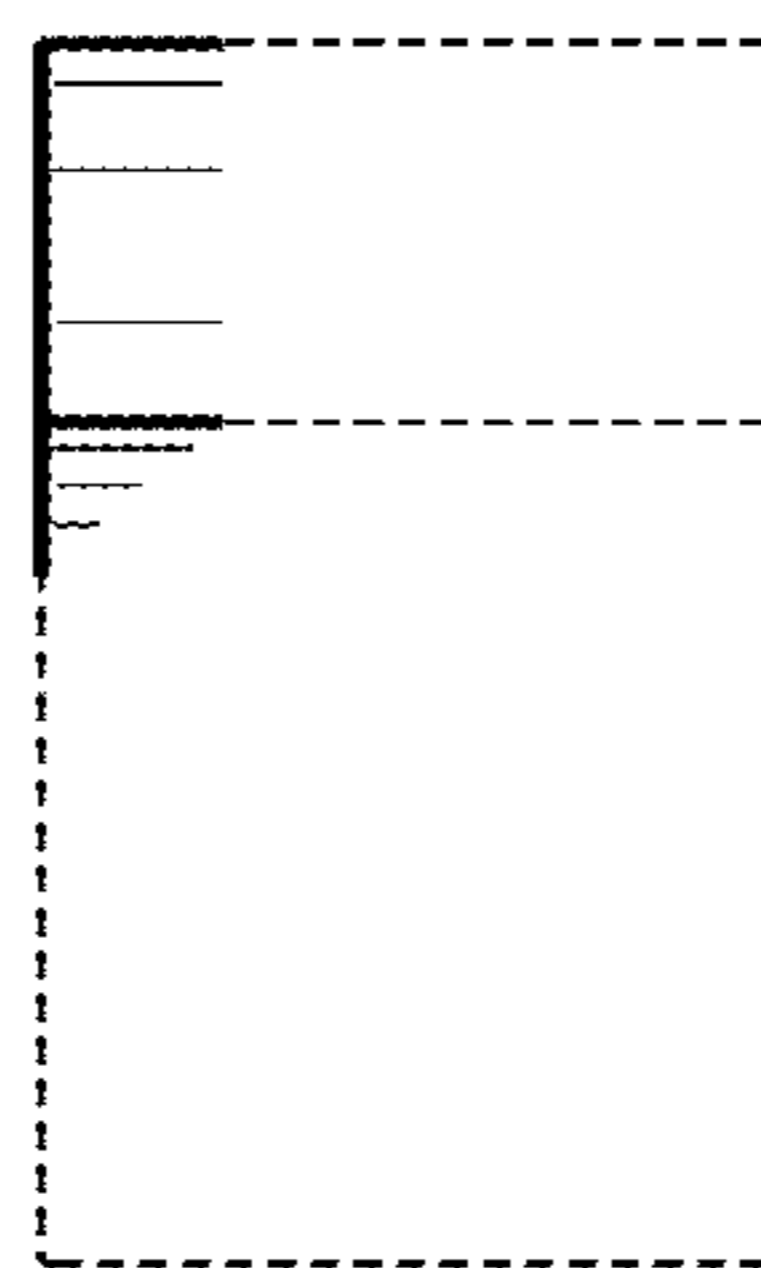

Fig. 21

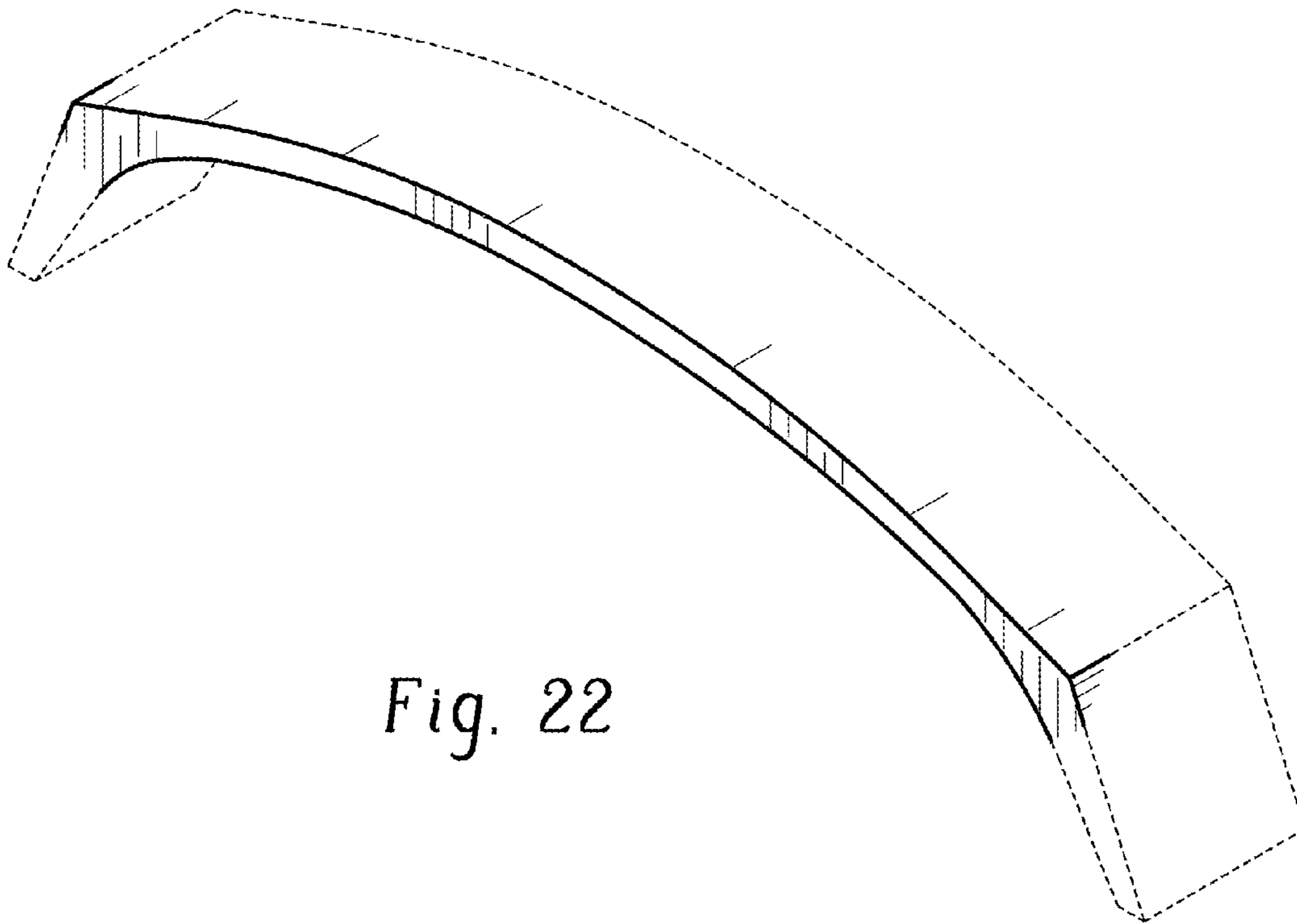

Fig. 22

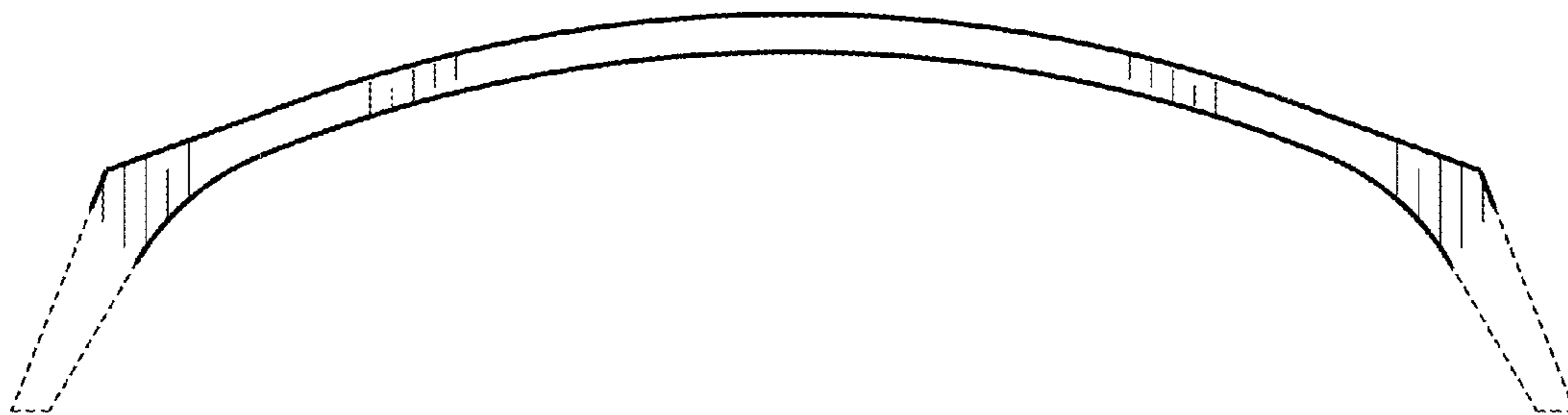

Fig. 23

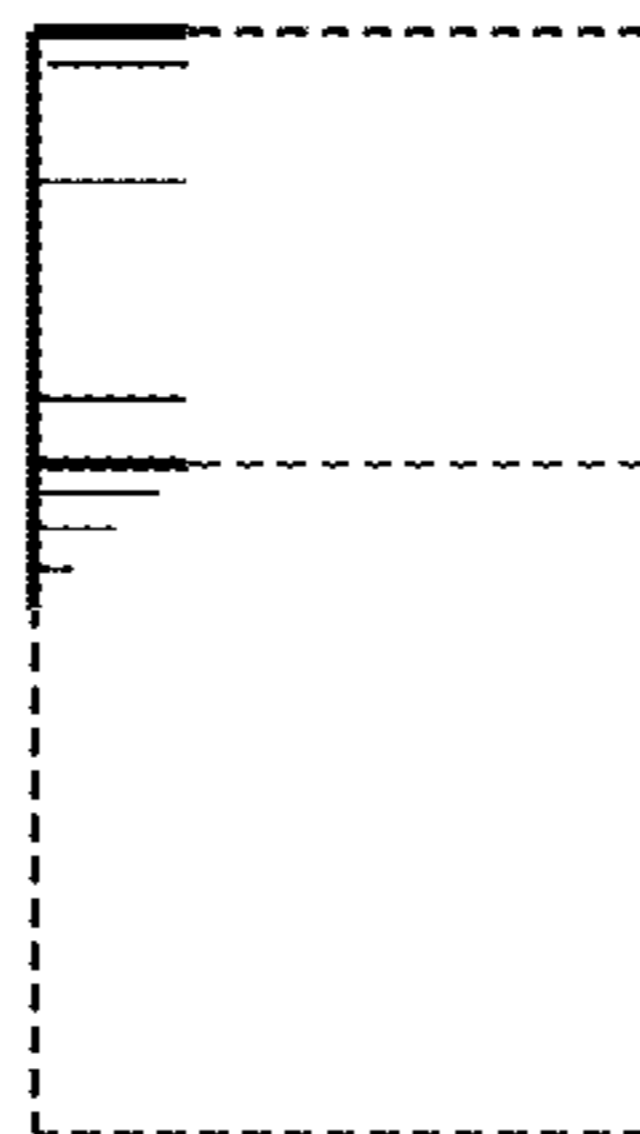

Fig. 24

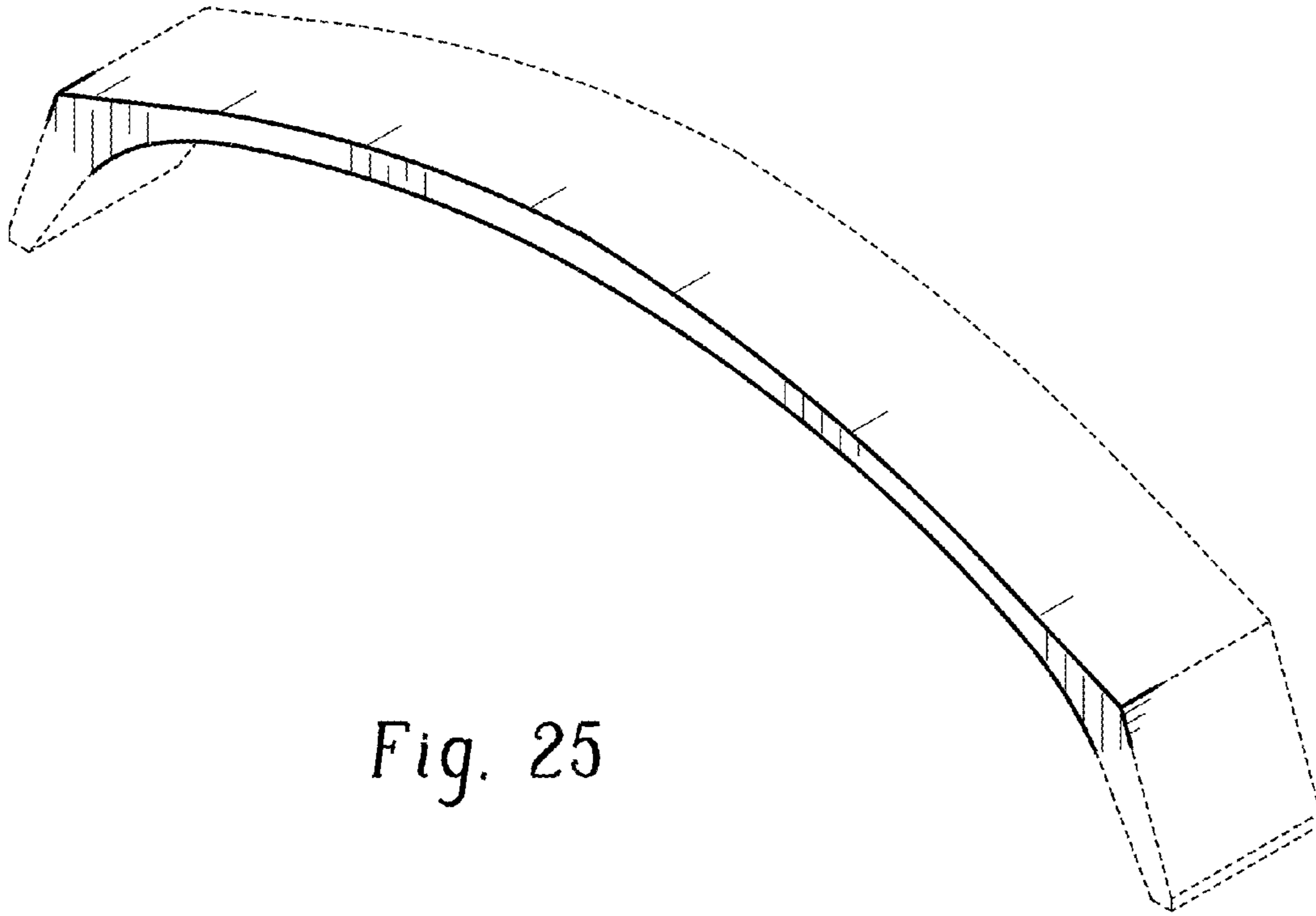

Fig. 25

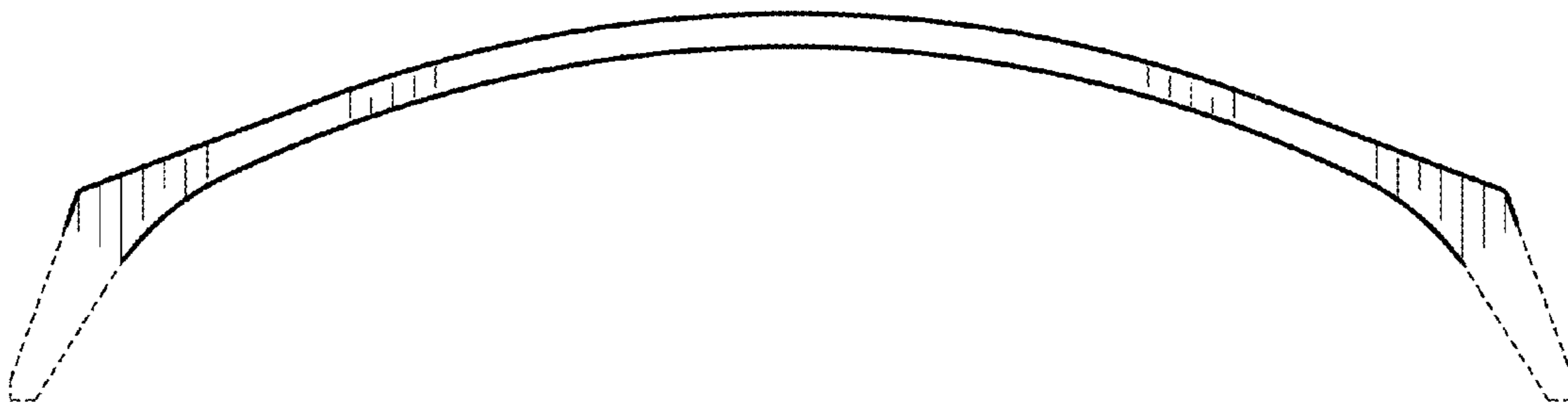

Fig. 26

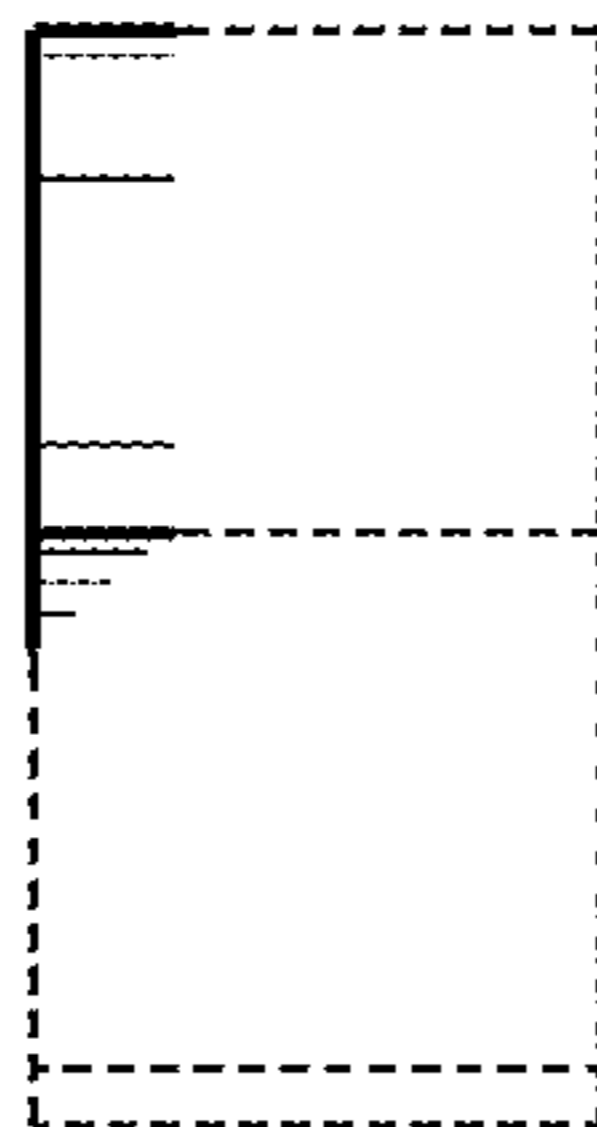

Fig. 27

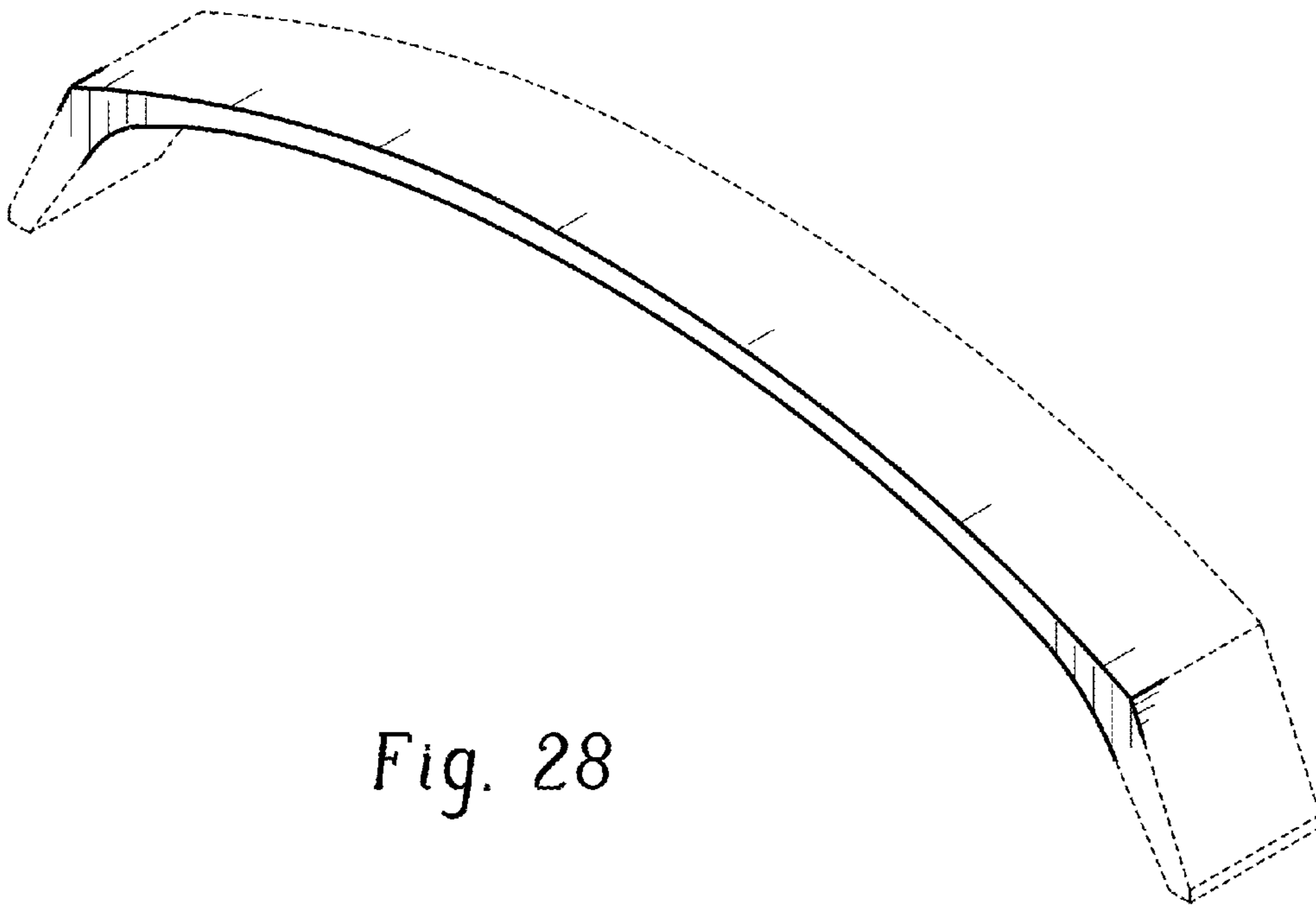

Fig. 28

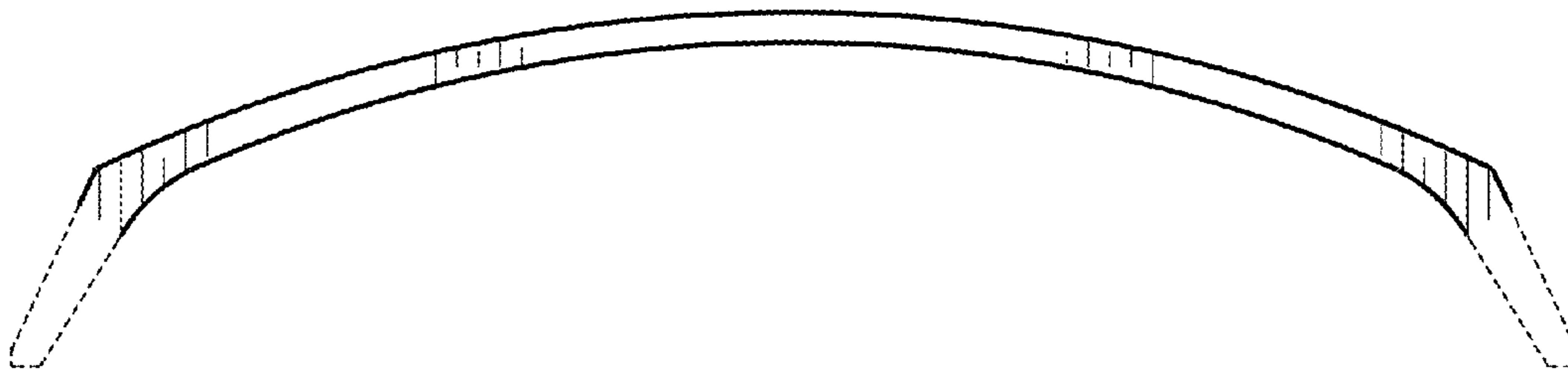

Fig. 29



Fig. 30

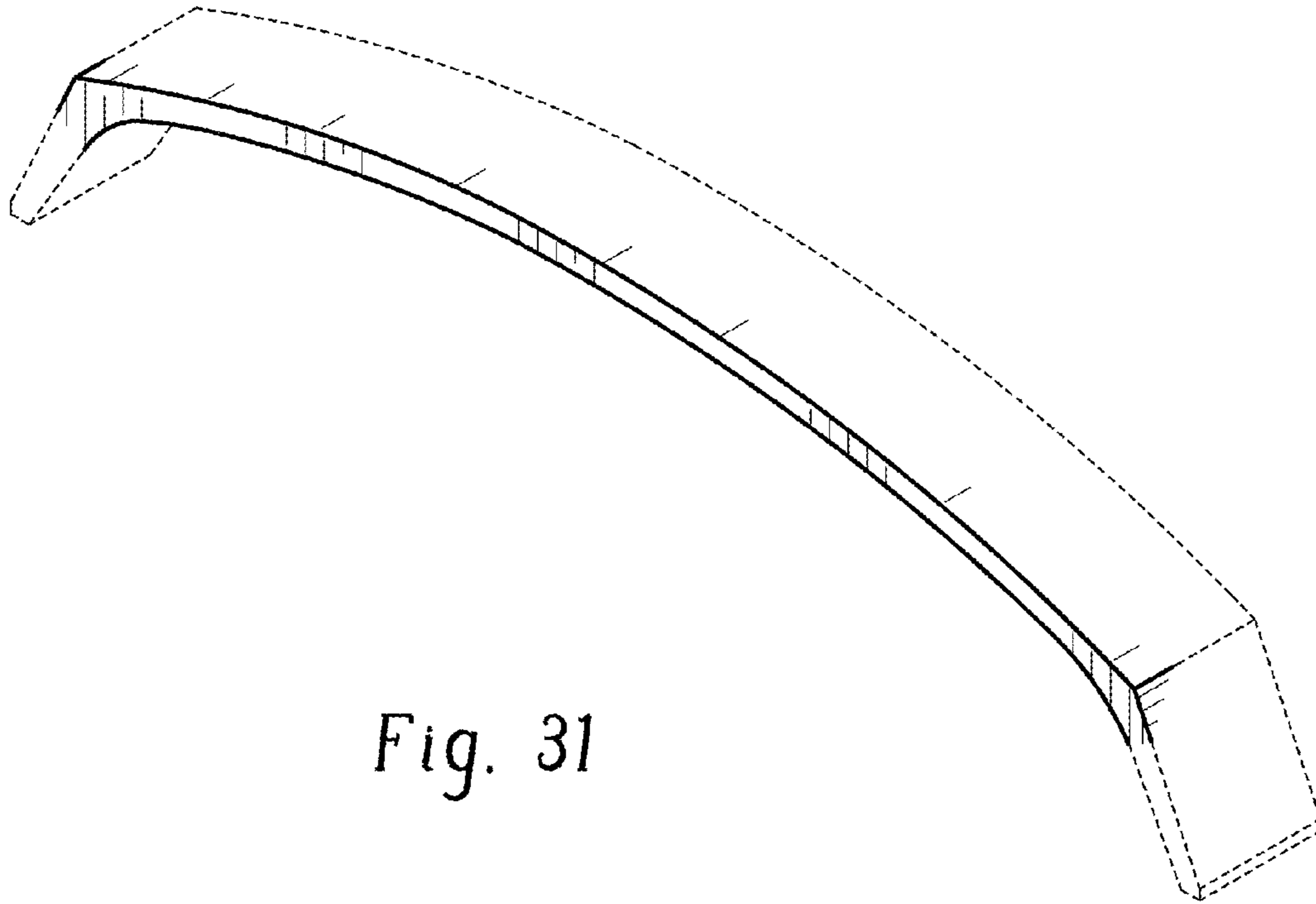

Fig. 31

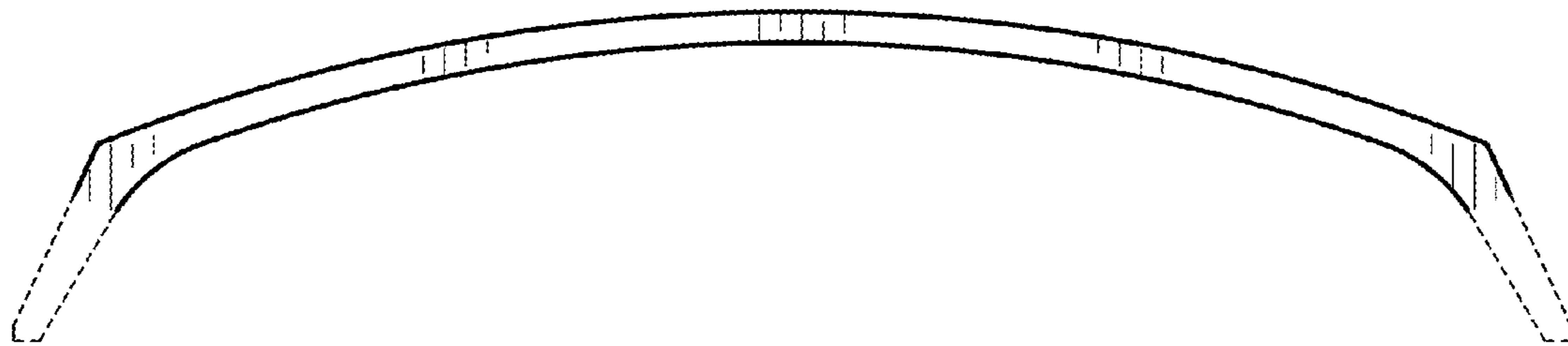

Fig. 32



Fig. 33

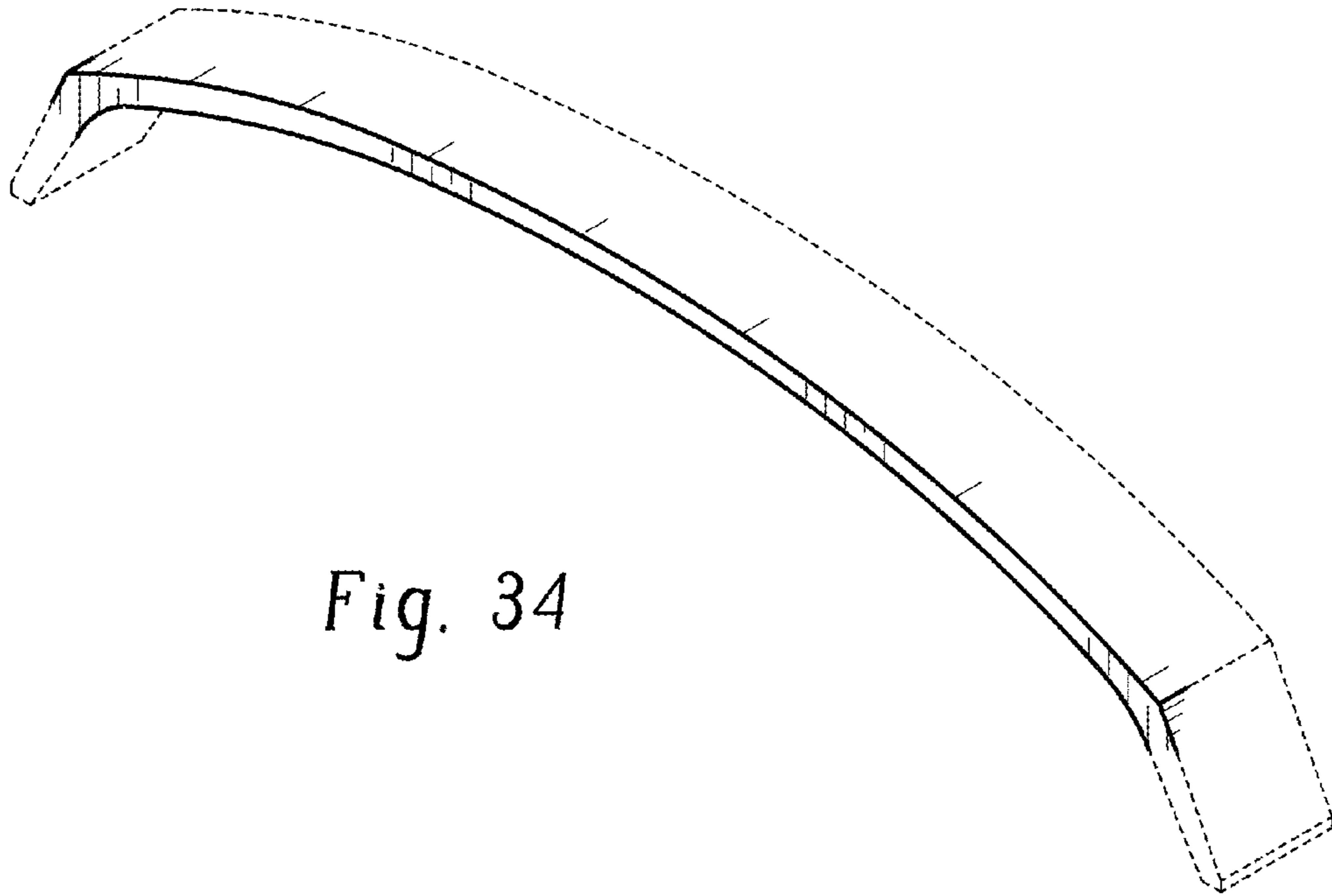

Fig. 34



Fig. 35

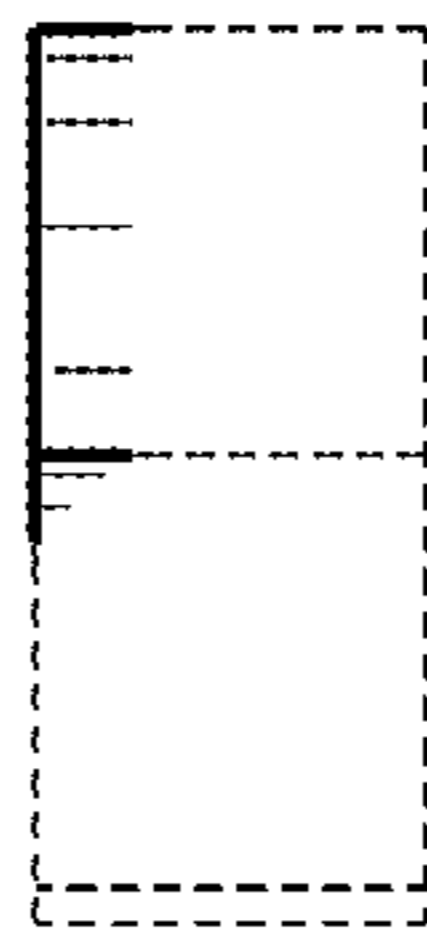

Fig. 36