



US00D697300S

(12) **United States Design Patent**  
**Alsaffar**

(10) **Patent No.:** **US D697,300 S**

(45) **Date of Patent:** **\*\* Jan. 14, 2014**

(54) **ELECTRONIC CANE FOR THE BLIND**

(71) Applicant: **Abdulreidha Abdulrasoul Alsaffar,**  
Mubarak Alkabeer (KW)

(72) Inventor: **Abdulreidha Abdulrasoul Alsaffar,**  
Mubarak Alkabeer (KW)

(\*\*) Term: **14 Years**

(21) Appl. No.: **29/460,000**

(22) Filed: **Jul. 5, 2013**

(51) **LOC (10) Cl.** ..... **03-03**

(52) **U.S. Cl.**  
USPC ..... **D3/7**

(58) **Field of Classification Search**  
USPC ..... D3/5-17; D12/130, 133; 135/65-73,  
135/76-84

See application file for complete search history.

(56) **References Cited**

**U.S. PATENT DOCUMENTS**

3,546,467	A	12/1970	Benjamin, Jr. et al.	
D283,370	S	* 4/1986	Hill	D3/7
D291,148	S	* 8/1987	Rizzo	D3/7
D349,144	S	* 7/1994	Greene	D21/775
D426,377	S	* 6/2000	Barnes et al.	D3/7
D441,950	S	* 5/2001	Suen	D3/7
D465,914	S	* 11/2002	Hayden et al.	D3/7
D482,192	S	* 11/2003	Lewicki	D3/7
D540,534	S	* 4/2007	Chan	D3/7

D544,201	S	* 6/2007	Berl	D3/12
D555,350	S	* 11/2007	Graves et al.	D3/7
D627,149	S	* 11/2010	Wu	D3/12
D663,942	S	* 7/2012	Martin	D3/7
2006/0028544	A1	2/2006	Tseng	

\* cited by examiner

*Primary Examiner* — John Windmuller

(74) *Attorney, Agent, or Firm* — Richard C. Litman

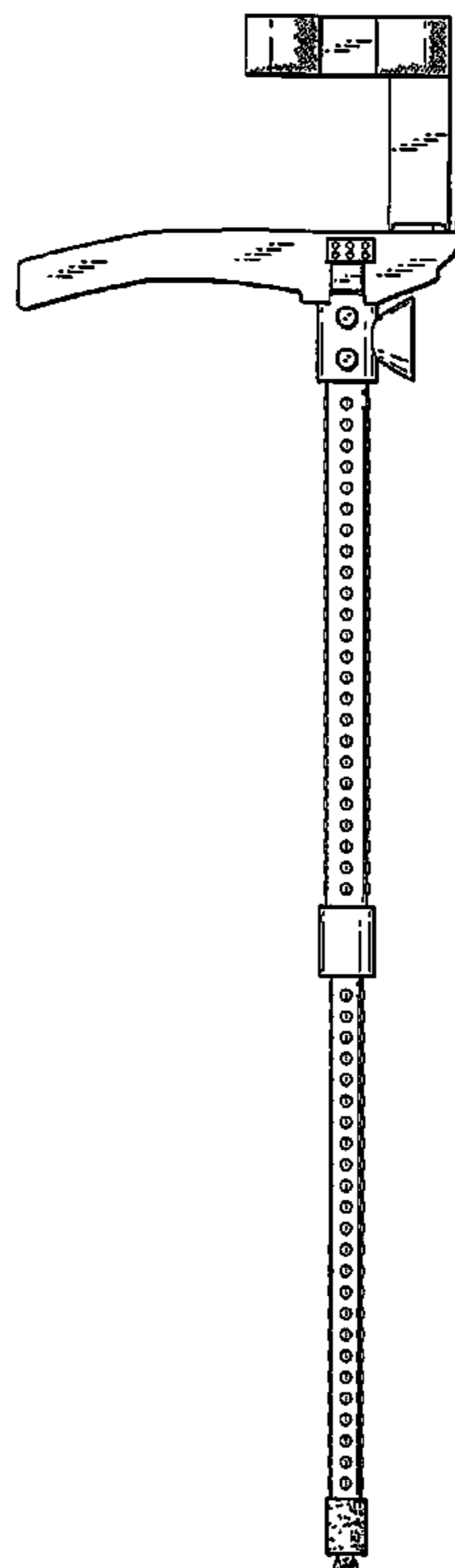
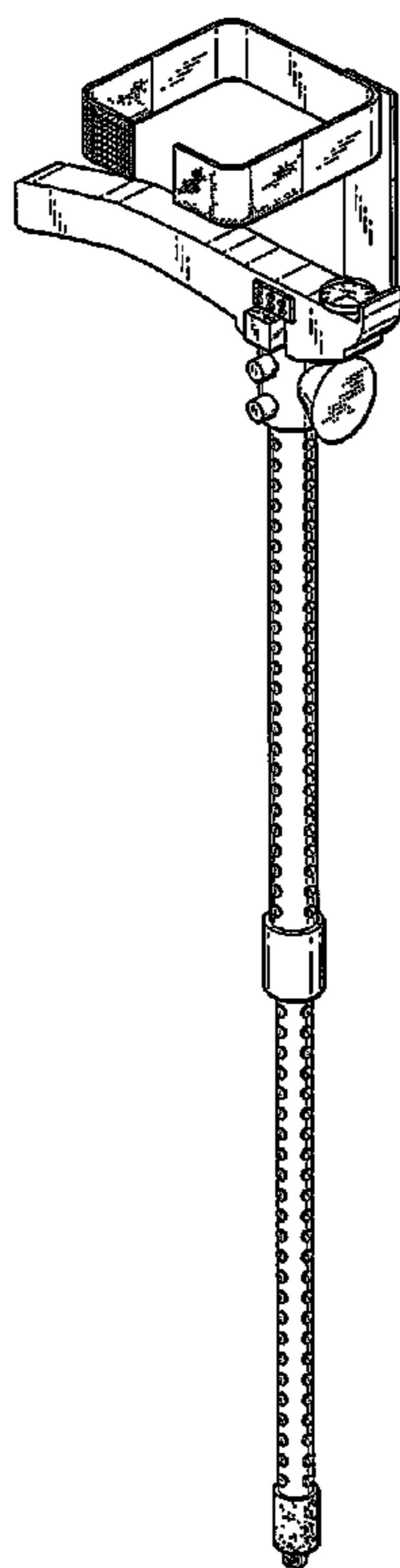
(57) **CLAIM**

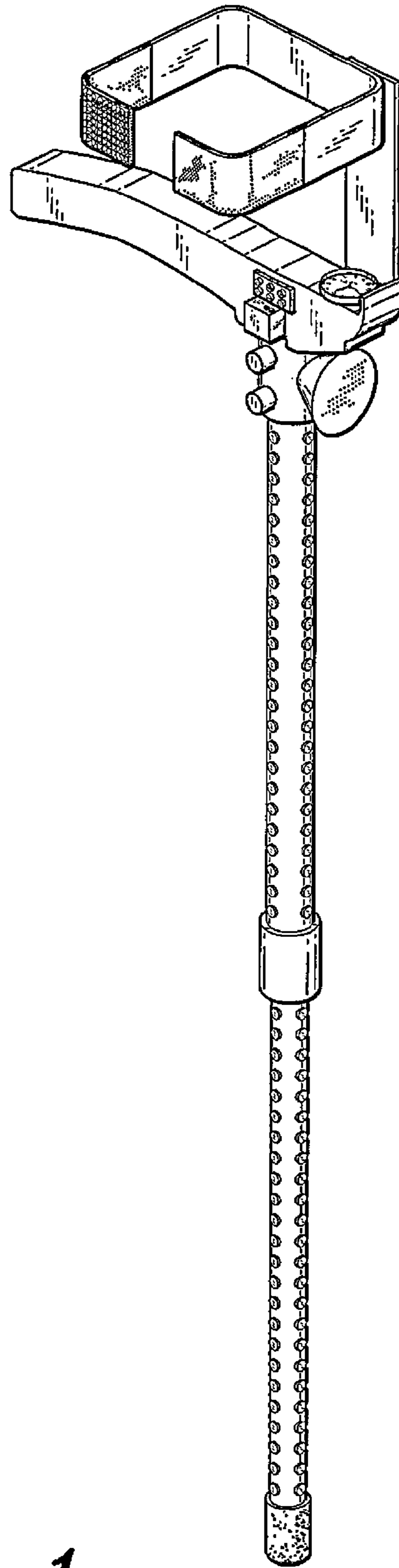
The ornamental design for an electronic cane for the blind, as shown and described.

**DESCRIPTION**

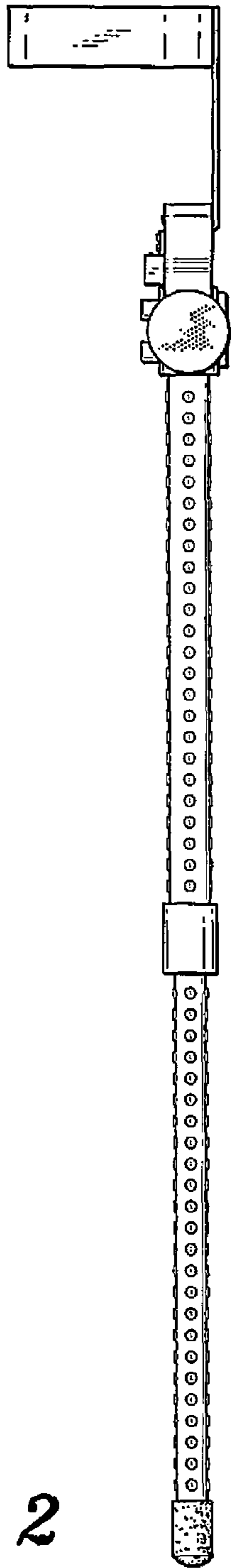
FIG. 1 is a perspective view of a first embodiment of an electronic cane for the blind showing my new design; FIG. 2 is a front elevational view thereof; FIG. 3 is a rear elevational view thereof; FIG. 4 is a left side elevational view thereof; FIG. 5 is a right side elevational view thereof; FIG. 6 is a top plan view thereof; FIG. 7 is a bottom plan view thereof; FIG. 8 is a perspective view of a second embodiment thereof; FIG. 9 is a front elevational view thereof; FIG. 10 is a rear elevational view thereof; FIG. 11 is a left side elevational view thereof; FIG. 12 is a right side elevational view thereof; FIG. 13 is a top plan view thereof; and, FIG. 14 is a bottom plan view thereof.

**1 Claim, 8 Drawing Sheets**

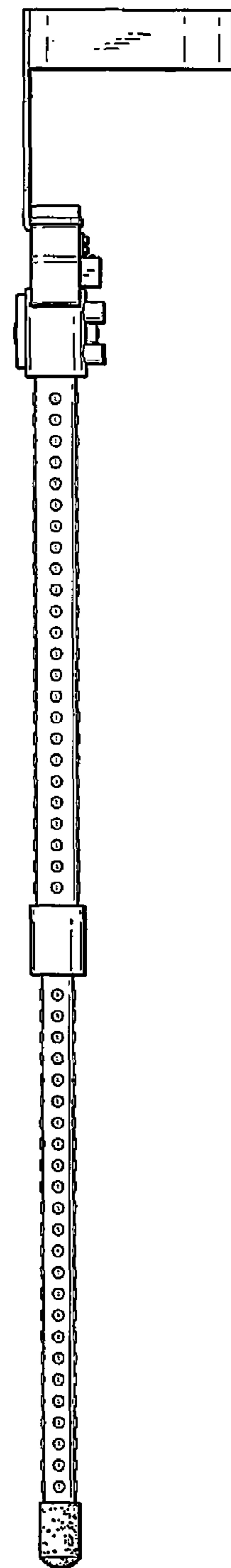




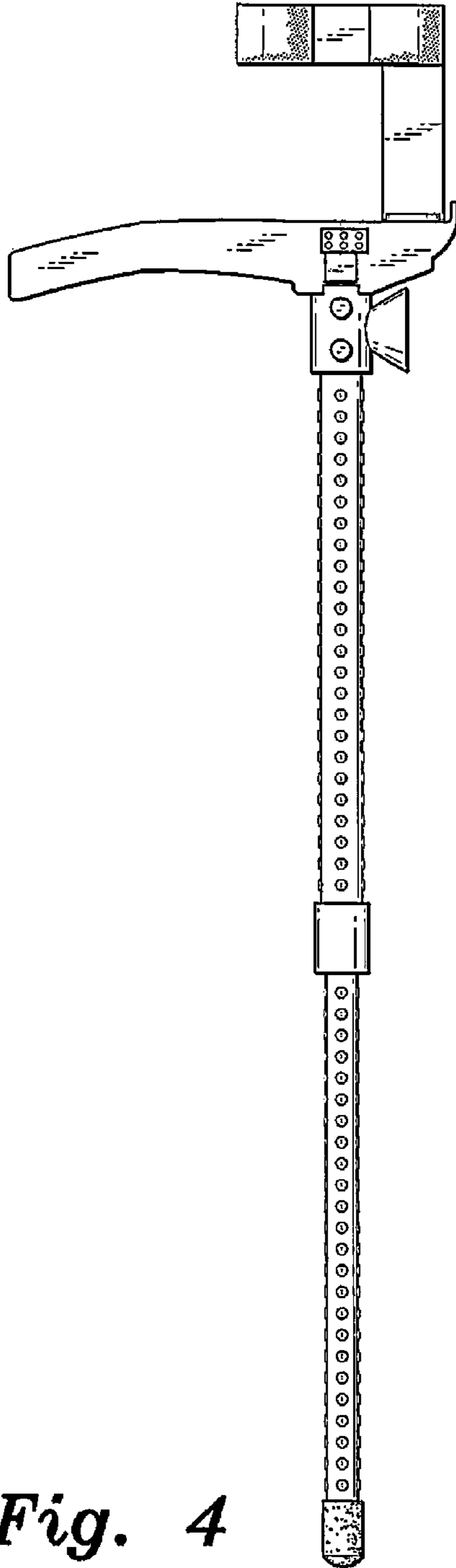
*Fig. 1*



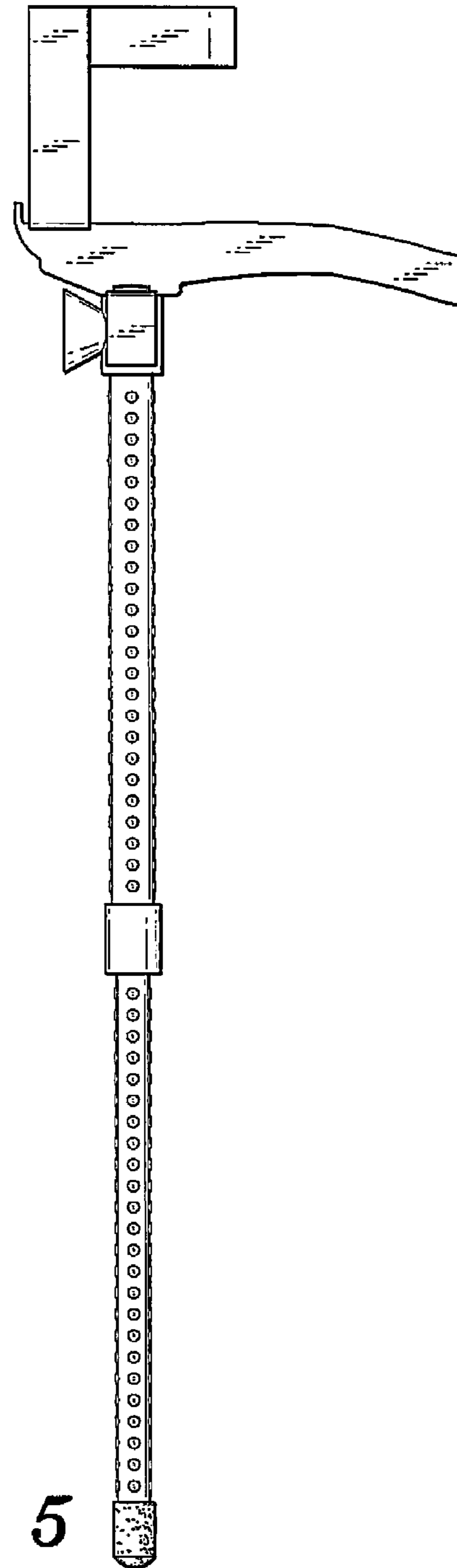
*Fig. 2*



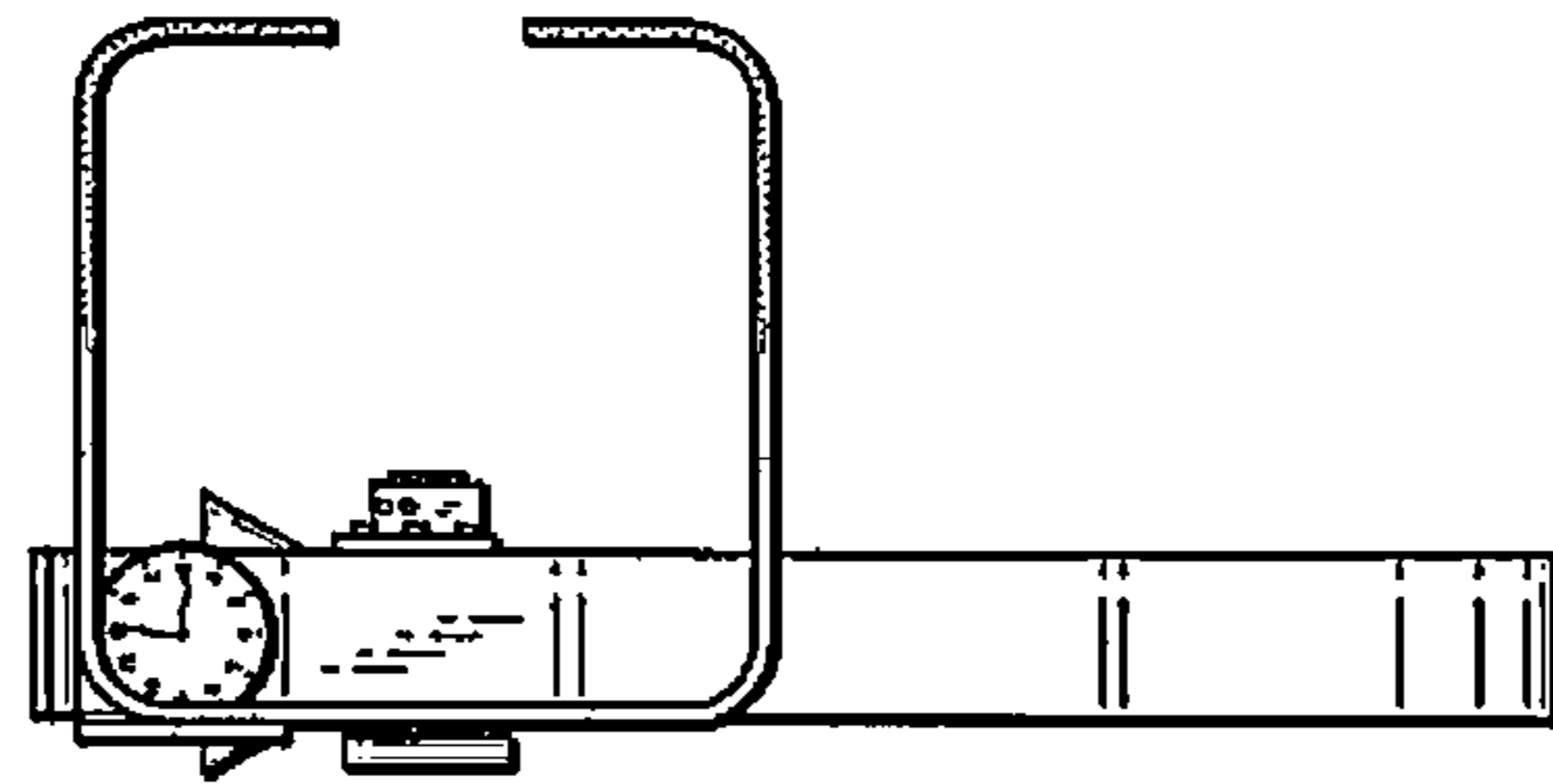
*Fig. 3*



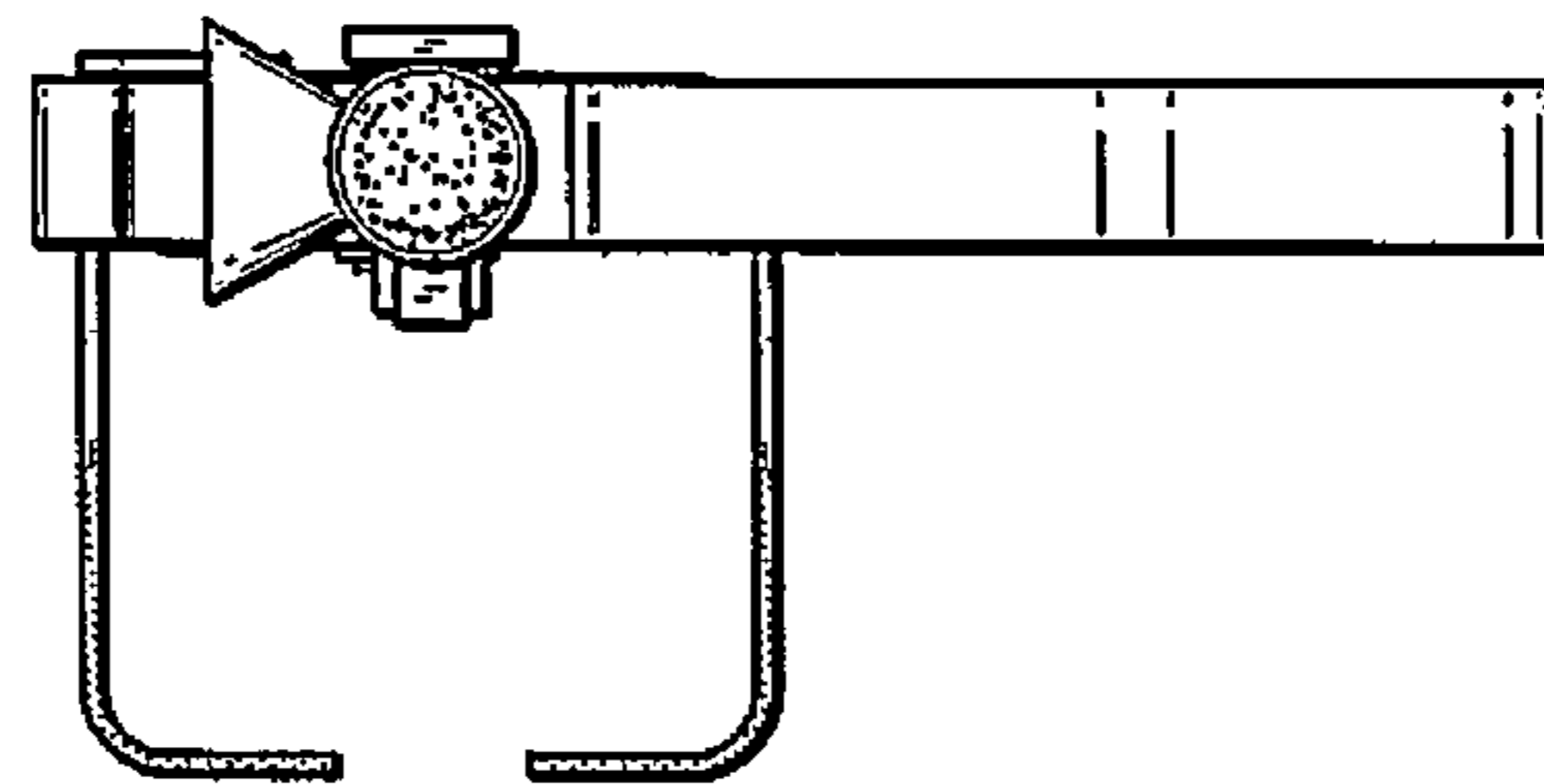
*Fig. 4*



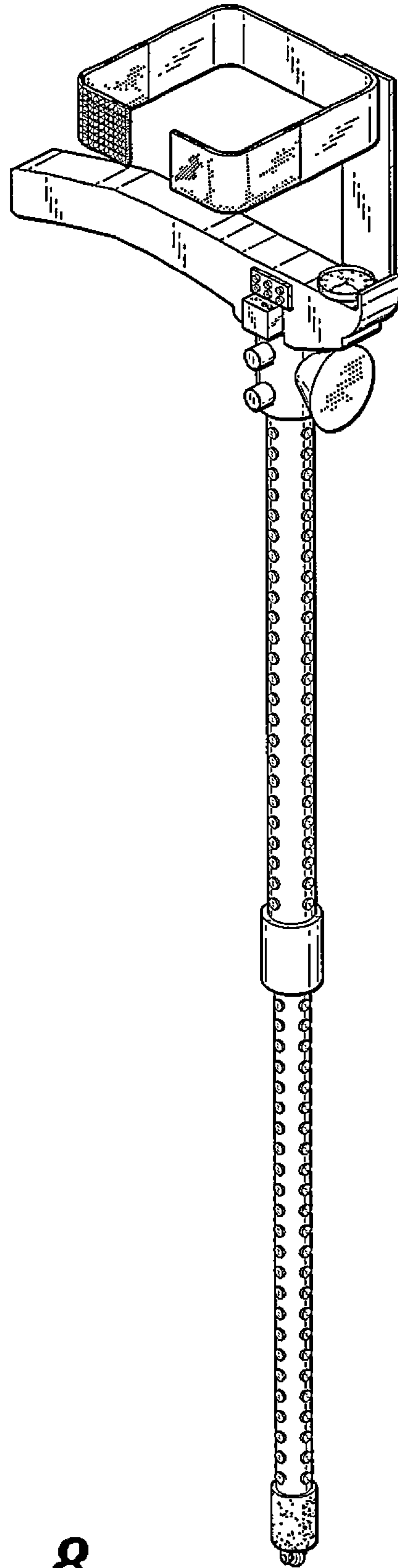
*Fig. 5*



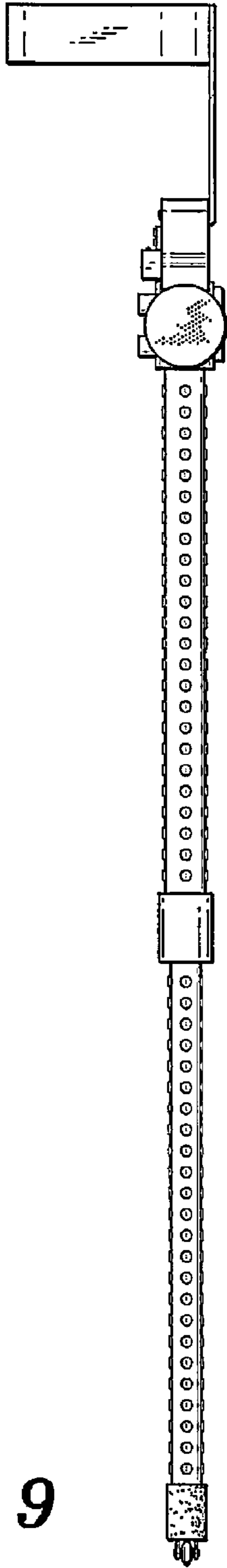
*Fig. 6*



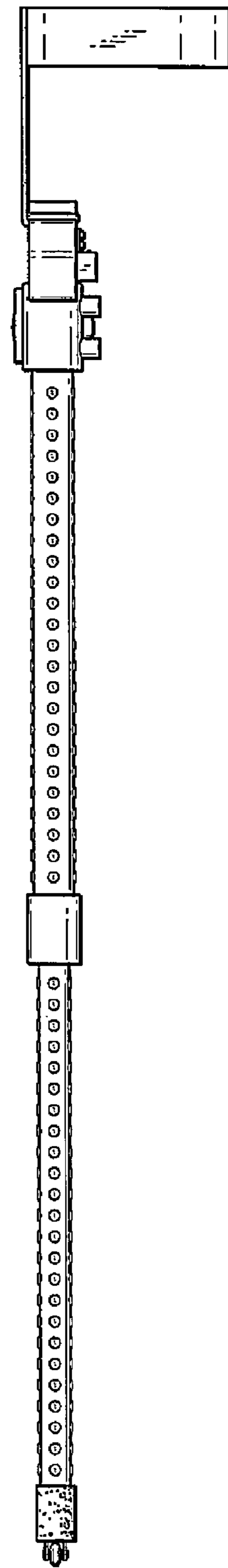
*Fig. 7*



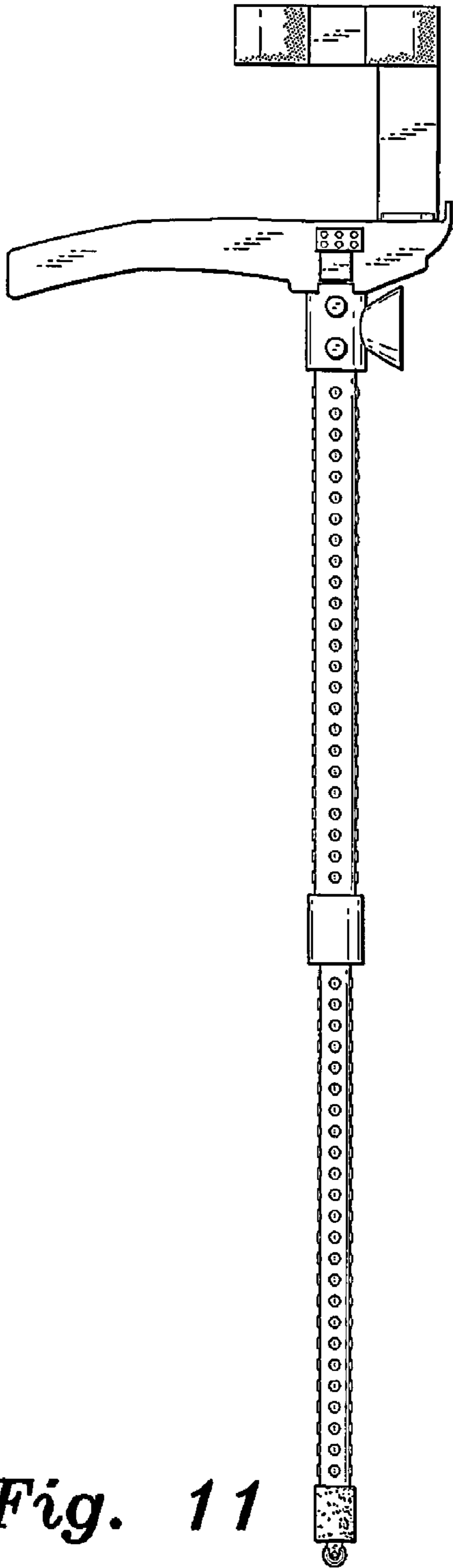
*Fig. 8*



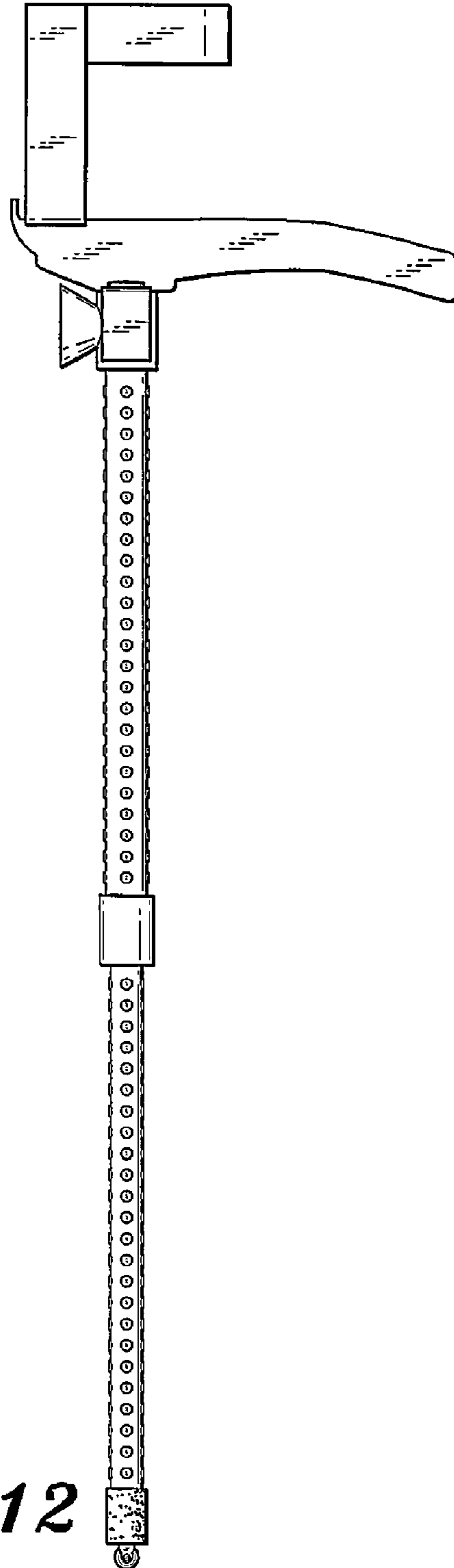
*Fig. 9*



*Fig. 10*

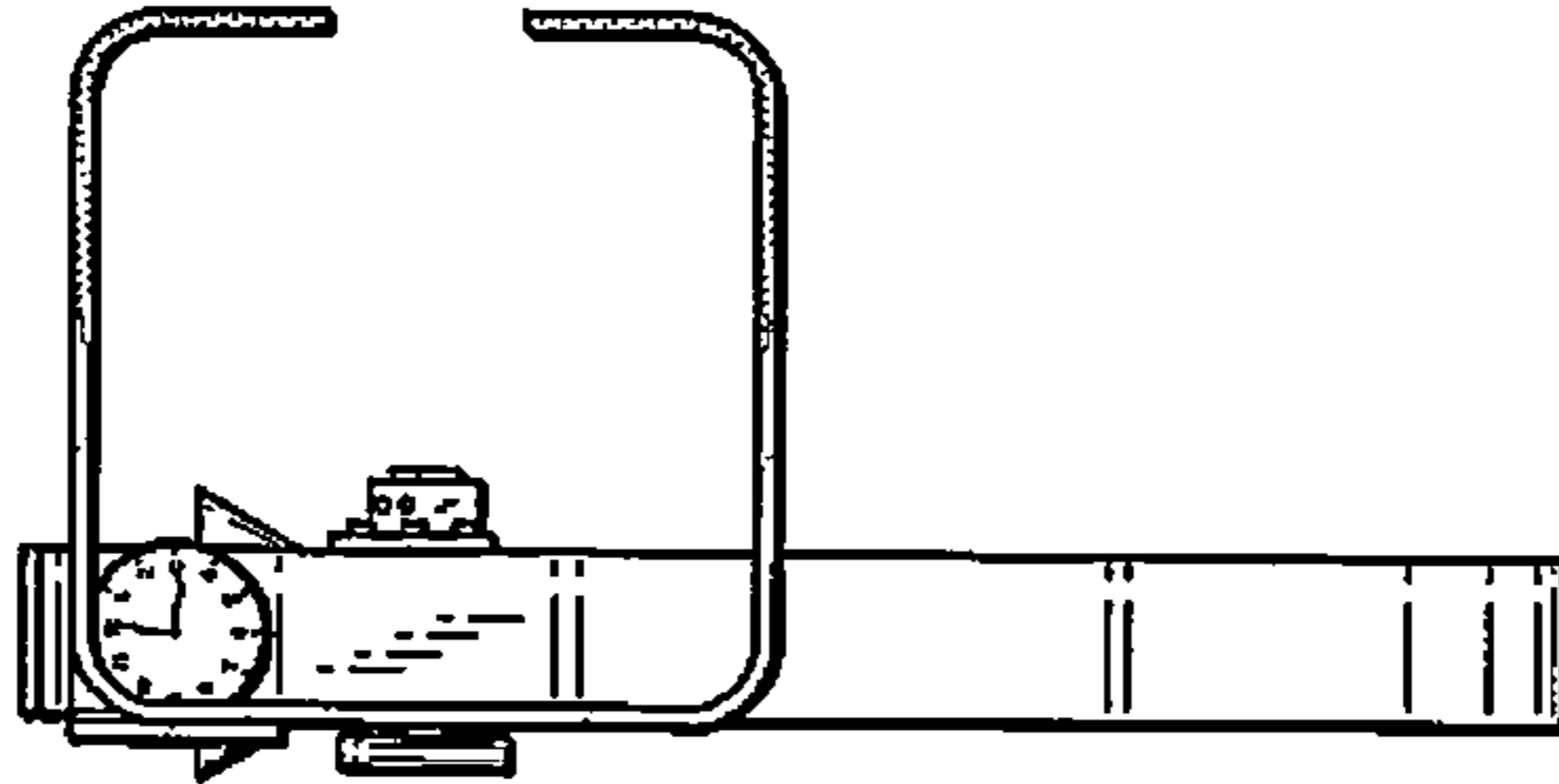


*Fig. 11*

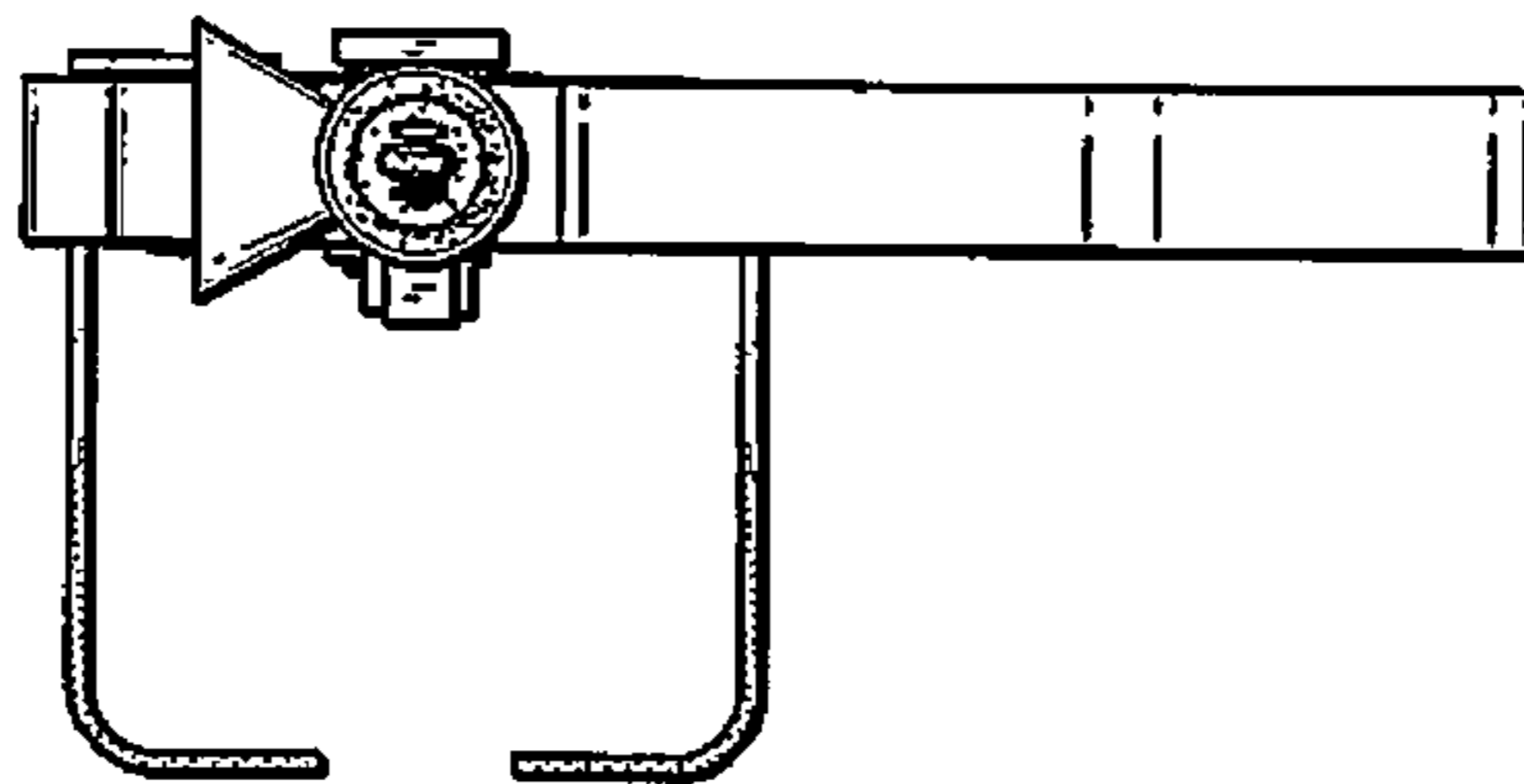


*Fig. 12*





*Fig. 13*



*Fig. 14*