



US00D696985S

(12) **United States Design Patent**
Henstridge

(10) **Patent No.:** **US D696,985 S**
(45) **Date of Patent:** **** Jan. 7, 2014**

(54) **VEHICLE COMPONENT**

(71) Applicant: **Land Rover**, Warwickshire (GB)

(72) Inventor: **Sean Henstridge**, Warwickshire (GB)

(73) Assignee: **Land Rover** (GB)

(**) Term: **14 Years**

(21) Appl. No.: **29/435,133**

(22) Filed: **Oct. 19, 2012**

(30) **Foreign Application Priority Data**

Apr. 19, 2012 (EM) 002029447
Aug. 13, 2012 (EM) 002087189
Aug. 13, 2012 (EM) 002087387

(51) **LOC (10) Cl.** **12-16**

(52) **U.S. Cl.**
USPC **D12/163**

(58) **Field of Classification Search**
USPC D12/86, 90, 91, 92, 163, 169, 196, 171,
D12/216; 180/68.1, 68.6; 296/193.11
See application file for complete search history.

(56) **References Cited**

U.S. PATENT DOCUMENTS

5,487,575 A * 1/1996 Chase 293/115
5,503,444 A * 4/1996 Rouse et al. 293/115
D510,302 S * 10/2005 Sugimoto D12/163
D525,920 S * 8/2006 Toyota D12/163
D536,284 S * 2/2007 Nakamura et al. D12/163
D539,194 S * 3/2007 Moses D12/163
D549,139 S * 8/2007 Pinkney D12/163
D562,740 S * 2/2008 Ogawa et al. D12/163

D572,177 S * 7/2008 Nakamura et al. D12/163
D602,820 S * 10/2009 Yukawa et al. D12/163
D604,209 S * 11/2009 Chae D12/163
7,677,650 B2 * 3/2010 Huttenlocher 296/193.1
D661,230 S * 6/2012 Zheng et al. D12/163

OTHER PUBLICATIONS

2011 Land Rover Range Rover—Model Range. Electronic Brochure. Sep. 1, 2010 [online], [retrieved on Jul. 16, 2013]. Retrieved from the Internet <URL: http://www.auto-brochures.com/makes/landrover/LandRover_US%20Full%20Line_2011.pdf>.*

2013 Land Rover Range Rover. Above and Beyond. Electronic Brochure. Nov. 16, 2012 [online], [retrieved on Jul. 16, 2013]. Retrieved from the Internet <URL: http://www.auto-brochures.com/makes/landrover/Range%20Rover/Land%20Rover_US%20RangeRover_2013.pdf>.*

* cited by examiner

Primary Examiner — Philip S Hyder

Assistant Examiner — Darlington Ly

(74) *Attorney, Agent, or Firm* — Rader, Fishman & Grauer PLLC

(57) **CLAIM**

The ornamental design for a vehicle component, as shown and described.

DESCRIPTION

FIG. 1 is a front perspective view of a vehicle component; FIG. 2 is a rear perspective view thereof; FIG. 3 is a front elevation view thereof; FIG. 4 is a rear view elevation view thereof; FIG. 5 is a left side elevation view thereof; FIG. 6 is a right side elevation view thereof; and, FIG. 7 is a top plan view thereof.

1 Claim, 6 Drawing Sheets

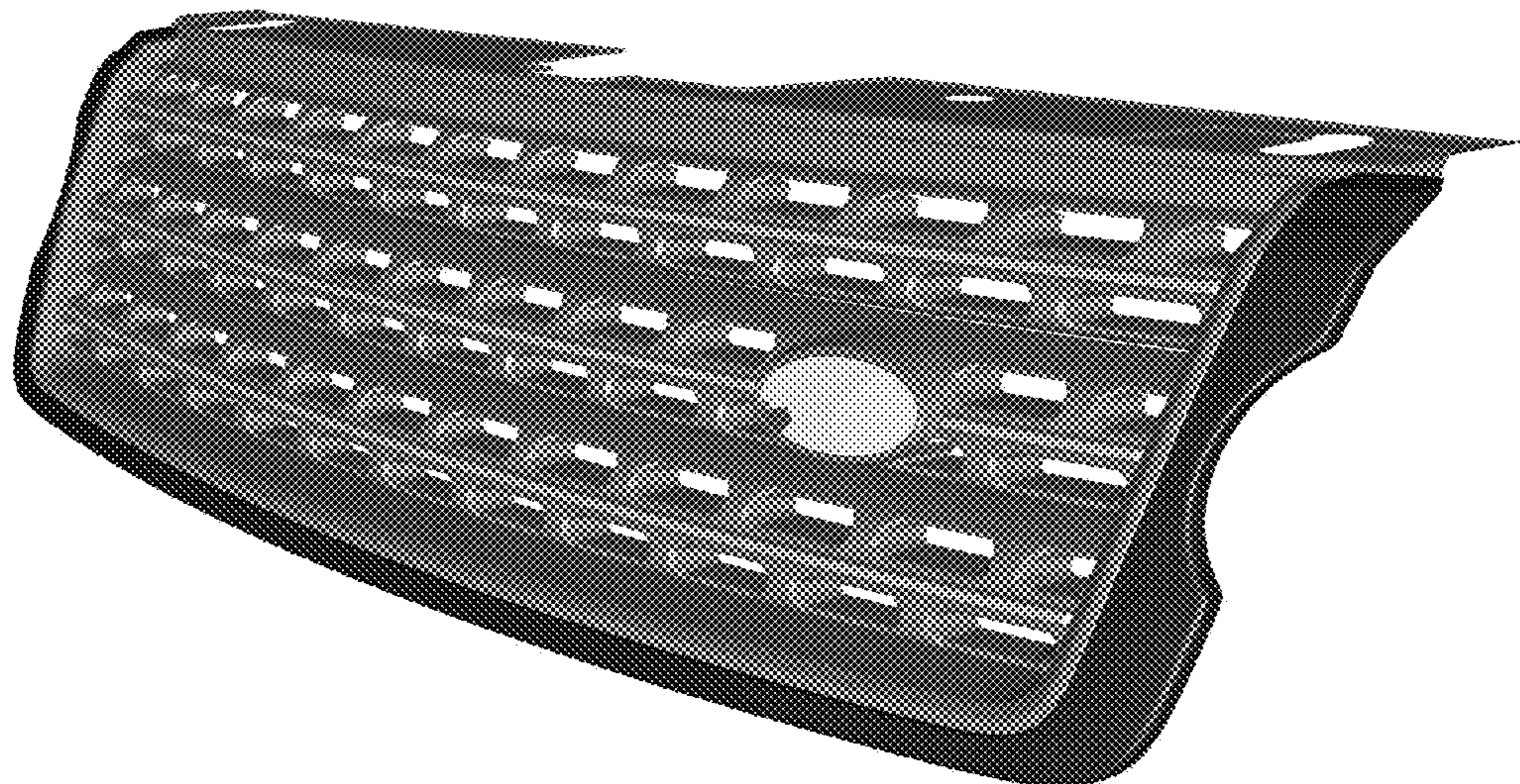

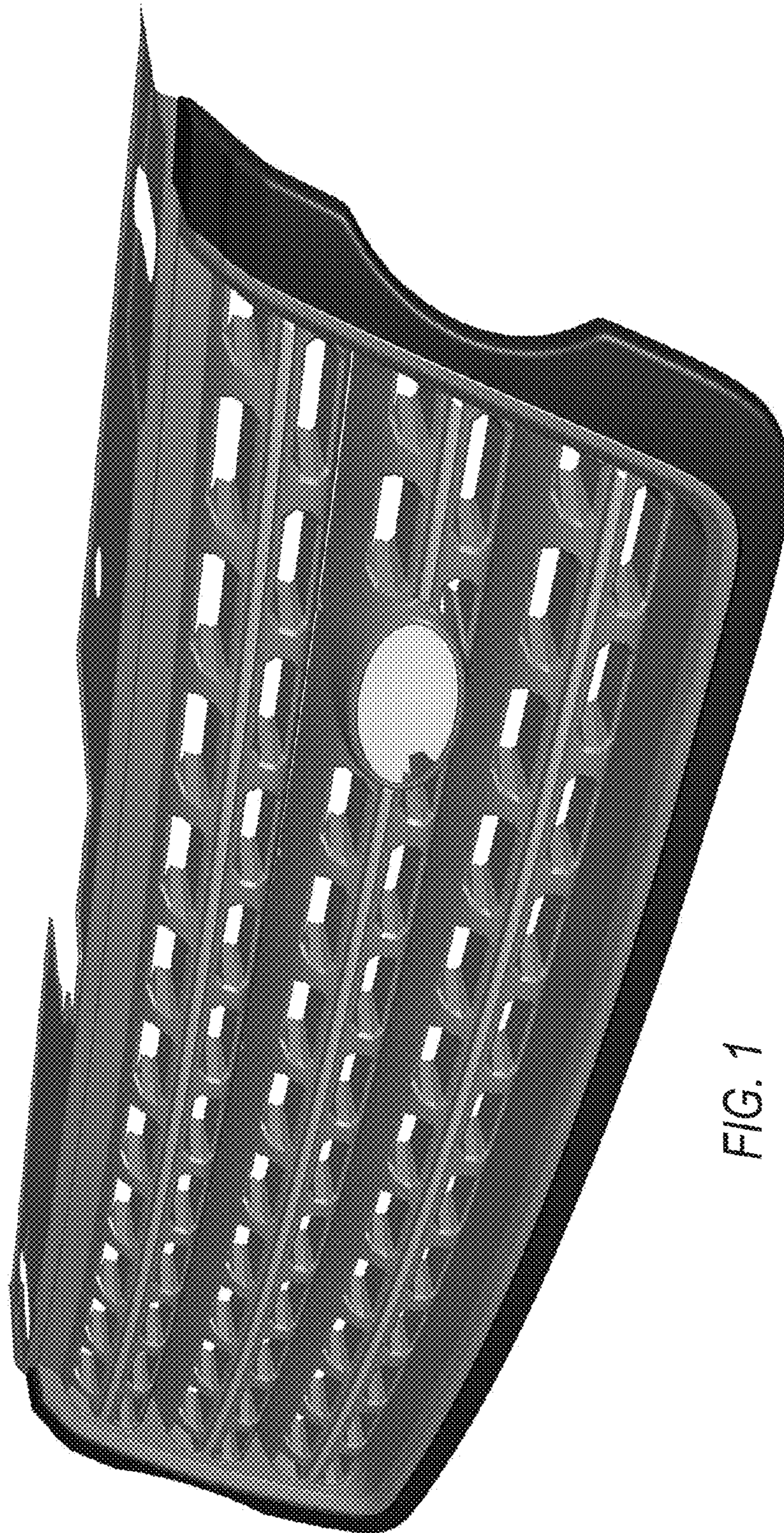

FIG. 1

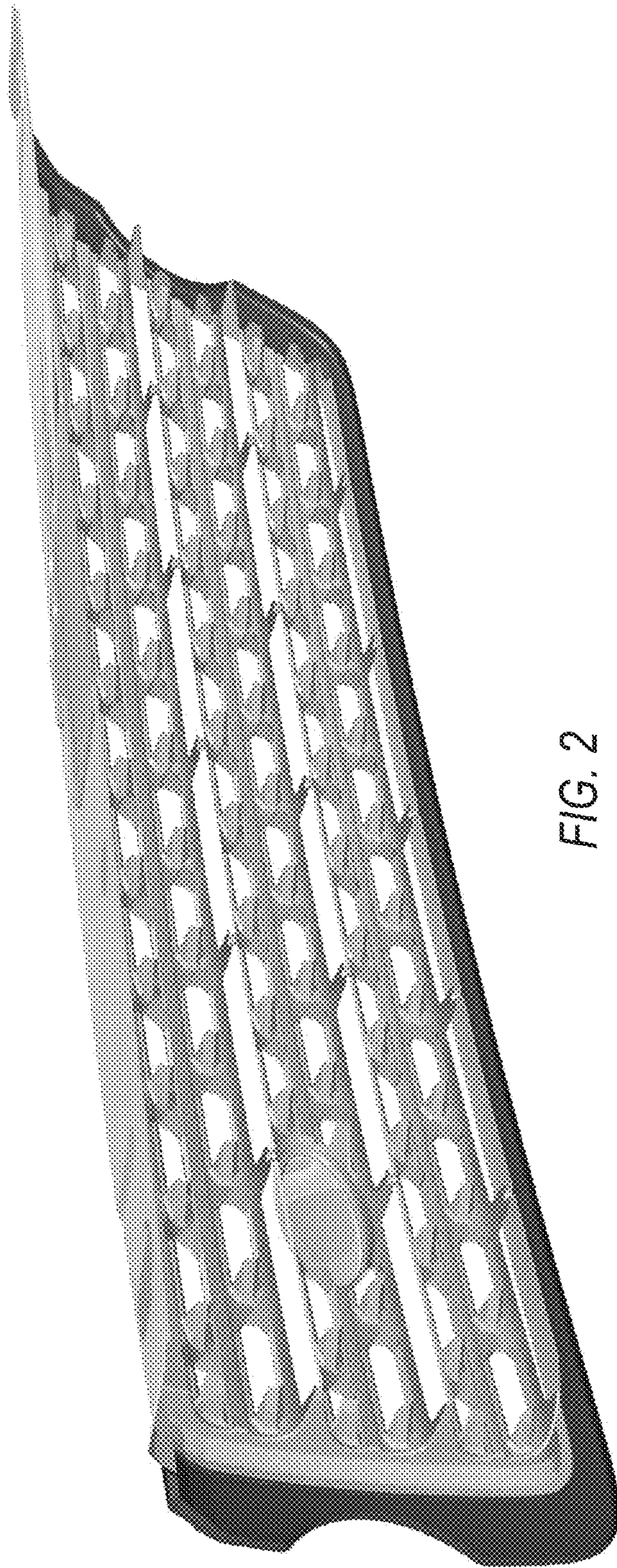

FIG. 2

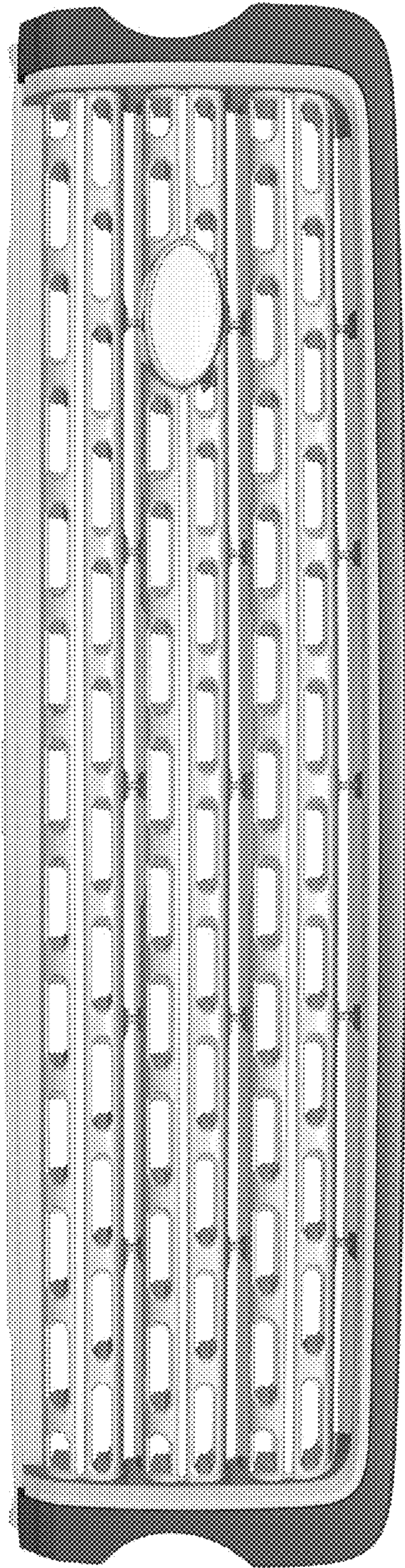

FIG. 3

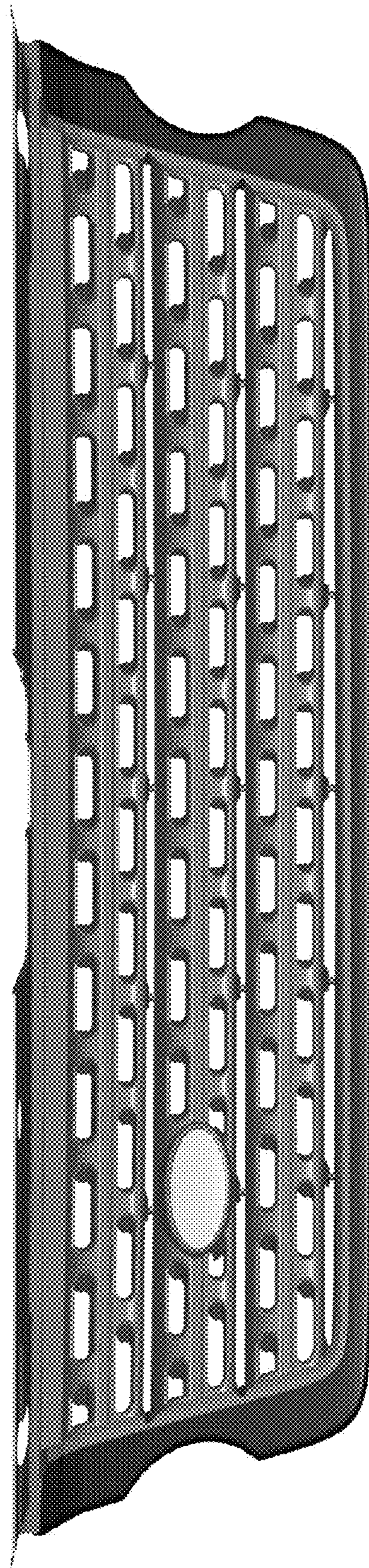

FIG. 4

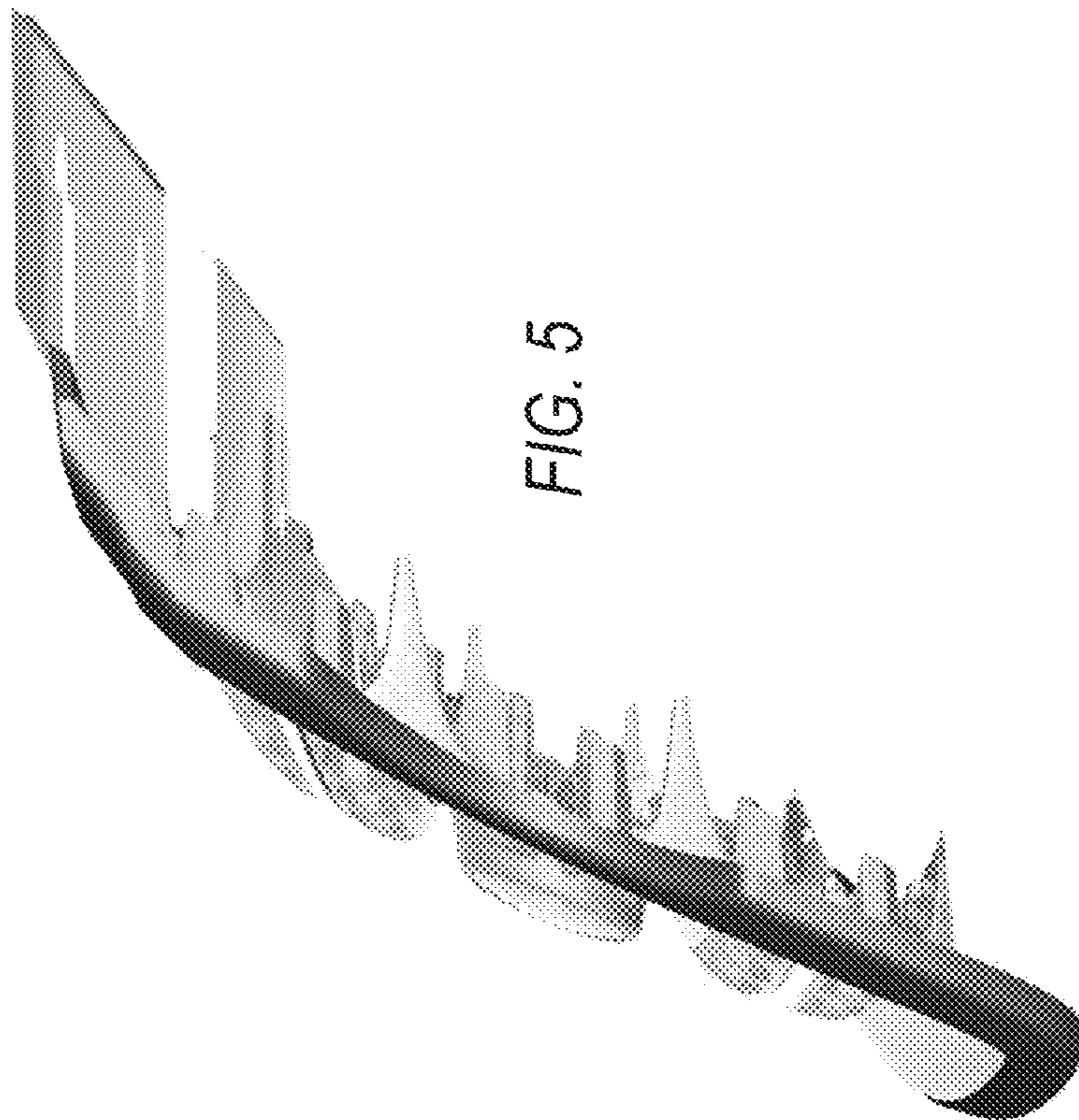

FIG. 5

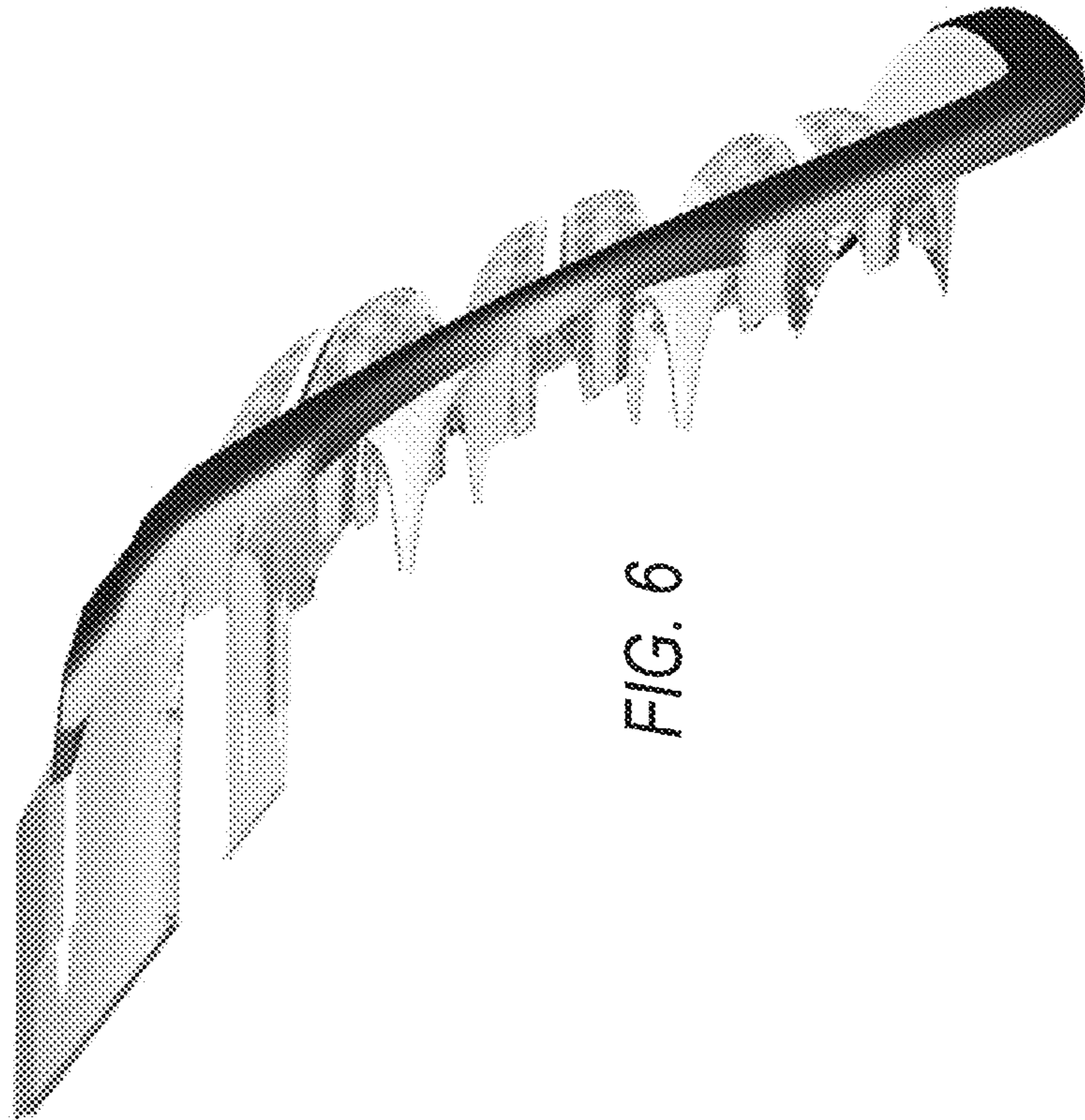

FIG. 6

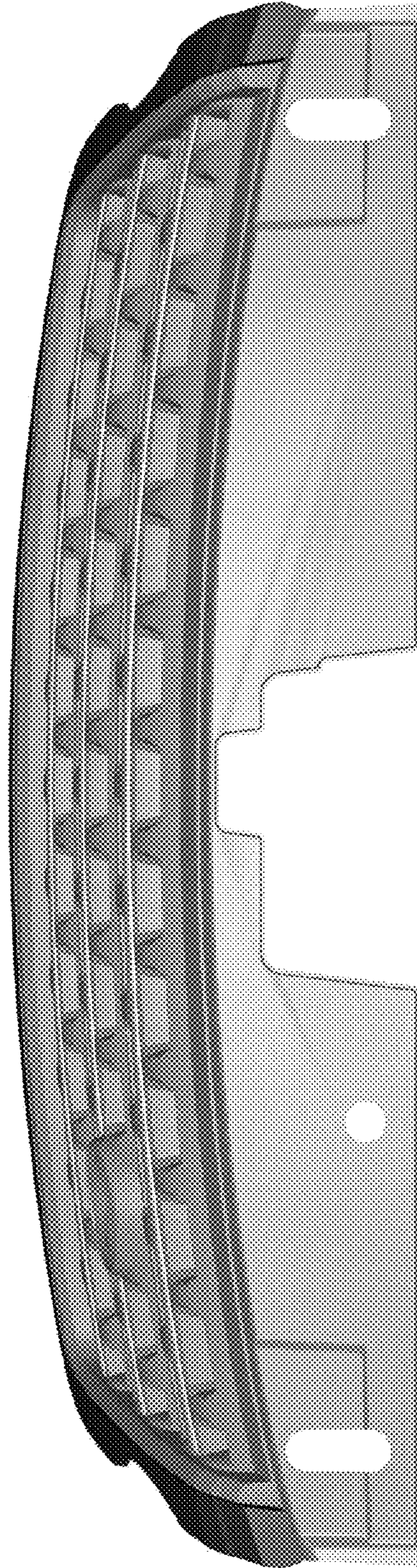

FIG. 7