



US00D696443S

(12) **United States Design Patent**
Ito et al.

(10) **Patent No.:** **US D696,443 S**
(45) **Date of Patent:** **** Dec. 24, 2013**

(54) **HEADLIGHT OF A TRUCK VEHICLE**
(71) Applicant: **International Truck Intellectual Property Company, LLC**, Lisle, IL (US)
(72) Inventors: **Chris Isamu Ito**, Sugar Grove, IL (US); **Glen Joel Durmisevich**, Rochester Hills, MI (US); **John Song**, Palatine, IL (US); **Christian Michael Hardin**, Waterford, MI (US); **Robert Paul Scott**, Aurora, IL (US)

D529,223 S	9/2006	Beigel	
D538,956 S *	3/2007	Ishii	D26/28
D539,947 S	4/2007	Lee	
D544,614 S *	6/2007	Markefka	D26/28
D561,358 S *	2/2008	Tachibana	D26/28
D570,007 S *	5/2008	Hsu	D26/28
D582,587 S *	12/2008	Yang	D26/28
D592,324 S	5/2009	Beigel	
D593,232 S *	5/2009	Koman et al.	D26/28
D635,694 S *	4/2011	Yang et al.	D26/28
D640,826 S	6/2011	Beigel	
D661,011 S	5/2012	Parkes	
D661,012 S	5/2012	Parkes	

* cited by examiner

(73) Assignee: **International Truck Intellect Property Company, LLC**, Lisle, IL (US)

Primary Examiner — Marcus Jackson

(**) Term: **14 Years**

(74) *Attorney, Agent, or Firm* — Jeffrey P. Calfa; Mark C. Bach; Gerald W. Askew

(21) Appl. No.: **29/450,567**

(57) **CLAIM**

(22) Filed: **Mar. 19, 2013**

The ornamental design for a headlight of a truck vehicle, as shown and described.

(51) **LOC (9) Cl.** **26-06**

(52) **U.S. Cl.**
USPC **D26/28**

DESCRIPTION

(58) **Field of Classification Search**
USPC D26/28-36; 362/459-468, 475-478, 362/485-487

See application file for complete search history.

FIG. 1 is a FRONT AND LEFT SIDE PERSPECTIVE view of a left hand embodiment of a headlight of a truck vehicle showing our new design;
FIG. 2 is a FRONT ELEVATION view thereof;
FIG. 3 is a BOTTOM PLAN view thereof;
FIG. 4 is a LEFT SIDE ELEVATION view thereof; and,
FIG. 5 is a TOP PLAN view thereof.

(56) **References Cited**

U.S. PATENT DOCUMENTS

D527,123 S 8/2006 Beigel

1 Claim, 3 Drawing Sheets

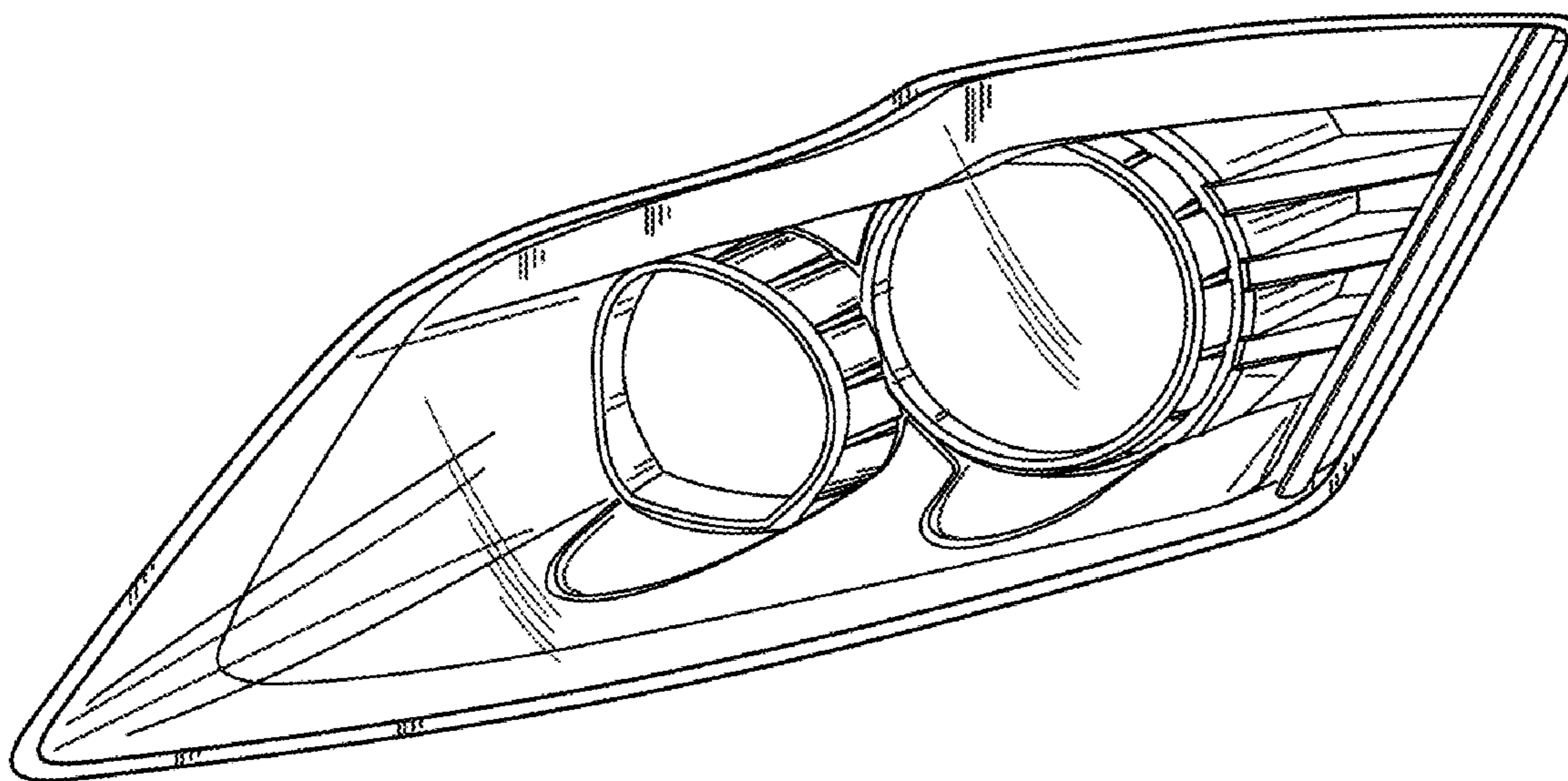

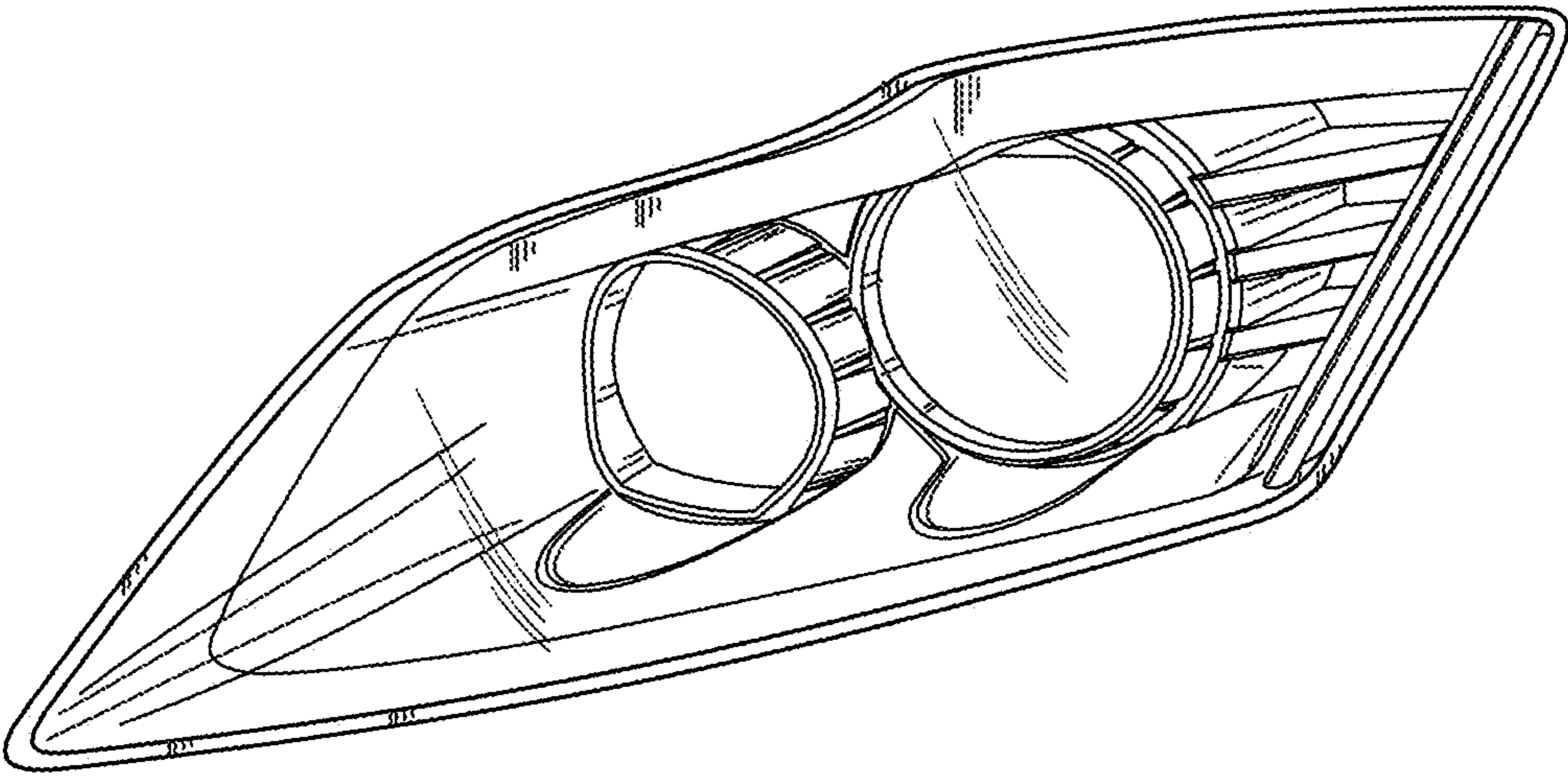

FIG. 1

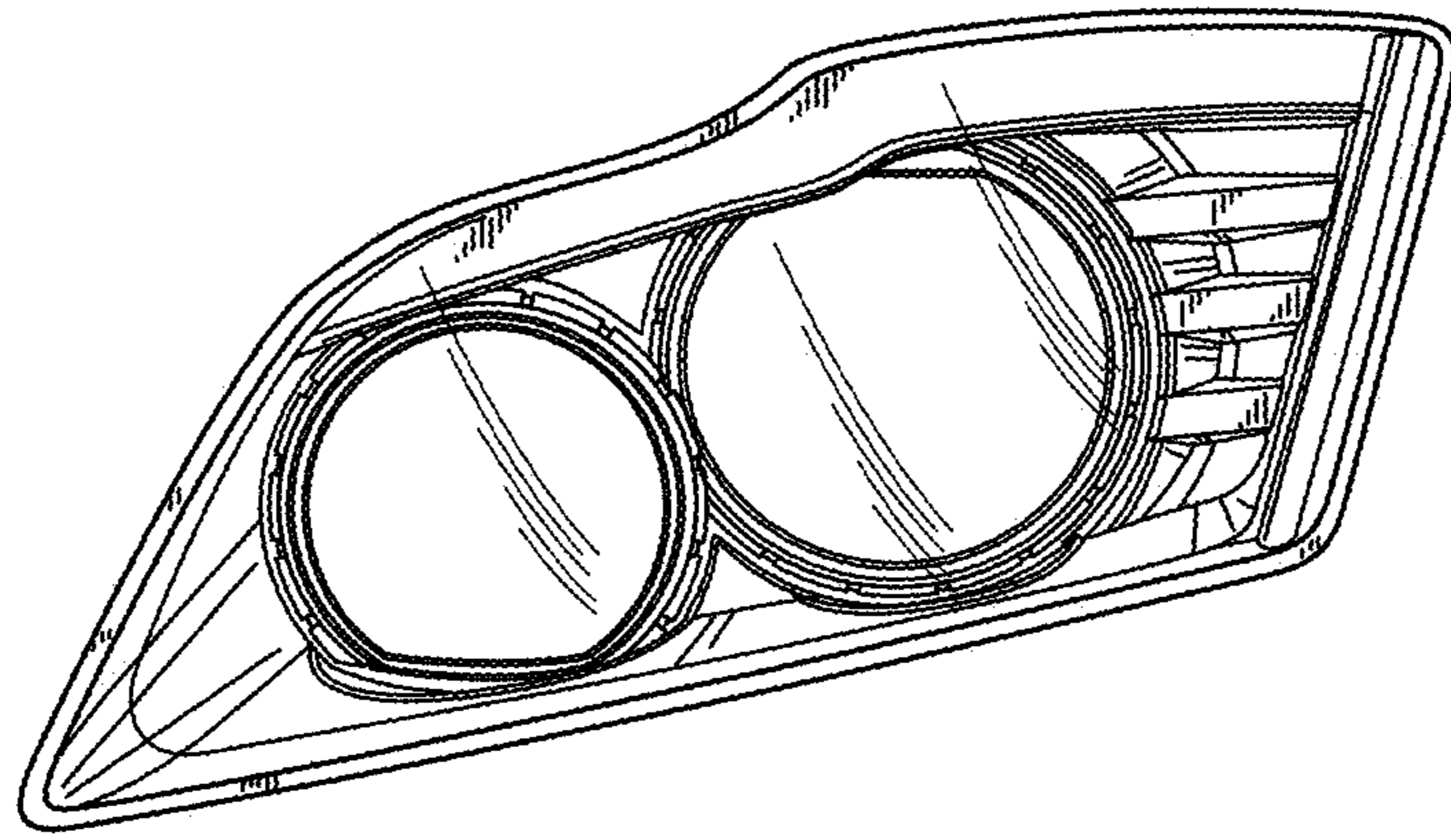

FIG. 2

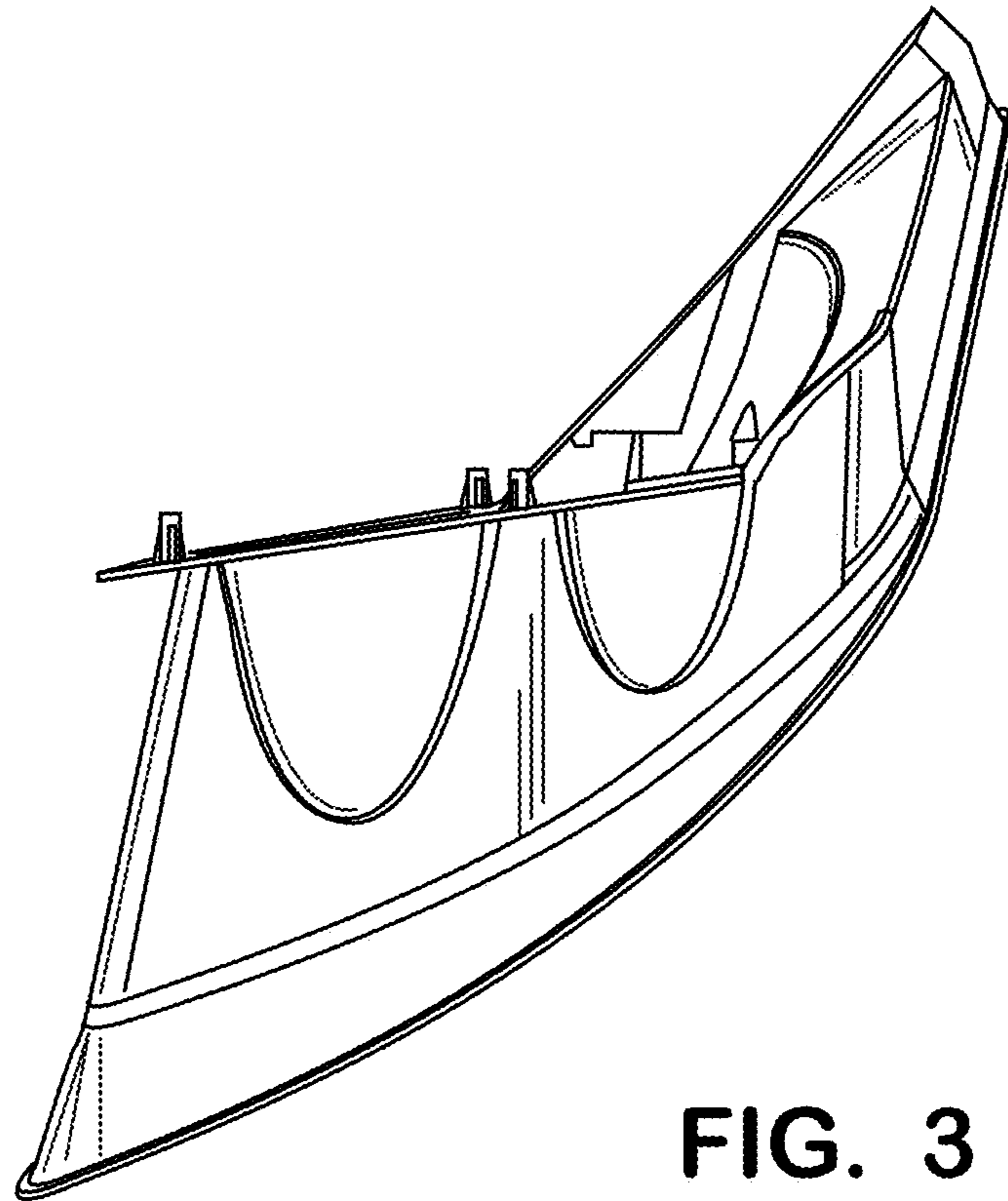

FIG. 3

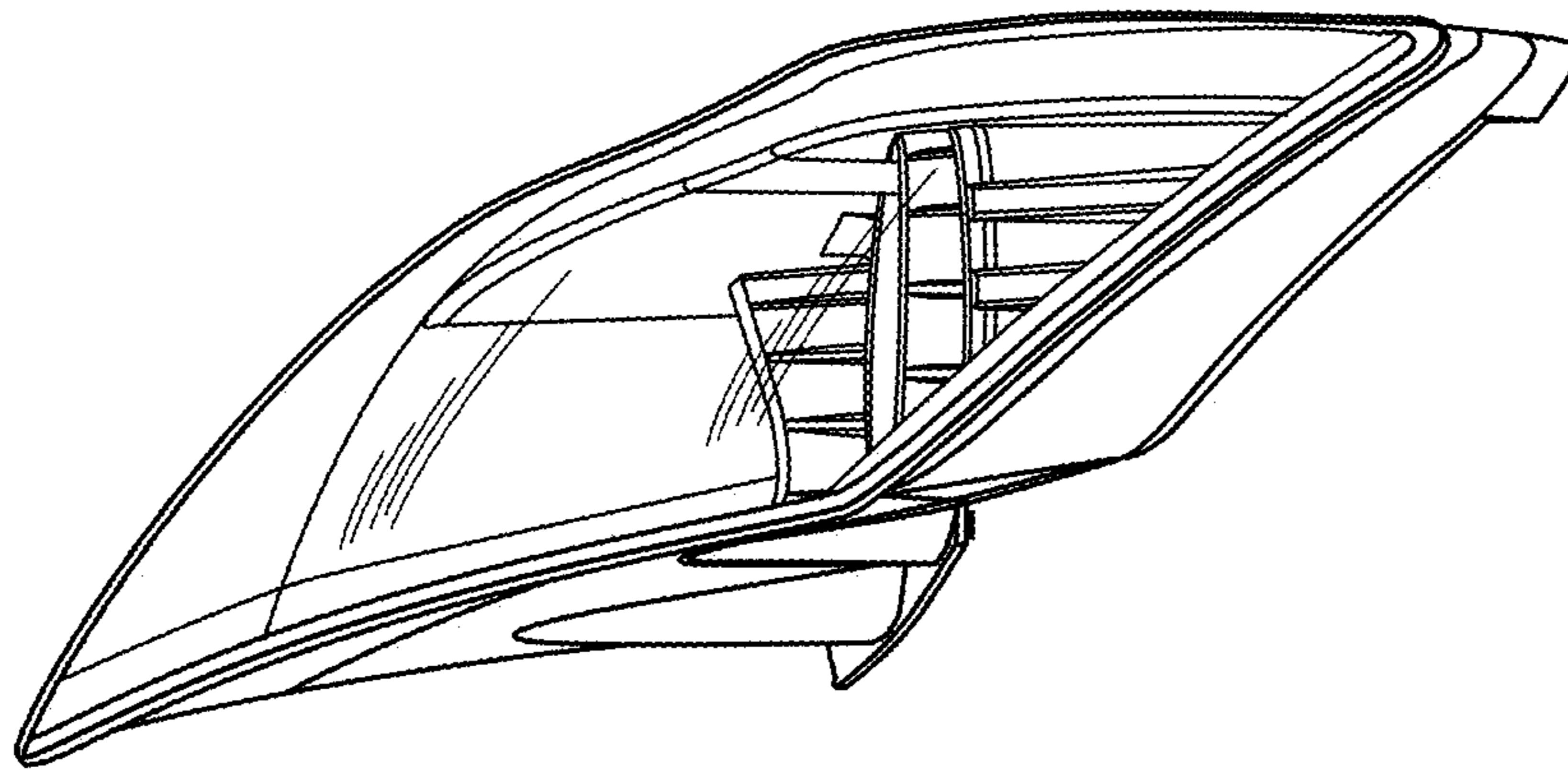

FIG. 4

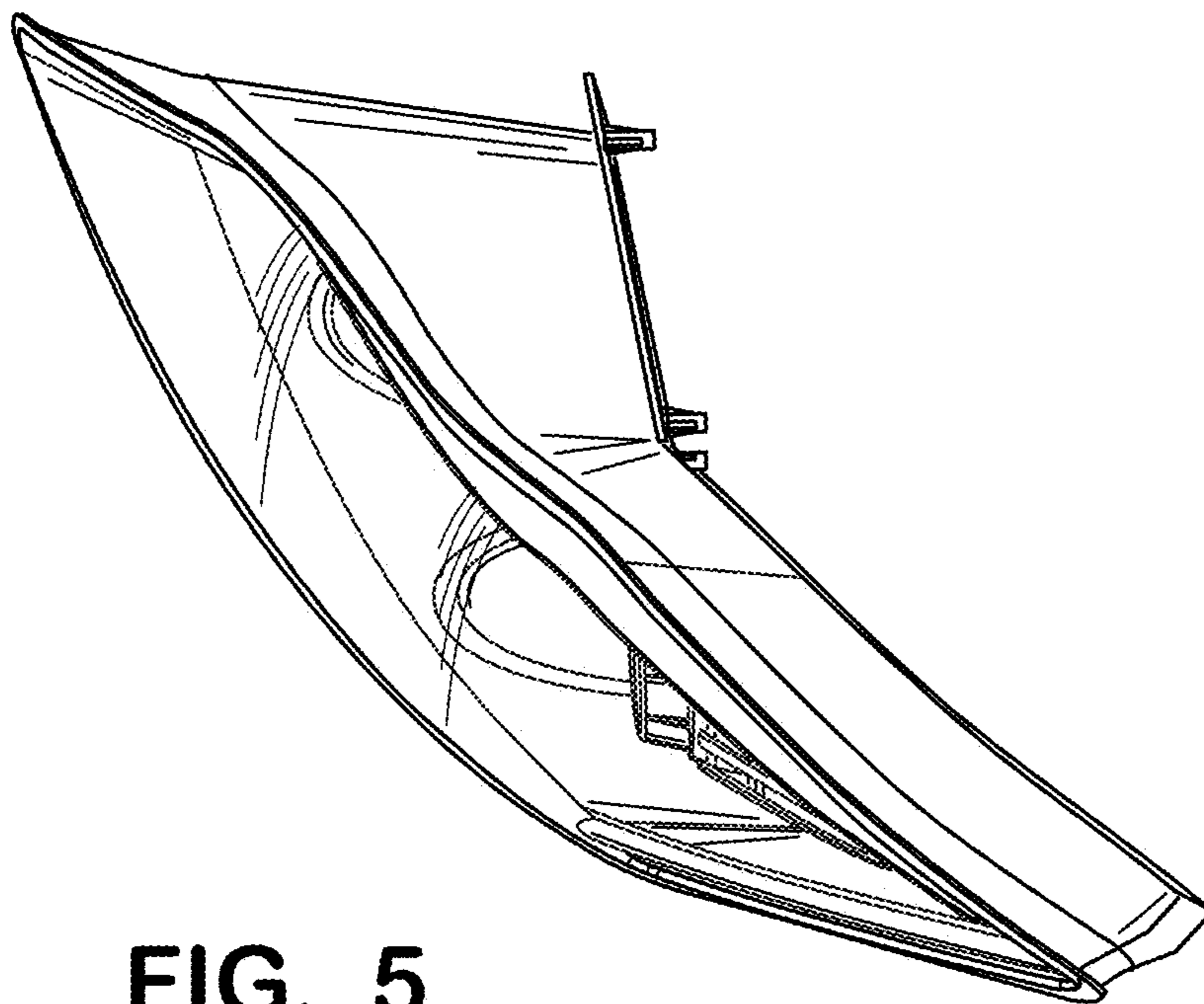

FIG. 5