



US00D695666S

(12) **United States Design Patent**  
**Chung**

(10) **Patent No.:** **US D695,666 S**

(45) **Date of Patent:** **\*\* Dec. 17, 2013**

(54) **WHEEL**

(71) Applicant: **Wheel Pros, LLC**, Lakewood, CO (US)

(72) Inventor: **Suny Chung**, Yorba Linda, CA (US)

(73) Assignee: **Wheel Pros, LLC**, Greenwood Village,  
CO (US)

(\*\*) Term: **14 Years**

(21) Appl. No.: **29/439,744**

(22) Filed: **Dec. 14, 2012**

**Related U.S. Application Data**

(62) Division of application No. 29/435,797, filed on Oct.  
29, 2012.

(51) **LOC (9) Cl.** ..... **12-16**

(52) **U.S. Cl.**  
USPC ..... **D12/209**

(58) **Field of Classification Search**  
USPC ..... D12/204–213; 301/37.101, 64.101, 65,  
301/64.201

See application file for complete search history.

(56) **References Cited**

U.S. PATENT DOCUMENTS

D380,724	S	*	7/1997	Brown et al.	.....	D12/209
D398,278	S	*	9/1998	Brown et al.	.....	D12/211
D446,762	S	*	8/2001	Hussaini et al.	.....	D12/209
D516,488	S	*	3/2006	Truebsbach	.....	D12/209
D523,800	S	*	6/2006	Sulahian	.....	D12/209
D547,251	S	*	7/2007	Baum	.....	D12/209
D571,274	S	*	6/2008	Chung	.....	D12/209
D584,673	S	*	1/2009	Chung	.....	D12/209
D585,806	S	*	2/2009	Chung	.....	D12/209
D642,105	S	*	7/2011	Chung	.....	D12/209
D643,355	S	*	8/2011	Truebsbach	.....	D12/209
D649,921	S	*	12/2011	Lucaora	.....	D12/209
D652,362	S	*	1/2012	Lucaora	.....	D12/209
D686,961	S	*	7/2013	Chung	.....	D12/209
D688,186	S	*	8/2013	McMath	.....	D12/209

\* cited by examiner

*Primary Examiner* — Stacia Cadmus

(74) *Attorney, Agent, or Firm* — Garcia-Zamor IP Law; Ruy  
M. Garcia-Zamor

(57) **CLAIM**

The ornamental design for a wheel, as shown and described.

**DESCRIPTION**

FIG. 1 is a perspective view of a wheel, showing my new  
design; and,  
FIG. 2 is a front view thereof.

**1 Claim, 2 Drawing Sheets**

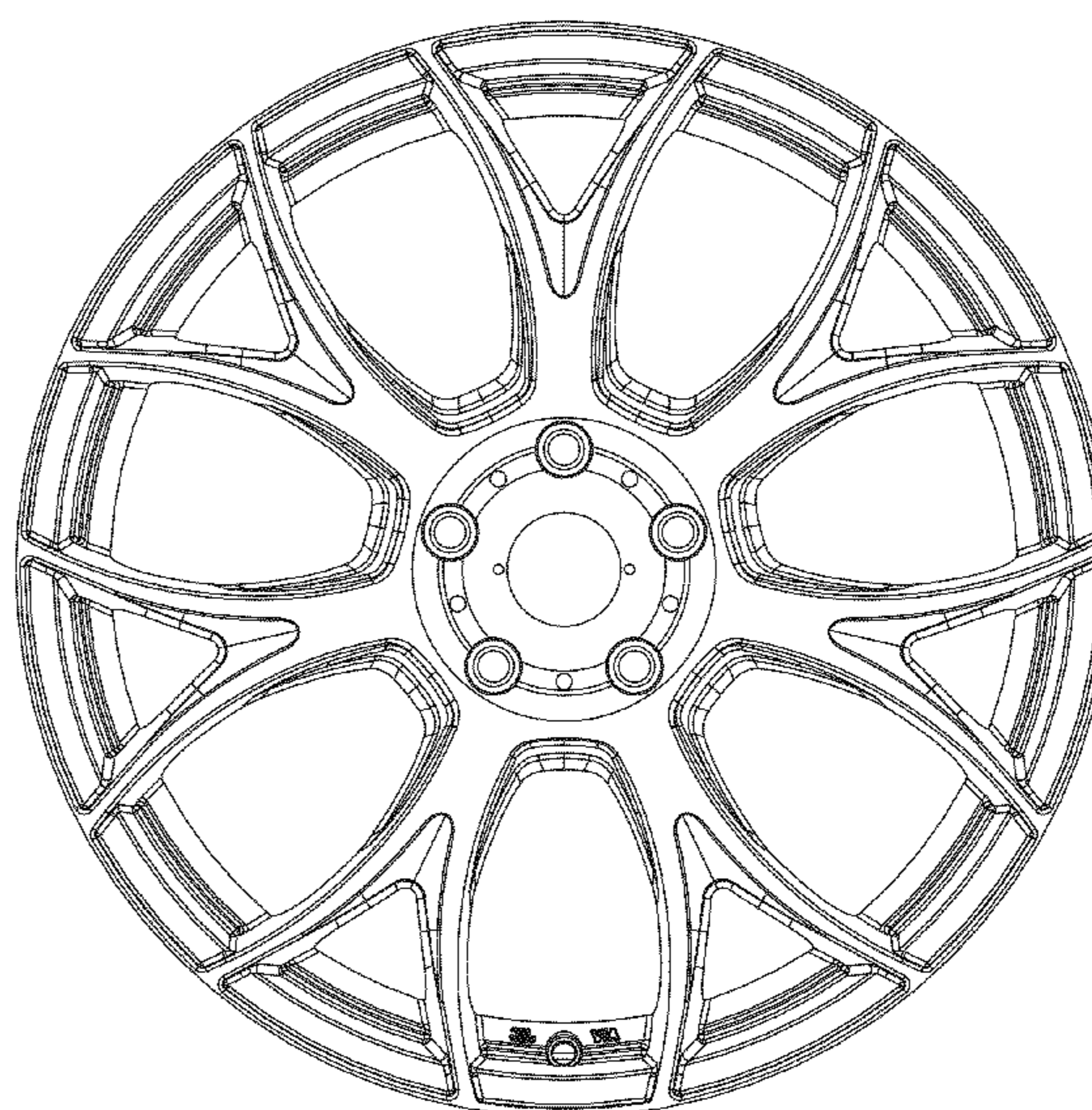
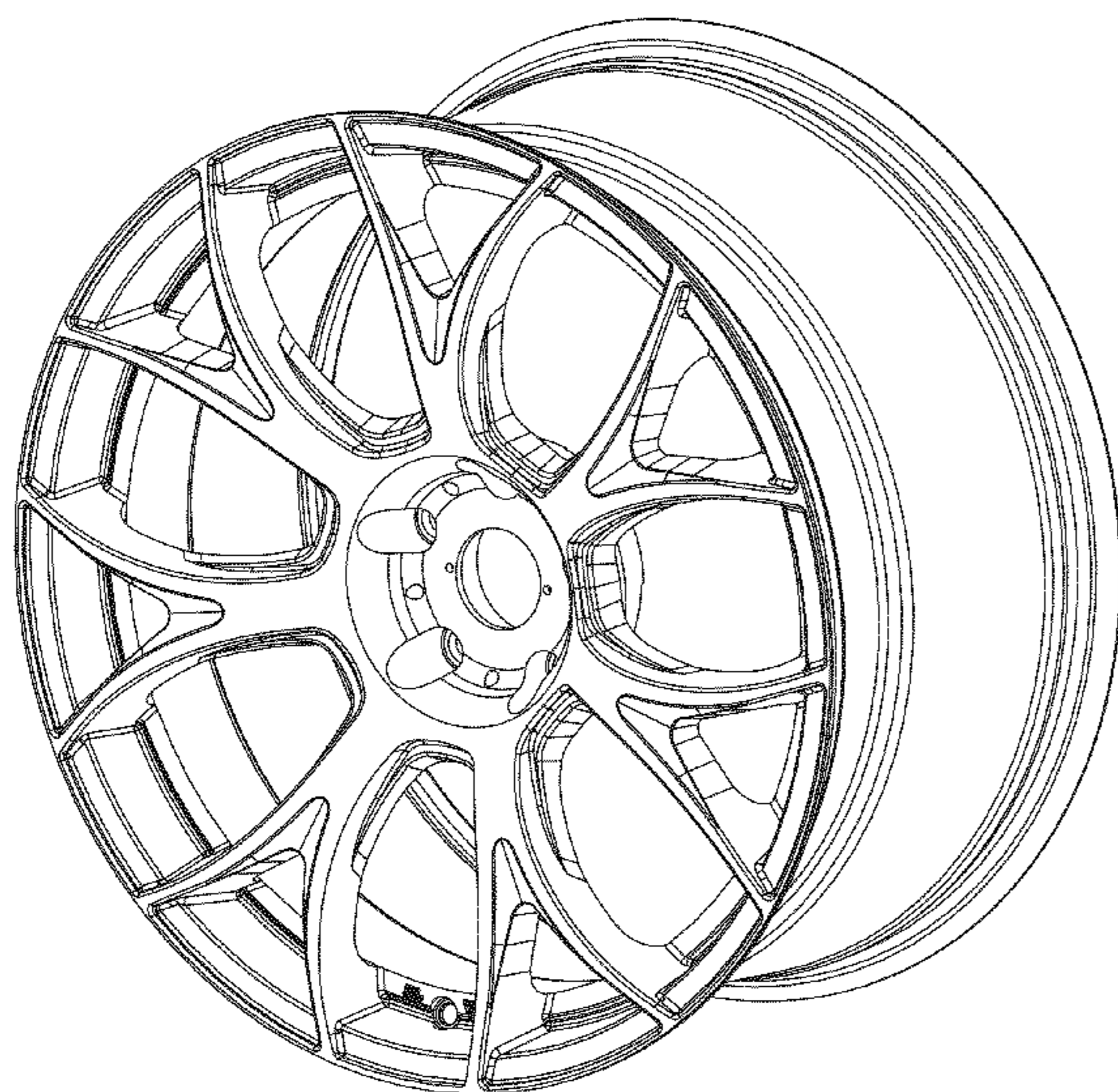



Fig. 1

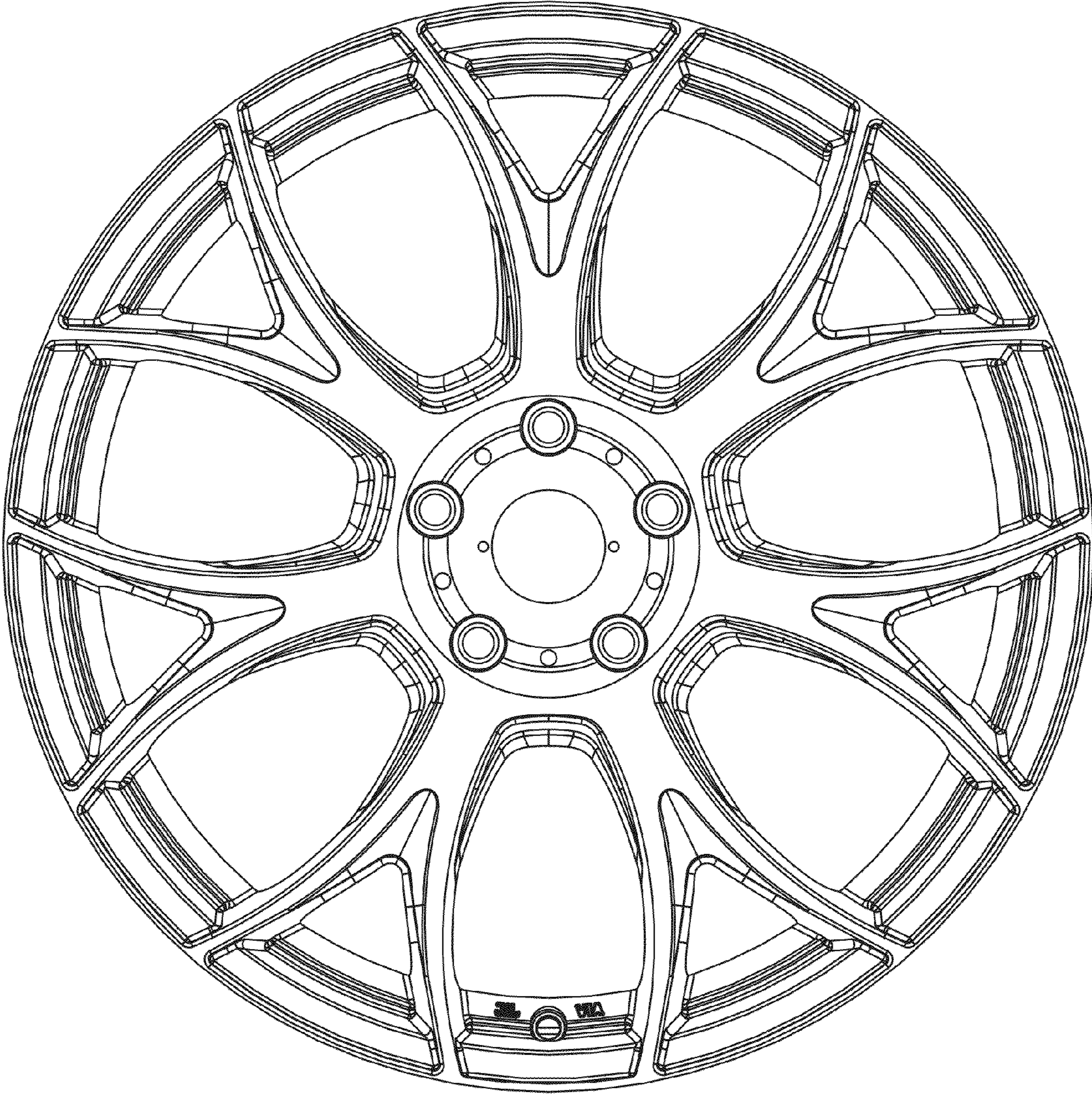

Fig. 2