



US00D695397S

(12) **United States Design Patent**
Nakatsuka et al.

(10) **Patent No.:** **US D695,397 S**
(45) **Date of Patent:** **** Dec. 10, 2013**

(54) **CARTRIDGE CASING FOR SAMPLE COLLECTOR**

(71) Applicant: **Hitachi Plant Technologies, Ltd.**,
Tokyo (JP)

(72) Inventors: **Yuta Nakatsuka**, Tokyo (JP); **Shuichi Mori**, Tokyo (JP); **Koji Seo**, Ibaraki (JP); **Noe Miyashita**, Chiba (JP)

(73) Assignee: **Hitachi, Ltd.**, Tokyo (JP)

(**) Term: **14 Years**

(21) Appl. No.: **29/443,099**

(22) Filed: **Jan. 14, 2013**

(30) **Foreign Application Priority Data**

Jul. 18, 2012 (JP) 2012-017065

(51) **LOC (9) Cl.** **24-02**

(52) **U.S. Cl.**
USPC **D24/127**

(58) **Field of Classification Search**
USPC D24/127, 121, 123, 224, 216;
604/317-325; 422/500, 547, 554
See application file for complete search history.

(56) **References Cited**

U.S. PATENT DOCUMENTS

- 4,956,148 A * 9/1990 Grandone 422/64
- D433,130 S * 10/2000 Cude et al. D24/121
- D495,050 S * 8/2004 Guala D24/108
- 6,875,205 B2 * 4/2005 Leinsing 604/412
- D565,728 S * 4/2008 Jones D24/108
- D612,513 S * 3/2010 Hendricks et al. D24/108

- D616,092 S * 5/2010 Domkowski et al. D24/129
- D630,732 S * 1/2011 Lev et al. D24/129
- D659,254 S * 5/2012 Miyashita et al. D24/216
- D675,729 S * 2/2013 Wang D24/108
- D681,230 S * 4/2013 Mosler et al. D24/231
- 8,449,844 B2 * 5/2013 Wilkinson et al. 422/550
- D686,339 S * 7/2013 Shima et al. D24/224

FOREIGN PATENT DOCUMENTS

JP 1399500 10/2010

* cited by examiner

Primary Examiner — David Muller

(74) *Attorney, Agent, or Firm* — Antonelli, Terry, Stout & Kraus, LLP.

(57) **CLAIM**

We claim, the ornamental design for a cartridge casing for a sample collector, as shown and described.

DESCRIPTION

FIG. 1 is a top-right perspective view of a cartridge casing for a sample collector,
 FIG. 2 is a bottom-right perspective view thereof,
 FIG. 3 is a front elevational view thereof,
 FIG. 4 is a rear elevational view thereof,
 FIG. 5 is a top plan view thereof,
 FIG. 6 is a bottom plan view thereof,
 FIG. 7 is a right side elevational view thereof,
 FIG. 8 is a left side elevational view thereof; and,
 FIG. 9 is a sectional view along IX-IX of FIG. 3.
 The cartridge casing is fitted to a detector for use when a sample collector collects samples such as microorganism (e.g. microbes, or fungi), chemical substance, or fine particle, which are floating in the air, and the detector detects the sample.

1 Claim, 5 Drawing Sheets

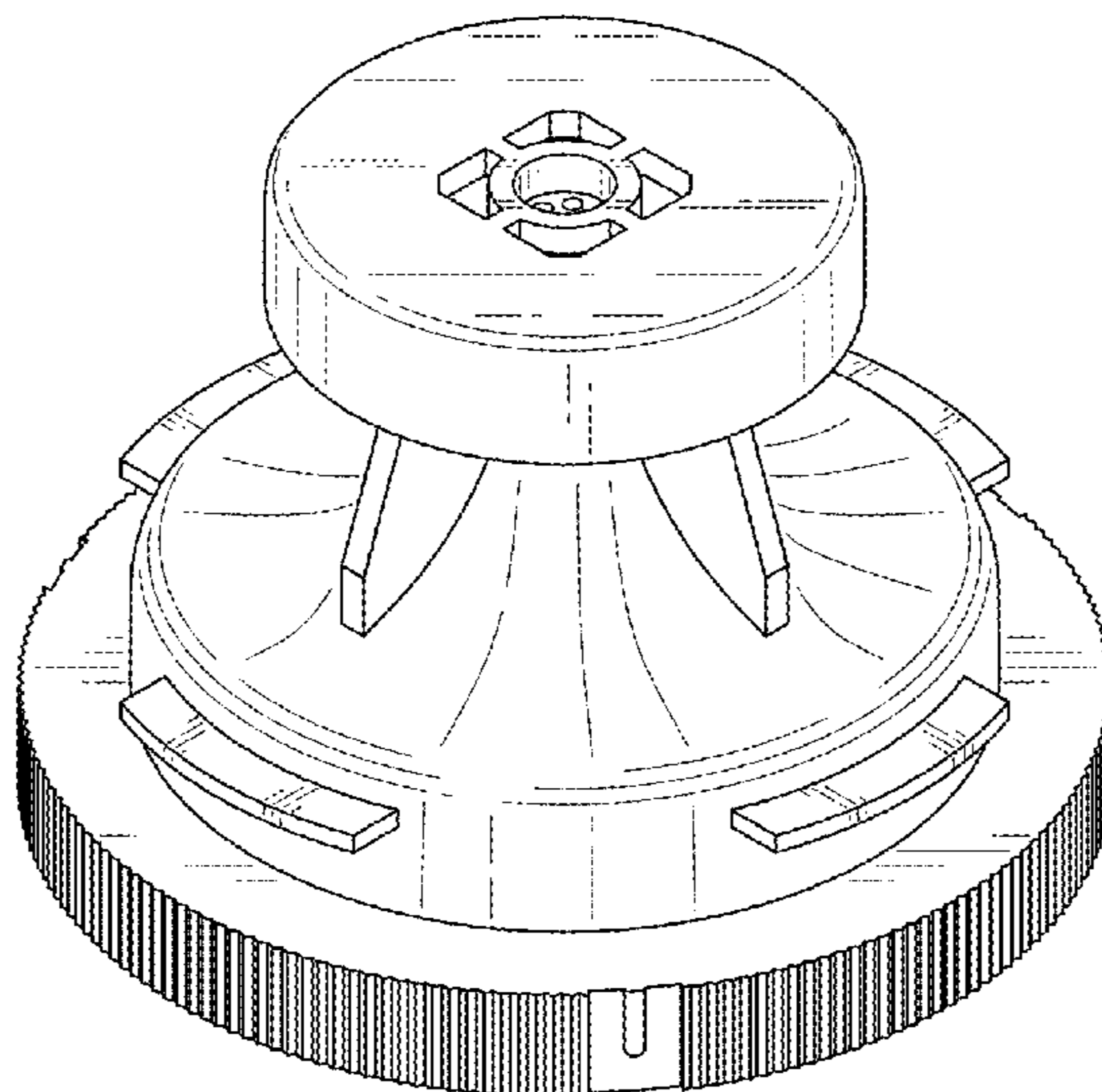

Fig. 1

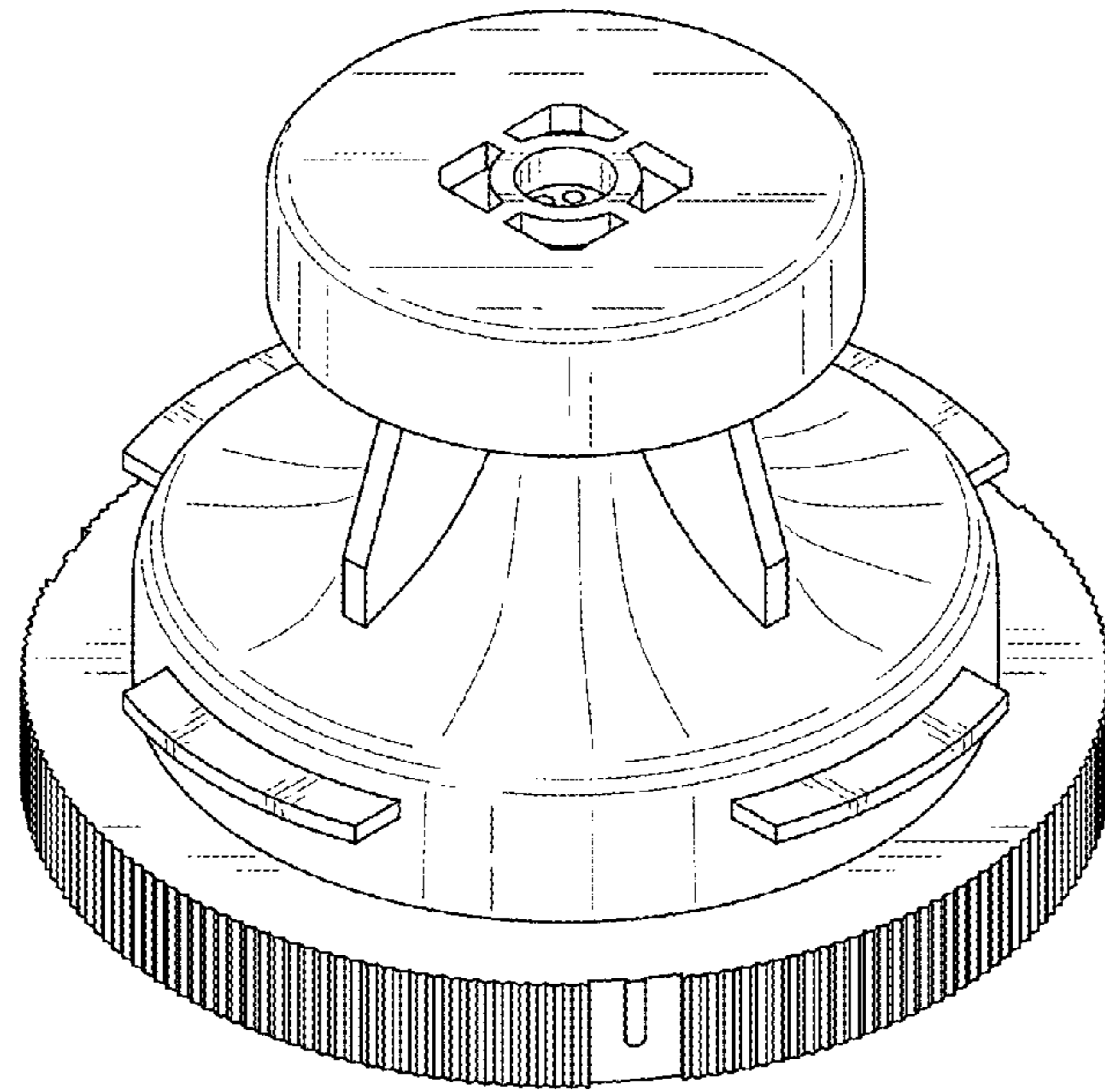

Fig. 2

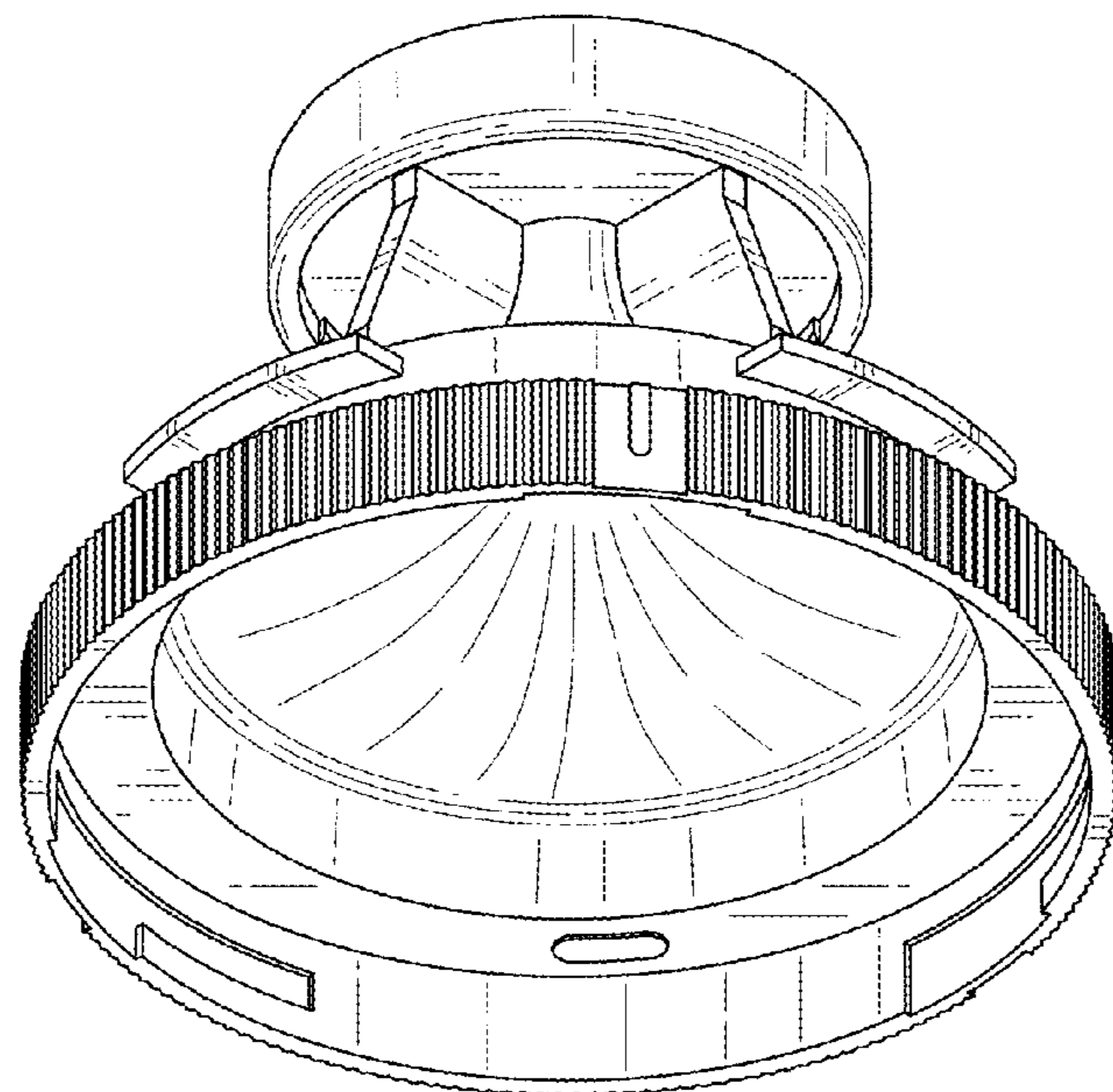

Fig.3

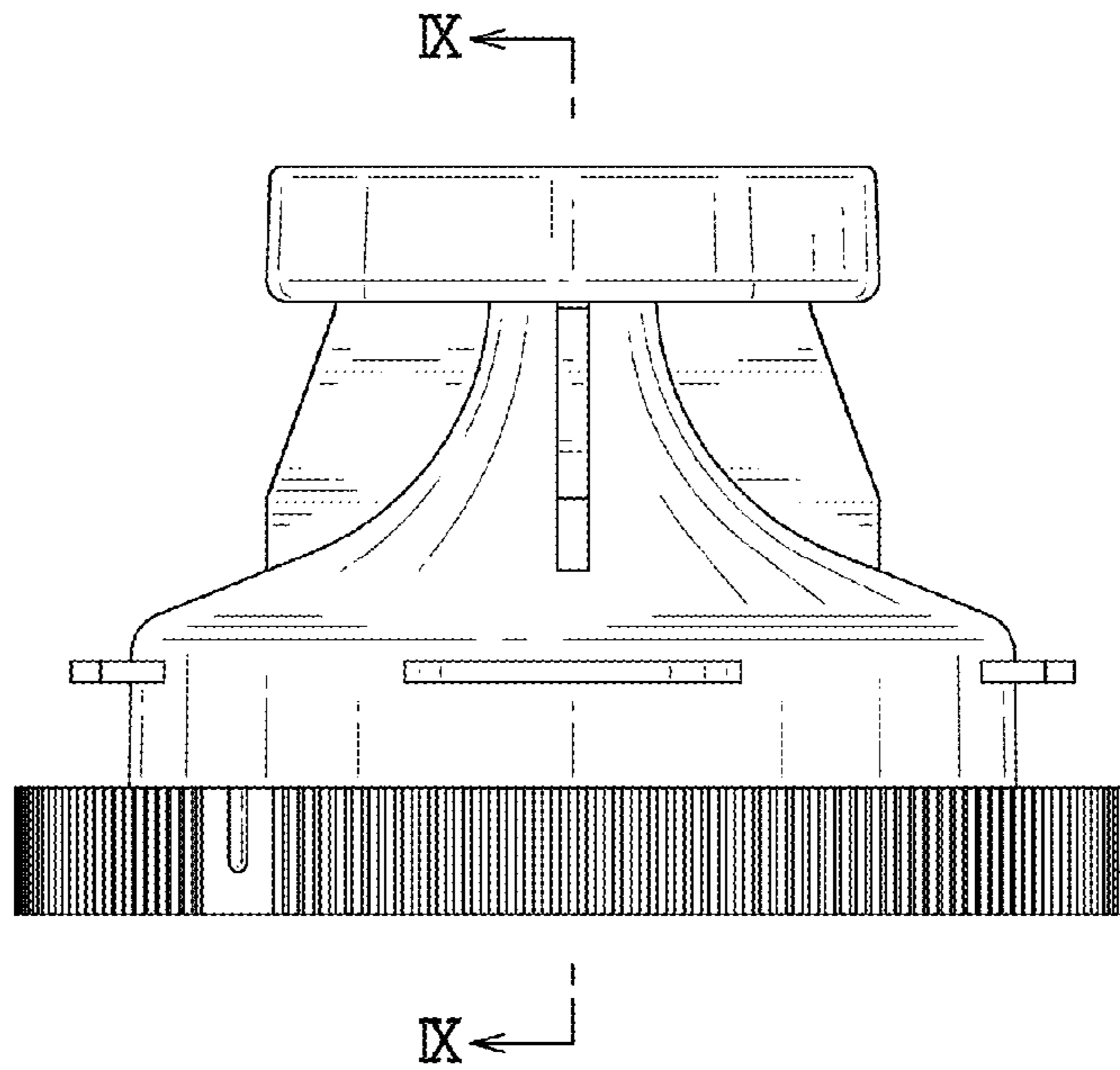

Fig.4

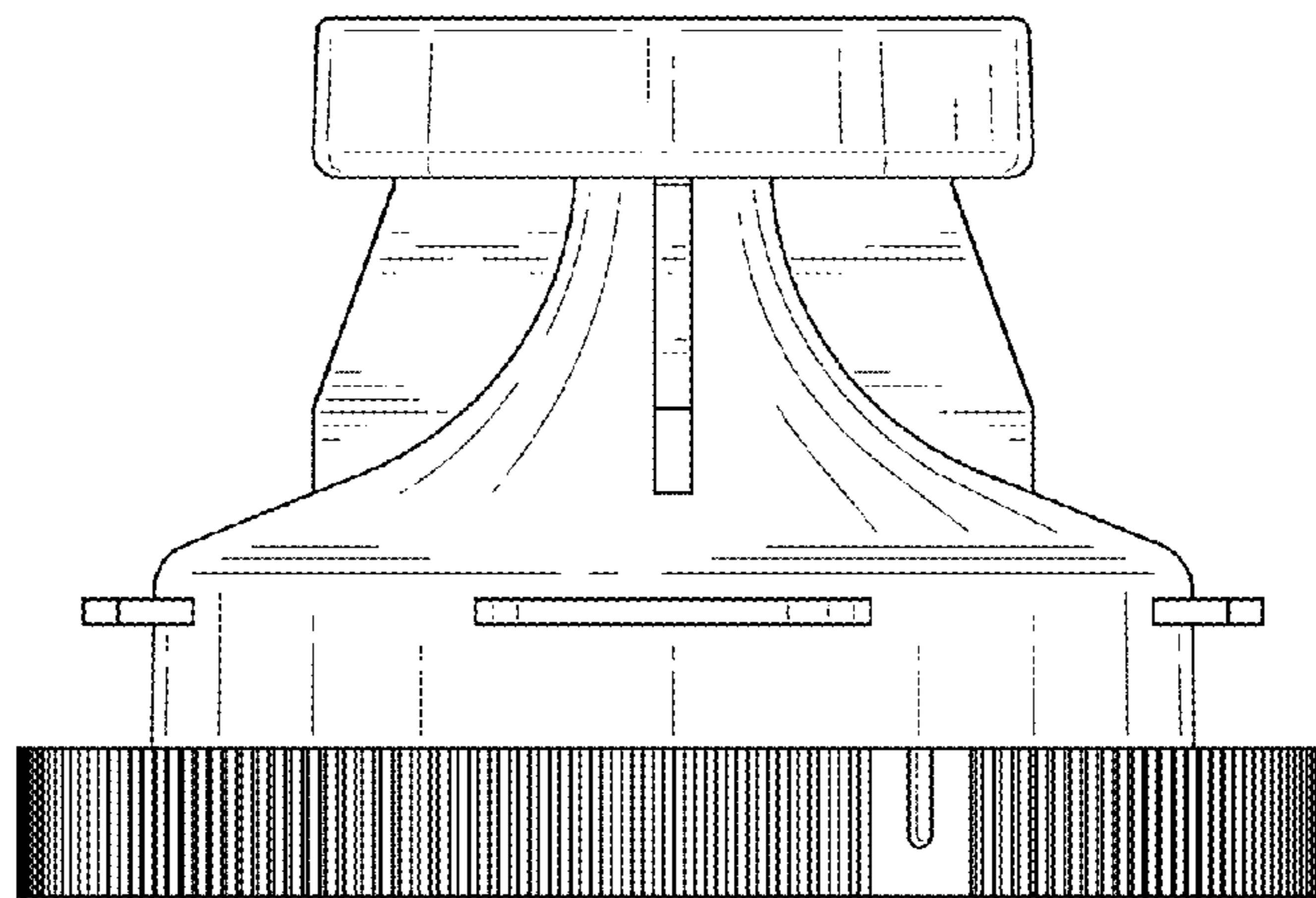

Fig.5

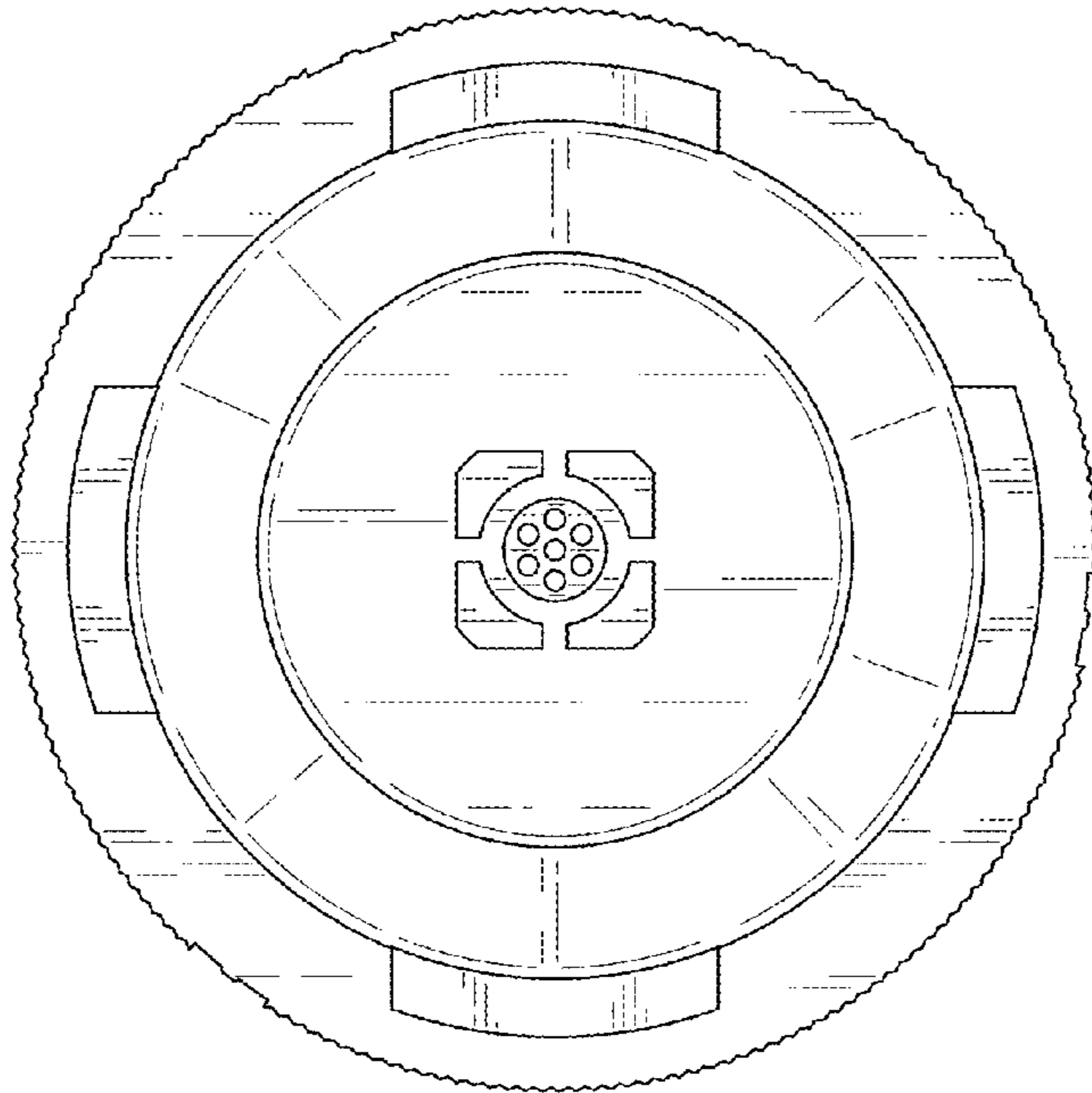

Fig.6

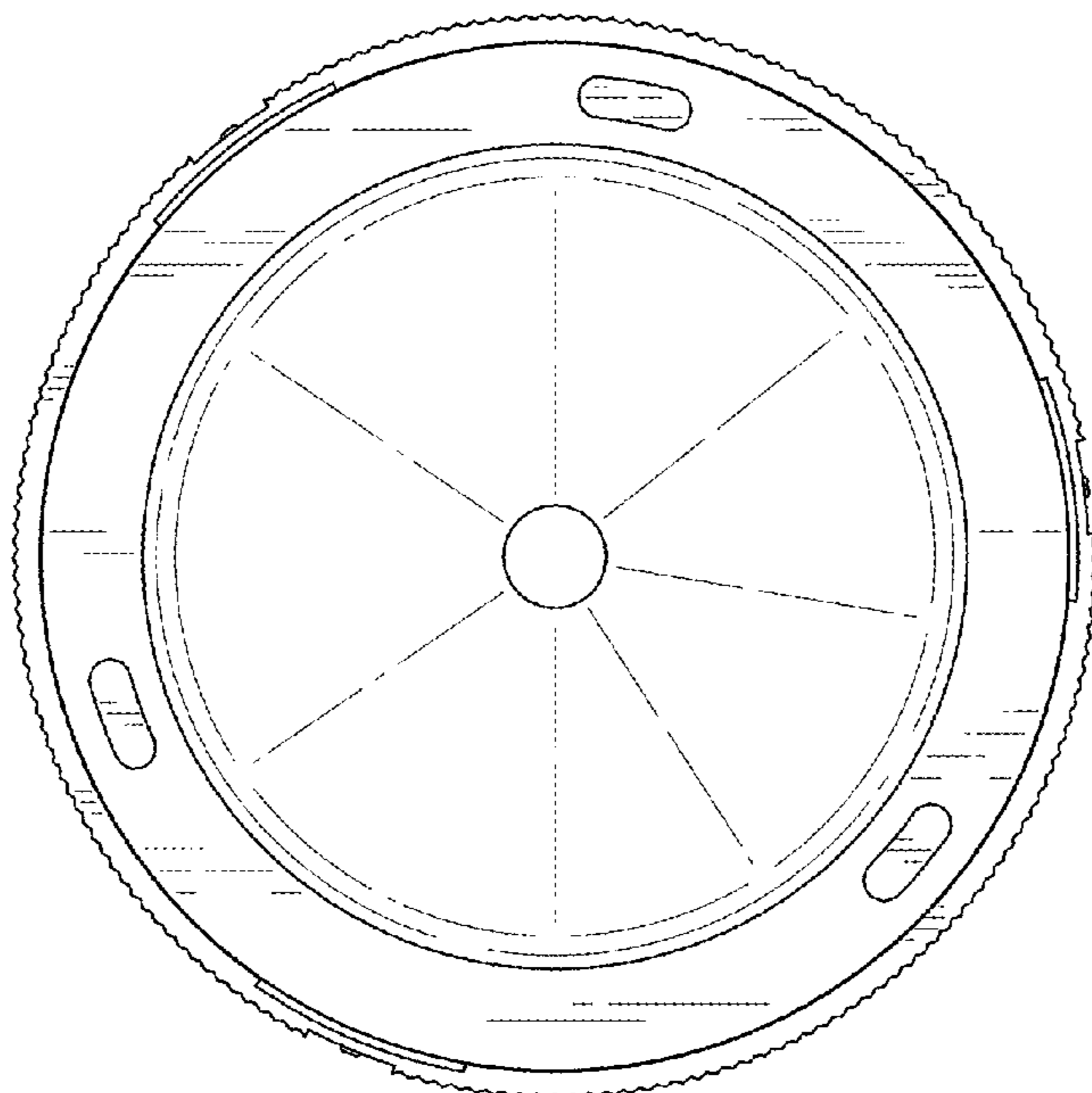

Fig.7

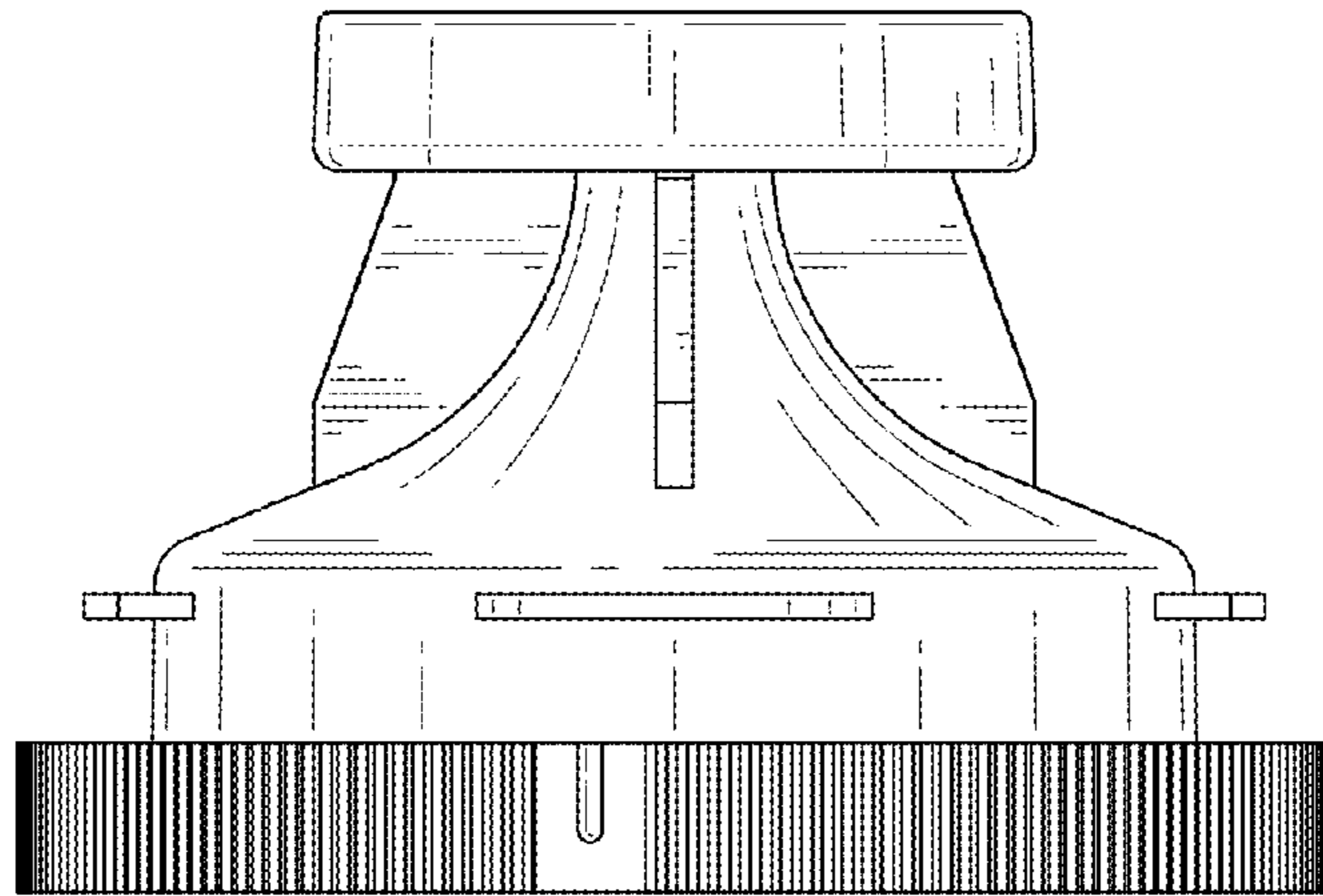

Fig.8

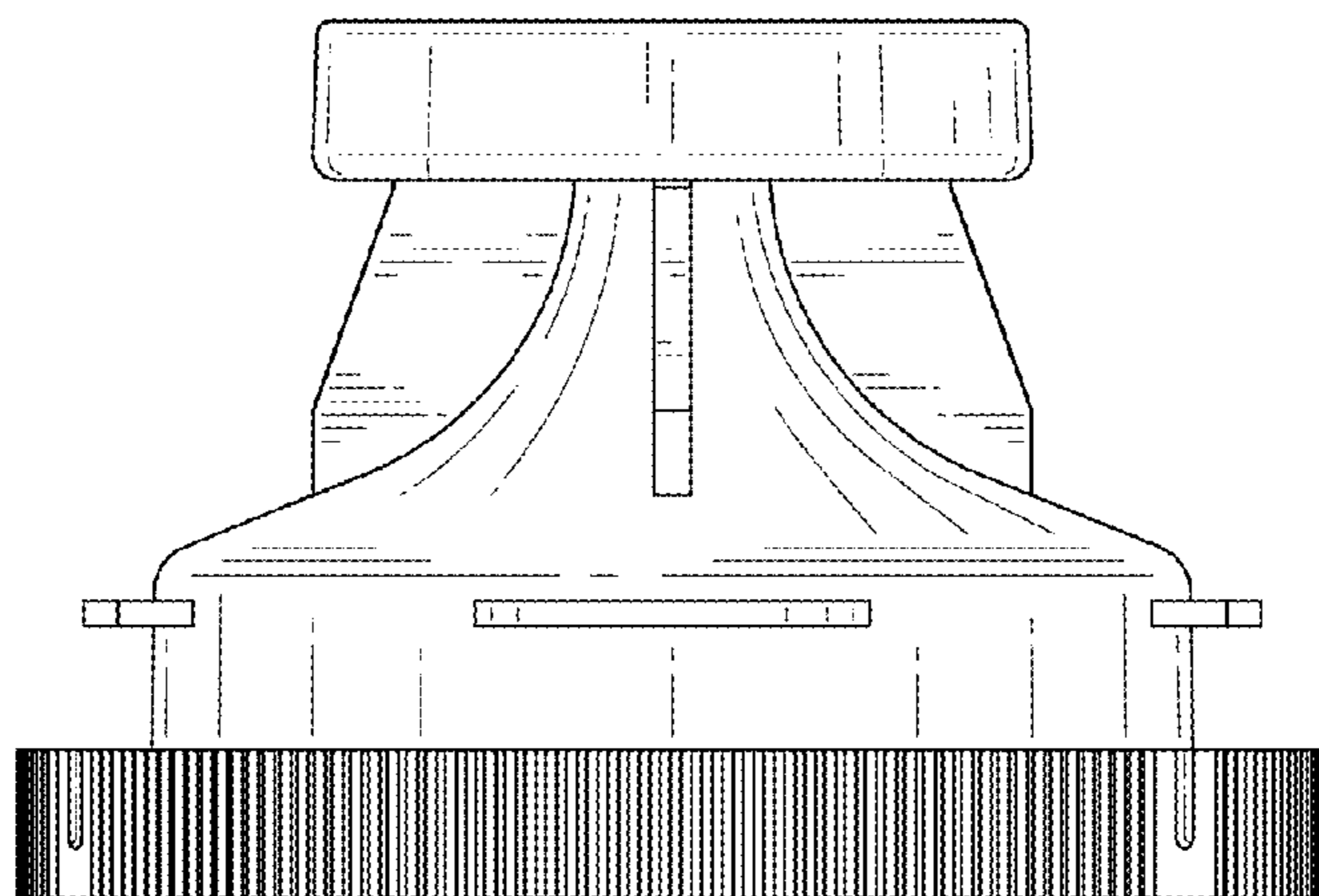

Fig.9

