

US00D695205S

(12) **United States Design Patent**
Guzman et al.

(10) **Patent No.:** **US D695,205 S**

(45) **Date of Patent:** **** Dec. 10, 2013**

(54) **HELICOPTER**

(56) **References Cited**

(76) Inventors: **Edwin Guzman**, Bell Gardens, CA
(US); **Vania Guerrero**, La Habra, CA
(US); **William Zepeda**, Bellflower, CA
(US); **Mario Sanchez**, South Gate, CA
(US); **Jonathan Chavez**, Orange, CA
(US); **Peter Manekas**, Garden Grove,
CA (US); **Nils Nohturfft**, Bruck An De
Mur (AU); **Sonja Zierhut**, Santa Ana,
CA (US)

U.S. PATENT DOCUMENTS

D140,480	S	*	2/1945	Maycen	D12/329
D197,039	S	*	12/1963	Harned et al.	D12/345
3,335,977	A	*	8/1967	Meditz	244/12.4
3,426,982	A	*	2/1969	Markwood	244/7 C
D271,683	S	*	12/1983	Clifton	D12/326
D357,894	S	*	5/1995	Arnold et al.	D12/327
6,089,501	A	*	7/2000	Frost	244/8
6,431,498	B1		8/2002	Watts et al.	
D500,008	S	*	12/2004	Bulaga	D12/345
D524,718	S	*	7/2006	Scott et al.	D12/327
D592,582	S	*	5/2009	Tamm et al.	D12/319

* cited by examiner

Primary Examiner — Caron D Veynar
Assistant Examiner — Martie K Holtje
(74) *Attorney, Agent, or Firm* — Christie, Parker & Hale,
LLP

(**) **Term:** **14 Years**

(21) **Appl. No.:** **29/429,804**

(22) **Filed:** **Aug. 16, 2012**

(51) **LOC (9) Cl.** **12-07**

(52) **U.S. Cl.**
USPC **D12/326**; D21/442; D12/328

(58) **Field of Classification Search**
USPC D12/319, 326, 327, 328, 329, 330,
D12/331–334, 337, 338, 339, 343, 344, 345,
D12/16.1; D21/430, 441, 442, 446, 447,
D21/448, 449, 450, 451, 452, 453; 244/2, 5,
244/6, 7 C, 7 R, 8, 12.1, 12.3, 12.4, 17.11,
244/17.19, 17.23, 17.25, 17.27, 99.1, 118.5,
244/60, 63; 280/1.12; 446/36, 56, 57, 58,
446/211, 230, 231, 232, 233, 235

See application file for complete search history.

(57) **CLAIM**
The ornamental design for a helicopter, as shown and
described.

DESCRIPTION

FIG. 1 is a right front perspective view of a helicopter show-
ing our new design;
FIG. 2 is a top plan view thereof;
FIG. 3 is a right side elevational view thereof;
FIG. 4 is a front elevation view thereof;
FIG. 5 is a left side elevational view thereof;
FIG. 6 is a rear elevational view thereof; and,
FIG. 7 is a bottom plan view thereof.
The broken line showing of structural elements is included for
the purpose of illustrating portions of the helicopter which
form no part of the claimed design.

1 Claim, 6 Drawing Sheets

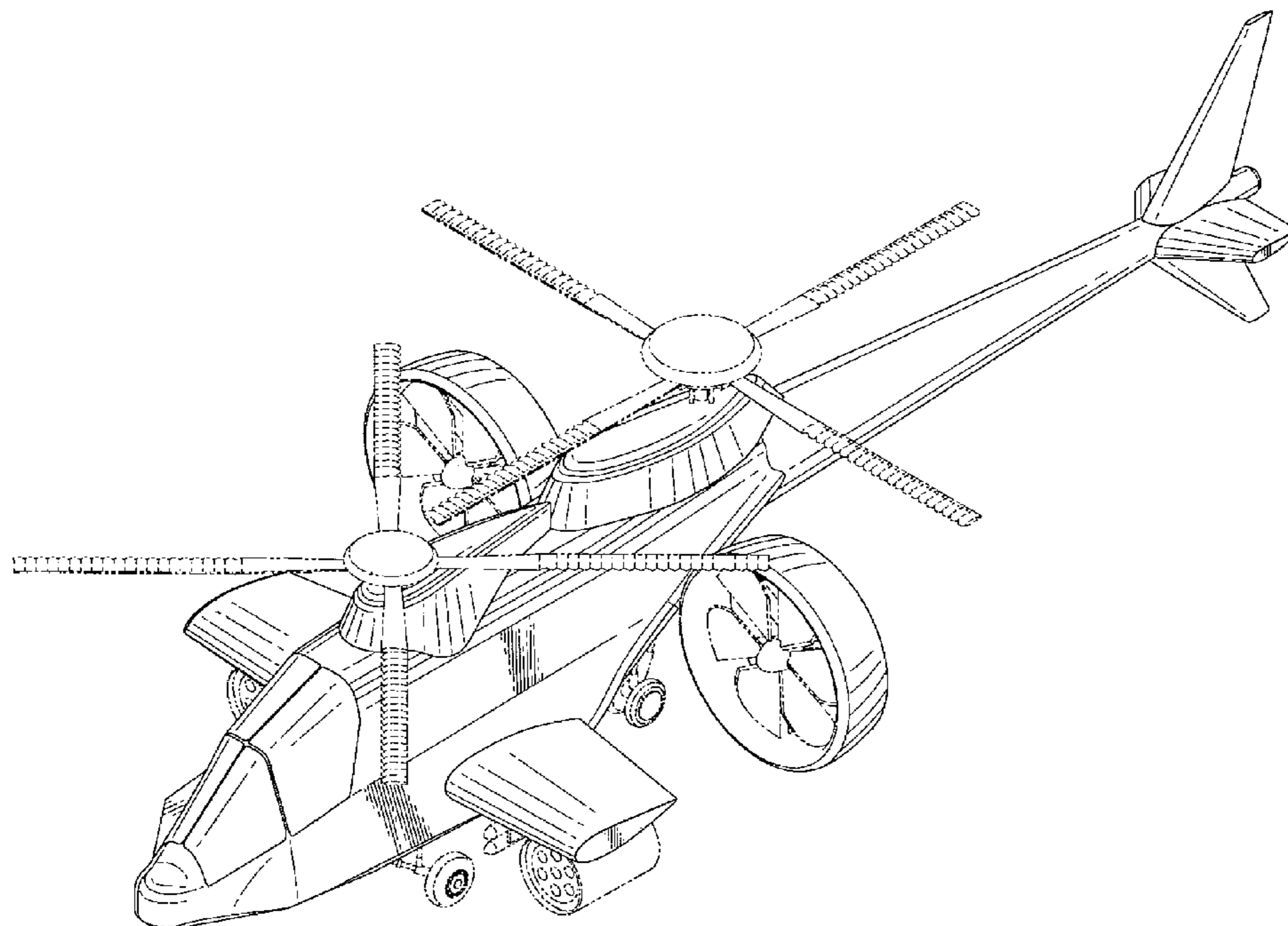

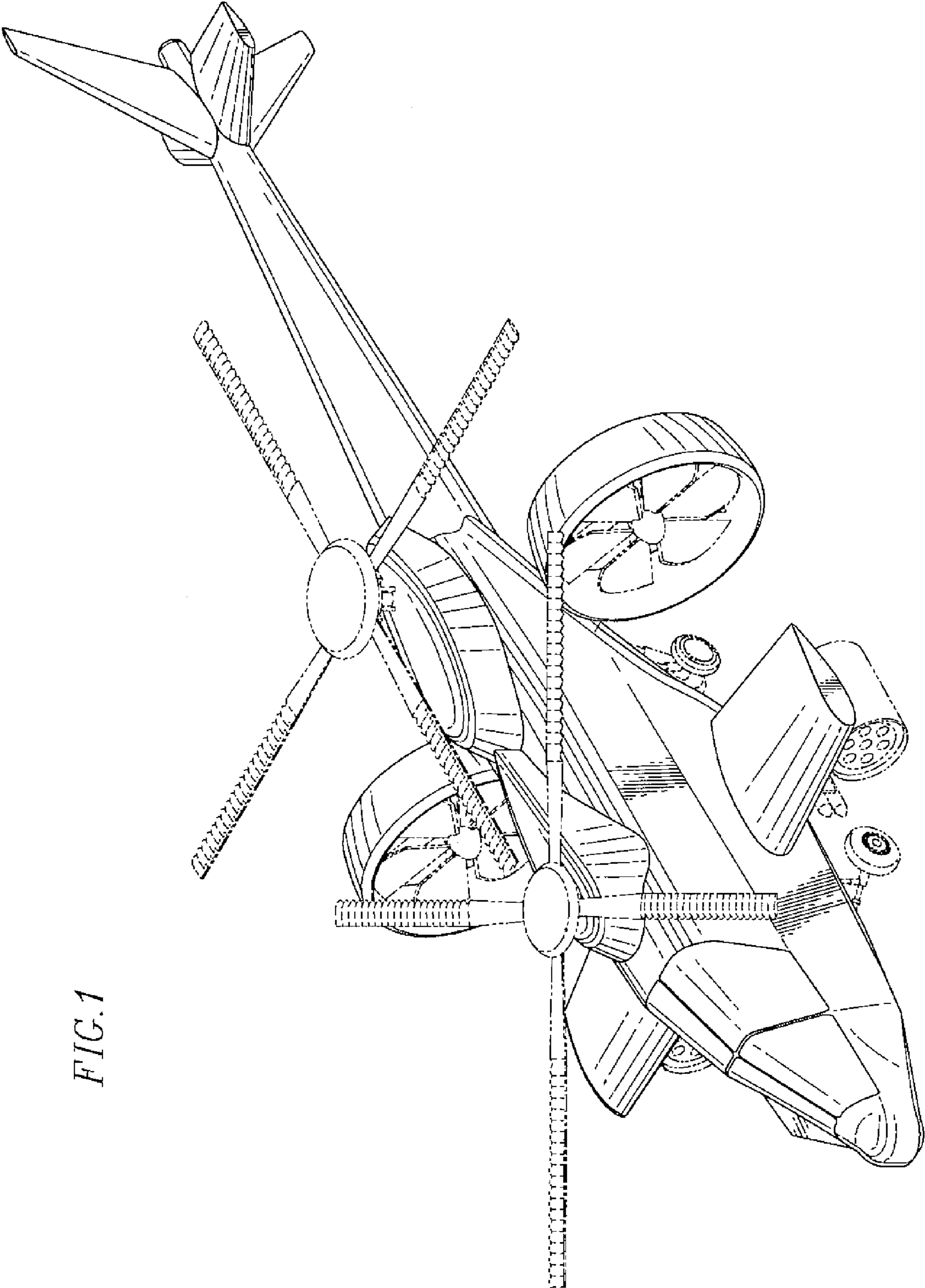

FIG. 1

FIG. 2

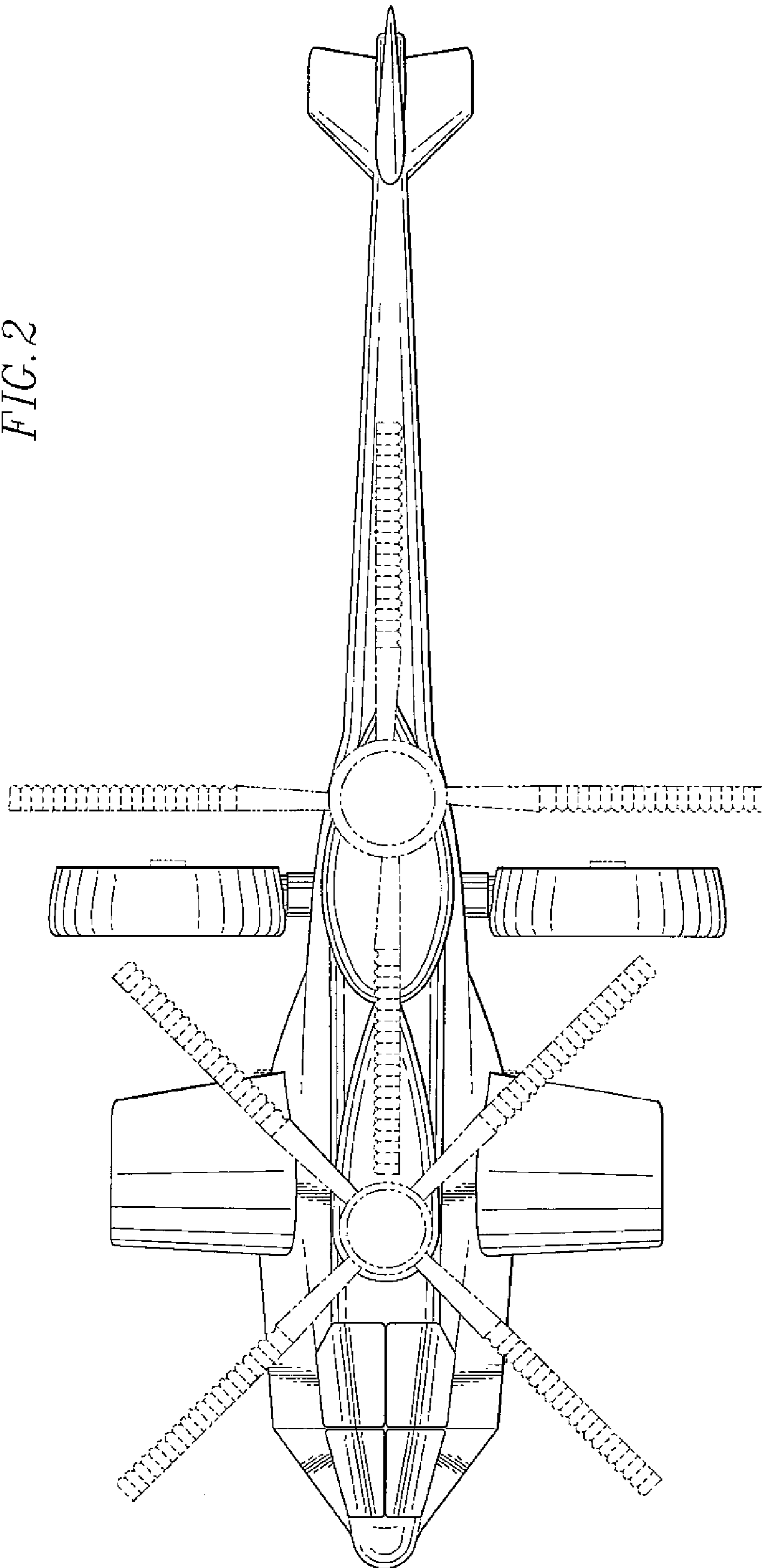

FIG. 3

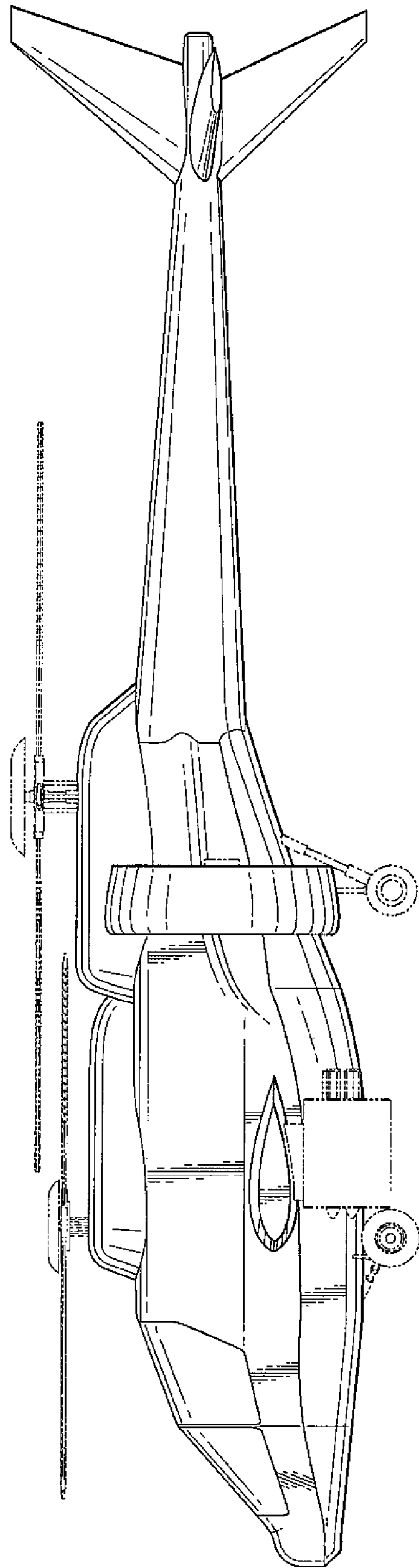

FIG. 6

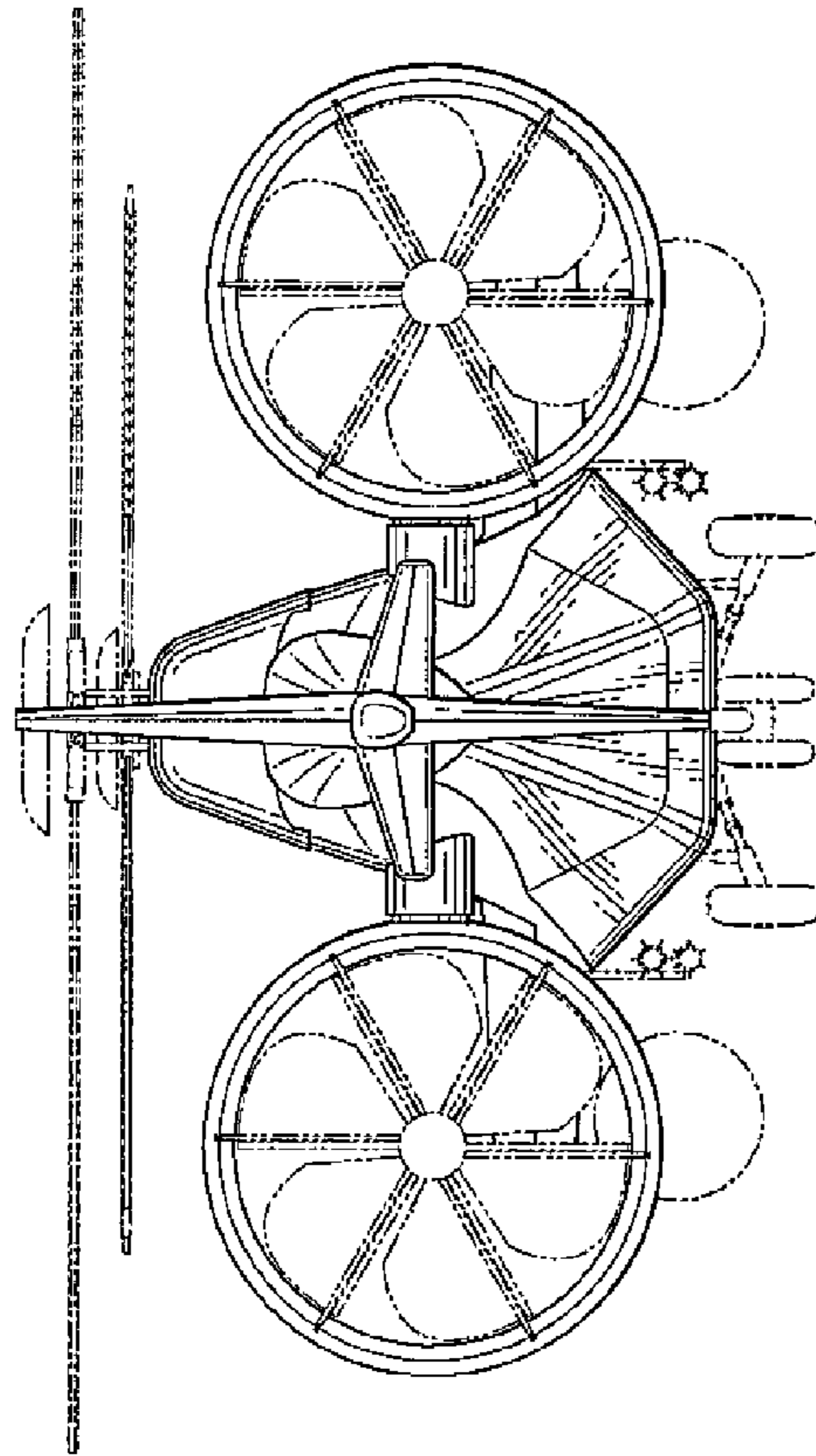

FIG. 4

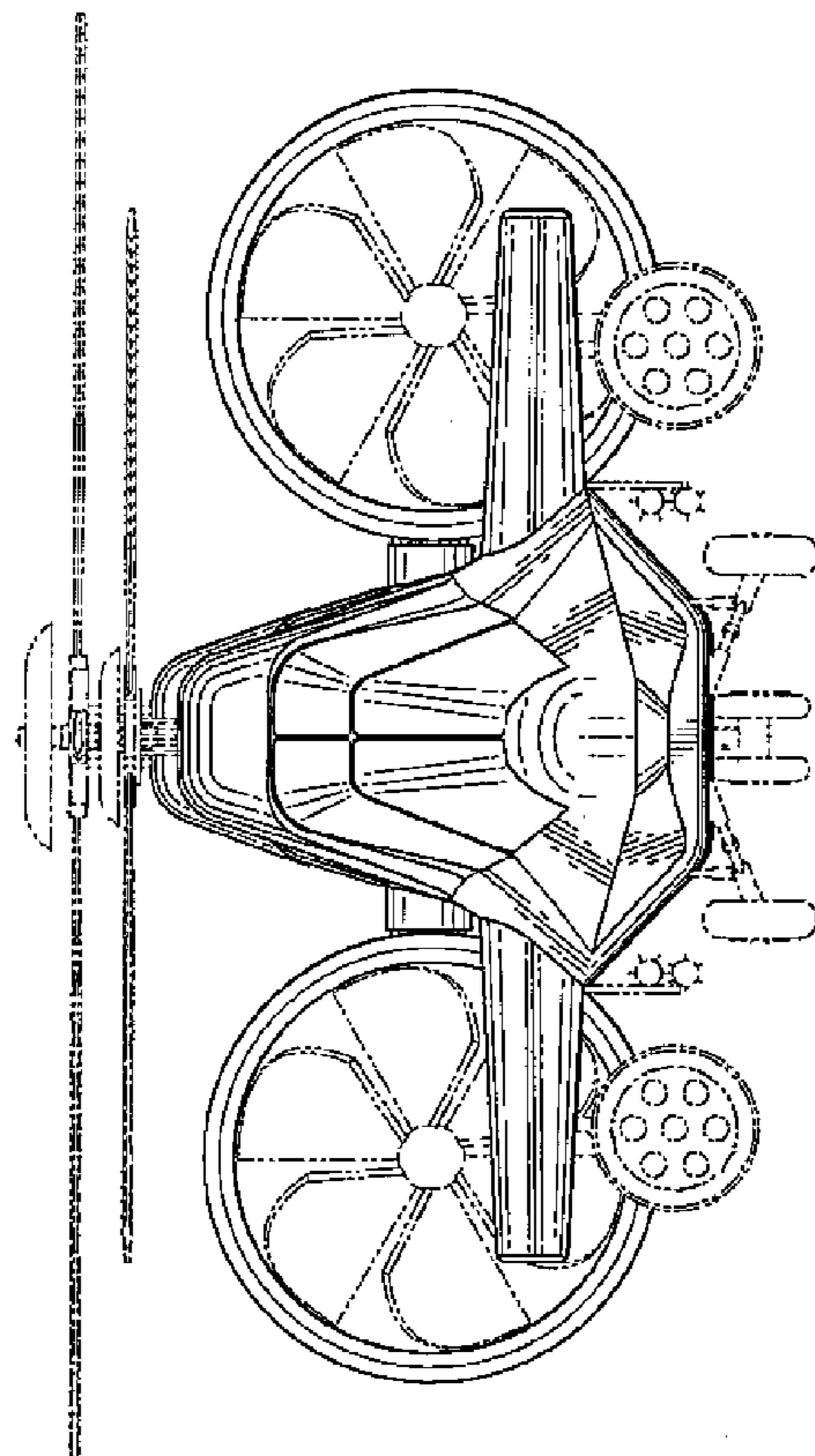

FIG. 5

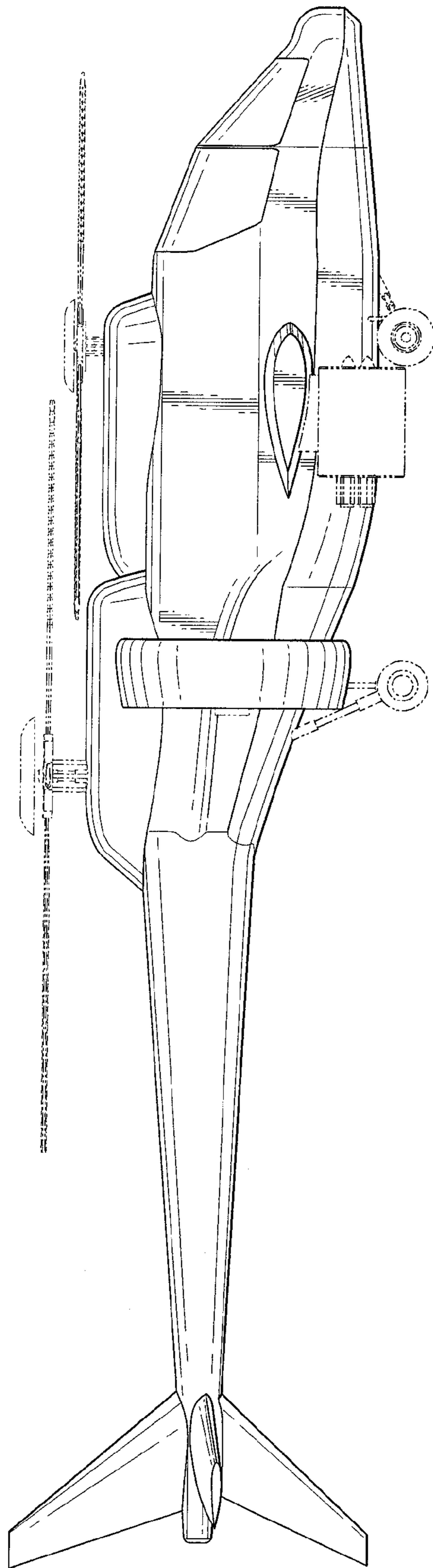

FIG. 7

