



US00D694920S

(12) **United States Design Patent**
Jurgens et al.

(10) **Patent No.:** **US D694,920 S**

(45) **Date of Patent:** **** Dec. 3, 2013**

(54) **VEHICLE LIGHT**

(71) Applicants: **Owen Thurston Jurgens**, Swan Hill (AU); **Philippa Jane Jurgens**, Swan Hill (AU); **Terence Jurgens**, Swan Hill (AU); **Elise Rachael Jurgens**, Swan Hill (AU)

(72) Inventors: **Terence Jurgens**, Swan Hill (AU); **Rosalind Jane Jurgens**, Swan Hill (AU)

(73) Assignees: **Owen Thurston Jurgens**, Swan Hill, Victoria (AU); **Philippa Jane Jurgens**, Swan Hill, Victoria (AU); **Terence Jurgens**, Swan Hill, Victoria (AU); **Elise Rachael Jurgens**, Swan Hill, Victoria (AU)

(**) Term: **14 Years**

(21) Appl. No.: **29/447,631**

(22) Filed: **Mar. 5, 2013**

(30) **Foreign Application Priority Data**

Sep. 5, 2012 (AU) 14359/2012

(51) **LOC (9) Cl.** **26-06**

(52) **U.S. Cl.**
USPC **D26/28**

(58) **Field of Classification Search**
USPC D26/28-36; 362/459-468, 475-478, 362/485-487
See application file for complete search history.

(56) **References Cited**

U.S. PATENT DOCUMENTS

D601,727 S	*	10/2009	Huang	D26/28
D605,789 S	*	12/2009	Ko	D26/28
D626,670 S	*	11/2010	Metzger et al.	D26/28
D657,081 S	*	4/2012	Alisauskas et al.	D26/28
D670,839 S	*	11/2012	Smarslik	D26/28

* cited by examiner

Primary Examiner — Marcus Jackson

(74) *Attorney, Agent, or Firm* — Andrus, Scales, Starke & Sawall, LLP

(57) **CLAIM**

The ornamental design of a vehicle light, as shown.

DESCRIPTION

FIG. 1 is a perspective view showing an embodiment of our design;
FIG. 2 is a front view thereof;
FIG. 3 is a rear view thereof;
FIG. 4 is a top view thereof;
FIG. 5 is a bottom view thereof; and,
FIG. 6 is a left side view thereof.

1 Claim, 4 Drawing Sheets

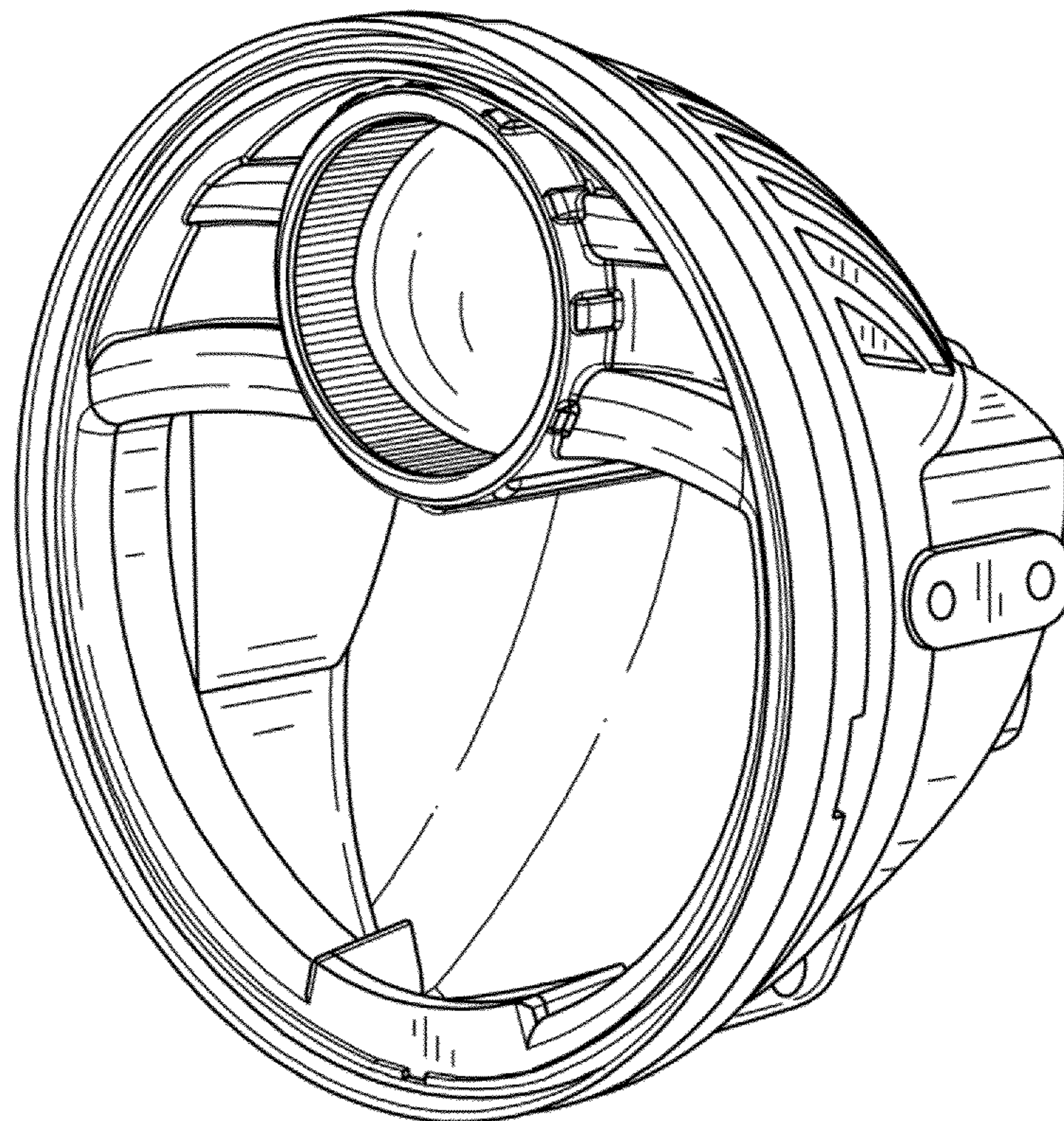

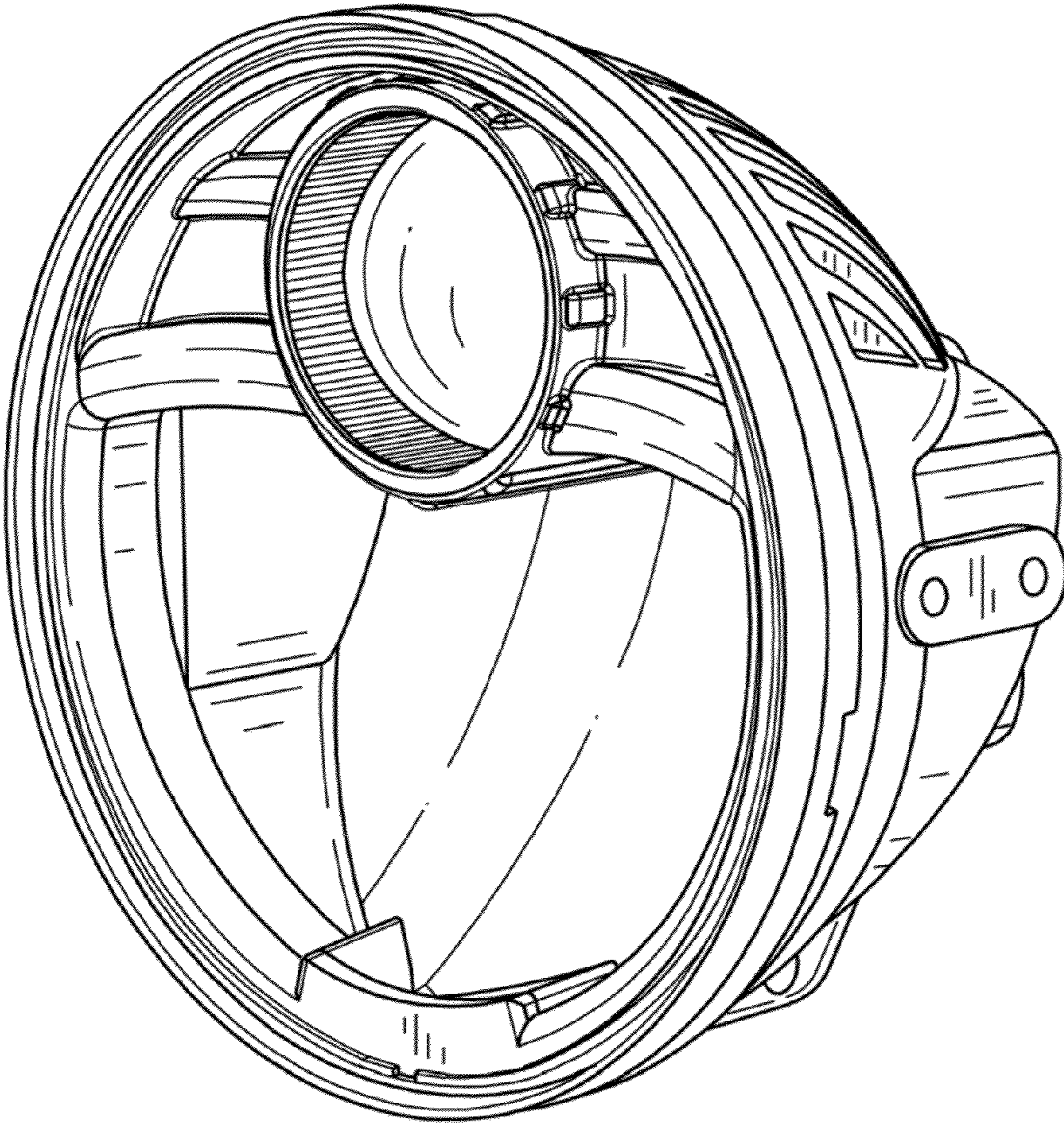

FIG. 1

FIG. 2

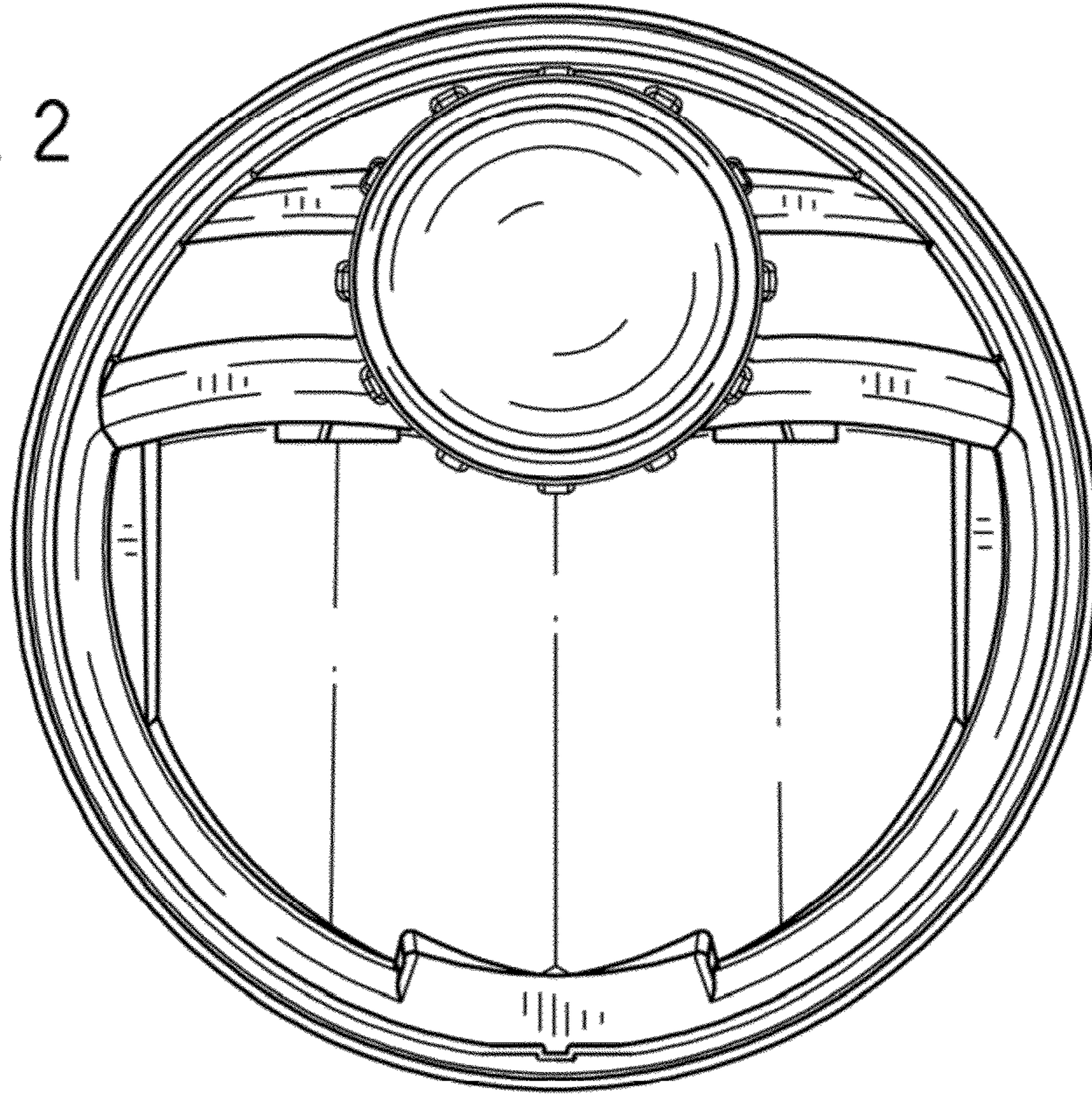
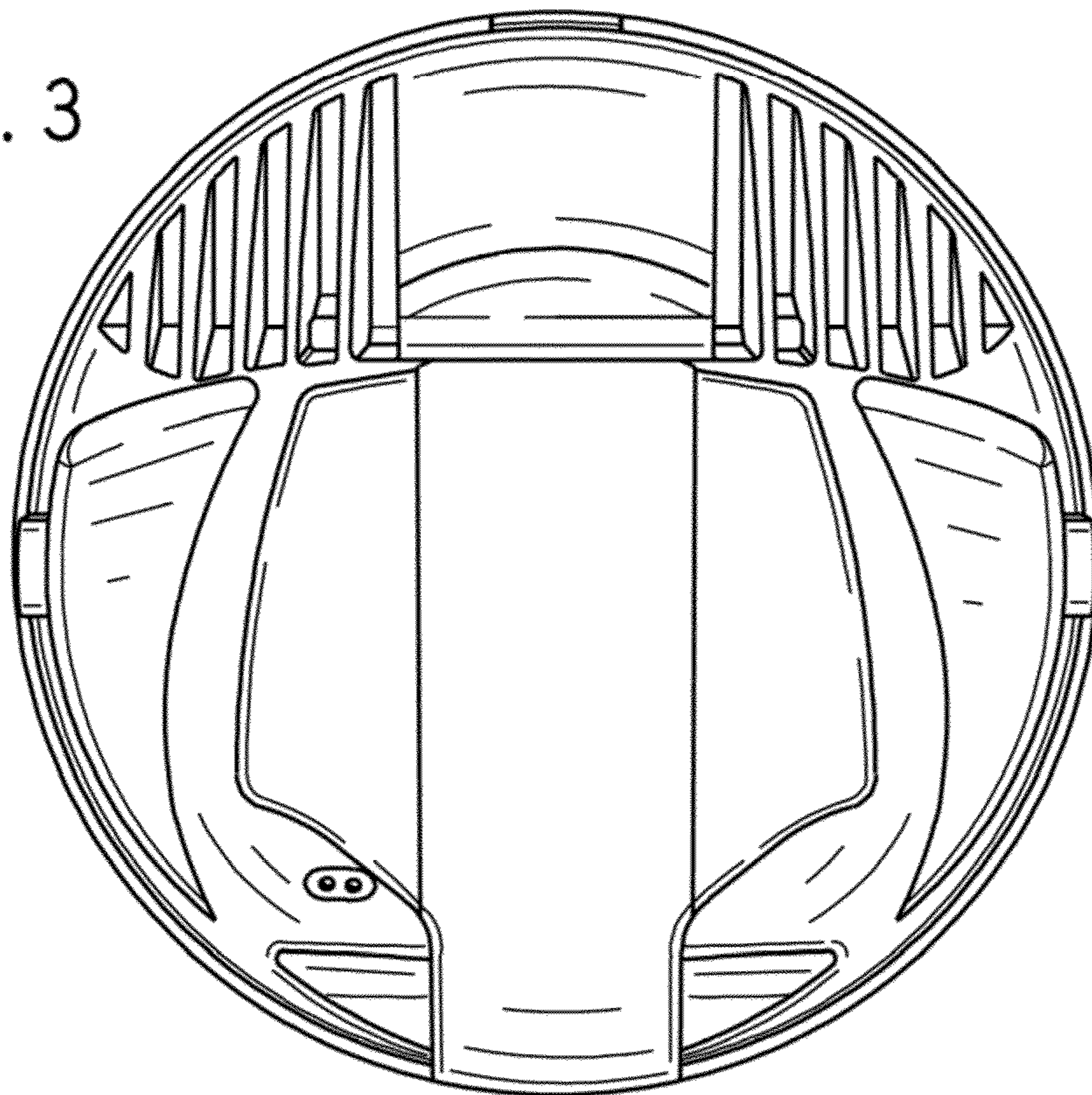

FIG. 3



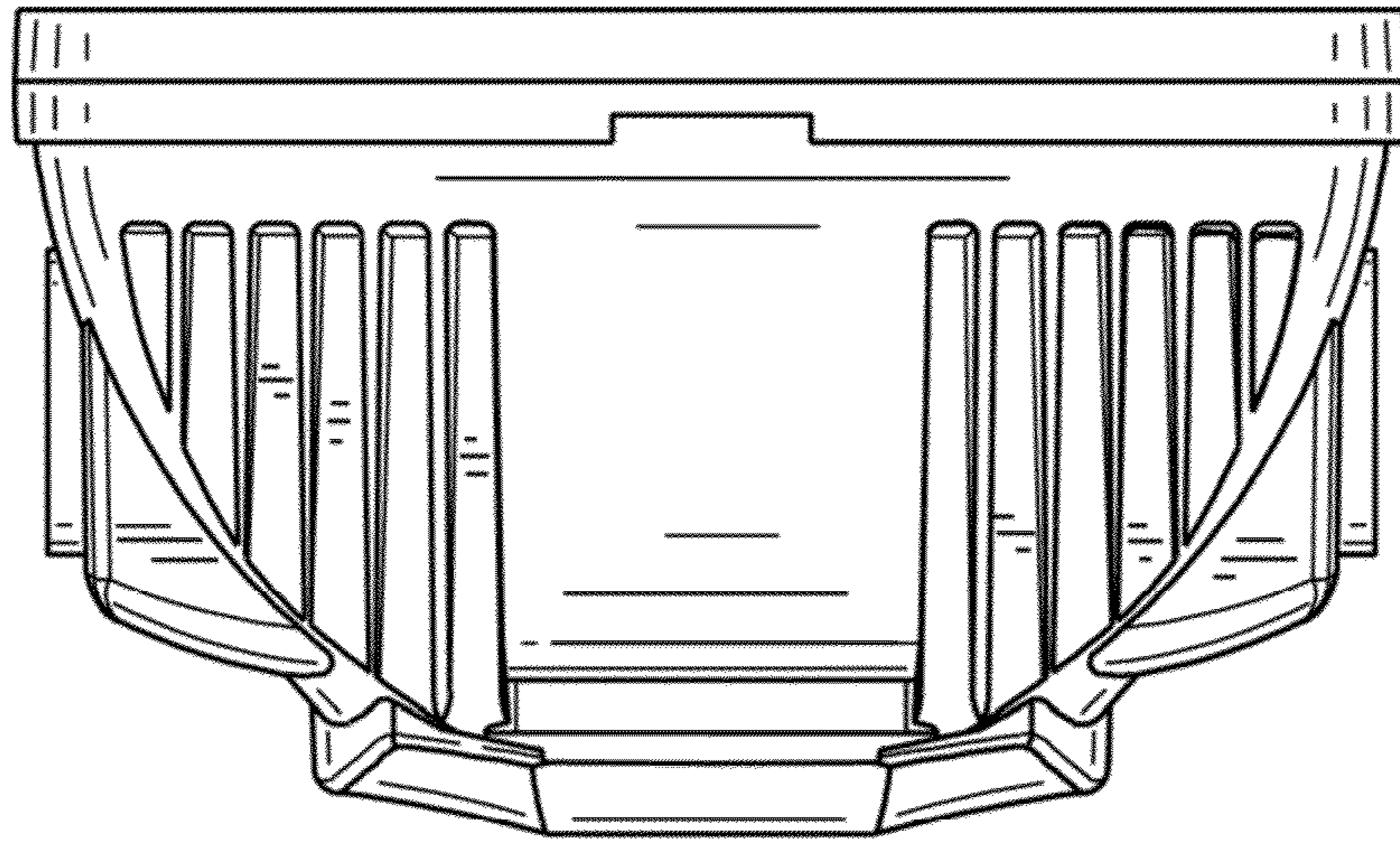

FIG. 4

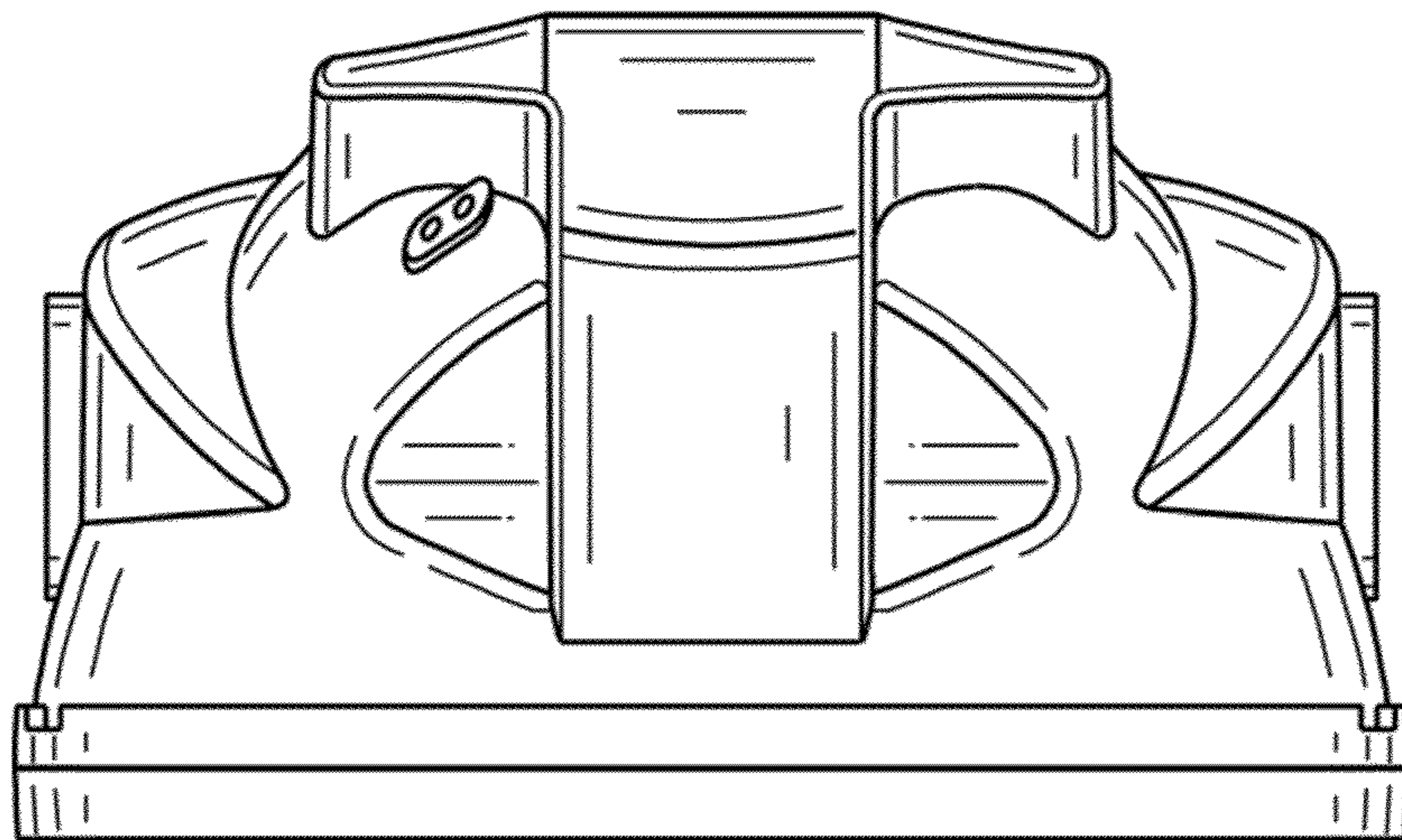

FIG. 5

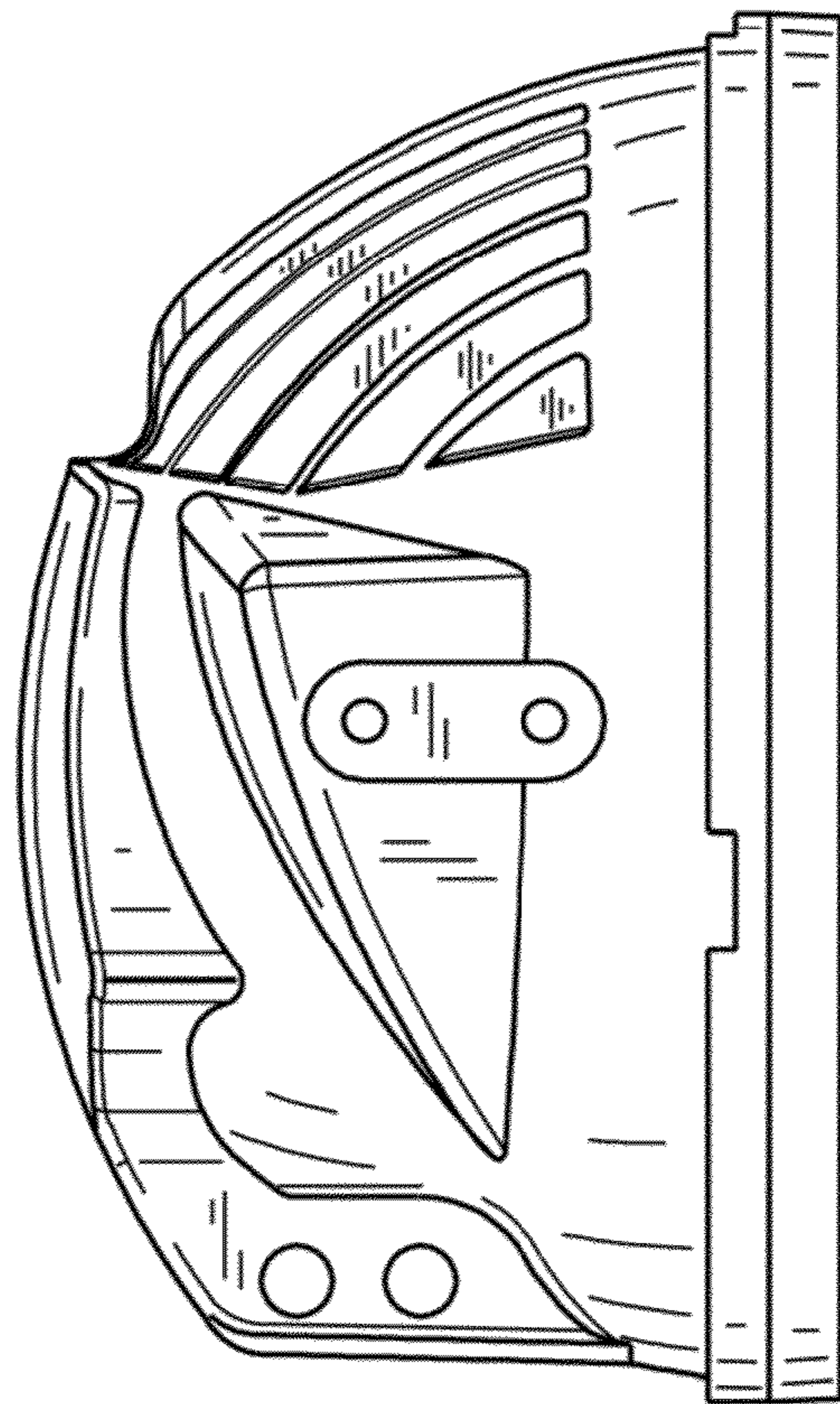

FIG. 6