



US00D694890S

(12) **United States Design Patent**
Bott et al.

(10) **Patent No.:** **US D694,890 S**
(45) **Date of Patent:** **** Dec. 3, 2013**

(54) **LASER SYSTEM FOR TREATMENT OF THE EYE**

(75) Inventors: **Steven E. Bott**, Oviedo, FL (US);
Rudolph W. Frey, Winter Park, FL (US); **Gerrit N. Porter**, Winter Springs, FL (US); **Scott Howard Wakefield**, Andover, MA (US); **William D. Chura**, Newton, MA (US)

(73) Assignee: **LensAR, Inc.**, Orlando, FL (US)

(**) Term: **14 Years**

(21) Appl. No.: **29/377,054**

(22) Filed: **Oct. 15, 2010**

(51) **LOC (9) Cl.** **24-01**

(52) **U.S. Cl.**
USPC **D24/172**

(58) **Field of Classification Search**

USPC D24/107, 108, 137, 138, 144, 150, 160, D24/172, 177, 185, 186, 231, 232; 128/898; 312/209, 223.1, 223.2, 223.6, 249.8, 312/249.11, 249.12, 250; 604/4, 5, 6, 11, 604/22, 27, 65, 66, 67; 606/4, 5, 6, 10, 16, 606/17, 18, 34

See application file for complete search history.

(56) **References Cited**

U.S. PATENT DOCUMENTS

3,074,407 A 1/1963 Moon et al.
3,971,382 A 7/1976 Krasnov
3,982,541 A 9/1976 L'Esperance, Jr.
4,024,852 A 5/1977 L'Esperance et al.
D245,917 S * 9/1977 Armbruster D24/172
4,263,893 A 4/1981 Pavlak et al.

(Continued)

FOREIGN PATENT DOCUMENTS

CA 2553963 A1 8/2005
CA 2680072 A1 9/2008

(Continued)

OTHER PUBLICATIONS

U.S. Appl. No. 11/337,127, filed Jan. 20, 2006, Frey et al.

(Continued)

Primary Examiner — Patricia Palasik

(74) *Attorney, Agent, or Firm* — Brinks Hofer Gilson & Lione

(57) **CLAIM**

We claim the ornamental design for a laser system for treatment of the eye, as shown and described.

DESCRIPTION

FIG. 1 is a right side perspective view showing an embodiment of our new design for a laser system for treatment of the eye;

FIG. 2 is a left side view showing our new design shown in FIG. 1;

FIG. 3 is a right side view showing our new design shown in FIG. 1;

FIG. 4 is a front view showing our new design shown in FIG. 1;

FIG. 5 is a rear view showing our new design shown in FIG. 1;

FIG. 6 is a top view of our design shown in FIG. 1;

FIG. 7 is a bottom view of our design shown in FIG. 1;

FIG. 8 is a top, right perspective view of our design shown in FIG. 1; and,

FIG. 9 is a second top, right perspective view of our design shown in FIG. 1.

The broken lines in FIGS. 1-9 are for environmental purposes only and form no part of the claimed design.

1 Claim, 9 Drawing Sheets

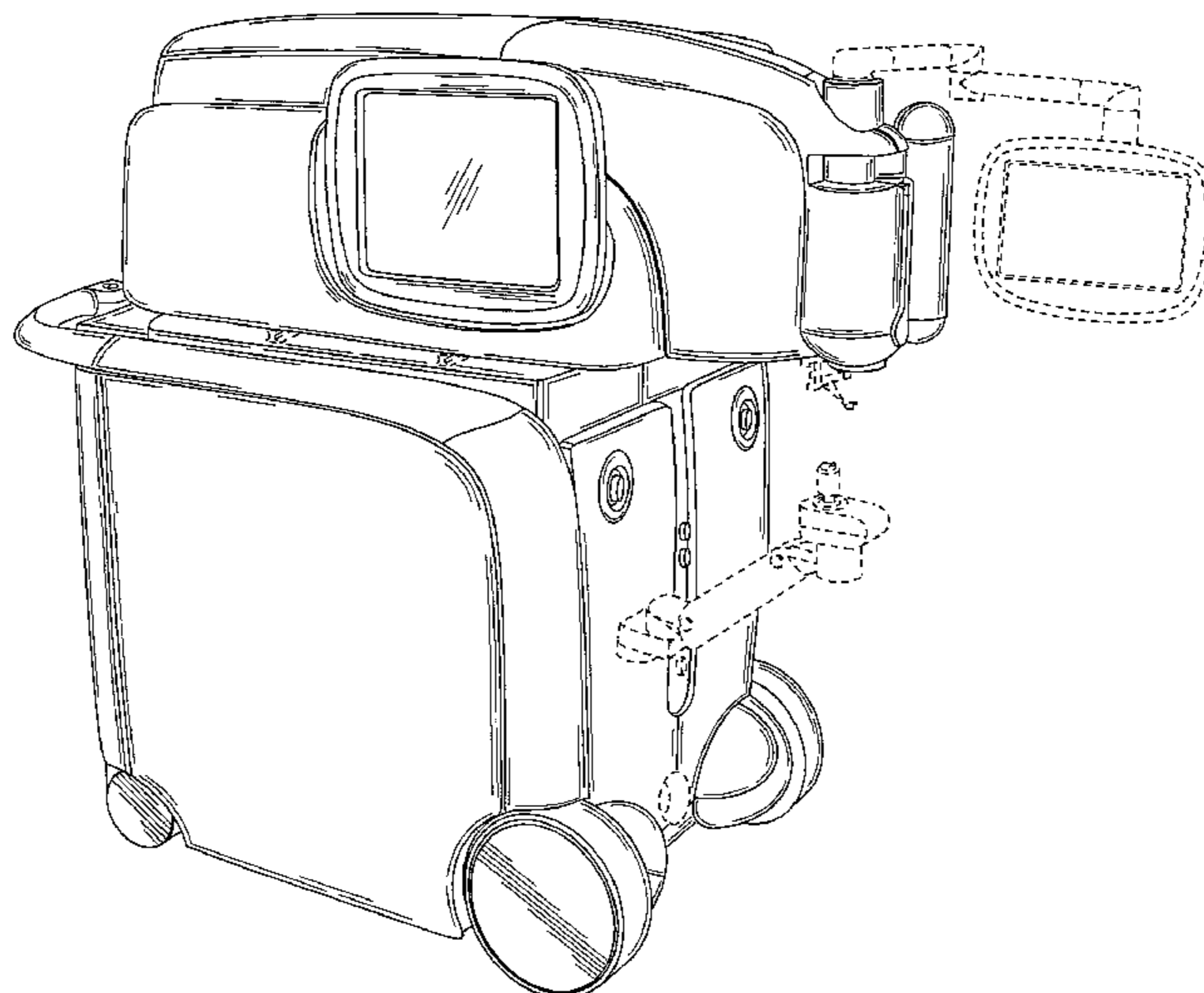

(56)

References Cited

U.S. PATENT DOCUMENTS

4,309,998 A	1/1982	Aron nee Rosa et al.	4,865,441 A	9/1989	Reis
4,334,736 A	6/1982	Herbert	4,866,243 A	9/1989	Sakane et al.
4,381,007 A	4/1983	Doss	4,870,952 A	10/1989	Martinez
4,394,144 A	7/1983	Aoki	4,881,808 A	11/1989	Bille et al.
4,461,294 A	7/1984	Baron	4,883,351 A	11/1989	Weiss
4,477,159 A	10/1984	Mizuno et al.	4,884,884 A	12/1989	Reis
4,502,816 A	3/1985	Creter, Jr. et al.	4,887,019 A	12/1989	Reis et al.
4,517,980 A	5/1985	Tagnon	4,887,592 A	12/1989	Loertscher
4,537,193 A	8/1985	Tanner	4,891,043 A	1/1990	Zeimer et al.
4,538,608 A	9/1985	L'Esperance, Jr.	4,900,143 A	2/1990	Bessler et al.
4,554,917 A	11/1985	Tagnon	4,900,145 A	2/1990	Akiyama
4,561,436 A	12/1985	Munnerlyn	4,901,718 A	2/1990	Bille et al.
4,565,197 A	1/1986	Daly	4,902,124 A	2/1990	Roy, Sr. et al.
4,573,778 A	3/1986	Shapiro	4,903,695 A	2/1990	Warner et al.
4,576,160 A	3/1986	Tanaka	4,905,711 A	3/1990	Bennett et al.
4,579,430 A	4/1986	Bille	4,907,586 A	3/1990	Bille et al.
4,580,559 A	4/1986	L'Esperance	4,911,160 A	3/1990	Thyzel
4,582,405 A	4/1986	Muller et al.	4,911,711 A	3/1990	Telfair et al.
4,583,539 A	4/1986	Karlin et al.	4,917,486 A	4/1990	Raven et al.
4,588,505 A	5/1986	Walley et al.	4,931,053 A	6/1990	L'Esperance, Jr.
4,601,037 A	7/1986	McDonald	4,941,093 A	7/1990	Marshall et al.
4,601,288 A	7/1986	Myers	4,951,663 A	8/1990	L'Esperance, Jr.
4,607,622 A	8/1986	Fritch et al.	4,953,969 A	9/1990	Fedorov
4,628,416 A	12/1986	Dewey	4,966,577 A	10/1990	Crosson et al.
4,633,866 A	1/1987	Peyman et al.	4,972,836 A	11/1990	Schenck et al.
4,638,801 A	1/1987	Daly et al.	4,973,330 A	11/1990	Azema et al.
4,644,948 A	2/1987	Lang et al.	4,976,709 A	12/1990	Sand
4,648,400 A	3/1987	Schneider et al.	4,988,348 A	1/1991	Bille
4,657,013 A	4/1987	Hoerenz et al.	4,994,058 A	2/1991	Raven et al.
4,665,913 A	5/1987	L'Esperance, Jr.	5,000,561 A	3/1991	Lawniczak et al.
4,669,466 A	6/1987	L'Esperance, Jr.	5,000,751 A	3/1991	Schroder et al.
4,669,839 A	6/1987	Muchel	5,002,571 A	3/1991	O'Donnell, Jr. et al.
4,682,595 A	7/1987	Hoerenz et al.	5,013,311 A	5/1991	Nouri
4,686,979 A	8/1987	Gruen et al.	5,019,074 A	5/1991	Muller
4,686,992 A	8/1987	Dewey et al.	5,041,134 A	8/1991	O'Donnell
4,702,245 A	10/1987	Schroder et al.	5,048,946 A	9/1991	Sklar et al.
4,702,576 A	10/1987	Magnante	5,049,147 A	9/1991	Danon
4,711,540 A	12/1987	Yoshino et al.	5,054,907 A	10/1991	Sklar et al.
4,711,541 A	12/1987	Yoshino et al.	5,057,102 A	10/1991	Tomioka et al.
4,712,543 A	12/1987	Baron	5,067,951 A	11/1991	Greve
4,715,703 A	12/1987	Cornsweet et al.	5,090,798 A	2/1992	Kohayakawa
4,718,418 A	1/1988	L'Esperance, Jr.	5,092,863 A	3/1992	Schanzlin
4,719,912 A	1/1988	Weinberg	5,094,521 A	3/1992	Jolson et al.
4,721,379 A	1/1988	L'Esperance	5,098,426 A	3/1992	Sklar et al.
4,724,522 A	2/1988	Balgorod	5,102,409 A	4/1992	Balgorod
4,729,372 A	3/1988	L'Esperance, Jr.	5,108,388 A	4/1992	Trokel
4,729,373 A	3/1988	Peyman	5,108,412 A	4/1992	Krumeich et al.
4,732,148 A	3/1988	L'Esperance, Jr.	5,112,328 A	5/1992	Taboada et al.
4,732,460 A	3/1988	Kele et al.	5,116,114 A	5/1992	Nakamura et al.
4,736,744 A	4/1988	Koike et al.	5,122,135 A	6/1992	Durr et al.
4,741,612 A	5/1988	Birngruber et al.	5,123,902 A	6/1992	Muller et al.
4,744,362 A	5/1988	Gründler	5,128,509 A	7/1992	Black et al.
4,758,081 A	7/1988	Barnes	5,133,708 A	7/1992	Smith
4,765,336 A	8/1988	Blaha et al.	5,137,530 A	8/1992	Sand
4,770,162 A	9/1988	L'Esperance et al.	5,141,506 A	8/1992	York
4,770,172 A	9/1988	L'Esperance, Jr.	5,147,349 A	9/1992	Johnson et al.
4,770,486 A	9/1988	Wang et al.	5,147,352 A	9/1992	Azema et al.
4,772,116 A	9/1988	Schroder et al.	5,152,055 A	10/1992	L'Esperance, III et al.
4,773,414 A	9/1988	L'Esperance, Jr.	5,152,759 A	10/1992	Parel et al.
4,775,361 A	10/1988	Jacques et al.	5,163,934 A	11/1992	Munnerlyn
4,776,687 A	10/1988	Nakanishi et al.	5,171,242 A	12/1992	Dewey et al.
4,798,204 A	1/1989	L'Esperance, Jr.	5,174,021 A	12/1992	L'Esperance, III et al.
4,820,264 A	4/1989	Matsui et al.	5,178,635 A	1/1993	Gwon et al.
4,830,483 A	5/1989	Kohayakawa et al.	5,188,631 A	2/1993	L'Esperance, Jr.
4,832,043 A	5/1989	Ichihashi	5,194,948 A	3/1993	L'Esperance, III et al.
4,837,857 A	6/1989	Scheller et al.	5,196,006 A	3/1993	Klopotek et al.
4,838,266 A	6/1989	Koziol et al.	5,196,027 A	3/1993	Thompson et al.
4,840,175 A	6/1989	Peyman	5,201,730 A	4/1993	Easley et al.
4,846,172 A	7/1989	Berlin	5,202,708 A	4/1993	Sasaki et al.
4,848,340 A	7/1989	Bille et al.	5,203,353 A	4/1993	Easley et al.
4,854,693 A	8/1989	Ichihashi et al.	5,207,668 A	5/1993	L'Esperance, Jr.
4,856,513 A	8/1989	Muller	5,213,092 A	5/1993	Uram
4,862,888 A	9/1989	Yessik	5,215,104 A	6/1993	Steinert
4,863,261 A	9/1989	Flammer	5,217,459 A	6/1993	Kamerling
4,865,029 A	9/1989	Pankratov et al.	5,219,343 A	6/1993	L'Esperance, Jr.
			5,219,344 A	6/1993	Yoder, Jr.
			5,222,981 A	6/1993	Werblin
			5,224,942 A	7/1993	Beuchat et al.
			5,226,903 A	7/1993	Mizuno

(56)

References Cited

U.S. PATENT DOCUMENTS

5,246,435 A	9/1993	Billie et al.	5,445,633 A	8/1995	Nakamura et al.
5,246,436 A	9/1993	Rowe	5,460,627 A	10/1995	O'Donnell, Jr.
5,257,988 A	11/1993	L'Esperance, Jr.	5,461,212 A	10/1995	Seiler et al.
5,258,025 A	11/1993	Fedorov et al.	5,462,739 A	10/1995	Dan et al.
5,263,950 A	11/1993	L'Esperance, Jr.	5,465,737 A	11/1995	Schachar
5,263,951 A	11/1993	Spears et al.	5,470,329 A	11/1995	Sumiya
5,275,593 A	1/1994	Easley et al.	5,474,548 A	12/1995	Knopp et al.
5,277,911 A	1/1994	Viegas et al.	5,476,511 A	12/1995	Gwon et al.
5,279,298 A	1/1994	Flower	5,480,396 A	1/1996	Simon et al.
5,279,611 A	1/1994	McDonnell et al.	5,484,432 A	1/1996	Sand
5,281,211 A	1/1994	Parel et al.	5,489,299 A	2/1996	Schachar
5,282,798 A	2/1994	Bruse et al.	5,503,165 A	4/1996	Schachar
5,284,477 A	2/1994	Hanna et al.	5,507,740 A	4/1996	O'Donnell, Jr.
5,288,293 A	2/1994	O'Donnell, Jr.	5,514,124 A	5/1996	Alpins
5,290,272 A	3/1994	Burstein et al.	5,514,125 A	5/1996	Lasser et al.
5,295,989 A	3/1994	Nakamura	5,520,679 A	5/1996	Lin
5,300,020 A	4/1994	L'Esperance, Jr.	5,527,774 A	6/1996	Girard
5,300,061 A	4/1994	Easley et al.	5,529,076 A	6/1996	Schachar
5,300,062 A	4/1994	Ueno	5,533,997 A	7/1996	Ruiz
5,300,063 A	4/1994	Tano et al.	5,548,352 A	8/1996	Dewey
5,300,114 A	4/1994	Gwon et al.	5,549,597 A	8/1996	Shimmick et al.
5,304,168 A	4/1994	Sun	5,556,395 A	9/1996	Shimmick et al.
5,304,169 A	4/1994	Sand	5,573,544 A	11/1996	Simon et al.
5,311,224 A	5/1994	Enomoto	D376,207 S *	12/1996	Buczek et al. D24/172
5,312,320 A	5/1994	L'Esperance, Jr.	5,594,753 A	1/1997	Frey et al.
5,312,393 A	5/1994	Mastel	5,607,472 A	3/1997	Thompson
5,314,422 A	5/1994	Nizzola	5,616,139 A	4/1997	Okamoto
5,318,047 A	6/1994	Davenport et al.	5,618,284 A	4/1997	Sand
5,318,560 A	6/1994	Blount et al.	5,620,435 A	4/1997	Belkin et al.
5,323,788 A	6/1994	Silvestrini et al.	5,627,162 A	5/1997	Gwon et al.
5,324,281 A	6/1994	Muller	5,632,742 A	5/1997	Frey et al.
5,325,134 A	6/1994	Kohayakawa	5,651,782 A	7/1997	Simon et al.
5,334,190 A	8/1994	Seiler	5,656,186 A	8/1997	Mourou et al.
5,336,215 A	8/1994	Hsueh et al.	5,684,560 A	11/1997	Roffman et al.
5,336,216 A	8/1994	Dewey	5,699,142 A	12/1997	Lee et al.
5,342,351 A	8/1994	Blaha et al.	5,709,868 A	1/1998	Perricone
5,342,370 A	8/1994	Simon et al.	5,722,952 A	3/1998	Schachar
5,345,948 A	9/1994	O'Donnell, Jr.	5,722,970 A	3/1998	Colvard et al.
5,346,491 A	9/1994	Oertli	5,731,909 A	3/1998	Schachar
5,347,329 A	9/1994	Ota	5,738,677 A	4/1998	Colvard et al.
5,348,551 A	9/1994	Spears et al.	D394,712 S *	5/1998	Henderson et al. D24/160
5,350,374 A	9/1994	Smith	5,752,950 A	5/1998	Frey et al.
5,354,331 A	10/1994	Schachar	5,773,472 A	6/1998	Stjerschantz et al.
5,355,181 A	10/1994	Ashizaki et al.	5,828,686 A	10/1998	Frey et al.
5,356,407 A	10/1994	Easley et al.	5,843,184 A	12/1998	Cionni
5,356,409 A	10/1994	Nizzola	5,849,006 A	12/1998	Frey et al.
D352,106 S *	11/1994	Fanney et al. D24/185	5,886,768 A	3/1999	Knopp et al.
5,360,424 A	11/1994	Klopotek	D410,544 S *	6/1999	Metzler et al. D24/172
5,364,388 A	11/1994	Koziol	5,907,908 A	6/1999	Cunanan et al.
5,364,390 A	11/1994	Taboada et al.	5,912,915 A	6/1999	Reed et al.
5,368,590 A	11/1994	Itoh	5,919,186 A	7/1999	Bath
5,370,641 A	12/1994	O'Donnell, Jr.	5,980,513 A	11/1999	Frey et al.
5,372,595 A	12/1994	Gaasterland et al.	5,984,916 A	11/1999	Lai
5,374,265 A	12/1994	Sand	5,993,441 A	11/1999	Muller et al.
5,376,086 A	12/1994	Khoobehe et al.	6,007,578 A	12/1999	Schachar
5,391,165 A	2/1995	Fountain et al.	6,013,101 A	1/2000	Israel
5,395,356 A	3/1995	King et al.	6,019,472 A	2/2000	Koester et al.
5,403,307 A	4/1995	Zelman	6,022,088 A *	2/2000	Metzler 312/209
5,408,484 A	4/1995	Weimel	6,027,494 A	2/2000	Frey
5,411,501 A	5/1995	Klopotek	6,050,687 A	4/2000	Billie et al.
5,412,561 A	5/1995	Rosenshein et al.	6,055,259 A	4/2000	Frey et al.
5,413,555 A	5/1995	McMahan	6,059,772 A	5/2000	Hsia et al.
5,423,798 A	6/1995	Crow	6,070,981 A	6/2000	Mihashi et al.
5,423,800 A	6/1995	Ren et al.	6,099,522 A	8/2000	Knopp et al.
5,423,801 A	6/1995	Marshall et al.	6,114,651 A	9/2000	Schluter et al.
5,425,727 A	6/1995	Koziol	6,132,424 A	10/2000	Tang
5,425,729 A	6/1995	Ishida et al.	6,186,148 B1	2/2001	Okada
5,425,730 A	6/1995	Luloh	6,190,375 B1	2/2001	Frey
5,437,657 A	8/1995	Epstein	6,197,018 B1	3/2001	O'Donnell, Jr.
5,437,658 A	8/1995	Muller et al.	6,197,056 B1	3/2001	Schachar
5,439,462 A	8/1995	Bille et al.	6,252,595 B1	6/2001	Birmingham et al.
5,441,496 A	8/1995	Easley et al.	6,254,595 B1	7/2001	Juhasz et al.
5,441,511 A	8/1995	hanna	6,261,220 B1	7/2001	Frey et al.
5,442,412 A	8/1995	Frey et al.	6,271,914 B1	8/2001	Frey et al.
5,442,487 A	8/1995	Mizuno	6,271,915 B1	8/2001	Frey et al.
			6,275,718 B1	8/2001	Lempert
			6,280,435 B1	8/2001	Odrich et al.
			6,280,468 B1	8/2001	Schachar
			D447,567 S *	9/2001	Murphy et al. D24/172

(56)

References Cited

U.S. PATENT DOCUMENTS

6,299,640	B1	10/2001	Schachar	7,766,903	B2	8/2010	Blumenkranz et al.
6,302,879	B1	10/2001	Frey et al.	D626,236	S *	10/2010	Ninomiya et al. D24/185
6,312,422	B1	11/2001	Duback	7,836,894	B2	11/2010	Brinkmann et al.
6,312,424	B1	11/2001	Largent	7,959,289	B2	6/2011	Cattin-Liebl
6,313,165	B1	11/2001	Grunberger et al.	D652,520	S *	1/2012	Sabaris Vilas D24/185
6,315,773	B1	11/2001	Frey et al.	D657,469	S *	4/2012	Vilas D24/185
6,319,274	B1	11/2001	Shaddock	8,262,553	B2 *	9/2012	Weston et al. 600/1
6,322,545	B1	11/2001	Schachar	8,262,646	B2	9/2012	Frey et al.
6,322,556	B1	11/2001	Gwon et al.	8,382,745	B2	2/2013	Naranjo-Tackman et al.
6,324,191	B1	11/2001	Horvath	2001/0029363	A1	10/2001	Lin
6,325,791	B1	12/2001	Shimoji	2002/0004658	A1	1/2002	Munnerlyn et al.
6,328,732	B1	12/2001	Donitzky et al.	2002/0025311	A1	2/2002	Till
6,344,040	B1	2/2002	Juhasz et al.	2002/0029053	A1	3/2002	Gordon
6,373,571	B1	4/2002	Juhasz et al.	2002/0049450	A1	4/2002	Myers
D459,806	S	7/2002	Webb	2002/0103478	A1	8/2002	Gwon et al.
D459,807	S	7/2002	Webb	2002/0110549	A1	8/2002	Till
6,413,262	B2	7/2002	Saishin et al.	2002/0138139	A1	9/2002	Till
D462,442	S	9/2002	Webb	2002/0140903	A1	10/2002	Schachar
D462,443	S	9/2002	Webb	2002/0159028	A1	10/2002	Masaki
6,451,008	B1	9/2002	Frey et al.	2003/0050629	A1	3/2003	Kadziauskas et al.
6,460,997	B1	10/2002	Frey et al.	2003/0055412	A1	3/2003	Lieberman et al.
6,467,906	B1	10/2002	Alpins	2003/0076477	A1	4/2003	Matsumoto
D467,001	S *	12/2002	Buczek et al. D24/172	2003/0109926	A1	6/2003	Portney
6,493,151	B2	12/2002	Schachar	2003/0135272	A1	7/2003	Brady et al.
6,494,910	B1	12/2002	Ganem et al.	2003/0139737	A1	7/2003	Lin
6,497,483	B2	12/2002	Frey et al.	2003/0212387	A1	11/2003	Kurtz et al.
6,530,917	B1	3/2003	Seiler et al.	2003/0220630	A1	11/2003	Lin et al.
6,544,254	B1	4/2003	Bath	2004/0054359	A1	3/2004	Ruiz et al.
6,547,394	B2	4/2003	Doherty	2004/0059321	A1	3/2004	Knopp et al.
6,554,825	B1	4/2003	Murray et al.	2004/0070761	A1	4/2004	Horvath et al.
6,585,726	B2	7/2003	Frey et al.	2004/0143244	A1	7/2004	Grey et al.
6,588,902	B2	7/2003	Isogai	2004/0156014	A1	8/2004	Piers et al.
6,588,903	B2	7/2003	Rathjen	2004/0199149	A1	10/2004	Myers et al.
6,610,686	B1	8/2003	Enrico et al.	2004/0199150	A1	10/2004	Lai
6,623,476	B2	9/2003	Juhasz et al.	2004/0243111	A1	12/2004	Bendett et al.
6,626,445	B2 *	9/2003	Murphy et al. 280/47.34	2004/0249403	A1	12/2004	Loomas et al.
6,626,893	B2	9/2003	Frey et al.	2005/0107773	A1	5/2005	Bergt et al.
6,626,894	B2	9/2003	Frey et al.	2005/0107775	A1	5/2005	Huang et al.
6,626,895	B2	9/2003	Frey et al.	2005/0165387	A1	7/2005	Lubatschowski et al.
6,626,896	B2	9/2003	Frey et al.	2005/0197655	A1	9/2005	Telfair et al.
6,626,897	B2	9/2003	Frey et al.	2005/0203492	A1	9/2005	Nguyen et al.
6,626,898	B2	9/2003	Frey et al.	2005/0243276	A1	11/2005	Van Heugten et al.
6,648,877	B1	11/2003	Juhasz et al.	2005/0270486	A1	12/2005	Teiwes et al.
6,669,342	B2	12/2003	Lieberman et al.	2006/0058682	A1	3/2006	Miller et al.
6,676,653	B2	1/2004	Juhasz et al.	2006/0084956	A1	4/2006	Sumiya
6,693,927	B1	2/2004	Horvath et al.	2006/0192921	A1	8/2006	Loesel et al.
6,726,679	B1	4/2004	Dick et al.	2006/0195076	A1	8/2006	Blumenkranz et al.
6,849,091	B1	2/2005	Cumming	2006/0215111	A1	9/2006	Mijashi
6,863,667	B2	3/2005	Webb et al.	2006/0259022	A1	11/2006	Lin
6,905,641	B2	6/2005	Platt et al.	2007/0010803	A1	1/2007	Bischoff et al.
6,923,955	B2	8/2005	Till et al.	2007/0078447	A1	4/2007	Weinacht et al.
6,962,583	B2	11/2005	Kadziauskas et al.	2007/0093795	A1	4/2007	Melcher et al.
7,044,568	B2 *	5/2006	Olivera et al. 312/209	2007/0093796	A1	4/2007	Raksi et al.
7,077,838	B2	7/2006	Wong	2007/0129693	A1	6/2007	Hunter et al.
D530,715	S *	10/2006	Wu D14/371	2007/0173794	A1	7/2007	Frey et al.
7,182,759	B2	2/2007	Kadziauskas et al.	2007/0173795	A1	7/2007	Frey et al.
7,188,949	B2	3/2007	Bandhauer et al.	2007/0185475	A1	8/2007	Frey et al.
7,220,255	B2	5/2007	Lai	2007/0265603	A1	11/2007	Pinelli
7,252,662	B2	8/2007	McArdle et al.	2008/0071254	A1	3/2008	Lummis et al.
7,264,355	B2	9/2007	Rathjen	2008/0111972	A1	5/2008	Barth et al.
D552,242	S *	10/2007	Gutekunst D24/172	2008/0114386	A1	5/2008	Iliakis et al.
RE40,002	E	1/2008	Lin	2008/0186551	A1	8/2008	Hanft et al.
RE40,184	E	3/2008	Lin	2008/0281303	A1	11/2008	Culbertson et al.
7,338,167	B2	3/2008	Zelvin et al.	2008/0281413	A1	11/2008	Culbertson et al.
7,357,504	B2	4/2008	Fischer et al.	2008/0312675	A1	12/2008	Newcott et al.
7,364,575	B2	4/2008	Van Saarloos	2009/0069794	A1	3/2009	Kurtz
D571,011	S *	6/2008	Otoha et al. D24/158	2009/0088734	A1	4/2009	Mordaunt
7,390,089	B2	6/2008	Loesel et al.	2009/0126870	A1	5/2009	Zadoyan et al.
RE40,420	E	7/2008	Dick et al.	2009/0131921	A1	5/2009	Kurtz
7,402,159	B2	7/2008	Loesel et al.	2009/0137988	A1	5/2009	Kurtz
7,467,871	B2 *	12/2008	Lawhorn et al. 351/245	2009/0137991	A1	5/2009	Kurtz
7,540,613	B2	6/2009	Severns	2009/0137993	A1	5/2009	Kurtz
D603,048	S *	10/2009	Fleck et al. D24/185	2009/0161065	A1	6/2009	Smith, III et al.
7,655,002	B2	2/2010	Myers	2009/0171327	A1	7/2009	Kurtz et al.
7,717,908	B2	5/2010	Ruiz et al.	2009/0177189	A1	7/2009	Raksi
				2009/0187178	A1	7/2009	Muller et al.
				2009/0192389	A1	7/2009	Eilers et al.
				2009/0244482	A1	10/2009	Eisner et al.
				2009/0281530	A1	11/2009	Korn

(56)

References Cited

U.S. PATENT DOCUMENTS

2010/0002837	A1	1/2010	Gertner et al.
2010/0004641	A1	1/2010	Frey et al.
2010/0004643	A1	1/2010	Frey et al.
2010/0022994	A1	1/2010	Frey et al.
2010/0022995	A1	1/2010	Frey et al.
2010/0022996	A1	1/2010	Frey et al.
2010/0042079	A1	2/2010	Frey et al.
2010/0060855	A1	3/2010	Graether
2010/0114079	A1	5/2010	Myers et al.
2010/0256614	A1	10/2010	Donitzky et al.
2010/0256615	A1	10/2010	Blumenkranz et al.
2010/0274228	A1	10/2010	Mrochen et al.
2010/0292676	A1	11/2010	Larsen
2010/0292678	A1	11/2010	Frey et al.
2010/0312231	A1	12/2010	Singh
2010/0324542	A1	12/2010	Kurtz
2010/0331829	A1	12/2010	Bor et al.
2011/0022035	A1	1/2011	Porter et al.
2011/0028950	A1	2/2011	Raksi et al.
2011/0092965	A1	4/2011	Slatkine et al.
2011/0118712	A1	5/2011	Lubatschowski et al.
2011/0137301	A1	6/2011	Bartoli
2011/0149240	A1	6/2011	Alpins
2011/0160710	A1	6/2011	Frey et al.
2011/0160711	A1	6/2011	Naranjo-Tackman et al.
2011/0166557	A1	7/2011	Naranjo-Tackman et al.
2011/0184395	A1	7/2011	Schuele et al.
2011/0187995	A1	8/2011	Frey et al.
2011/0190739	A1	8/2011	Frey et al.
2011/0190740	A1	8/2011	Frey et al.
2011/0292340	A1	12/2011	Shimizu et al.
2012/0016350	A1	1/2012	Myers et al.
2012/0182522	A1	7/2012	Frey et al.
2012/0265181	A1	10/2012	Frey
2012/0271286	A1	10/2012	Curatu et al.
2012/0296321	A1	11/2012	Frey et al.
2012/0330290	A1	12/2012	Gray et al.

FOREIGN PATENT DOCUMENTS

EP	0 397 962	A1	11/1990
EP	0 933 060	A1	8/1999
EP	1 970 034	A1	9/2008
FR	2 497 087	A1	7/1982
JP	5-115437	A	5/1993
WO	WO 91/19539	A1	12/1991
WO	WO 01/13838	A1	3/2001
WO	WO 03/002010	A1	1/2003
WO	WO 2005/070358	A1	8/2005
WO	WO 2006/074469	A1	7/2006
WO	WO 2008/112292	A1	9/2008
WO	WO 2012/051490	A1	4/2012

OTHER PUBLICATIONS

U.S. Appl. No. 11/414,819, filed May 1, 2006, Frey et al.
 U.S. Appl. No. 12/217,285, filed Jul. 2, 2008, Frey et al.
 U.S. Appl. No. 12/217,295, filed Jul. 2, 2008, Frey et al.
 U.S. Appl. No. 12/509,021, filed Jul. 24, 2009, Frey et al.
 U.S. Appl. No. 12/509,211, filed Jul. 24, 2009, Frey et al.
 U.S. Appl. No. 12/509,412, filed Jul. 24, 2009, Frey et al.
 U.S. Appl. No. 12/685,850, filed Jan. 12, 2010, Myers et al.
 U.S. Appl. No. 12/831,845, filed Jul. 7, 2010, Naranjo-Tackman et al.
 U.S. Appl. No. 12/831,859, filed Jul. 7, 2010, Naranjo-Tackman et al.
 U.S. Appl. No. 12/840,818, filed Jul. 21, 2010, Porter et al.
 U.S. Appl. No. 12/842,872, filed Jul. 23, 2010, Frey et al.
 U.S. Appl. No. 29/377,018, filed Oct. 15, 2010, Bott et al.
 U.S. Appl. No. 13/016,593, filed Jan. 28, 2011, Frey et al.
 U.S. Appl. No. 13/017,499, filed Jan. 31, 2011, Frey et al.
 U.S. Appl. No. 13/017,702, filed Jan. 31, 2011, Frey et al.
 U.S. Appl. No. 13/243,406, filed Sep. 23, 2011, Myers et al.
 U.S. Appl. No. 13/273,653, filed Oct. 14, 2011, Frey et al.
 U.S. Appl. No. 13/427,130, filed Mar. 22, 2012, Frey.

U.S. Appl. No. 13/427,149, filed Mar. 22, 2012, Frey et al.
 U.S. Appl. No. 13/427,319, filed Mar. 22, 2012, Grey et al.
 U.S. Appl. No. 13/435,103, filed Mar. 30, 2012, Curatu et al.
 U.S. Appl. No. 13/681,004, filed Nov. 19, 2012, Frey et al.
 FDA PMA P040020 titled "AcrySof® ResSTOR® Apodized Diffractive Optic Posterior Chamber Intraocular Lenses, Models MA60d3 and SA60D3", dated Mar. 21, 2005, 29 pgs.
 Unpublished U.S. Appl. No. 13/681,004, filed Nov. 19, 2012 (57 pgs).
 Author unknown, "Statement of the Use of Animals in Ophthalmic and Visual Research", The Association for Research in Vision and Ophthalmology, Obtained from the Internet at: <http://www.arvo.org/aboutavro> as of Nov. 18, 2010, 3 pgs.
 Akchurin, Garif et al., "Evaluation of the degree of turbidity if cataract lens and its correlation with retinal visual acuity", *SPIE*, vol. 3591, Jan. 1999, pp. 74-81.
 Al-Ghoul, K. J. et al., "Distribution and Type of Morphological Damage in Human Nuclear Age-Related Cataracts", *Department of Cell Biology and Anatomy, University of North Carolina and Duke University Eye Center*, 1996, pp. 237-251.
 Al-Ghoul, Kristin J. et al., "Structural Evidence of Human Nuclear Fiber Compaction as a Function of Ageing and Cataractogenesis", *Exp. Eye Res.*, vol. 72, 2001, pp. 199-214.
 Alio, et al., "Crystalline Lens Optical Dysfunction through Aging", *Ophthalmology*, vol. 112, No. 11, Nov. 2005, pp. 2022-2029.
 Amann, Josef et al., "Increased Endothelial Cell Density in the Paracentral and Peripheral Regions of the Human Cornea", *American Journal of Ophthalmology*, vol. 135, No. 5, May 2003, pp. 584-590.
 Amendt, M. Strauss et al., "Modeling of bubble dynamics in relation to medical applications", *Proc. of SPIE*, vol. 2975, 1997, pp. 362-373.
 Ansari, Rafat R. et al., "Measuring lens opacity: combining quasi-elastic light scattering with Scheimpflug imaging system", *Proc. of SPIE*, vol. 3246, 1998, pp. 35-42.
 Anschutz, Till, M.D., "Laser Correction of Hyperopia and Presbyopia", vol. 34, No. 4, 1994, pp. 107-137.
 Apple, David J. et al., "Preparation and Study of Human Eyes Obtained Postmortem with the Miyake Posterior Photographic Technique", *Ophthalmology*, vol. 97, No. 6, Jun. 1990, pp. 810-816.
 Armstrong, Larry "A cataract Breakthrough May Be On The Way", *Business Week*, Mar. 23, 1998, pp. 90-92.
 Aston, Adam, "Why Settle for 20/20?", *Business Week*, Mar. 17, 2003, pp. 95-96.
 Azzam, Naiel et al., "Long-term lens organ culture system to determine age-related effects of Uv irradiation on the eye lens", *Experimental Eye Research*, vol. 79, 2004, pp. 903-911.
 Back, Arthur P. et al., "Correction of Presbyopia with Contact Lenses: Comparative Success Rates with Three Systems", *Optometry & Vision Science*, 1989, vol. 66, No. 8, pp. 518-525.
 Balaram, Mini et al., Noncontact Specular Microscopy of Human Lens Epithelium, *IOVS*, vol. 41, No. 2, Feb. 2000, pp. 474-481.
 Barak, Adiel et al., "Anterior capsulotomy using the CO₂ laser", *Proc. of SPIE*, vol. 3246, 1998, pp. 196-198.
 Bath, Patricia E. et al., "Endocapsular Excimer Laser Phakoablation Through a 1-mm Incision", *Ophthalmic Laser Therapy*, vol. 2, No. 4, 1987, pp. 245-249.
 Beers, A. P. A. et al. "Age-Related Changes in the Accommodation Mechanism", *Optometry and Vision Science*, 1996, vol. 73, No. 4, pp. 235-242.
 Beers, A. P. A. et al., "In Vivo Determination of the Biomechanical Properties of the Component Elements of the Accommodation Mechanism", *Vision Res.*, vol. 34, 1994, pp. 2897-2905.
 Bellows, John G., M.D. et al., "B. Cataracta Complicata", *Traumatic Cataract*, undated but prior to Jul. 2009, pp. 270-272.
 Ben-Sira, I. et al., "Clinical method for measurement of light back scattering from the in vivo human lens", *Invest. Ophthalmol. Vis. Sci.*, vol. 19, No. 4 (Reports), Apr. 1980, pp. 435-437.
 Benjamin, William J., "Borish's Clinical Refraction", W.B. Saunders, publishers, copyright 1998, p. 110.
 Bettelheim, Frederick A. et al., "Synergetic Response of Aging Normal Human Lens to Pressure", *Investigative Ophthalmology & Visual Science*, vol. 44, No. 1, Jan. 2003, pp. 258-263.

(56)

References Cited

OTHER PUBLICATIONS

- Bigler, Emmanuel, "Depth of field and Scheimpflug's rule: a "minimalist" geometrical approach", published unknown, 2002, pp. 1-17.
- Billie, J. F. et al., "3D Imaging of the Human Eye Using The laser Tomographic Scanner Lts", publisher unknown, undated but prior to Jul. 2009, 2 pgs.
- Bito, L.Z. et al., "Age-dependent loss of accommodative amplitude in rhesus monkeys: an animal model for presbyopia", *Invest. Ophthalmol. Vis. Sci.*, vol. 23, No. 1, Jul. 1982, pp. 23-31.
- Bliss, E. S., "Pulse Duration Dependence of laser Damage Mechanisms", *Opto-Electronics*, vol. 3, 1971, pp. 99-108.
- Bor, Zs. PhD., et al., "Plume Emission, Shock Wave and Surface Wave Formation During Excimer Laser Ablation of the Cornea", *Supplement to Retroactive & Corneal Surgery*, vol. 9, Mar./Apr. 1993, pp. S111-S115.
- Borja, David et al., "Crystalline Lens MTF Measurement During Simulated Accommodation", *Proc. of SPIE*, 2005, vol. 5688, pp. 26-32.
- Borkman, Raymond F. et al., "Evidence for a Free Radical Mechanism in Aging and u.v.-Irradiated Ocular Lenses", *Exp. Eye Res.*, 1977, vol. 25, pp. 303-309.
- Braham, Lewis, "Eye Surgery: It's Getting Sharper", *Business Week*, Oct. 18, 2004, pp. 142-143.
- Breitenfeld, P. et al., "Finite Element Method-Simulation of the Human Lens During Accommodation", publisher unknown, vol. 5863, 2005, 9 pgs.
- Breitling, Detlef et al., "Fundamental aspects in machining of metals with short and ultrashort laser pulses", *Proc. of SPIE*, vol. 5339, 2004, pp. 1-15.
- Brian, G. et al., "Cataract Blindness—Challenges For The 21st Century", *Bulletin of the World Health Organization*, vol. 79, No. 3, 2001, pp. 249-256.
- Bron, A.J., "The Ageing Lens", *Ophthalmologica*, vol. 214, 2000, pp. 86-104.
- Brown, Nicholas, "Dating the onset of cataract", *Transactions of the Ophthalmological Society of the United Kingdom*, vol. 96, 1976, pp. 18-23.
- Brown, Nicholas "The Change in Lens Curvature with Age", *Exp. Eye Res.* (1974), vol. 19, pp. 175-183.
- Brown, Nicholas "The Change in Shape and Internal Form of the Lens of the Eye on Accommodation", *Exp. Eye Res.* (1973) vol. 15, pp. 441-459.
- Burd, H.J. et al., "Can reliable values of Young's modulus be deduced from Fisher's (1971) spinning lens measurements?", *Vision Research*, vol. unknown, 2005, pp. 1-15.
- Burd, H.J. et al., "Numerical modeling of the accommodating lens", *Vision Research*, vol. 42, 2002, pp. 2235-2251.
- Campbell, Melanie C. W., "Measurement of Refractive Index in an Intact Crystalline Lens", *Vision Research*, vol. 24, No. 5, 1984, pp. 409-415.
- Carey, James et al., "Propagation and Characterization of Ultrashort Laser Pulses", Harvard University, 2003, pp. 1-30.
- Chaker, M. et al., "Interaction of a 1 psec laser pulse with solid matter", *Phys. Fluids B* 3, vol. 1, Jan. 1991, pp. 167-175, plus cover page.
- Charles, M. W. et al., "Dimensions of the Human Eye Relevant to Radiation Protection", *Phys. Med. Biol.*, 1975, vol. 20, No. 2, © 1975, pp. 202-218.
- Chen, Wei-Li et al., "Ultrasound Biomicroscopic Findings in Rabbit Eyes Undergoing Scleral Suction during Lamellar Refractive Surgery", *IOVS*, vol. 43, No. 12, Dec. 2002, pp. 3665-3672.
- Chien, C. Y. et al., "Production of a high-density and high-temperature plasma with an intense high-contrast subpicosecond laser", *Optics Letters*, vol. 18, No. 18, Sep. 15, 1993, pp. 1535-1537.
- Claffin, E. S. et al., "Configuring an electrostatic membrane mirror by least-squares fitting with analytically derived influence functions", *J. Opt. Soc. Am. A.*, vol. 3, No. 11, 1986, pp. 1833-1839.
- Coleman, D. Jackson et al., "Presbyopia, Accommodation, and the Mature Catenary", *Ophthalmology*, vol. 108, No. 9, Sep. 2001, pp. 1544-1551.
- Cook, Christopher A. et al., "Aging of the Human Crystalline Lens and Anterior Segment", *Vision Res.*, 1994, vol. 34, No. 22, pp. 2945-2954.
- Corkum, P. B. et al., "Thermal Response of Metals to Ultrashort-Pulse Laser Excitation", *Physical Review Letters*, vol. 61, No. 25, Dec. 19, 1988, pp. 2886-2889.
- Costagliola, Ciro et al., "ArF 193 nm Excimer Laser Corneal Surgery as a Possible Risk Factor in Cataractogenesis", *Exp. Eye Res.*, 1994, vol. 58, pp. 453-457.
- Cotlier, Edward, M.D., "The Lens", *Adler's Physiology of the Eye*, copyright 2003, pp. 268-290.
- Crawford, Kathryn S. et al., "The Role of the Iris in Accommodation of Rhesus Monkeys", *Investigative Ophthalmology & Visual Science*, vol. 31, No. 10, Oct. 1990, pp. 2185-2190.
- Croft, Mary Ann et al., "Accommodation and Presbyopia", publisher unknown, vol. 41, 2001, pp. 33-46.
- Croft, Mary Ann et al., "Accommodation and Presbyopia: The Ciliary Neuromuscular View", *Ophthalmol Clin N Am*, vol. 19, 2006, pp. 13-24.
- Croft, Mary Ann et al., "Accommodative Ciliary Body and Lens Function in Rhesus Monkeys, I: Normal Lens, Zonule and Ciliary Process Configuration in the Iridectomized Eye", *IOVS*, vol. 47, No. 3, Mar. 2006, pp. 1076-1086.
- Croft, Mary Ann et al., "The Zonula, Lens, and Circumferential Space in the Normal Iridectomized Rhesus Monkey Eye", *IOVS*, vol. 47, No. 3, Mar. 2006, pp. 1087-1095.
- Cromie, William J., "Laser Makes History's Fastest Holes", *The Harvard University Gazette*, 1999, obtained at: <http://www.news.harvard.edu/gazette/1999/10.07/laser.html>, 6 pgs.
- Czygan, G. et al., "Mechanical testing of isolated senile human eye lens nuclei", *Med. Eng. Phys.*, vol. 18, No. 5, 1996, pp. 345-349.
- Datta, Debajyoti, "Tissue Surgery and Subcellular Photodisruption with Femtosecond Laser Pulses", *Thesis for Dept. of Physics*, Harvard University, May 2002, pp. 1-74.
- Dausinger, Friedrich et al., "Micro-machining with ultrashort laser pulses: From basic understanding to technical applications", publisher unknown, undated but prior to Jul. 2009, pp. 1-10.
- Dholakia, Sheena A. et al., "Prospective evaluation of phacoemulsification in adults younger than 50 years", *J Cataract Refract Surg*, vol. 31, 2005, pp. 1327-1333.
- Douven, Lucien F.A. et al., "Characterization of Mechanical Behaviour of Human Skin in Vivo", *Proc. Of Spie*, vol. 3914, 2000, pp. 618-629.
- Du, D. et al., "Laser-induced breakdown by impact ionization in SiO₂ with pulse widths from 7 ns to 150 fs", *Appl. Phys. Lett.*, vol. 64, No. 23, Jun. 6, 1994, pp. 3071-3073.
- Ehrmann, Klaus et al., "Evaluation of porcine crystalline lenses in comparison with molded polymer gel lenses with an improved ex vivo accommodation simulator", *Proc. of Spie*, vol. 5688, 2005, pp. 240-251.
- Ehrmann, Klaus et al., "Ex Vivo Accommodation Simulator II—Concept and Preliminary Results", *Proc. of SPIE*, vol. 5314, 2004, pp. 48-58.
- Eisner, Georg, "Eye Surgery—An Introduction to operative technique", Springer-Verlag, Berlin, 1980, pp. 14-19.
- Ei-Osta, Austen A.R. et al., "In vitro model for the study of human posterior capsule opacification", *J Cataract Refract Surg*, vol. 29, 2003, pp. 1593-1600.
- Erpelding, Todd N. et al., "Bubble-Based Acoustic Radiation Force for Monitoring Intraocular Lens Elasticity", *IEEE Intl Ultrasonics Symposium*, vol. unknown, 2004, pp. 732-735.
- Fagerholm, Per P.P., "The Response of the Lens to Trauma", *Trans. Ophthal. Soc. U. K.*, 1982, vol. 102, p. 369-374.
- Farnsworth, P.N. et al., "Anterior Zonular Shifts with Age", *Exp. Eye Res.*, vol. 28, 1979, pp. 291-297.
- Findl, Oliver et al., "Laserinterferometric Assessment of Pilocarpine-Induced Movement of an Accommodating Intraocular Lens—A Randomized Trial", *Ophthalmology*, vol. 111, No. 8, Aug. 2004, pp. 1515-1521.

(56)

References Cited

OTHER PUBLICATIONS

- Fisher, R.F. et al., "Changes in lens fibres after damage to the lens capsule", publisher unknown, undated but prior to Jul. 2009, 4 pgs.
- Fisher, R.F., "Elastic Constants of the Human Lens Capsule", *J. Physiol.*, vol. 201, 1969, pp. 1-19.
- Fisher, R.F., "Presbyopia And The Changes With Age In The Human Crystalline Lens", *J. Physiol.*, vol. 228, 1973, pp. 765-779.
- Fisher, R. F., "The Ciliary Body in Accommodation", *Trans. Ophthalmol. Soc. U.K.*, vol. 105, 1986, pp. 208-219.
- Fisher, R.F., "The Elastic Constants of The Human Lens", *J. Physiol.*, vol. 212, 1971, pp. 147-180.
- Fisher, R. F. et al., "The elastic constants and ultrastructural organization of a basement membrane (lens capsule)", *Proc. R. Soc. Lond. B.*, vol. 193, 1976, pp. 335-358.
- Fisher, R.F., "The Force of Contraction of the Human Ciliary Muscle During Accommodation", *J. Physiol.*, vol. 270, 1977, pp. 51-74.
- Fisher, R. F., "The Mechanics of Accommodation in Relation to Presbyopia", *Eye*, vol. 2, 1988, pp. 646-649.
- Fleck, Brian W. et al., "Q-switched Nd:YAG laser disruption of rabbit lens nucleus", *Laser and Light in Ophthalmology*, 1990, vol. 3. No. 3, pp. 227-232.
- Foster, C. Stephen et al., "Smolin and Thoft's The Cornea: Scientific Foundations and Clinical Practice", *The New England Journal of Medicine*, vol. 353 No. 23, 2005, pp. 2519-2520.
- Fujimoto, James et al., "Biomedical Optics", Photonics West, *Proc. of SPIE*, vol. unknown, 2005, pp. 23-70.
- Garner, LF et al., "Changes in Equivalent and Gradient Refractive Index of the Crystalline Lens with Accommodation", *Optom. Vis. Sci.*, vol. 74, No. 2, Feb. 1997, pp. 114-119.
- Garner, LF et al., "Changes in Ocular Dimensions and Refraction with Accommodation", *Ophthalm. Physiol. Opt.*, vol. 17, No. 1, 1997, pp. 12-17.
- Garner, Margaret H. et al., "Selective oxidation of cysteine and methionine in normal and senile cataractous lenses", *Proc. Natl. Acad. Sci. USA*, vol. 77, No. 3, Mar. 1980, pp. 1274-1277.
- Gayen, Tapan K. et al., "Near-infrared laser welding of aortic and skin tissues and microscopic investigation of welding efficacy", *Proc. of SPIE*, vol. 4949, 2003, pp. 182-185.
- Gershenzon, A. et al., "Clinical and Epidemiology—New software for lens retro-illumination digital image analysis", *Australian and New Zealand Journal of Ophthalmology*, 1999, vol. 27, pp. 170-172.
- Giblin, Frank J. et al., "Nuclear Light Scattering, Disulfide Formation and Membrane Damage in Lenses of Older Guinea Pigs Treated with Hyperbaric Oxygen", *Exp. Eye Res.*, 1995, vol. 60, pp. 219-235.
- Gills, James P., "Treating astigmatism at the time of cataract surgery", *Current Opinion in Ophthalmology*, 2002, vol. 13, p. 2-6.
- Gimbel, Howard V. et al., "Intrastromal Photorefractive Keratectomy with the Nd:YLF Laser", publisher unknown, vol. 34, Iss. 4, 1994, pp. 139-145.
- Glasser, Adrian et al., "Accommodative Changes in Lens Diameter in Rhesus Monkeys", *IOVS*, vol. 47, No. 1, Jan. 2006, pp. 278-286.
- Glasser, A. et al., "Biometric, optical and physical changes in the isolated human crystalline lens with age in relation to presbyopia", *Vision Research*, vol. 39, 1999, pp. 1991-2015.
- Glasser, Adrian et al., "On modeling the causes of presbyopia", *Vision Research*, vol. 41, 2001, pp. 3083-3087.
- Glasser, A. et al., "On the potential causes of presbyopia", *Vision Research*, vol. 39, 1999, pp. 1267-1272.
- Glasser, Adrian et al., "Presbyopia and the Optical Changes in the Human Crystalline Lens with Age", *Vision Res.*, vol. 38, No. 2, 1998, pp. 209-229.
- Glasser, Adrian et al., "Ultrasound Biomicroscopy of the Aging Rhesus Monkey Ciliary Region", *Optometry and Vision Science*, vol. 78, No. 6, 2001, pp. 417-424.
- Goodenough, Daniel A., "Lens gap junctions: a structural hypothesis for nonregulated low-resistance intercellular pathways", *Invest. Ophthalmol. Visual Sci.*, vol. 18, No. 11, Nov. 1979, pp. 1104-1122.
- Grace, Jeffery M. et al., "Repetitively Pulsed Ruby Lasers As Light Sources for High-Speed Photography", *Optical Engineering*, vol. 37, No. 8, Aug. 1998, pp. 1-26.
- Gwon, Arlene et al., "Focal laser photophacoablation of normal and cataractous lenses in rabbits: Preliminary report", *J Cataract Refract Surg*, vol. 21, May 1995, pp. 282-286.
- Habib, Maged S. et al., "Myopic Intrastromal Photorefractive Keratectomy With the Neodymium-Yttrium Lithium Fluoride Pico-second Laser in the Cat Cornea", *Arch Ophthalmol.*, vol. 113, Apr. 1995, pp. 499-505.
- Hahn, D.W., "Dynamics of Ablation Plume Particles Generated During Excimer Laser Corneal Ablation", *Lasers in Surgery and Medicine*, vol. 16, 1995, pp. 384-389.
- Hamaoui, Marie et al., "Ex-vivo testing of crystalline lens substitutes: a pilot study", *Proc. of SPIE*, vol. 3908, 2000, pp. 123-130.
- Hammer, Daniel X. et al., "Dual Octislo Imager with Three-Dimensional Tracker", *Proc. of SPIE*, vol. 5688, 2005, pp. 33-44.
- Hammer, Daniel et al., "Shielding Properties of Laser-Induced Breakdown in Water for Pulse Durations From 5 ns to 125 fs", *Applied Optics*, 1997, vol. 36, No. 22, pp. 5630-5640.
- Hanson, S.R.A. et al., "The major in vivo modifications of the human water-insoluble lens crystallins are disulfide bonds, deamidation, methionine oxidation and backbone cleavage", *Exp. Eye Res.*, vol. 71, 2000, pp. 195-207.
- Hara, Tsutomu, M.D. et al., "Complications associated with endocapsular balloon implantation rabbit eyes", *J Cataract Refract Surg*, vol. 20, Sep. 1994, pp. 507 and 512.
- Harding, J. J., "Disulphide Cross-linked Protein of High Molecular Weight in Human Cataractous Lens", *Exp. Eye Res.* (1973), vol. 17, pp. 377-383.
- Hartwick, Andrew T. E. et al., "Epithelial activity of hexokinase and glucose-6-phosphate dehydrogenase in cultured bovine lenses recovering from pharmaceutical-induced optical damage", *Molecular Vision*, vol. 9, 2003, pp. 594-600.
- Heisterkamp, Alexander et al., "Nonlinear effects inside corneal tissue after fs-photodisruption", *Proc. of SPIE*, vol. 4433, 2001, pp. 55-60.
- Heisterkamp, Alexander et al., "Pulse energy dependence of subcellular dissection by femtosecond laser pulses", *Optics Express*, vol. 13, No. 10, May 2005, pp. 3690-3696.
- Hemenger, Richard P. et al., "Change With Age of the Refractive Index Gradient of the Human Ocular Lens", *Investigative Ophthalmology & Visual Science*, Mar. 1995. vol. 36, No. 3. pp. 703-707.
- Heys, Karl Robert et al., "Massive increase in the stiffness of the human lens nucleus with age: the basis for presbyopia?", *Molecular Vision*, vol. 10, 2004, pp. 956-963.
- Ho, A. et al., "Feasibility of simultaneous correction of ametropia by varying gel refractive index with phaco-ersatz", *Proc. of SPIE*, vol. 4245, 2001, pp. 119-128.
- Hoffman, Richard S. et al., "Refractive lens exchange as a refractive surgery modality", Copyright© 2004 Lippincott Williams & Wilkins, pp. 22-28.
- Holzer, Mike P. et al., "Corneal flap complications in refractive surgery—Part 1: Development of an experimental animal model", *J Cataract Refract Surg*, vol. 29, Apr. 2003, pp. 795-802.
- Holzer, Mike P. et al., "Corneal flap complications in refractive surgery—Part 2: Postoperative treatments of diffuse lamellar keratitis in an experimental animal model", *J Cataract Refract Surg*, vol. 29, Apr. 2003, pp. 803-807.
- Horwitz, Joseph, "α-Crystallin can function as a molecular chaperone", *Proc. Natl. Acad. Sci. USA*, vol. 89. Nov. 1992, pp. 10449-10453.
- Hu, Tian-Sheng et al., "Reversal of Galactose Cataract with Sorbinil in Rats", *Investigative Ophthalmology & Visual Science*, May 1983, vol. 24, pp. 640-644.
- Huber, G. et al., "Room-temperature 2-μm HO:YAG and 3-μm ER:YAG Lasers", *Journal de Physique*, undated but prior to Jul. 2009, 3 pgs.
- Hunter, David, "First, Gather the Data", *New England Journal of Medicine*, vol. 354, No. 4, Jan. 26, 2006, pp. 329-331.
- Jacques, Paul F. et al., "Long-term vitamin C supplement use and prevalence of early age-related lens opacities", *Am J Clin Nutr*, 1997; 66, pp. 911-6.
- Johannesson, Mattias, "Active Range Imaging 2", PhD-Thesis: SIMD architectures for Range and Radar Imaging, *Linkoping Studies in Science and Technology*, Dissertations No. 399, 2005, pp. 1-34.

(56)

References Cited

OTHER PUBLICATIONS

- Jones, C.E. et al., "Refractive index distribution and optical properties of the isolated human lens measured using magnetic resonance imaging (MRI)", *Vision Research*, vol. 45, 2005, pp. 2352-2366.
- Juhasz, Tibor, Ph.D. et al., "Dynamics of Shock Waves and Cavitation Bubbles Generated by Picosecond Laser Pulses in Corneal Tissue and Water", *Lasers in Surgery and Medicine*, vol. 15, 1994, pp. 91-98.
- Juhasz, T. et al., "Time resolved observations of shock waves and cavitatin bubbles generated by femtosecond laser pulses in corneal tissue and water", *Lasers in Surgery and Med*, vol. 19, 1996, pp. 23-31.
- Juhasz, T. et al., "Time-resolved Studies of Plasma-Mediated Surface Ablation of Soft Biological Tissue with Near-Infrared Picosecond Laser Pulses", *SPIE*, vol. 2975, 1997, pp. 271-281.
- Kasthurirangan, Sanjeev et al., "Amplitude dependent accommodative dynamics in humans", *Vision Research*, vol. 43, 2003, pp. 2945-2956.
- Kasthurirangan, Sanjeev, "Influence of Amplitude and Starting Point on Accommodative Dynamics in Humans", *IOVS*, vol. 46, No. 9, Sep. 2005, pp. 3463-3472.
- Kaufman, Paul L., M.D., "Accommodation and Presbyopia: Neuromuscular and Biophysical Aspects", *Adler's Physiology of the Eye*, date unknown but prior to Jul. 2009, pp. 391-411.
- Klem, D. E. et al., "The Interaction of Intense Femtosecond Laser Pulses with Solid Targets", paper prepared under the auspices of the U.S. Dept. of Energy for the Short Wavelength V: Physics with Intense Laser Pulses Second Topical Meeting on Mar. 29-31, published December 30, 1992, 1993, 6 pgs.
- Keeney, Arthur H., M.D., "Intralenticular Foreign Bodies", *Arch Ophthalmol.*, vol. 86, Nov. 1971, pp. 499-501.
- König, Karsten et al., "Are Femtosecond Lasers Safe for Ophthalmic Applications?", *Fraunhofer Institute of Biomedical Technologies*, undated but prior to Jul. 2009, pp. 1-16.
- König, Karsten et al., "Cornea surgery with nanojoule femtosecond laser pulses", *Proc. of SPIE*, vol. 5688, 2005, pp. 288-293.
- Emig, Karsten et al., "First in vivo animal studies on intraocular nanosurgery and multiphoton tomography with low-energy 80 MHz near infrared femtosecond laser pulses", *Proc. Of Spie*, vol. 5314, 2004, pp. 262-269.
- Koopmans, Steven A. et al., "Polymer Refilling of Presbyopic Human Lenses In Vitro Restores the Ability to Undergo Accommodative Changes", *IOVS*, vol. 44, No. 1, Jan. 2003, pp. 250-257.
- Koretz, Jane F. et al., "A Model for Accommodation in the Young Human Eye: The Effects of Lens Elastic Anisotropy on the Mechanism", *Vision Res.*, vol. 23, No. 12, 1983, pp. 1679-1686.
- Koretz, Jane F. et al., "Accommodation and Presbyopia in The Human Eye—Aging of the Anterior Segment", *Vision Res.*, vol. 29, No. 12, 1989, pp. 1685-1692.
- Koretz, Jane F. et al., "Accommodation and Presbyopia in the Human Eye - Changes in the Anterior Segment and Crystalline Lens With Focus", *IOVS*, vol. 38, No. 3, Mar. 1997, pp. 569-578.
- Koretz, Jane F. et al., "Analysis of Human Crystalline Lens Curvature as a Function of Accommodative State and Age", *Vision Res.*, vol. 24, No. 10, 1984, pp. 1141-1151.
- Koretz, Jane F. et al., "How the Human Eye Focuses", *Scientific American*, Jul. 1988, pp. 92-99.
- Koretz, Jane F. et al., "Model of the Accommodative Mechanism in The Human Eye", *Vis. Res.*, vol. 22, 1982, pp. 917-927.
- Koretz, Jane F. et al., "Scheimpflug and high-resolution magnetic resonance imaging of the anterior segment: a comparative study", *J. Opt. Soc. Am. A*, vol. 21, No. 3, Mar. 2004, pp. 346-354.
- Koretz, Jane F. et al., "The Zones of Discontinuity in the Human Lens: Development and Distribution with Age", *Vision Res.*, vol. 34, No. 22, 1994, pp. 2955-2962.
- Krag, Susanne et al., "Biomechanical Characteristics of the Human Anterior Lens Capsule in Relation to Age", *Investigative Ophthalmology & Visual Science*, vol. 38, No. 2, Feb. 1997, pp. 357-362.
- Krag, Susanne, "Biomechanical measurements of the lens capsule", *Scandinavian University Theses*, 1999, 3 pgs.
- Krag, Susanne et al., "Mechanical Properties of the Human Posterior Lens Capsule", *IOVS*, vol. 44, No. 2, 2003, pp. 691-696.
- Krauss, Joel et al., "Laser Interactions With the Cornea", *Survey of Ophthalmology* A679, vol. 31, No. 1, Jul./Aug. 1986, pp. 37-53.
- Kronemyer, Bob, "Accommodating IOL? Impossible, Recent Study Seems To Say", *Ocular Surgery News*, <http://www.slackmc.com> Sep. 15, 1996, 2 pgs.
- Krueger, Ronald R. et al., "Experimental Increase in Accommodative Potential after Neodymium: Yttrium-Aluminum-Garnet Laser Photodisruption of Paired Cadaver Lenses", *Ophthalmology*, vol. 108, No. 11, 2001, pp. 2122-2129.
- Krueger, Ronald R. et al., "First safety study of femtosecond laser photodisruption in animal lenses: Tissue morphology and cataractogenesis", *J Cataract Refract Surg*, vol. 31, Dec. 2005, pp. 2386-2394.
- Krueger, Ronald R., M.D., et al., "Nonmechanical Microkeratomes Using Laser and Water Jet Technology", Publisher unknown, date unknown but prior to Jul. 2009, pp. 1-33.
- Krueger, R.R., "Surf's Up—Catch a wave with a waterjet", *Jrn. Ref. Surg.*, vol. 14, No. 3, May/June. 1998, pp. 280-281.
- Krueger, Ronald R., M.D. et al., "Ultrastructure of Picosecond Laser Intrastromal Photodisruption", *Journal of Refractive Surgery*, vol. 12, Jul./Aug. 1996, pp. 607-612.
- Kuizenga, Dirk J., "FM-Laser Operation of the Nd:YAG Laser", *IEEE Journal of Quantum Electronics*, vol. 6, No. 11, 1970, pp. 673-677.
- Kurapkienė, S. et al., "The relationship of ultrasonic and mechanical properties of human nuclear cataract. A pilot study", *Ultragarsas*, vol. 54, No. 1, 2005, pp. 39-43.
- Kurtz, Ron et al., "Femtosecond Laser Corneal Refractive Surgery", *Proc. of SPIE*, vol. 3591, 1999, pp. 209-219.
- Kurtz, Ron et al., "Ophthalmic Applications of Femtosecond Lasers", *Proc. f SPIE*, vol. 3616, 1999, pp. 51-65.
- Kurtz, Ron M. et al., "Optimal Laser Parameters for Intrastromal Corneal Surgery", *Proc. of SPIE*, vol. 3255, 1998, pp. 56-66.
- Kurtz, Ron M., MD, et al., "Photo-disruption in the Human Cornea as a Function of Laser Pulse Width", *Journal of Refractive Surgery*, vol. 13, Nov./Dec. 1997, pp. 653-658.
- Kuszek, J. R. et al., "A Quantitative Analysis of Sutural Contributions to Variability in Back Vertex Distance and Transmittance in Rabbit Lenses as a Function of Development, Growth, and Age", *Optometry and Vision Science*, vol. 79, No. 3, Mar. 2002, pp. 193-204.
- Kuszek, J. R. et al., "Anatomy of Aged and Senile Cataractous Lenses", from "Biochemistry of the Crystalline Lens", undated but prior to Jul. 2009, pp. 564-575.
- Kuszek, J. R. et al., "Biochemistry of the Crystalline Lens; Anatomy of Aged and Senile Cataractous Lenses", pp. 564-575.
- Kuszek, J. R. et al., "Development of lens sutures", *Int. J. Dev. Biol.*, vol. 48, 2004, pp. 889-902.
- Kuszek, J. R. et al., "Electron Microscope Observations of the Crystalline Lens", *Microscopy Research and Technique*, 1996, vol. 33, pp. 441-479.
- Kuszek, J. R. et al., "Fibre cell organization in crystalline lenses", *Experimental Eye Research*, vol. 78, 2004, pp. 673-687.
- Kuszek, J. et al., "Gap Junctions of Chick Lens Fiber Cells", *Exp. Eye Res.*, vol. 27, 1978, pp. 495-498.
- Kuszek, J. R. et al., "Lens Optical Quality and Lens Sutures", *Investigative Ophthalmology & Visual Science*, vol. 32, No. 7, Jun. 1991, pp. 2123-2129.
- Kuszek, J. R. et al., "Lens Optical Quality is a Direct Function of Lens Sutural Architecture", *Investigative Ophthalmology & Visual Science*, vol. 32, No. 7, Jun. 1991, pp. 2119-2129.
- Kuszek, J. R. et al., "Quantitative Analysis of Animal Model Lens Anatomy: Accommodative Range is Related to Fiber Structure and Organization", undated but prior to Jul. 2009, 26 pgs.
- Kuszek, J. R. et al., "Suppression of Post-Vitrectomy Lens Changes in the Rabbit by Novel Benzopyranyl Esters and Amides", *Exp. Eye Res.*, vol. 75, 2002, pp. 459-473.
- Kuszek, JR et al., "The interrelationship of lens anatomy and optical quality II Primate Lenses", *Exp. Eye Res.*, vol. 59, 1994, pp. 521-535.
- Kuszek, J. R. et al., "The Relationship Between Rabbit Lens Optical Quality and Sutural Anatomy after Vitrectomy", *Exp. Eye Res.*, vol. 71, 2000, pp. 267-281.

(56)

References Cited

OTHER PUBLICATIONS

- Kuszak Jer R. et al., "The Structure of the Vertebrate Lens", Chapter 4, undated but prior to Jul. 2009, pp. 71-118.
- Kuszak, J. et al., "The Surface Morphology of Embryonic and Adult Chick Lens-Fiber Cells", *The American Journal of Anatomy*, vol. 159, 1982, pp. 395-410.
- Kuszak, J. R. et al., "The Use of An Ex Vivo Mechanical Stretching Apparatus To Examine Fiber Ultrastructure During Accommodation", undated but prior to Jul. 2009, 1 pg.
- Kuwabara, Toichiro, et al., "Electron Microscopic Study of Galactose-Induced Cataract", *Investigative Ophthalmology*, vol. 8, No. 2, Apr. 1969, pp. 133-149.
- L'Esperance, Jr. "Ophthalmic Lasers Photocoagulation, Photoradiation and Surgery", 2nd Edition, The C.V. Mosby Company, copyright 1983, pp. 529-538.
- Lerman, Sidney, et al., "A Method for Detecting 8-Methoxypsoralen in the Ocular Lens", *Science*, vol. 197, Sep. 23, 1977, 1287-1288.
- Lerman, Sidney, et al., "Photosensitization of the lens by 8-methoxypsoralen", *Invent. Ophthalmol. Visual Sci.*, vol. 16, No. 11, Nov. 1977, pp. 1065-1068.
- Lerman, Sidney, M.D., "Photosensitizing Drugs and Their Possible Role in Enhancing Ocular Toxicity", *Ophthalmology*, vol. 93, No. 3, Mar. 1986, pp. 304-318.
- Lerman, Sidney, et al., "Psoralen-long-wave Ultraviolet Therapy and Human Cataractogenesis", *Invent. Ophthalmol. Visual Sci.*, vol. 23, No. 6, Dec. 1982, pp. 801-804.
- Lerman, Sidney, et al., "Spectroscopic Evaluation and Classification of the Normal, Aging, and Cataractous Lens", *Ophthl. Res.*, vol. 8, 1976, pp. 335-353.
- Lim, Seung Jeong, M.D. et al., "Analysis of zonular-free zone and lens size in relation to axial length of eye with age", *J Cataract Refract Surg*, vol. 24, Mar. 1998, pp. 390-396.
- Liu, X. et al., "Competition between Ponderomotive and Thermal Forces in Short-Scale-Length Laser Plasmas", *Physical Review Letters*, vol. 69, No. 13, Sep. 28, 1992, pp. 1935-1938.
- Liu, Xinbing et al., "In vivo plasma-mediated ablation as a function of laser pulse width", *SPIE*, vol. 2975, 1997, pp. 282-288.
- Loerscher, Hanspeter et al., "Noncontact Trephination of the Cornea Using a Pulsed Hydrogen Fluoride Laser", *American Journal of Ophthalmology*, vol. 104, Nov. 1987, pp. 471-475.
- Loesel, Frieder H. et al., "Laser-Induced Optical Breakdown on Hard and Soft Tissues and Its Dependence on the Pulse Duration: Experiment and Model", *IEEE Journal of Quantum Electronics*, vol. 32, No. 10, Oct. 1996, pp. 1717-1722.
- Lou, Marjorie F., et al., "Protein-Thiol Mixed Disulfides in Human Lens", published by Academic Press Limited, 1992, pp. 889-896.
- Lubatschowski, Holger, "Surgical Laser System for the Treatment of Presbyopia", 7th Biotech in Europe Investor Forum, Switzerland, Oct. 2-3, 2007, 9 pgs.
- Lute, Margaret et al., "Lenses of Diabetic Patients "Yellow" at an Accelerated Rate Similar to Older Normals", *Investigative Ophthalmology & Visual Science*, vol. 32, No. 1, Jan. 1991, pp. 194-199.
- Maguen, Ezra, et al., "Excimer Laser Ablation of the Human Lens at 308 nm with a Fiber Delivery System", *J. Cataract Refract Surg.*, vol. 15, Jul. 1989, pp. 409-414.
- Manns, Fabrice et al., "Radius of Curvature and Asphericity of the Anterior and Posterior Surface of Human Cadaver Crystalline Lenses", *Experimental Eye Research*, 2004, vol. 78, pp. 39-51.
- Marion, II, John E. et al., "Medical Applications of Ultra-Short Pulse Lasers", *Proc. of SPIE*, vol. 3616, 1999, pp. 42-50.
- Masters, B.R., "Three-dimensional Microscopic Tomographic Imaging of the Cataract in a Human Lens In Vivo", *Optics Express* 332, vol. 3, No. 9, Oct. 1998, pp. 332-338.
- Mathias, R.T. et al., "Physiological Properties of the Normal Lens", *Physiological Reviews*, vol. 77, No. 1, Jan. 1997, pp. 21-50.
- McBrien, N. A et al., "Experimental Myopia in a Diurnal Mammal (*Sciurus carolinensis*) with No Accommodative Ability", *J. Physiol.*, vol. 469, 1993, pp. 427-441.
- McCourt, M. E et al., Refractive State, Depth of Focus, and Accommodation of the Eye of the California ground squirrel (*Spermophilus beecheyi*), *Vision Res*, vol. 24, No. 10, 1984, pp. 1261-1266.
- McDonald, Marguerita B., et al., "Central Photorefractive Keratectomy for Myopia, The Blind Eye Study", *Arch Ophthalmol*, vol. 108, Jun. 1990, pp. 799-808.
- Michael, Ralph et al., "Refractive Index of Lens Fiber Membranes in Different Parts of the Crystalline Lens", *Proceedings of SPIE*, vol. 4611, 2002, pp. 159-164.
- Moffat, B.A. et al., "Age-Related Changes in Refractive Index Distribution and Power of the Human Lens as Measured by Magnetic Resonance Micro-Imaging In Vitro", *Vision Research*, vol. 42, 2002, pp. 1683-1693.
- Muller, F. et al., "A Comparative Study of Deposition of Thin Films by Laser Induced PVD with Femtosecond and Nanosecond Laser Pulses", *SPIE*, vol. 1858, 1993, pp. 464-474.
- Mutti, Donald O., et al., "A Video Technique for Phakometry of the Human Crystalline Lens", *Investigative Ophthalmology, & Visual Science*, vol. 33, No. 5, Apr. 1992, pp. 1771-1781.
- Myers, Raymond I. et al., "Feasibility of Using Lasers to Retard Cataract Development in the Ocular Lens by Restoring Lens Movement"; undated but prior to Jul. 2009, pp. 1-22.
- Myers, Raymond I. et al., "Novel Approaches to Correction of Presbyopia With Laser Modification of the Crystalline Lens", *Journal of Refractive Surgery*, vol. 14, Mar./Apr. 1998, pp. 136-139.
- Nanevich, Tania M., et al., "Excimer Laser Ablation of the Lens", *Arch Ophthalmol*, vol. 104, Dec. 1986, pp. 1825-1829.
- Neev, Joseph, "Ultrashort Pulse Lasers: A New Tool for Biomedical Applications", *SPIE*, vol. 3255, pp. 2-7.
- Nichamin, Louis D., "Treating astigmatism at the time of cataract surgery", *Current Opinion in Ophthalmology*, 2003, vol. 14, p. 35-38.
- Oberheide, Uwe et al., "Therapy Monitoring of Laser Cyclophotocoagulation", *Proceedings of SPIE*, vol. 4611, 2002, pp. 48-53.
- O'Donnell, Colleen B., et al., "Ablation Smoothness as a Function of Excimer Laser Delivery System", *J. Cataract Refract Surg.*, vol. 22, Jul./Aug. 1996, pp. 682-685.
- O'Donnell, Colleen B., et al., "Surface Roughness in Pmma is Linearly Related to the Amount of Excimer Laser Ablation", *Journal of Refractive Surgery*, vol. 12, Jan./Feb. 1996, pp. 171-174.
- Oriowo, Olanrewaju Matthew, "A Study of Ultraviolet Radiation Effects on Procine Crystalline Lens and Development of a New Assay Methodology for UV Cataractogenesis Investigation", *A Thesis Presented to the University of Waterloo*, 2000, pp. i-xix and 1-218.
- Ostrin, Lisa A. et al., "Comparisons Between Pharmacologically and Edinger-Westphal-Stimulated Accommodation in Rhesus Monkeys", *Investigative Ophthalmology & Visual Science*, 2005, vol. 46, No. 2, pp. 609-617.
- Ostrin, Lisa A. et al., "Effects of Pirenzepine on Pupil Size and Accommodation in Rhesus Monkeys", *Investigative Ophthalmology & Visual Science*, Oct. 2004, vol. 45, No. 10, pp. 3620-3628.
- Ostrin, Lisa A. et al., "The Effects of Phenylephrine on Pupil Diameter and Accommodation in Rhesus Monkeys"; *Investigative Ophthalmology & Visual Science*, 2004, vol. 45, No. 1, pp. 215-221.
- Parel, Jean-Marie et al., "Intraocular Implants For The Surgical Correction of Presbyopia"; *In Ophthalmic Technologies X*, Proceedings of SPIE, vol. 3908, 2000, pp. 115-122.
- Patel, C.K. et al., "The Ageing Lens", *Association of Optometrists, City University, London*; undated, www.optometry.co.uk; pp. 27-31.
- Pau, Hans et al., "The increasing sclerosis of the human lens with age and its relevance to accommodation and presbyopia", *Graefe's Arch din Exp. Ophthalmol.*, (1991) vol. 229, pp. 294-296.
- Payne, Peter A. et al., "Ophthalmic Applications of Laser-Generated Ultrasound"; *SPIE*, vol. 3908, 2000, pp. 13-22.
- Peterson, Jennifer A. et al., "Intraocular Pressure Measurement in Cynomolgus Monkeys, Tono-Pen Versus Manometry", *Investigative Ophthalmology & Visual Science*, 1996, vol. 37, No. 6, pp. 1197-1199.
- Prokofeva, G. I et al., "Effects of Low-Intensity Infrared Laser Irradiation on the Eye, (An Experimental Study)", *Vestn. Ophthalmol.*, vol. 112, No. 1, 1996, pp. 31-32, with English Abstract, 5 pgs.

(56)

References Cited

OTHER PUBLICATIONS

- Puliafito, Carmen A., M.D. et al., "High-Speed Photography of Excimer Laser Ablation of the Cornea", *Arch Ophthalmol*, vol. 105, Sep. 1987, pp. 1255-1259.
- Qian, Wen et al., "3 Year Simvastatin Treatment and Lens Nuclear Back Scattering", *J Ophthalmol*, vol. 84, 2000, pp. 512-516.
- Qian, Wen et al., "Universal Opacity Standard for Scheimpflug Photography", *Ophthalmic Res*, 2000, vol. 32, pp. 292-298.
- Rafferty, Nancy et al., "Lens Wound Healing and Cataractogenesis in a Pigmented Eye", *Exp. Eye Res.* (1984) 38, 267-277.
- Riley, Michael V., et al., "The Effects of UV-B Irradiation on the Corneal Endothelium", *Eye Research Institute of Oakland University*, 1987, pp. 1021-1033.
- Ripken, T. et al., "FEM Simulation of the Human Lens Compared to Ex-Vivo Porcine Lens Cutting Pattern: A Possible Treatment of Presbyopia"; undated, 11 pgs.
- Ripken T. et al., "First in-vivo studies of Presbyopia treatment with ultrashort laser pulses", *Proc. SPIE 5142*, vol. 137, 2003, p pgs.
- Ripken, T. et al., "Fs-laser Induced Elasticity Changes to Improve Presbyopic Lens Accommodation", undated, 10 pgs.
- Ripken T. et al., "Investigations for the correction of Presbyopia by fs-laser induced cuts", *Proc. SPIE 5314*, vol. 27, 2004, 9 pgs.
- Rockwell, B.A. et al., "Safe Use of Ultra-short Lasers"; *SPIE*, vol. 3616, 1999, pp. 32-39.
- Roesner, C.A.D. et al., "Light-Matter Interactions on the FEMTOSECOND Time Scale", *Department of Physics and Division of Engineering and Applied Sciences, Harvard University*; undated, pp. 1-27.
- Rol, Pascal et al., "An Optomechanical Eye Model for Observation of Lens Photoablation"; *SPIE*, 1997, vol. 2971, pp. 171-174.
- Sacks, Zachary S. et al., "Laser Spot Size as a Function of Tissue Depth and Laser Wavelength in Human Sclera", *SPIE*, 1998, vol. 3255, pp. 67-76.
- Sauteret, C. et al., "Laser designers eye petawatt power", *Laser Focus World*, Oct. 1990, pp. 85-92 with cover page.
- Scammon, Richard J. et al., "Simulations of Shock Waves and Cavitation Bubbles Produced in Water by Picosecond and Nanosecond Laser Pulses", *SPIE*, 1998, vol. 3254, pp. 264-275.
- Schacher, Ronald A. MD, PhD., et al., "A Revolutionary Variable Focus Lens", *Annals of Ophthalmology*, vol. 28, No. 1, Jan./Feb. 1996, pp. 11-18.
- Schachar, Ronald A., M.D., "Cause and Treatment of Presbyopia With a Method for Increasing the Amplitude of Accommodation", *Annals of Ophthalmology*, 1992; 24:445-452.
- Schachar, Ronald A., M.D. et al., "Experimental Destruction of Cataractous Lenses by Laser", *Ophthalmic Surgery, Surgical Forum*, pp. 506-509.
- Schachar, Ronald A., M.D. et al., "Experimental Support for Schachar's Hypothesis of Accommodation", *Ann Ophthalmol*, 1993; 25: 404-409.
- Schachar, Ronald A., MD, PhD, "Histology of the Ciliary Muscle-Zonular Connections", *Annals of Ophthalmology*, vol. 28, No. 2, Mar./Apr. 1996, 70-79.
- Schachar, Ronald A. MD et al., "Mechanism of Human Accommodation as Analyzed by Nonlinear Finite Element Analysis", *Ann Ophthalmol*; 2001; vol. 33, No. 2, pp. 103-112.
- Schachar, Ronald A., MD, PhD, "Pathophysiology of Accommodation and Presbyopia, Understanding the Clinical Implications", *J. Florida M.A.*, vol. 81, No. 4, Apr. 1994, pp. 268-271.
- Schaeffel, Frank, "Kappa And Hirschberg Ratio Measured With An Automated Video Gaze Tracker", *Optometry and Vision Science*, 2002, vol. 79, No. 5, pp. 329-334.
- Schaffer, Chris B. et al., "Dynamics of Femtosecond Laser-Induced Breakdown in Water From Femtoseconds to Microseconds", *Optics Express*, 2002, vol. 10, No. 3, pp. 196-203.
- Schaffer, Chris B. et al., "Morphology of Femtosecond Laser-Induced Structural Changes in Bulk Transparent Materials", *Applied Physics Letters*, vol. 84, No. 9, 2004, pp. 1441-1443.
- Shen, Nan, et al., "Ablation Of Cytoskeletal Filaments And Mitochondria In Live Cells Using A Femtosecond Laser Nanoscissor", *MCB*, 2005, vol. 2, No. 1, pp. 17-25.
- Shen, Nan; "Photodisruption in Biological Tissues Using Femtosecond Laser Pulses", *A Thesis Presented to the Department of Physics, Harvard University*, 2003, pp. 1-125.
- Shen, Nan, et al., "Photodisruption in Biological Tissues and Single Cells Using Femtosecond Laser Pulses", undated, 2 pgs.
- Shen, Nan, et al., "Surface and Bulk Photodisruption in Turbid Tissue Using Femtosecond Laser Pulses", *Department of Physics and Division of Engineering and Applied Sciences, Harvard University*, undated, pp. 1-24.
- Sher, Neal A., MD, "Hyperopic Refractive Surgery", *Current Opinion In Ophthalmology*, 2001, vol. 12, pp. 304-308.
- Sivak, Jacob G., "Through The Lens Clearly: Phylogeny And Development, The Proctor Lecture", *Ophthalmology & Visual Science*, 2004, vol. 45, No. 3, pp. 740-747.
- Sliney, D. H et al., "Medical Lasers and Their Safe Use", *Springer Verlag*, New York, 1993, pp. 42-50.
- Slingsby, Christine, "Lens Crystallin Crystal Structures", undated article. 3 pgs.
- Soderberg, Per G., et al., "Angular Dependence Of The Intensity Of Back Scattered Light From Human Lenses With Nuclear Cataract, Implications For Measurement", *SPIE*, 2000, vol. 3908, pp. 34-37.
- Söderberg, Per G., et al., "External Standard for Measurements with The Scheimpflug Slitlamp Microscope", *SPIE*, 1997, vol. 2971, pp. 8-13.
- Soileau, M. J. et al., "Temporal Dependence of laser-Induced Breakdown in NaCl and SiO₂", prepared for Dept. of Physics, North Texas State University, publication date unknown, 19 pgs.
- Solomon, Ira Seth, M.D., "Aqueous Humor Dynamics", undated, 17 pgs.
- Spector, Abraham, "Aging of the Lens and Cataract Formation", *Aging and Human Visual Function*, pp. 27-43.
- Srinivasan, R., "Ablation of Polymers and Biological Tissue by Ultraviolet Lasers", Oct. 1986, pp. 932-935.
- Srinivasan R. et al., "Excimer Laser Surgery of the Cornea", *American Journal of Ophthalmology*, vol. 96, 1993, pp. 710-715.
- Stitzel, Joel D., et al., "A Nonlinear Finite Element Model of the Eye With Experimental Validation for the Prediction of Globe Rupture", *Stapp Car Crash Journal*, 2002, vol. 45, 24 pgs.
- Stitzel, Joel D., et al., "Blunt Trauma Of The Aging Eye", *Arch Ophthalmol*, 2005, vol. 123, pp. 789-794.
- Strauss, Moshe, et al., "Two-Dimensional Rayleigh Model of Vapor Bubble Evolution", *SPIE*, 1999, vol. 3601, pp. 212-224.
- Strenk, Susan A., et al, "Age-Related Changes in Human Ciliary Muscle and Lens: A Magnetic Resonance Imaging Study", *Investigative Ophthalmology & Visual Science*, 1999, vol. 40, No. 6, pp. 1162-1169.
- Strenk, Susan A. et al., "Magnetic Resonance Imaging Study of the Effects of Age and Accommodation on the Human Lens Cross-Sectional Area", *IOVS*, 2004, Vol. 45, No. 2, pp. 539-545.
- Strenk, Susan A., et al, "The Mechanism of Presbyopia", *Progress in Retinal and Eye Research*, 2004 vol. 11, pp. 1-15.
- Stuart, B. C. et al., "Laser-Induced Damage in Dielectrics with Nanosecond to Subpicosecond Pulses", *Physical Review Letters*, vol. 74, No. 12, Mar. 20, 1995, pp. 2248-2251.
- Sweeney, Matthew H.J., et al., "Movement of Cysteine in Intact Monkey Lenses: The Major Site of Entry is the Germinative Region", *Experimental Eye Research*, 2003, vol. 77, pp. 245-251.
- Swegmark, Gunnar, "Studies With Impedance Cyclography on Human Ocular Accommodation At Different Ages", *ACTA Ophthalmologica*, vol. 47, 1969, pp. 1186-1206.
- Taboada, J., et al., "Optically Coupled Technique for Photorefractive Surgery of the Cornea", *Optics Letters*, vol. 15, No. 9, May 1, 1990, pp. 458-460.
- Taboada, J. et al., "Response of the Corneal Epithelium to KrF Excimer Laser Pulses", *Health Physics*, vol. 30, 1981, pp. 677-683.
- Tahi, Hassan, et al., "Restoring Accommodation: Surgical Technique and Preliminary Evaluation in Rabbits", *SPIE*, 1999, vol. 3591, pp. 267-269.

(56)

References Cited

OTHER PUBLICATIONS

- Tamm, Svenja, et al., "Age-Related Changes of the Human Ciliary Muscle. A Quantitative Morphometric Study", *Mechanisms of Aging and Development*, vol. 62, 1992, pp. 209-221.
- Tang, Daxin; "Influence of Age, Diabetes, and Cataract on Calcium, Lipid-Calcium, and Protein-Calcium Relationships in Human Lenses", *Investigative Ophthalmology & Visual Science*, 2003, vol. 44, No. 5, pp. 2059-2066.
- Taylor, Virginia L. et al., "Morphology of the Normal Human Lens", *Investigative Ophthalmology & Visual Science*, Jun. 1996, vol. 37, No. 7, pp. 1396-1410.
- Topilow, Harvey W., M.D., "Vitreous Changes in Retinal Branch Vein Occlusion", *Arch Ophthalmol*, vol. 105, Sep. 1987.
- Trokel, Stephen L., M.D., et al., "Excimer Laser Surgery of the Cornea", *American Journal of Ophthalmology*, vol. 96, No. 6, Dec., 1983, 710-715.
- Tsai, Philbert S., "All-Optical, In-Situ Histology of Neuronal Tissue with Femtosecond Laser Pulses", *Imaging In Neuroscience and Development*, CSHL Press, undated, 12 pgs.
- Tsubota, Kazuo, "Application of Erbium: YAG Laser in Ocular Ablation", *Ophthalmologica*, 1990, 200:pp. 117-122.
- Van Alphen, G.W.H.M. et al., "Elasticity of Tissues Involved in Accommodation", *Vision Res.*, vol. 31, No. 7/8, 1991, pp. 1417-1438.
- Venugopalan, V. et al., "The Thermodynamic Response of Soft Biological Tissues to Ultraviolet Laser Irradiation", *Biophysical Journal*, vol. 60, Oct. 1995, pp. 1258-1271.
- Vilupuru, Abhiram S., "Optical and Biometric Relationships of the Isolated Pig Crystalline Lens", *Ophthal. Physiol. Opt.*, 2001, vol. 21, No. 4, pp. 296-311.
- Vilupuru, Abhiram S., "Spatially Variant Changes in Lens Power During Ocular Accommodation in a Rhesus Monkey Eye", *Journal of Vision*, 2004, vol. 4, pp. 299-309.
- Vogel, Alfred et al., "Factors Determining the Refractive Effects of Intrastromal Photorefractive Keratectomy with the Picosecond Laser", *J. Cataract Refract Surg.*, vol. 23, Nov. 1997, pp. 1301-1310.
- Vogel, Alfred et al., "Interaction of Laser-Produced Cavitation Bubbles With an Elastic Tissue Model", *SPIE*, 2001, vol. 4257, pp. 167-177.
- Vogel, Alfred et al., "Intraocular Photodisruption With Picosecond and Nanosecond laser Pulses: Tissue Effects in Cornea, Lens and Retina", *Investigative Ophthalmology & Visual Science*, Jun. 1994, No. 7, vol. 35, pp. 3032-3044.
- Vogel, Alfred et al., "Kinetics of Phase Transitions in Pulsed IR Laser Ablation of Biological Tissues", *SPIE*, 2003, vol. 4961, pp. 66-74.
- Vogel, Alfred et al., "Laser-Induced Breakdown In The Eye At Pulse Durations From 80 ns to 100 fs", *SPIE*, 1998, vol. 3255, pp. 34-49.
- Vogel, Alfred et al., "Numerical Simulation Of Optical Breakdown For Cellular Surgery At Nanosecond To Femtosecond Time Scales", *SPIE*, 2001, vol. 4433, pp. 70-80.
- Vrensen, G. F. J. M., "Aging of the human eye lens—A morphological point of view", *Comp. Biochem. Physiol.*, vol. 111A, 1995. pp. 519-53.
- Waring III, George O., M.D., "Presbyopia and Accommodative Intraocular Lenses—the Next Frontier in Refractive Surgery?", *Refractive & Corneal Surgery*, vol. 8, Nov./Dec. 1992, pp. 421-423.
- Weale, Robert D., SC., "Presbyopia Toward the End of the 20th Century", *Survey of Ophthalmology*, vol. 34, No. 1, Jul.-Aug. 1989, pp. 15-29.
- Werblin, Theodore P., M.D., "Should We Consider Clear Lens Extraction for Routine Refractive Surgery?", *Refractive & Corneal Surgery*, vol. 8, Nov./Dec. 1992, pp. 480-481.
- Werner, Liliana, MD, et al., "Capsular Bag Opacification After Experimental Implantation of a New Accommodating Intraocular Lens in Rabbit Eyes", *J Cataract Refract Surg.*, 2004, vol. 30, pp. 1114-1123.
- Werner, Liliana, MD. et al., "Posterior Capsule Opacification in Rabbit Eyes Implanted With 1-Piece and 3-Piece Hydrophobic Acrylic Intraocular Lenses", *J Cataract Refract Surg*, 2005, vol. 31, pp. 805-811.
- Wilks, S. C. et al., "Absorption of ultra-Intense Laser Pulses", *Physical Review Letters*, vol. 69, No. 9, Aug. 31, 1992, pp. 1383-1386.
- Wyatt, Harry J., "Application of a Simple Mechanical Model of Accommodation to the Aging Eye", *Eye Res.*, vol. 33, No. 5/6, 1993, pp. 731-738.
- Ziebarth, Noel, et al; "Non-contact Optical Measurement of Lens Capsule Thickness During Simulated Accommodation", *SPIE*, 2005, vol. 5688, pp. 19-25.
- Zuclich, Joseph a. et al., "A comparison of laser-induced retinal damage from infrared wavelengths to that from visible wavelengths", *Lasers and Light*, vol. 8, No. 1, 1997, pp. 1529.
- Zuclich, Joseph A. et al., "In Situ Measurements of Lens Fluorescence and its Interference With Visual Function", *Investigative Ophthalmology & Visual Science*, vol. 33, No. 2, 1993, pp. 410-415.
- Zuclich, Joseph, "In Vivo Measurements of Optical Properties of the Ocular Lens", Reprinted from Proceedings of Ultraviolet Radiation Hazards, Jan. 26-27, 1994, *SPIE—The International Society for Optical Engineering*, Vo. 21348 Ultraviolet Radiation Hazards, 1994, pp. 99-112.
- Zuclich, J.A., et al., "Ocular Effects of Penetrating IR Laser Wavelengths", Reprinted from Proceedings of Laser-Tissue Interaction VI, Feb. 6-9, 1995, *SPIE—The International Society for Optical Engineering*, vol. 2391, 1995, pp. 111-125.
- Zuclich, Joseph A., et al., "Rapid Noninvasive Optical Characterization of the Human Lens", *Lasers in the Life Sciences*, 6(1), 1994, pp. 39-53.
- Zuclich, Joseph A., "Research on the Ocular Effects of Laser Radiation", Published by *Technology Incorporated: Life Sciences Division*, publication date unknown, 59 pgs.
- Zuclich, Joseph A., "Ultraviolet-Induced Photochemical Damage in Ocular Tissues", *Health Physics*, vol. 56, No. 5, May 1989, pp. 671-681.
- Zuclich, Joseph A., "Workshop on Long-Term Visual Health Risks of Optical Radiation—Thermal Cataracts Induced by Uv Laser Radiation", *Workshop Report, Cataract Working Group*, publisher unknown, publication date unknown, 13 pgs.
- Agrahari, S. et al., "The Potential of Photodisruption Laser Treatment of the Crystalline Lens to Rupture the Lens Capsule", *ARVO Abstract No. 07-A-6800*, 2006, 1 pg.
- Faraggi, E. et al., "Stress confinement, shock wave formation and laser induced damage", Conference 5695: Optical Interactions with Tissue and Cells XVI, *Photonics West*, undated, 1 pg.
- Fisher, R F, "The ciliary body in accommodation", *Trans Ophthalmol. Soc. UK*, 1989, vol. 105, 1 pg.
- Fisher, RF. "The mechanics of accommodation in relation to presbyopia", *Eye*, 1988, vol. 2, 1 pg.
- Frey, R. W. et al., "Modification of Lens Mechanics of Human Cadaver and Porcine Lenses Using Photodisruption Laser to Change Lens Power and Increase Flexibility", *ARVO Abstract No. 07-A-06652*, 2006, 1 pg.
- Garner, LF et al., "Changes in equivalent and gradient refractive index of the crystalline lens with accommodation", *Optom Vis. Sci.*, 1997, vol. 74, 1 pg.
- Garner LF et al., "Changes in ocular dimensions and refraction with accommodation", *Ophthalmic Physiol. Opt.*, 1997, vol. 17, 1 pg.
- Gray, G. et al., "Constructions of a Computer Mesh Model of the Anatomical Human Crystalline Lens Fiber Ultrastructure", *ARVO Abstract*, 2006, 1 pg.
- Helsterkamp, A. et al., "Nanosurgery in live cells using ultrashort laser pulses", Conference 5695: Optical Interactions with Tissue and Cells XVI, *Photonics West*, undated, 1 pg.
- Kuszak, J.R., "Progressively More Complex Star Sutures Formed in Primate Lenses During Periods of Development, Growth and Aging Are Related to Accommodation", *Abstracts Online*, obtained from the Internet on Apr. 19, 2006 at: [http://www.abstractsonline.com/viewer/viewAbstractPrintFriendly.asp?CKey={C8FDF5D . . .](http://www.abstractsonline.com/viewer/viewAbstractPrintFriendly.asp?CKey={C8FDF5D...) Apr. 19, 2006, 1 page.
- Kuszak, J. R. et al., "Results From a Finite Element Model Analysis of the Accommodative Process Based on the Human Crystalline Lens Fiber Ultrastructure", *Arvo Abstract*, 2006, 1 pg.
- McBrien NA et al., "Experimental myopia in a diurnal mammal (*Sciurus carolinensis*) with no accommodative ability", *J Physiol.*, 1993, vol. 469, 1 pg.

(56)

References Cited

OTHER PUBLICATIONS

McCourt ME et al., "Refractive state, depth of focus and accommodation of the eye of the California ground squirrel (*Spermophilus beecheyi*)", *Vision Res.*, 1984, vol. 24, 1 pg.

Oberheide, U. et al., "Flexibility Increase of Human Donor Lenses After Femosecond Laser Treatment (fs-Lentotomy)", *ARVO Abstract No. 3833/B571*, 2007, 2 pgs.

Olmstead, T. et al., "The Use of an OffAxis Slit Laser Camera System for Determining Photodisruptive Laser Placement in Lenses", *ARVO Abstract No. 07-A-5967*, 2006, 1 pg.

Rafferty, NS et al., "Comparative study of actin filament patterns in lens epithelial cells, Are these determined by the mechanisms of lens accommodation?", *Curr Eye Res.*, 1989, vol. 8, 1 pg.

Roa, Ch. Mohan et al., "Level of Reduced Nucleotides and Lens Photodamage", *National Eye Institute*, undated, 1 pg.

Subramaniam, H. et al., "Finite Element Analysis of the Accommodative Process in the Whole Globe", *ARVO Abstract No. 07-A-6249*, 2006, 1 pg.

Van Alphen GW et al., "Elasticity of tissues involved in accommodation", *Vision Res.*, 1991, vol. 31, 1 pg.

Wang, B. et al., "In-vivo animal studies on intraocular nanosurgery with low-energy 80 MHZ near infrared femtosecond laser pulses", Conference 5695: Optical Interactions with Tissue and Cells XVI, *Photonics West*, undated, 1 pg.

Yeilding, R. H. et al., "Lens Culture System for Long Term Study of Porcine Lenses Pre and Post Laser Photodisruption Treatment", *ARVO Abstract No. 01-A-6495*, 2006, 1 pg.

Zepkin, N. et al., "Measurement of Temperature Rise in Porcine Crystalline Lenses from a Photodisruption Laser", *ARVO Abstract No. 07-A-6709*, 2006, 1 pg.

Zoltoski, R. K. et al., "Reverse Engineering of Human Lenses", *ARVO Abstract No. 2018/B159*, 2007, 2 pgs.

AVRO, "Statement for the Use of Animals in Ophthalmic and Visual Research", *The Association for Research in Vision and Ophthalmology*, copyright © 2002, obtained from the Internet on Jan. 15, 2005 at: <http://www.avro.org/AboutAvro/animalst.asp>, 3 pgs.

Gattass, Rafael et al., "Femtosecond laser micromachining Applications in Technology and Biology", *Photonics West conference Jan. 2005*, 78 pgs.

Hermans, E. et al., "Estimating the External Force Acting on the Human Eye Lens During Accommodation Using Finite Elements Modeling", presentation on Accommodation & Presbyopia, May 2005, 1 pg.

Kuszak et al., "Light, scanning and electron micrographs have lead to the following interpretations of secondary fiber formation", 2004, 16 pgs.

Lubatschowski, H. et al., "Treatment of Presbyopia by Cutting the Crystalline Lens: A Comparison of FEM Simulation and Ex vivo Studies", *Lazer Zentrum Hannover e. V.*, Publication date unknown, 22 pgs.

Mazur, Eric, "An Introduction to Femtosecond Laser Science", *Photonics West conference Jan. 2005*, 291 pgs.

Nebel, Achim et al., "Fast Micromachining using Picosecond Lasers", *Photonics West conference Jan. 2005*, 37 pgs.

OSN SuperSite, "Increase in lens stiffness with age may cause presbyopia, study suggests", 2005, 1 pg.

"Presbyopia—preconditions", *Laser Zentrum Hannover*, undated, 11 pgs.

"Principles of Ultrafast Laser Surgery Femtosecond Laser-Tissue Interaction", copyright © Center for Ultrafast Optical Sciences, Un. of Michigan, undated, 3 pgs.

Roundy, Carlos—"Propagation factor qualifies leaser bean performance", *Laser World Focus*, undated, 3 pgs.

Shen, J. et al. "Measurement of the Lens Capsule Contraction Force in the Radial Direction", presentation on Accommodation & Presbyopia, May 2005, 1 pg.

Figure 4.2—Optical constants for a "standard eye", publication unknown, undated, 1 pg.

Picture of an eye obtained from the Internet on Mar. 28, 2005 at: <http://www.opt.uh.edu/research/aglasser/aao/gonioani.gif>, 1 pg.

Pictures of eyes, date and publisher unknown, 5 pgs.

Loesel paper graphs, date and publisher unknown, 2 pgs.

* cited by examiner

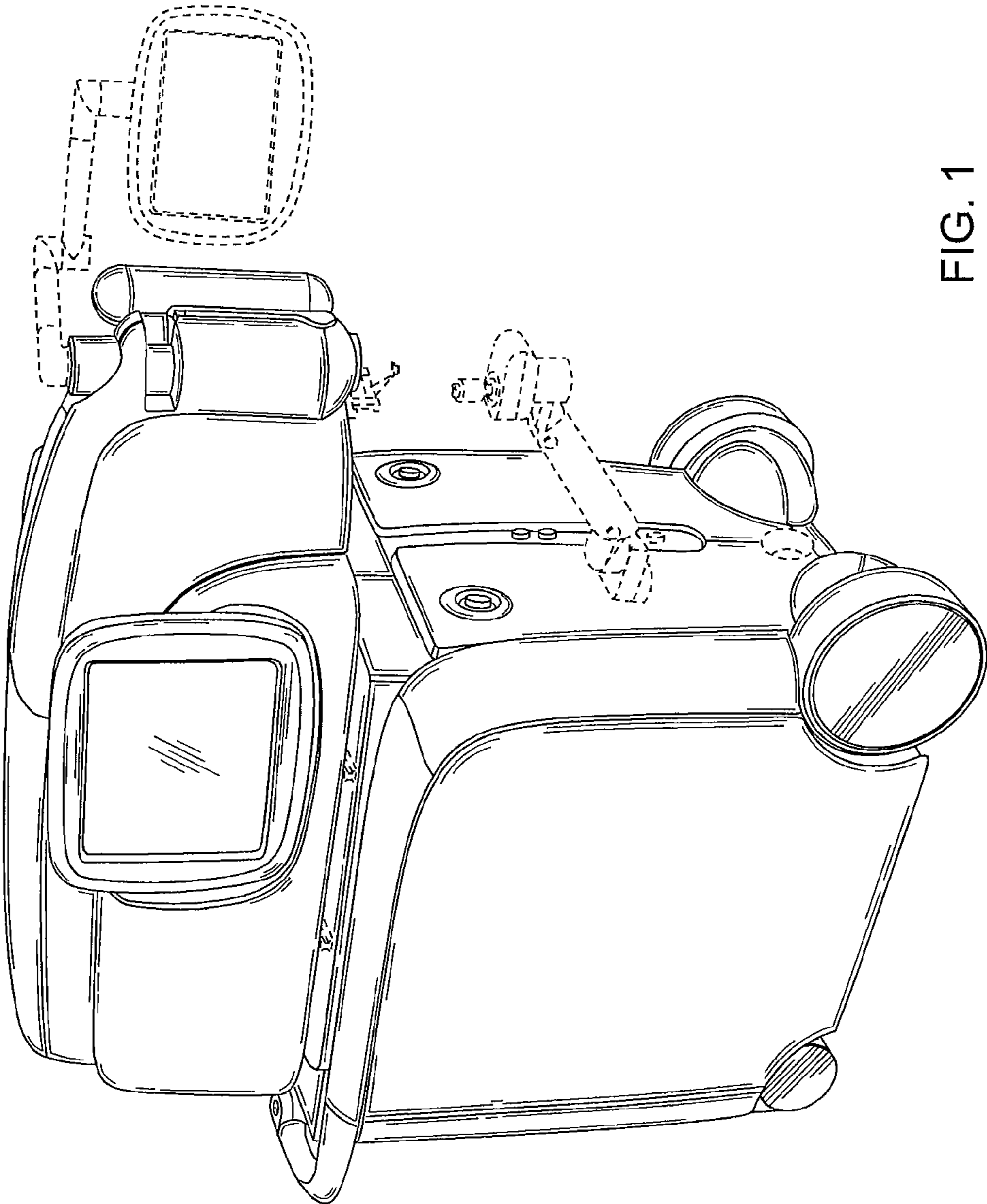

FIG. 1

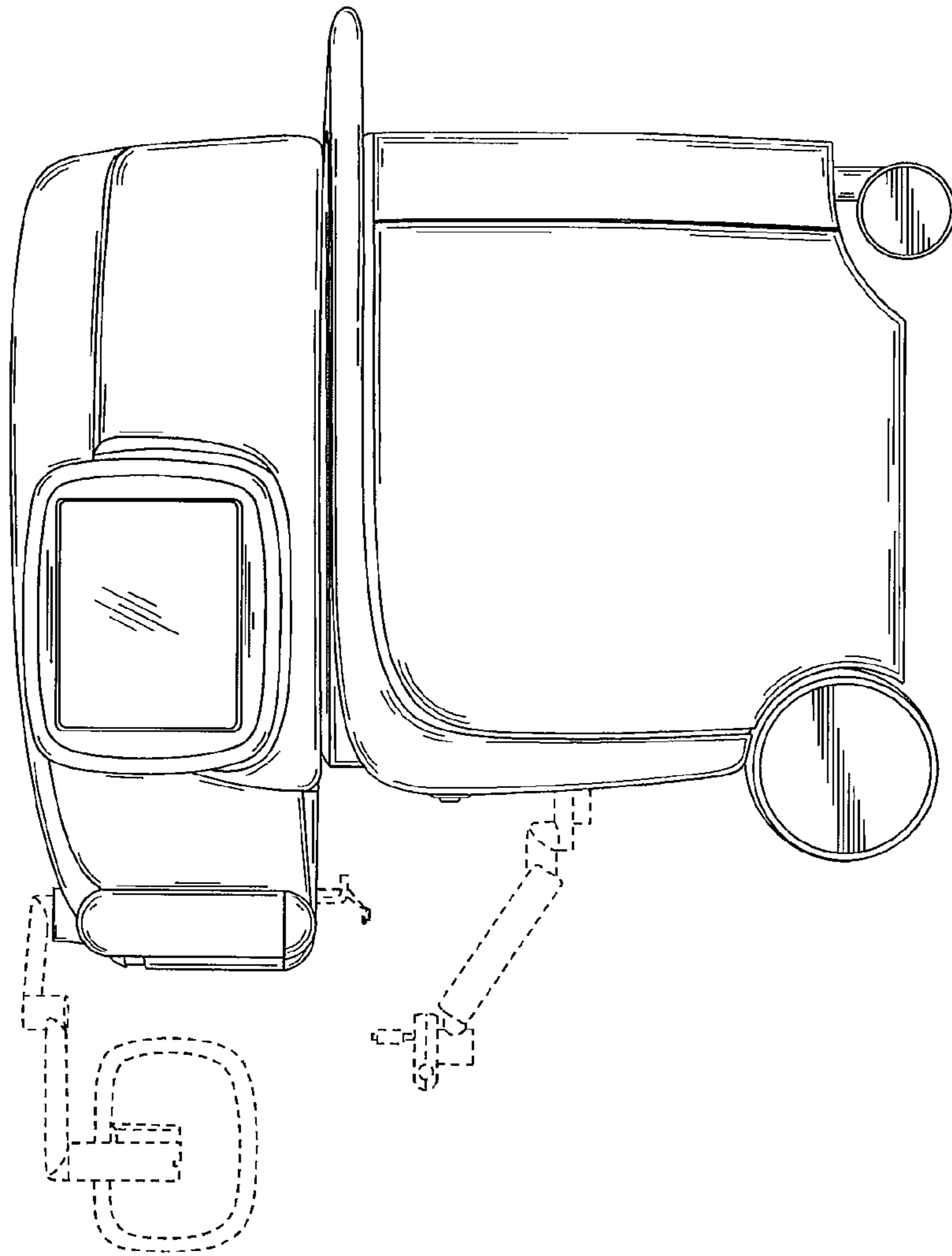

FIG. 2

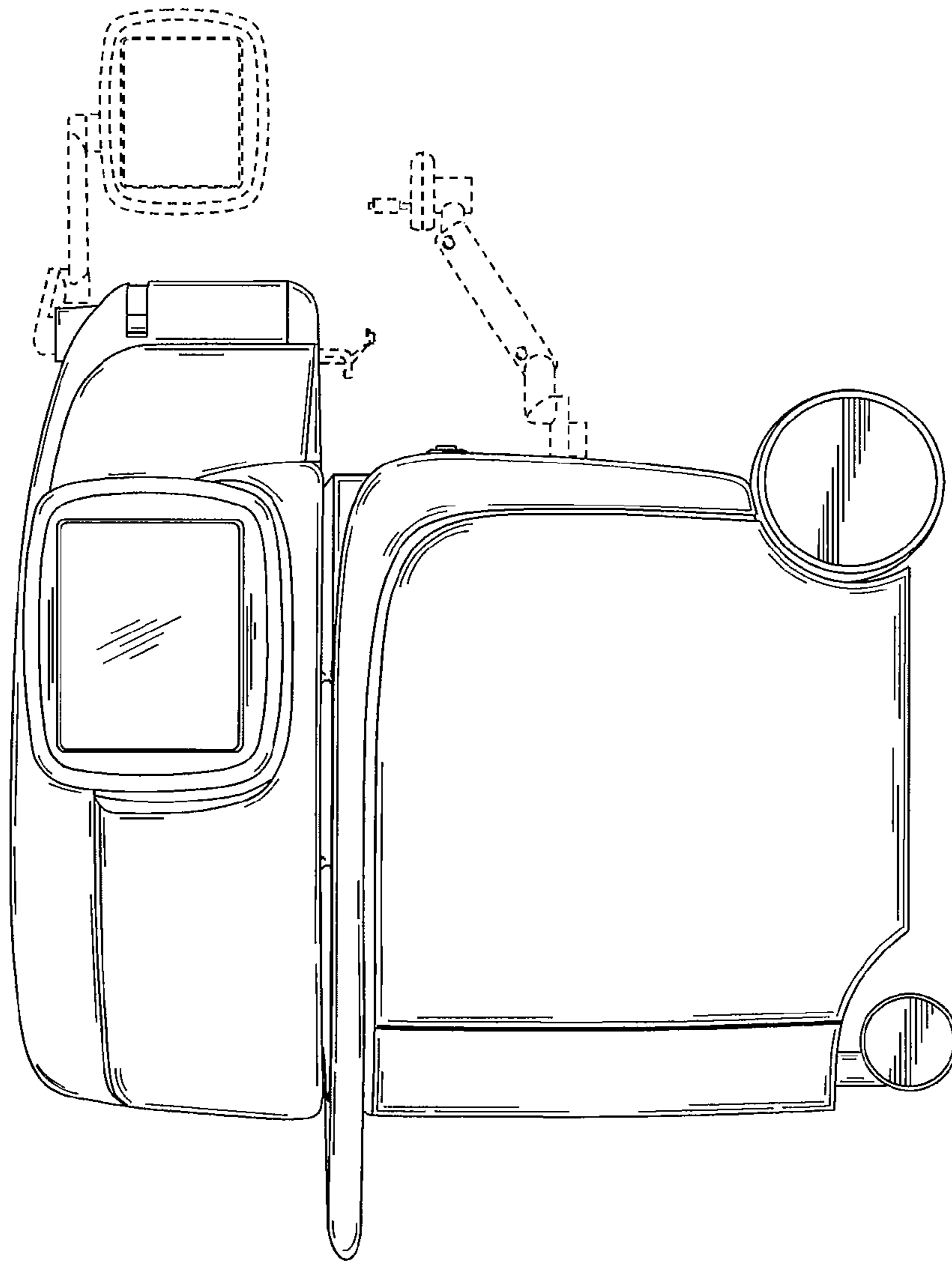

FIG. 3

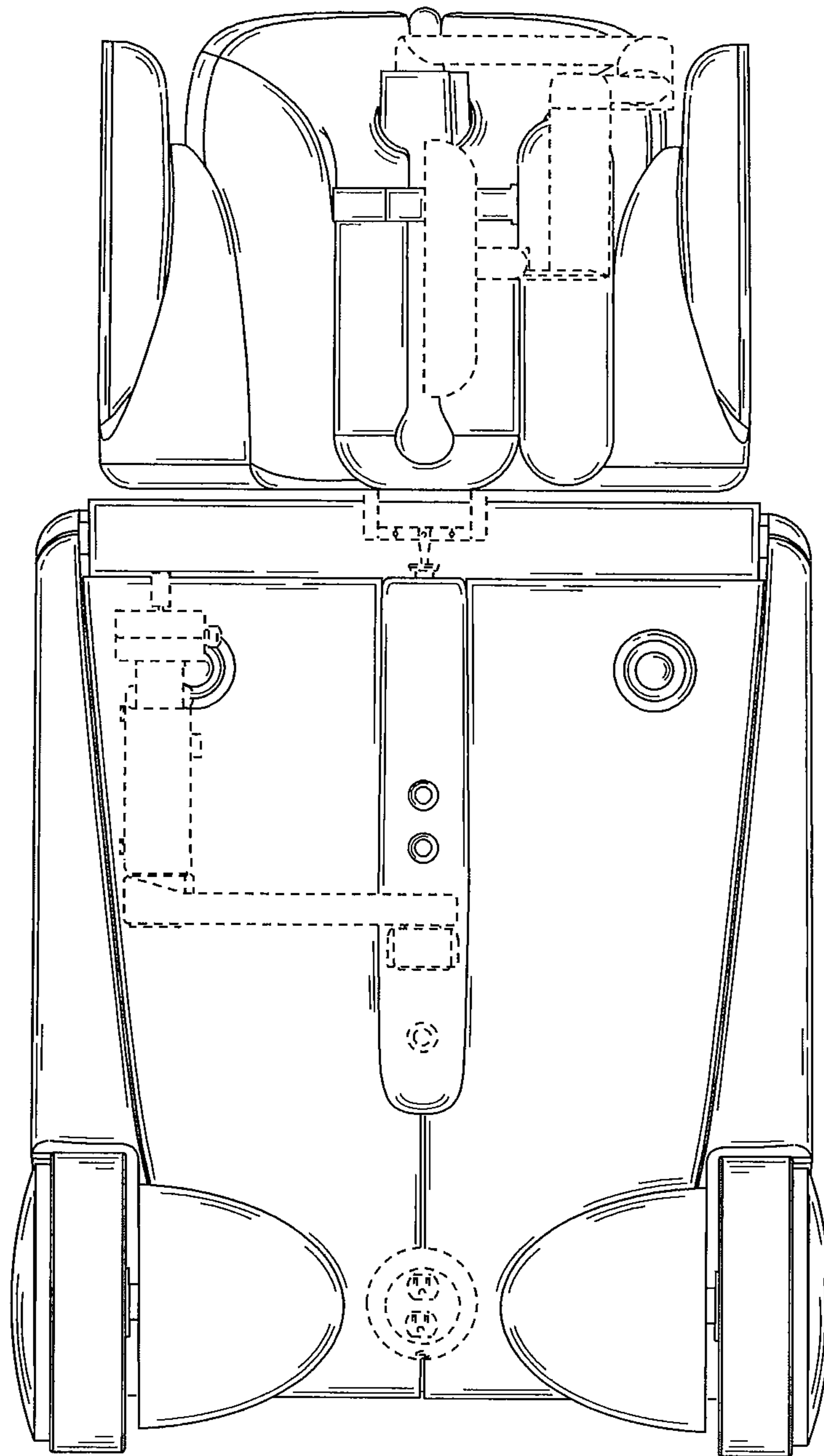

FIG. 4

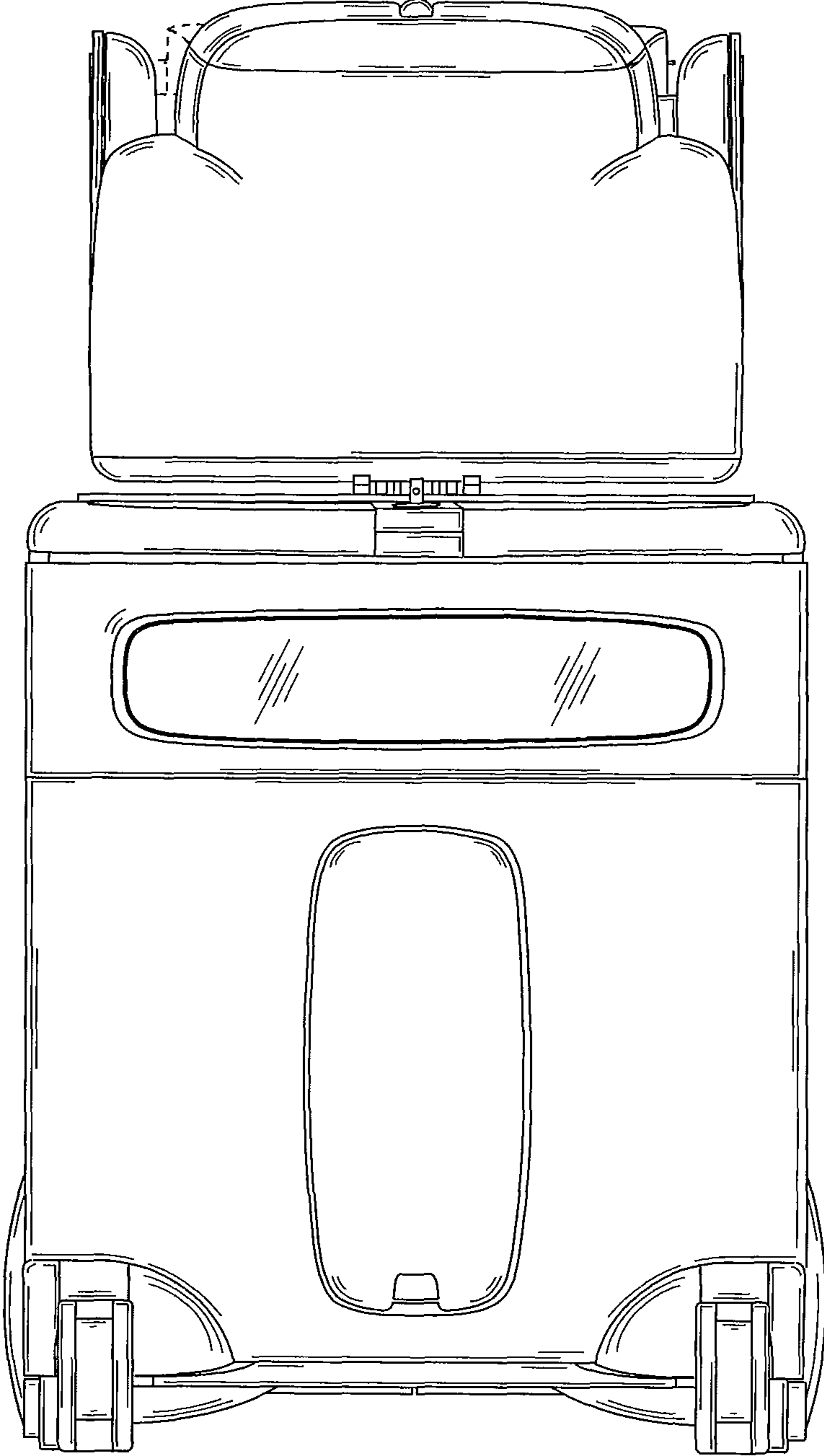

FIG. 5

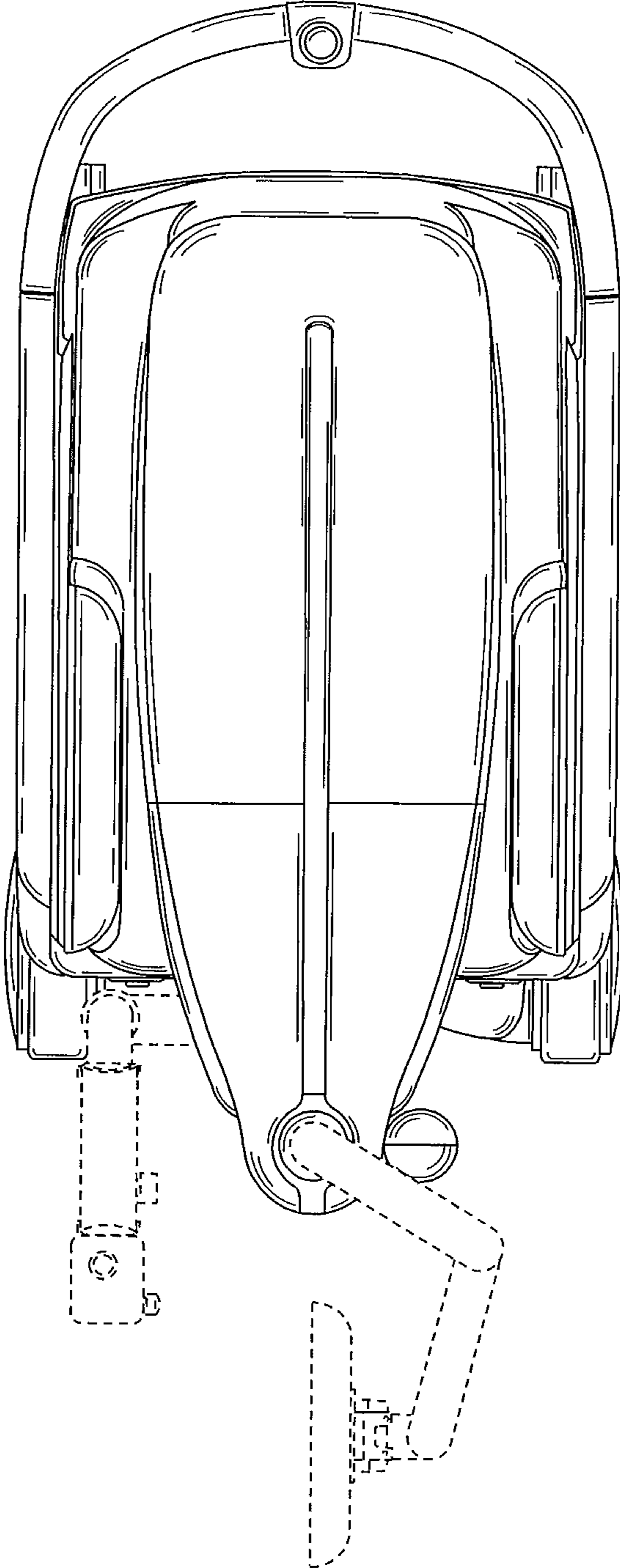

FIG. 6

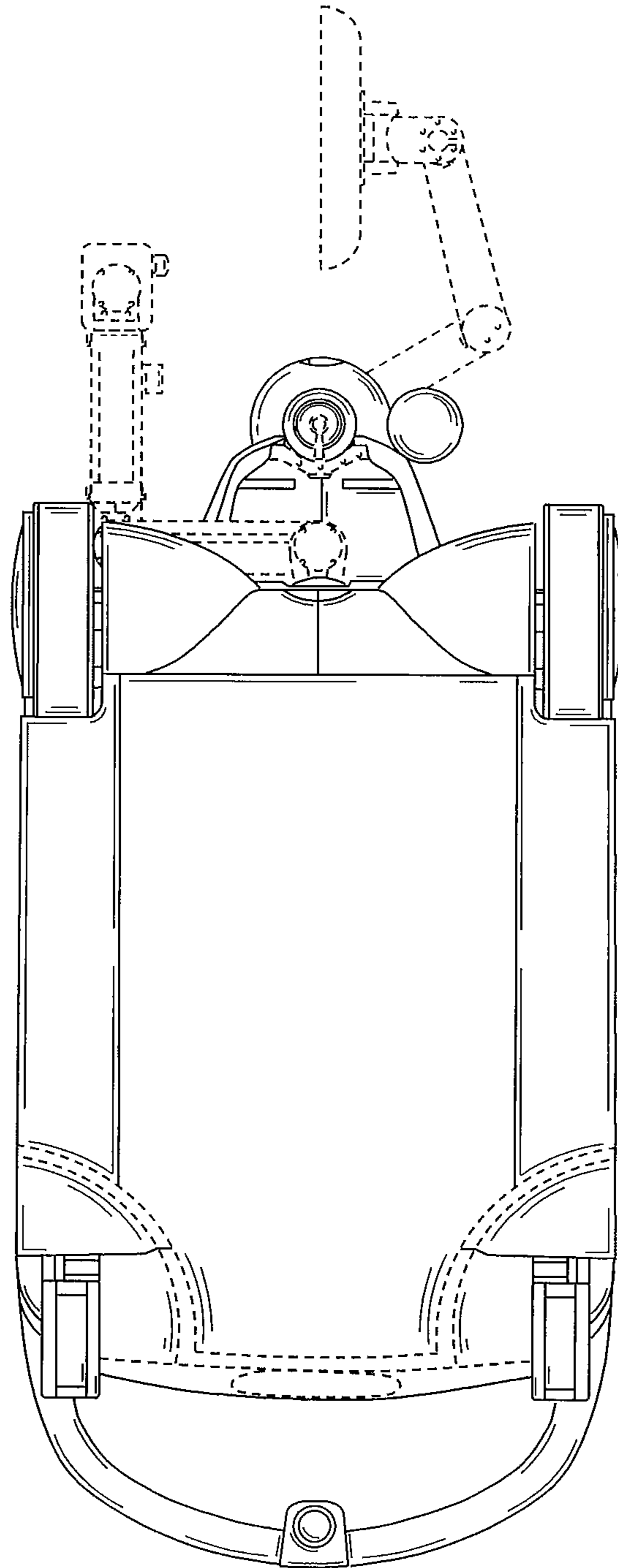

FIG. 7

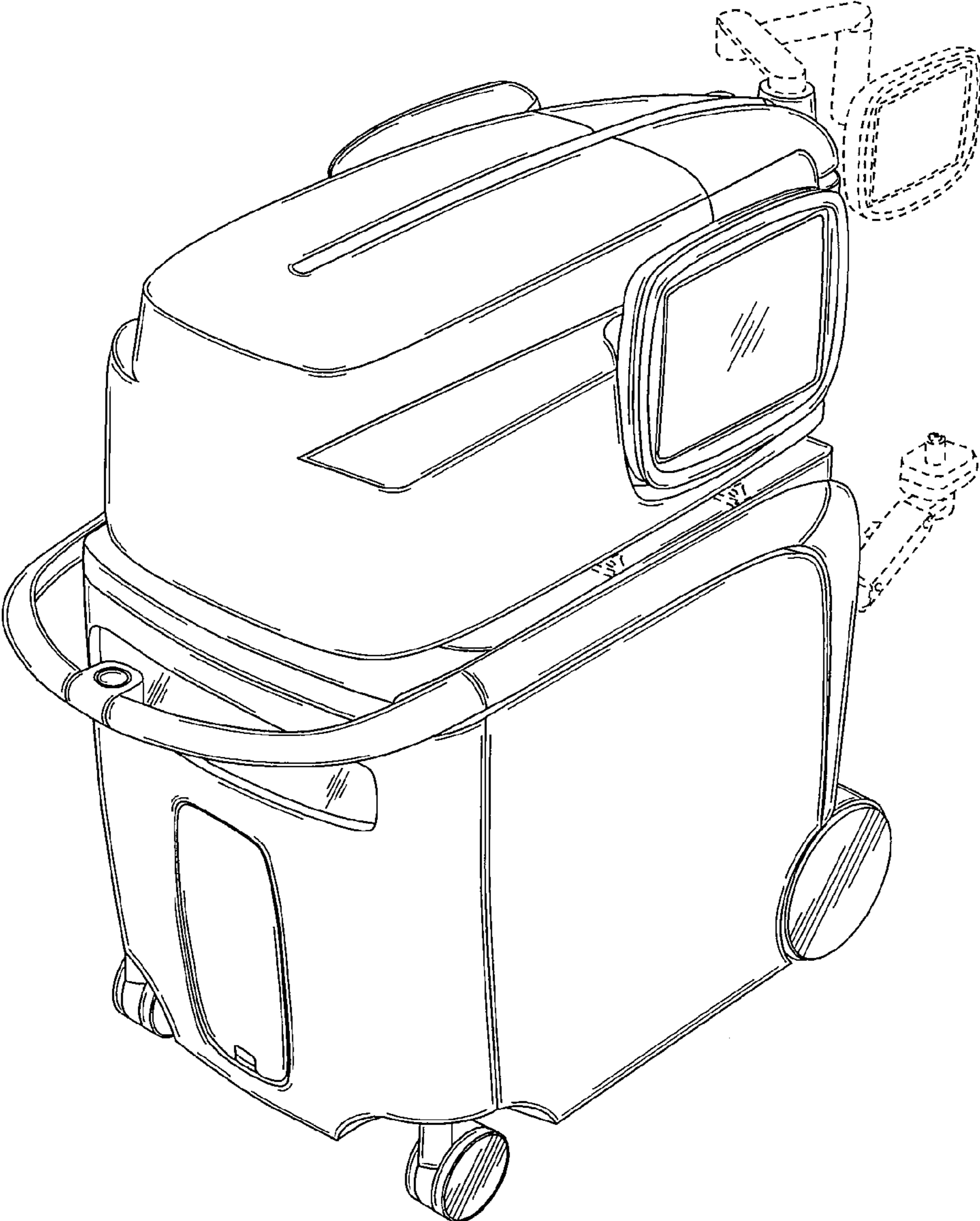

FIG. 8

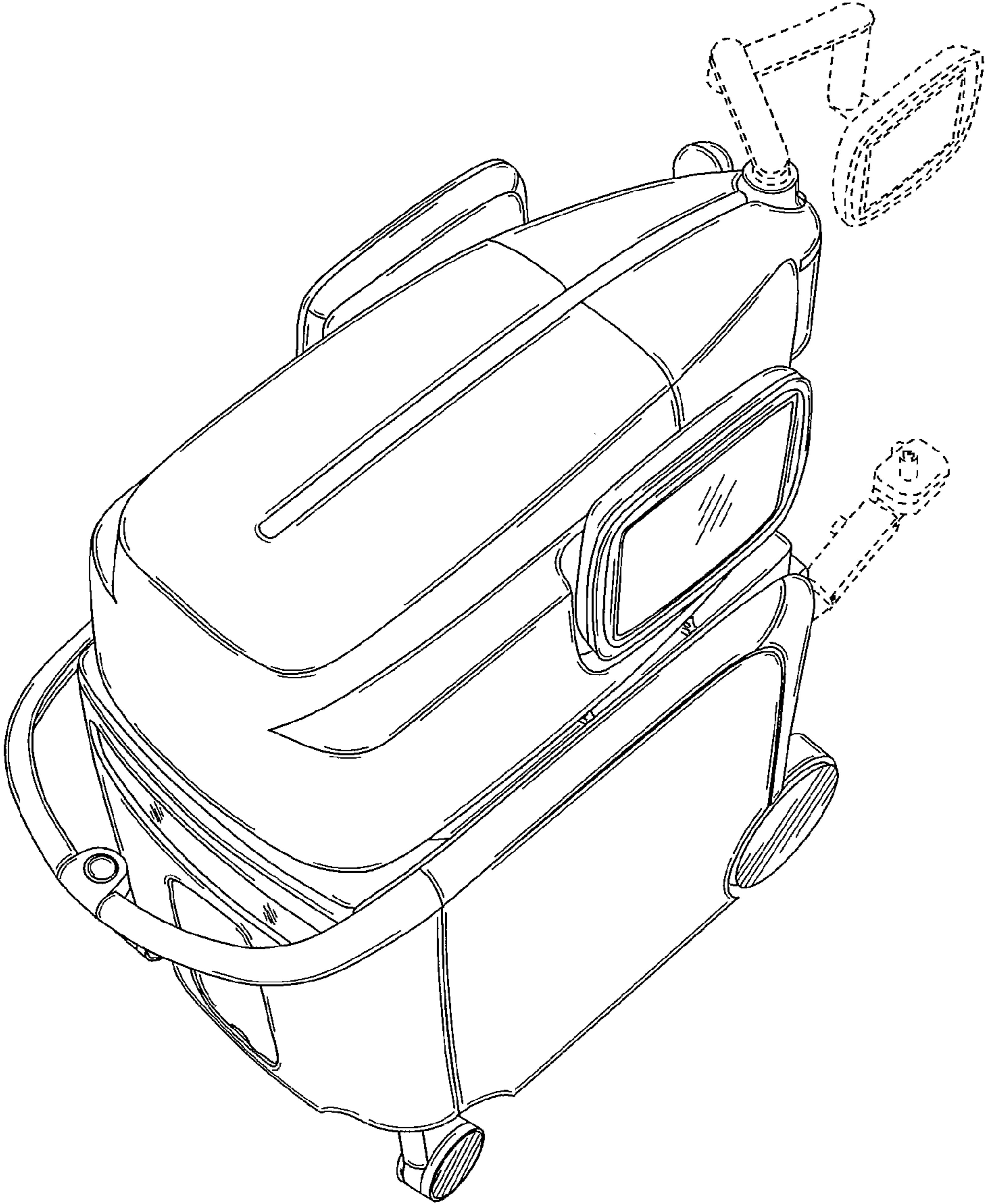

FIG. 9