

US00D694669S

(12) **United States Design Patent**
Schwenk

(10) **Patent No.:** **US D694,669 S**

(45) **Date of Patent:** **** Dec. 3, 2013**

(54) **KART HAVING DRIVE UNIT AND STEERING UNIT**

(76) Inventor: **Peter Schwenk**, Neuleiningen (DE)

(**) Term: **14 Years**

(21) Appl. No.: **29/415,539**

(22) Filed: **Mar. 12, 2012**

(30) **Foreign Application Priority Data**

Sep. 14, 2011 (EM) 001 917 501

(51) **LOC (9) Cl.** **12-02**

(52) **U.S. Cl.**
USPC **D12/16; D12/1**

(58) **Field of Classification Search**
USPC D34/15, 12; 180/233, 908, 55;
280/DIG. 5, 183, 184, 185, 186, 28,
280/37.7, 287; D12/107, 1, 16
See application file for complete search history.

(56) **References Cited**

U.S. PATENT DOCUMENTS

5,312,126 A * 5/1994 Shortt et al. 280/287
7,537,076 B2 * 5/2009 Falkner 180/208
D657,523 S * 4/2012 Gong D34/15
2011/0215542 A1 * 9/2011 Wang 280/35
2012/0205170 A1 * 8/2012 Adams 180/55

* cited by examiner

Primary Examiner — T. Chase Nelson

Assistant Examiner — Ania Aman

(74) *Attorney, Agent, or Firm* — Muirhead and Saturnelli, LLC

(57) **CLAIM**

The ornamental design for a kart having a drive unit and a steering unit, as shown and described.

DESCRIPTION

FIG. 1 is a front perspective view showing the new design for a kart having a drive unit and a steering unit; FIG. 2 is a rear perspective view thereof; FIG. 3 is a front elevational view thereof; FIG. 4 is a rear elevational view thereof; FIG. 5 is a side elevational view thereof; FIG. 6 is a top plan view thereof; FIG. 7 is a front elevational view of the drive unit for the kart, the drive unit being shown separately for ease of illustration only; FIG. 8 is a rear elevational view thereof; FIG. 9 is a side elevational view thereof; FIG. 10 is a top plan view thereof; FIG. 11 is a front elevational view of the steering unit for the kart in a use position, the steering unit being shown separately for ease of illustration only; FIG. 12 is a rear elevational view thereof; FIG. 13 is a side elevational view thereof; FIG. 14 is a top plan view thereof; FIG. 15 is a side elevational view of the steering unit for the kart in a storage position, the steering unit being shown separately for ease of illustration only; and, FIG. 16 is a top plan view thereof. The broken lines shown in the drawings illustrate portions of environmental structure and form no part of the claimed design.

1 Claim, 16 Drawing Sheets





FIG. 1

FIG. 2

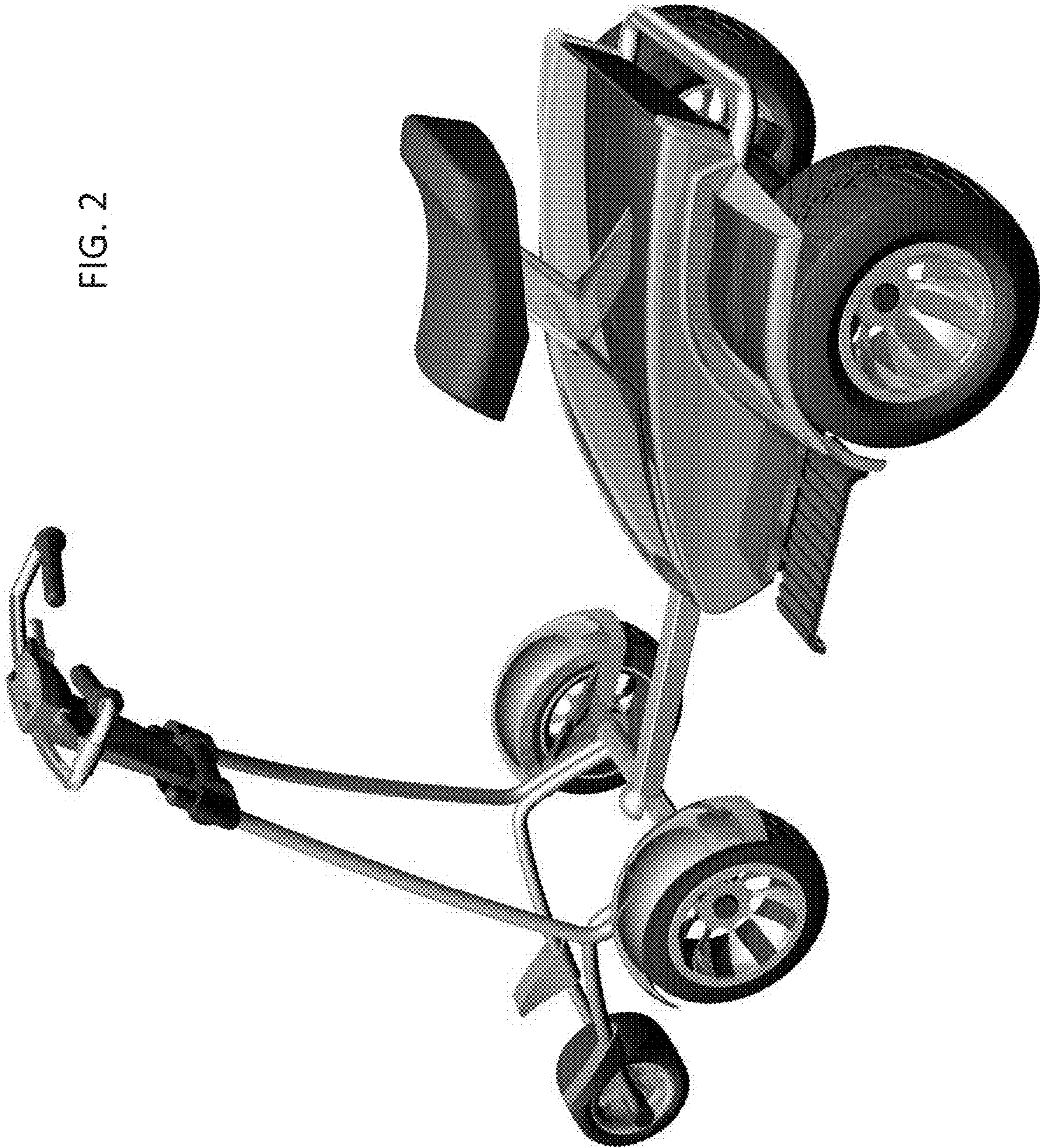

FIG. 3

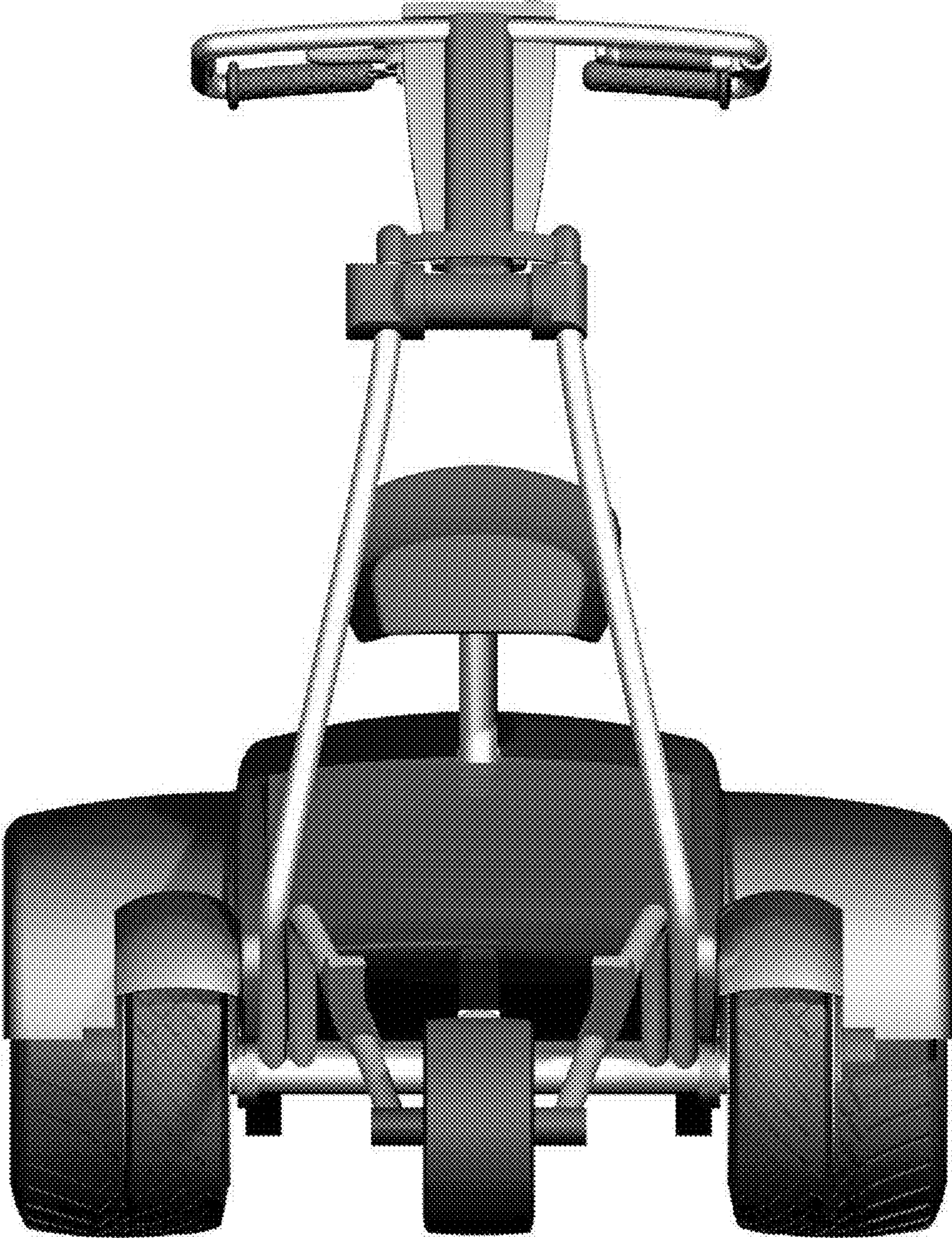

FIG. 4

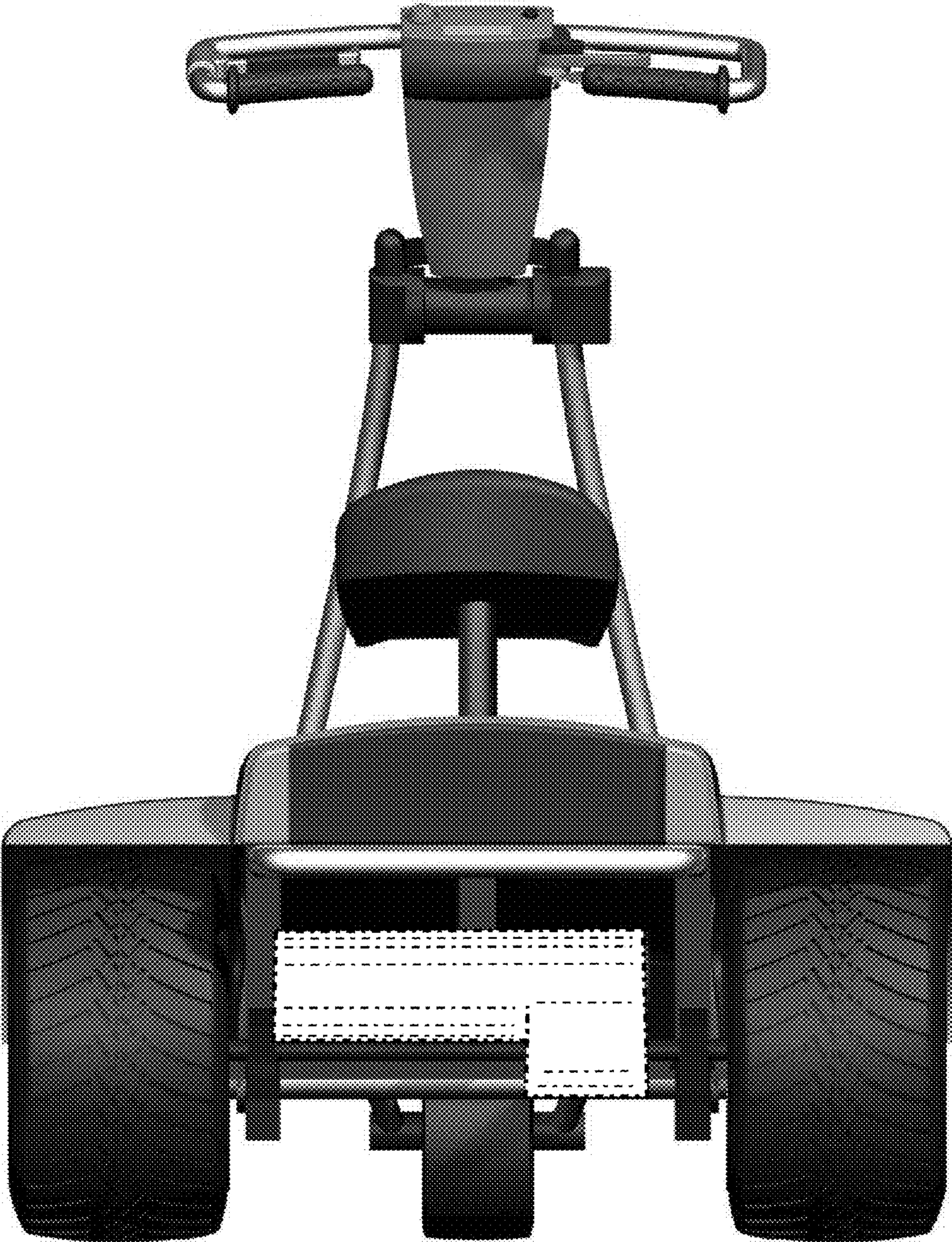

FIG. 5



FIG. 6

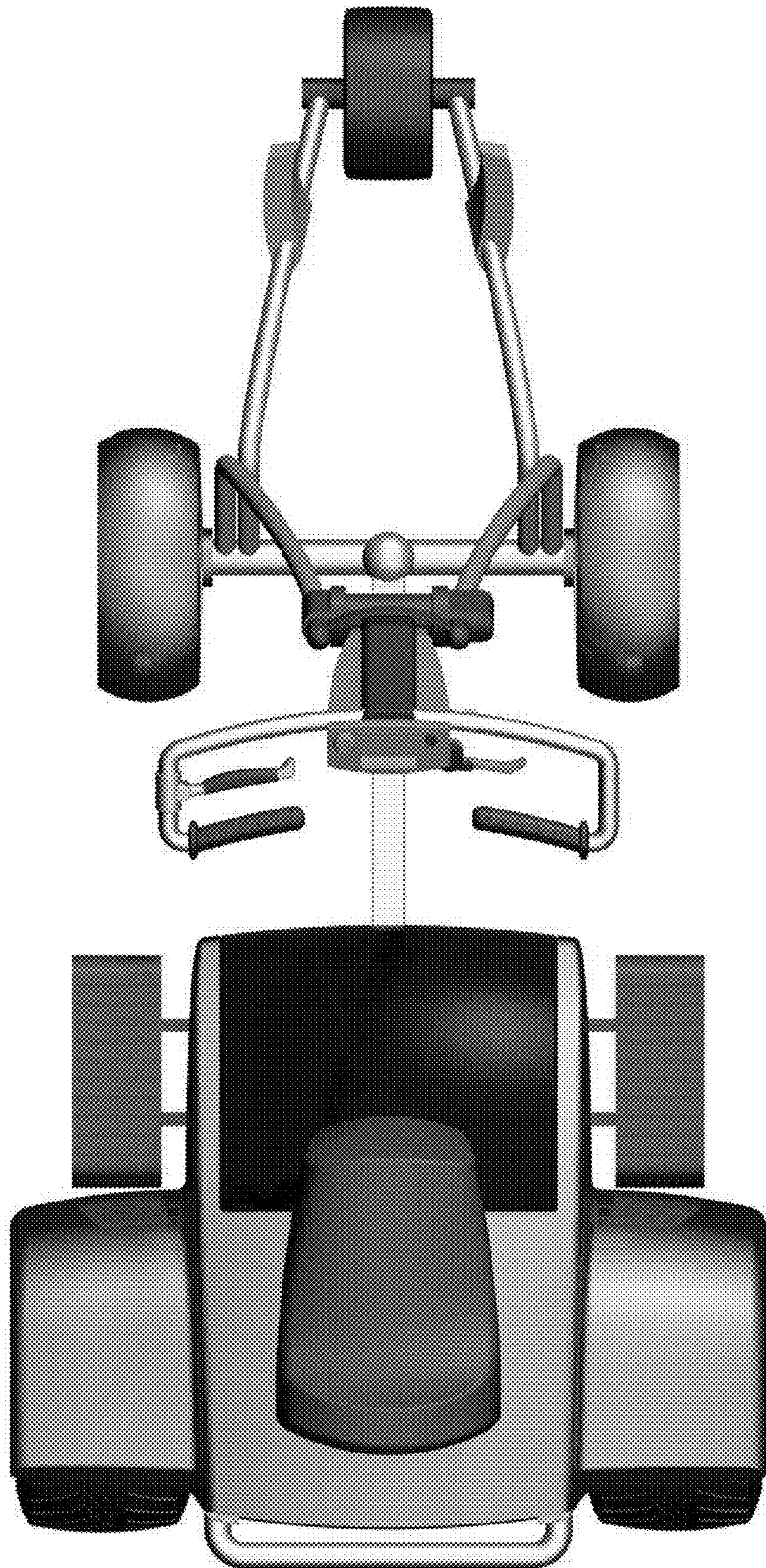
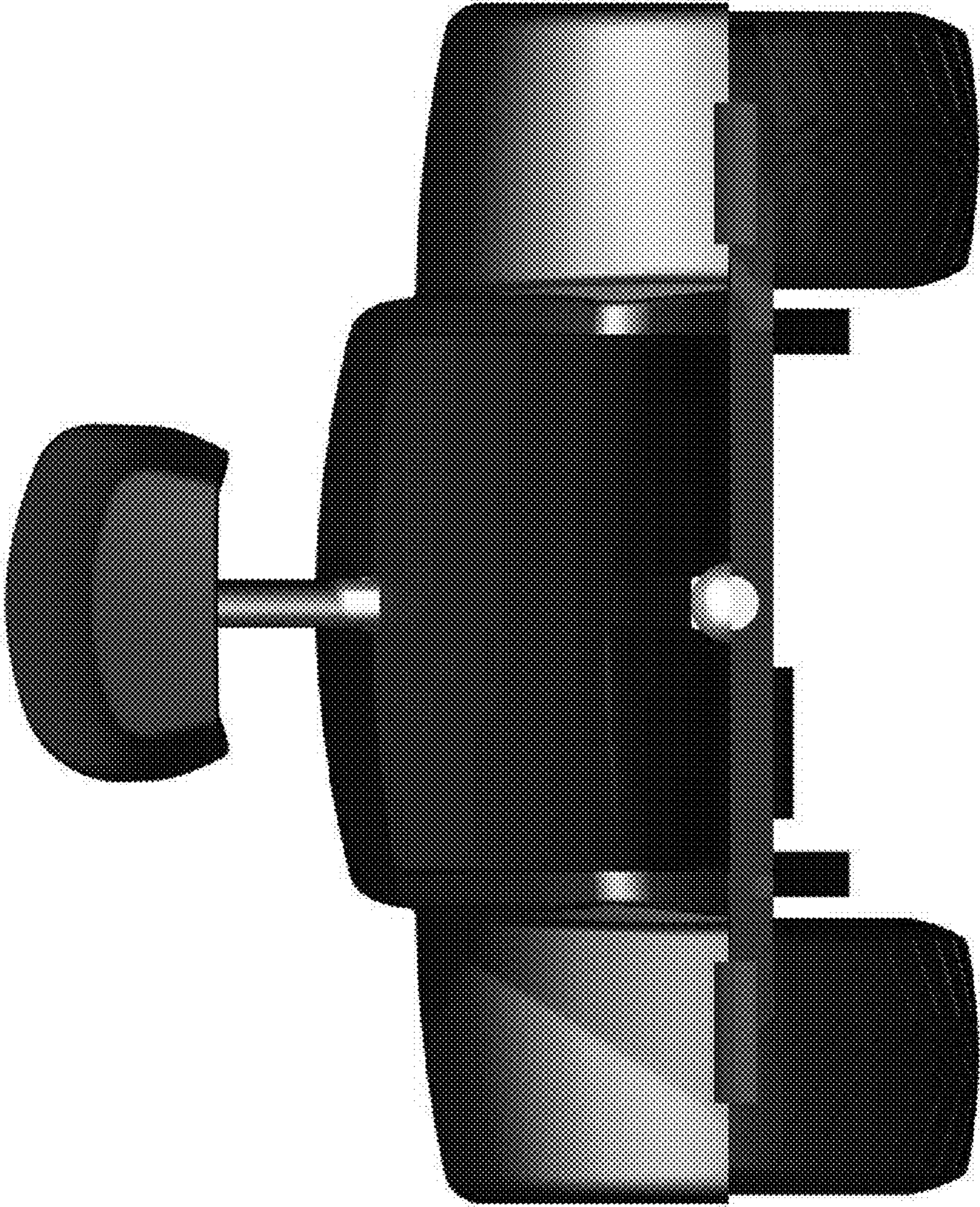

FIG. 7



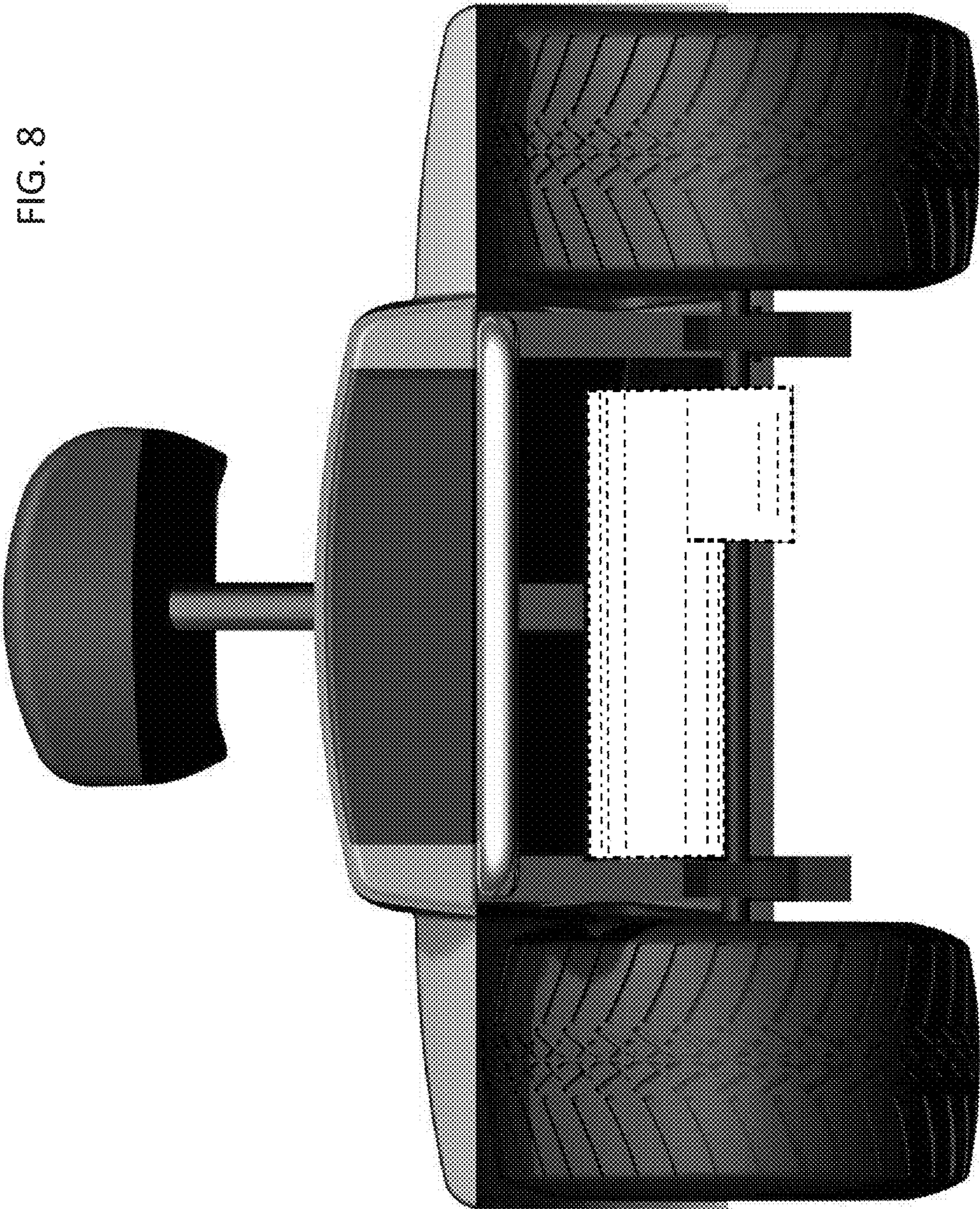

FIG. 8

FIG. 9

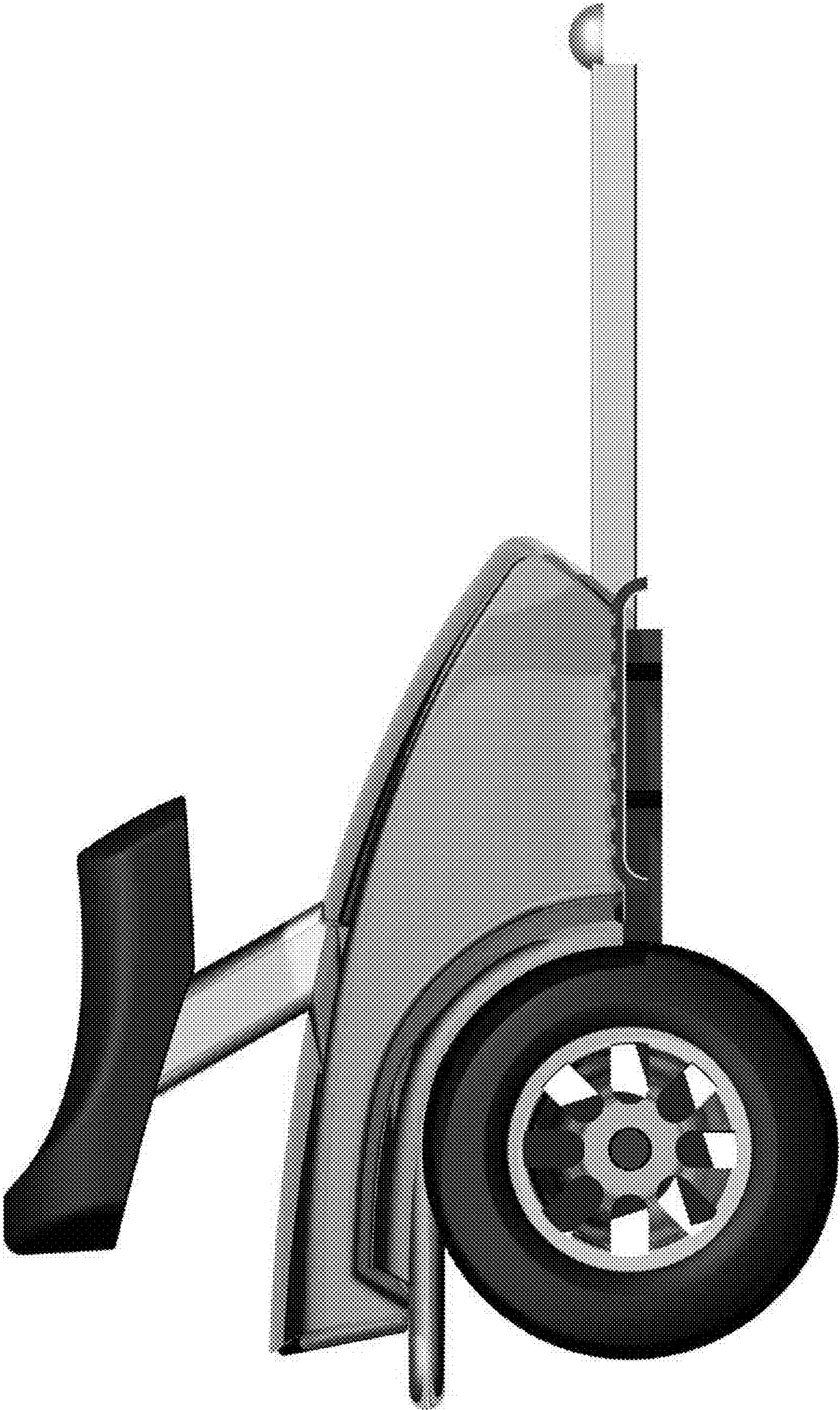

FIG. 10

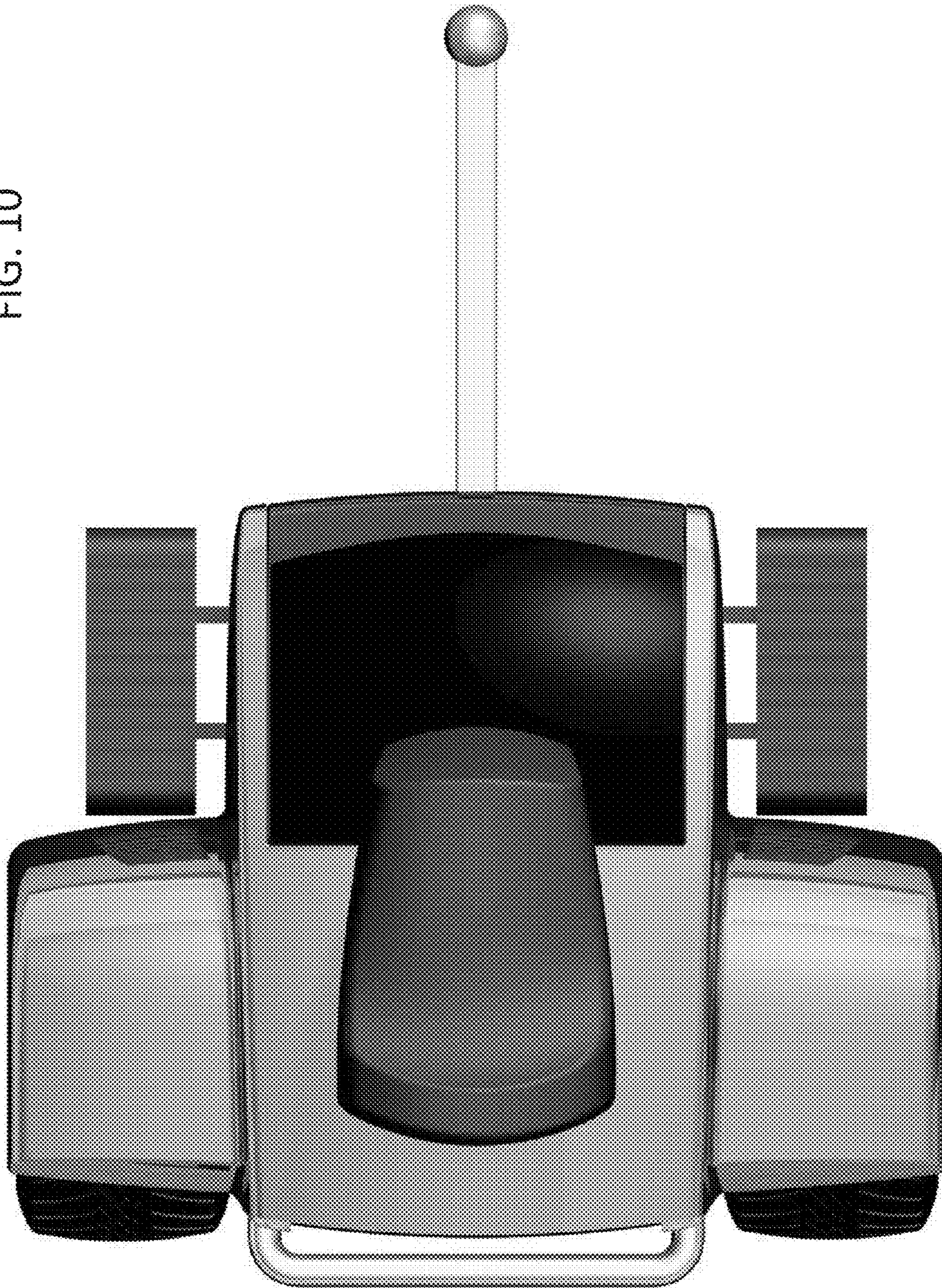



FIG. 11

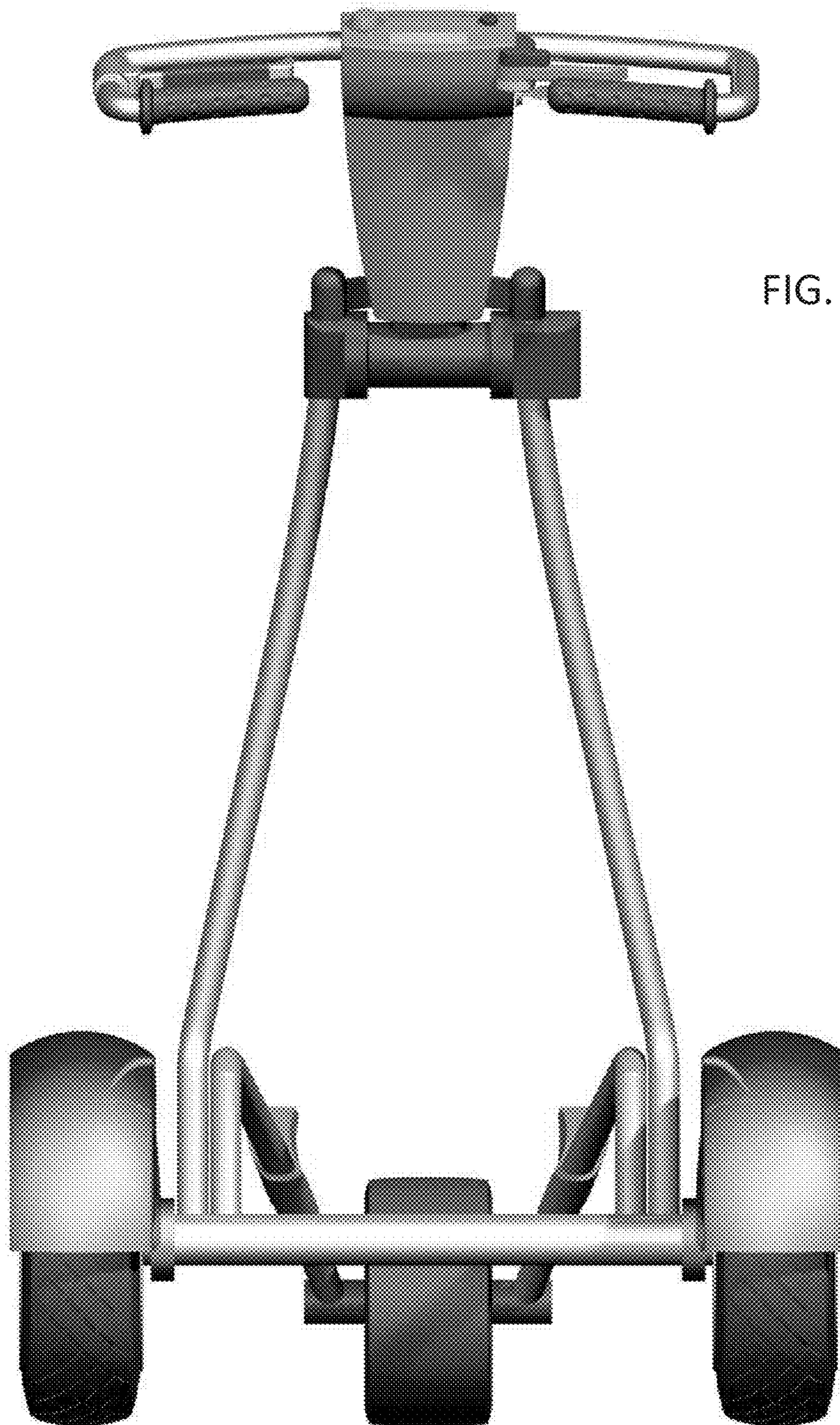

FIG. 12



FIG. 13

FIG. 14

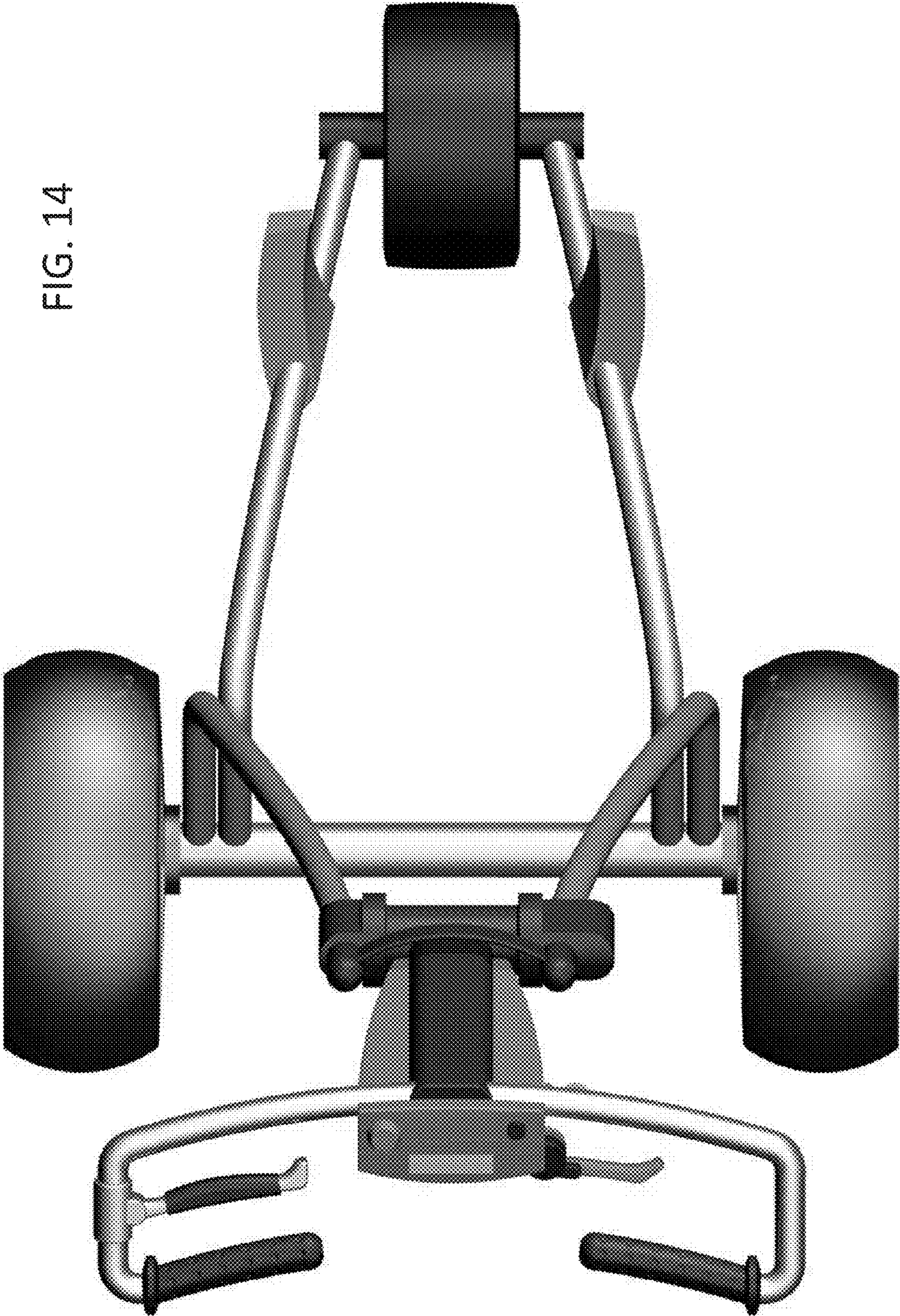

FIG. 15

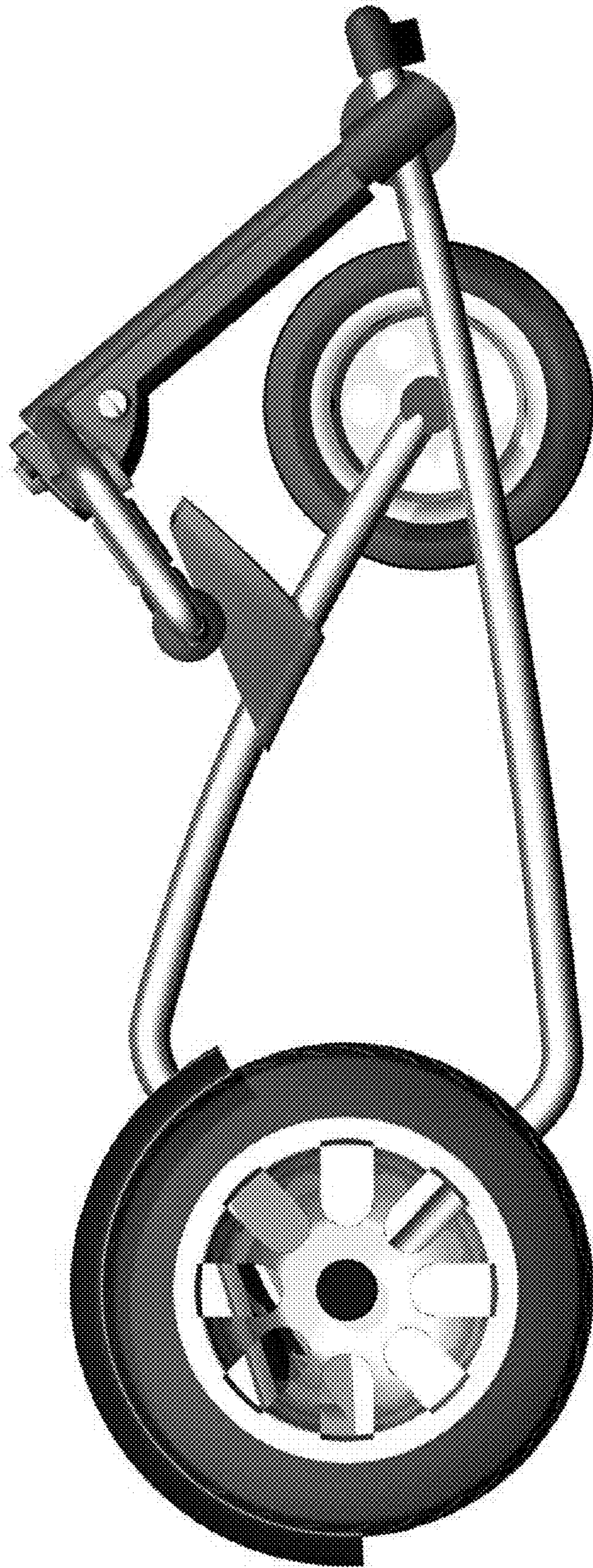

FIG. 16

