



US00D694579S

(12) **United States Design Patent**
Khubani

(10) **Patent No.:** **US D694,579 S**

(45) **Date of Patent:** **** Dec. 3, 2013**

(54) **REFILLABLE FILTER CUP FOR SINGLE SERVE BEVERAGE BREWER**

D524,599 S * 7/2006 Bodum D7/400
D669,309 S * 10/2012 de Klein D7/400
D677,120 S * 3/2013 DeMiglio et al. D7/400

(75) Inventor: **Bobby Khubani**, Edgewater, NJ (US)

* cited by examiner

(73) Assignee: **Telebrands Corp.**, Fairfield, NJ (US)

Primary Examiner — Marianne Pandozzi

(**) Term: **14 Years**

(74) *Attorney, Agent, or Firm* — Cooper & Dunham LLP

(21) Appl. No.: **29/423,968**

(57) **CLAIM**

The ornamental design for a refillable filter cup for single serve beverage brewer, as shown described.

(22) Filed: **Jun. 6, 2012**

DESCRIPTION

(51) **LOC (9) Cl.** **07-99**

(52) **U.S. Cl.**

USPC **D7/400**

(58) **Field of Classification Search**

USPC D7/399, 400, 667, 392; D23/261;
4/290; 210/477; 99/287, 299, 306, 300;
426/77; D9/428, 440, 439

See application file for complete search history.

FIG. 1 is an elevational view of one side (the opposite side is identical thereto) of a refillable filter cup for single serve beverage brewer, showing my new design;
FIG. 2 is a top perspective view thereof;
FIG. 3 is a bottom perspective view thereof;
FIG. 4 is an elevational view of the aforesaid one side thereof with the lid open;
FIG. 5 is a top perspective view thereof with the lid open;
FIG. 6 is a top plan view thereof;
FIG. 7 is a top plan view thereof with the lid open;
FIG. 8 is a bottom plan view thereof;
FIG. 9 is a rear elevational view thereof; and,
FIG. 10 is a front elevational view thereof.

(56) **References Cited**

U.S. PATENT DOCUMENTS

5,125,327 A * 6/1992 Winnington-Ingram 99/306
D330,992 S * 11/1992 Kleek D7/400
D349,211 S * 8/1994 Cerato D7/400
D514,398 S * 2/2006 Feil D7/667

1 Claim, 10 Drawing Sheets

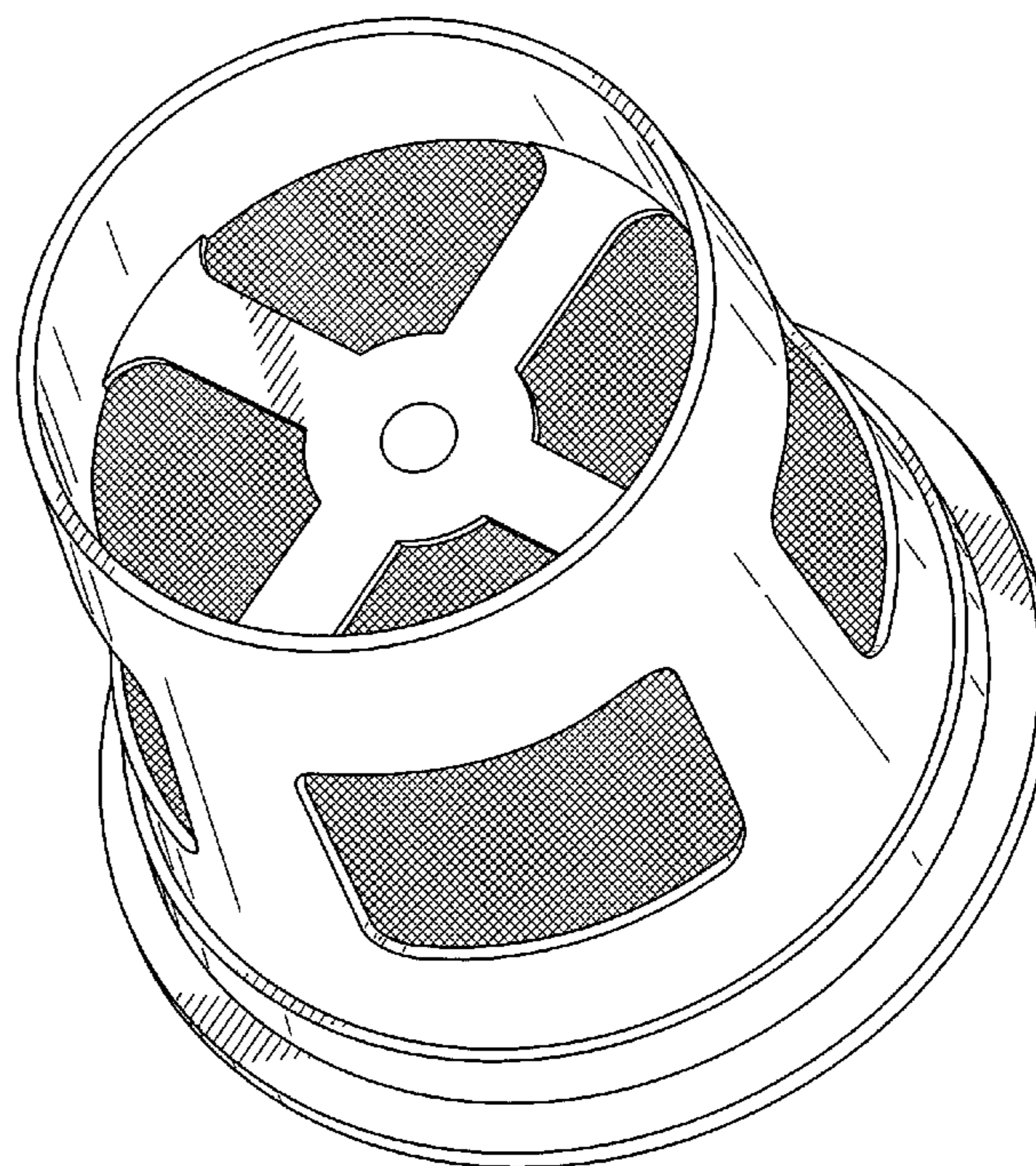
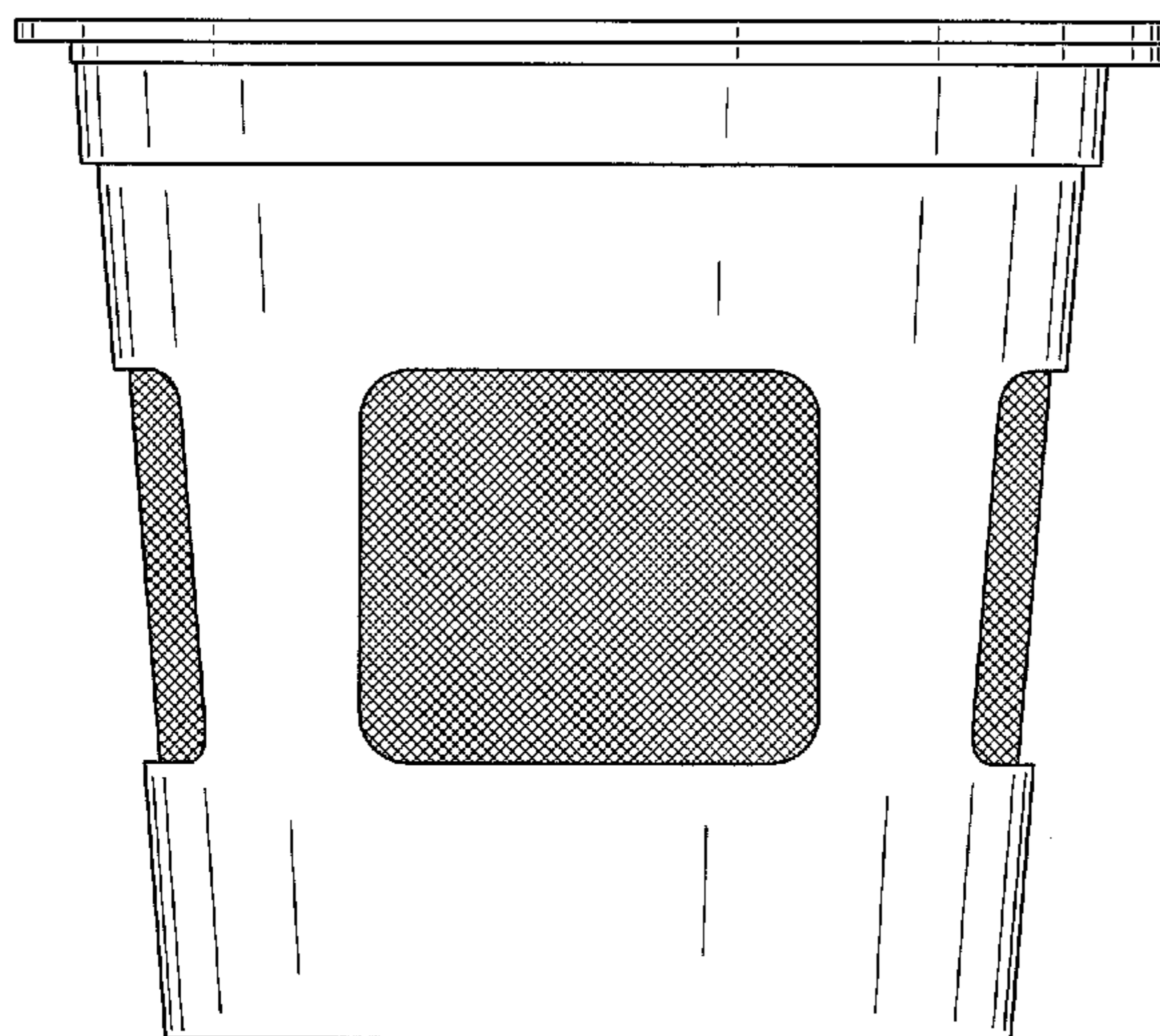

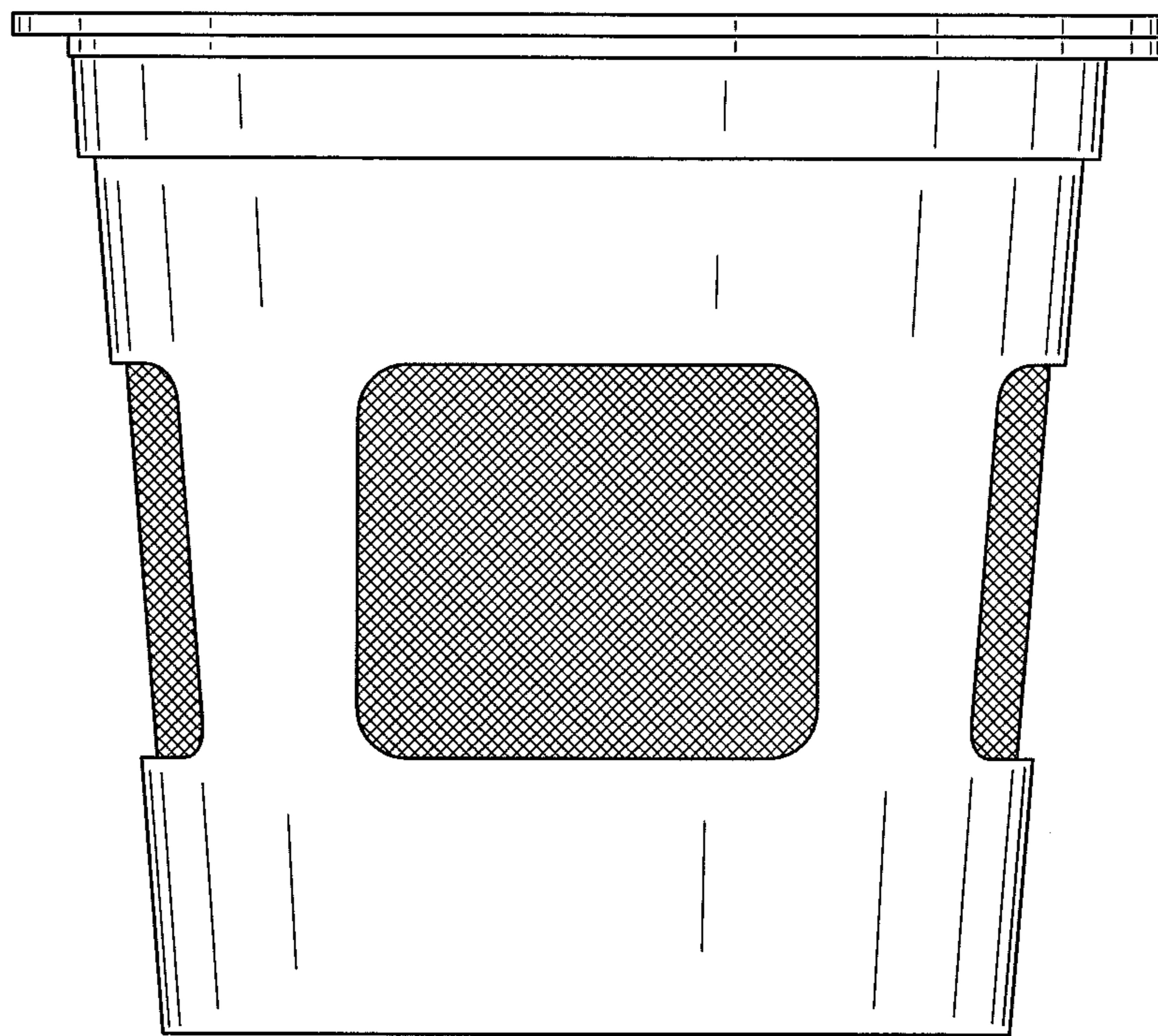

FIG. 1

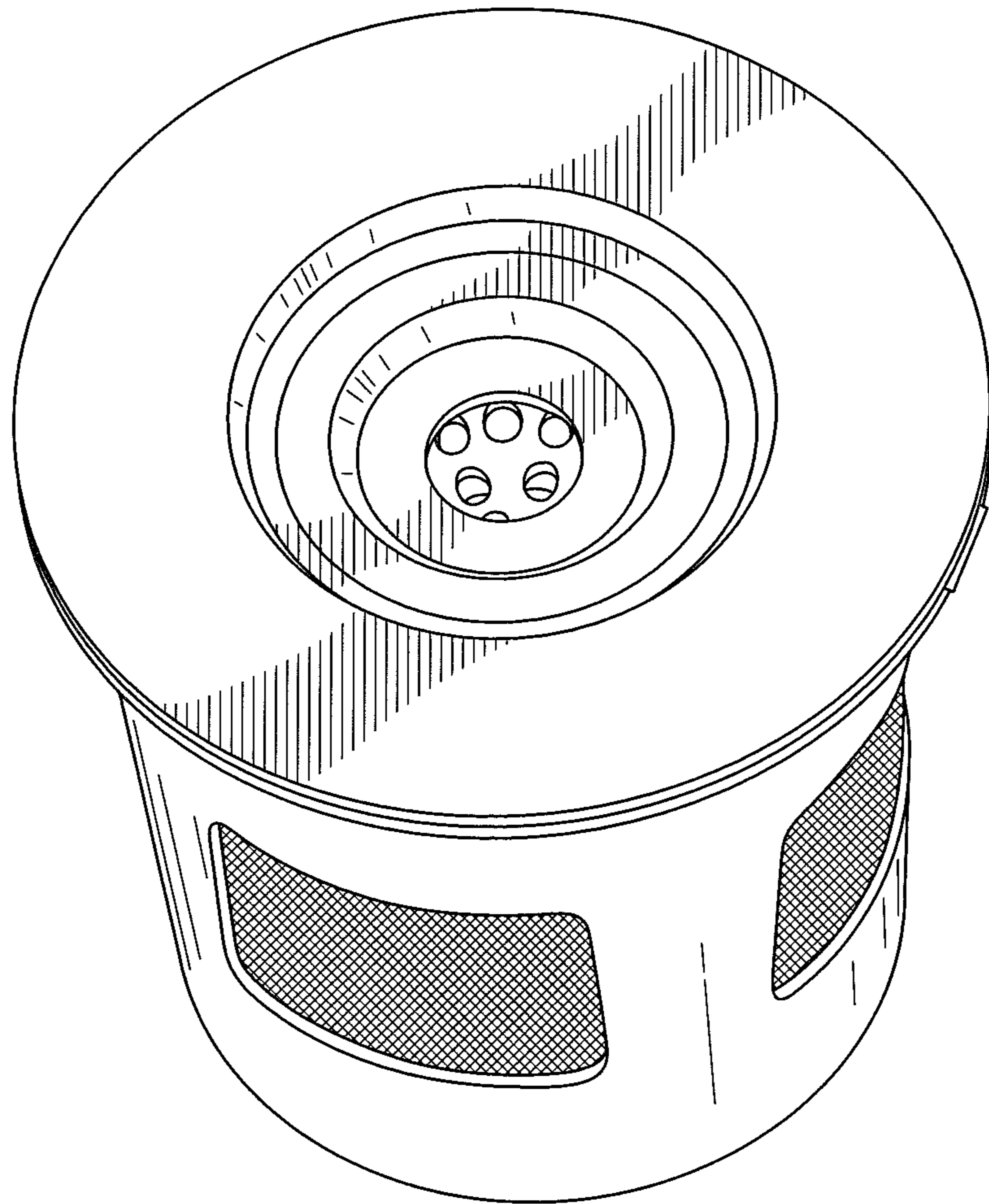

FIG. 2

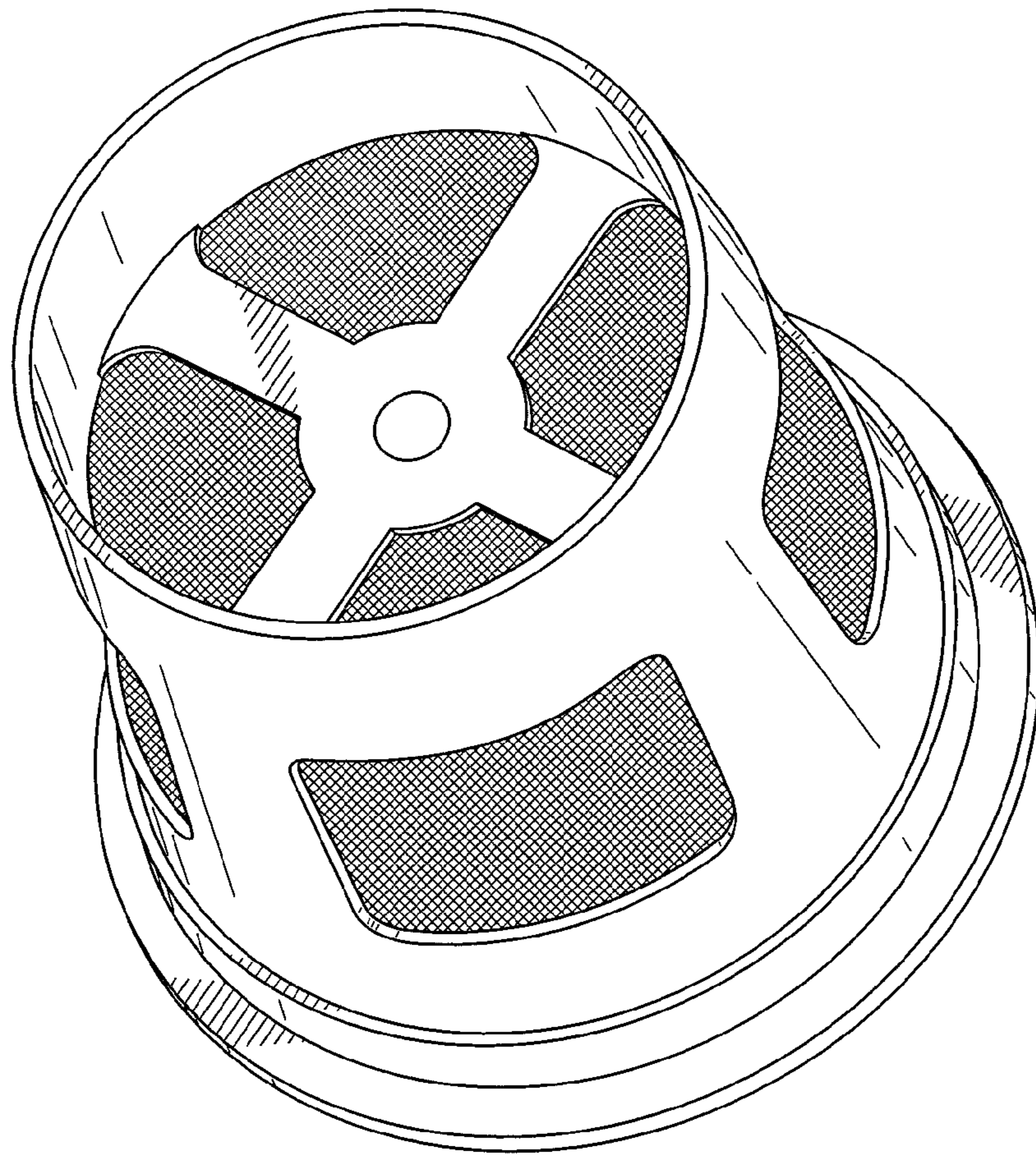

FIG. 3

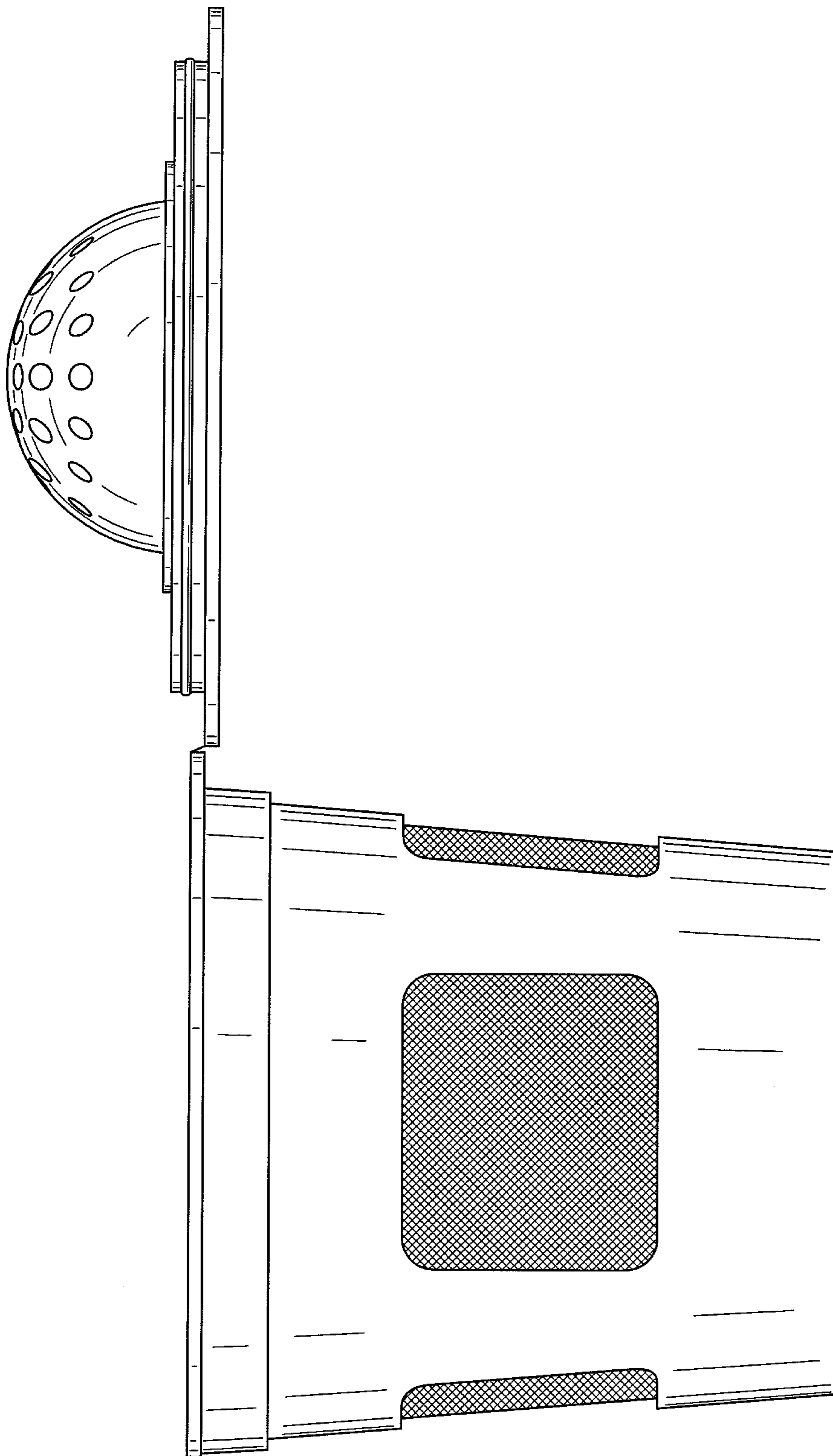

FIG. 4

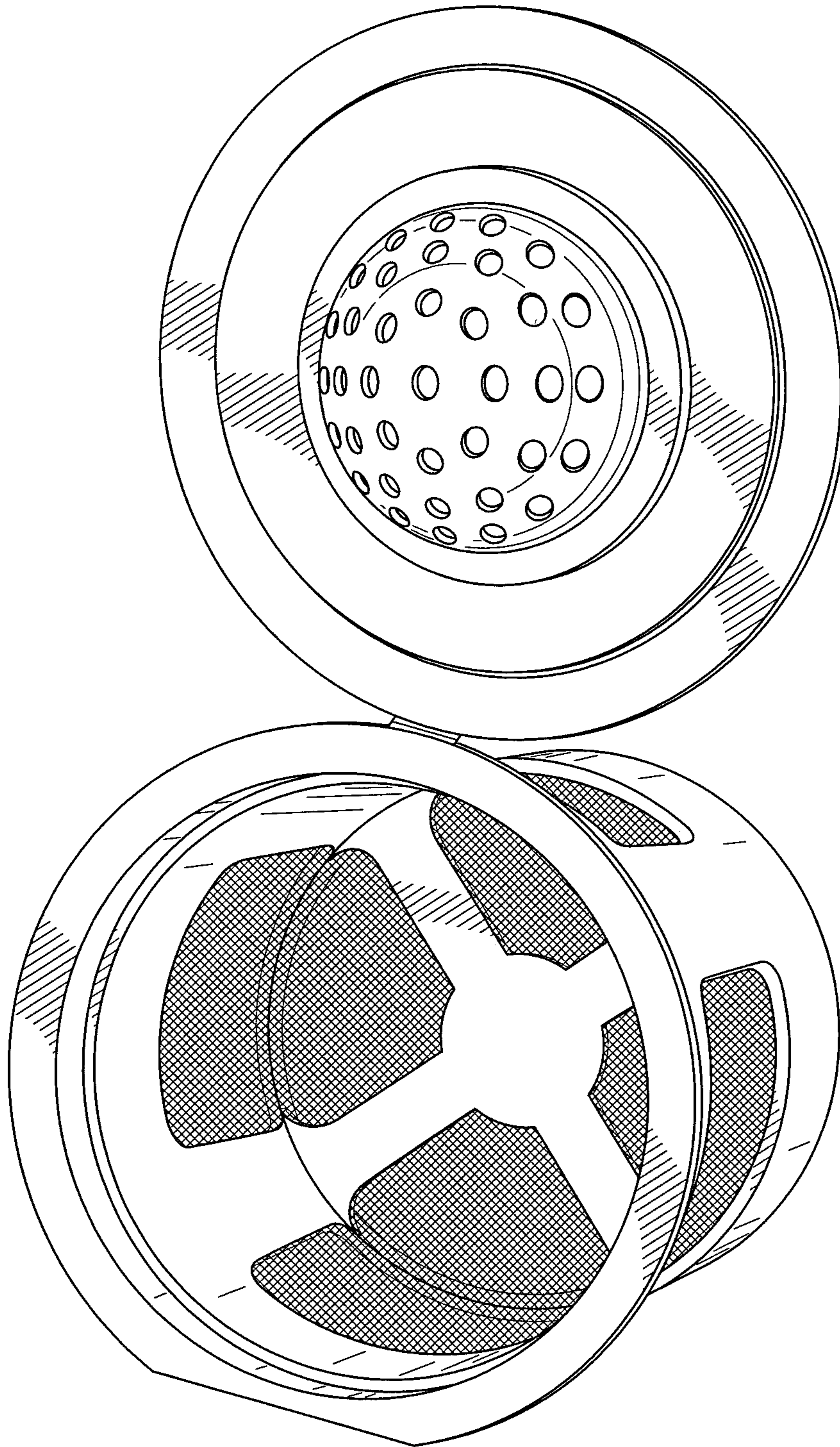

FIG. 5

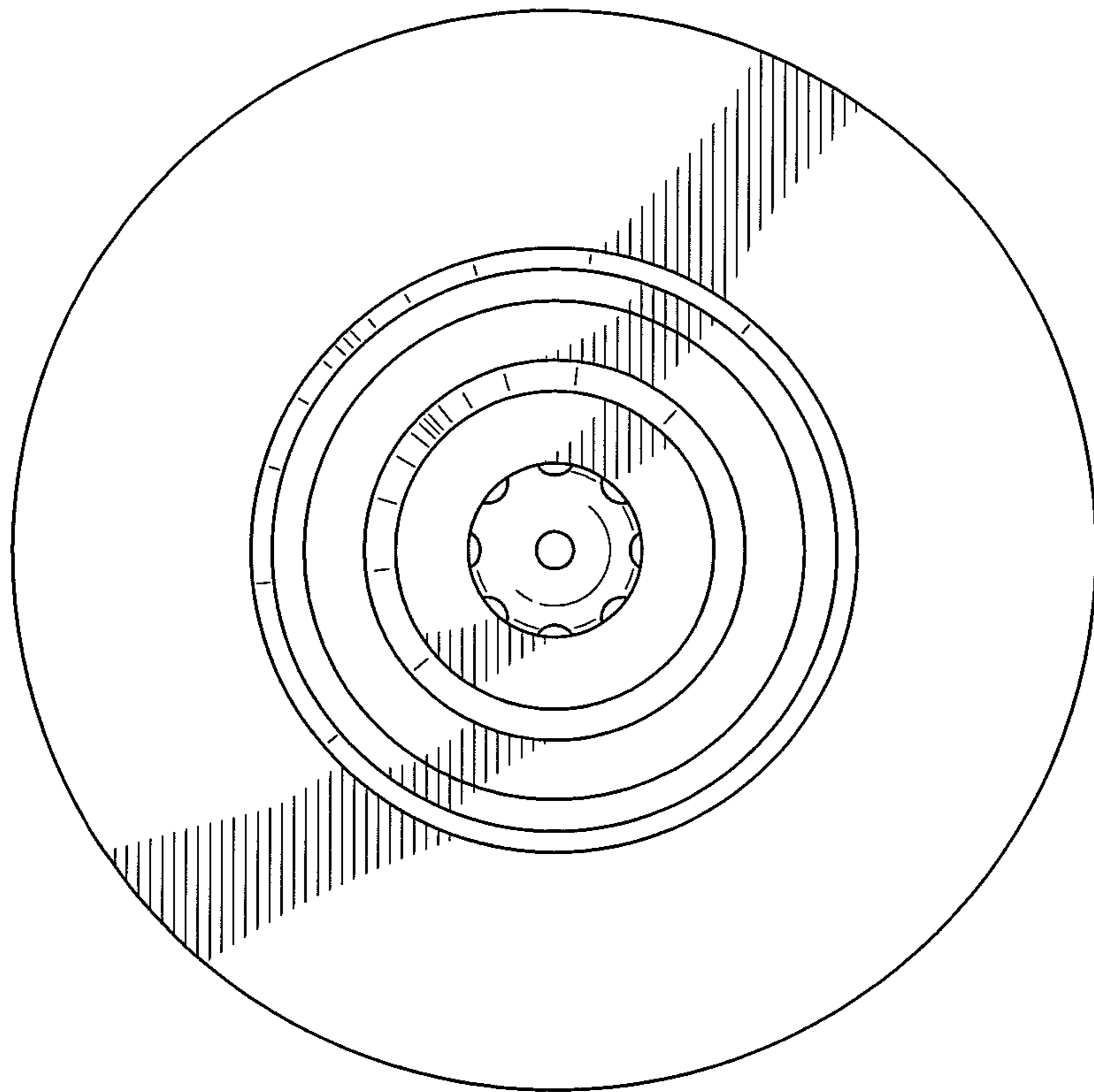

FIG. 6

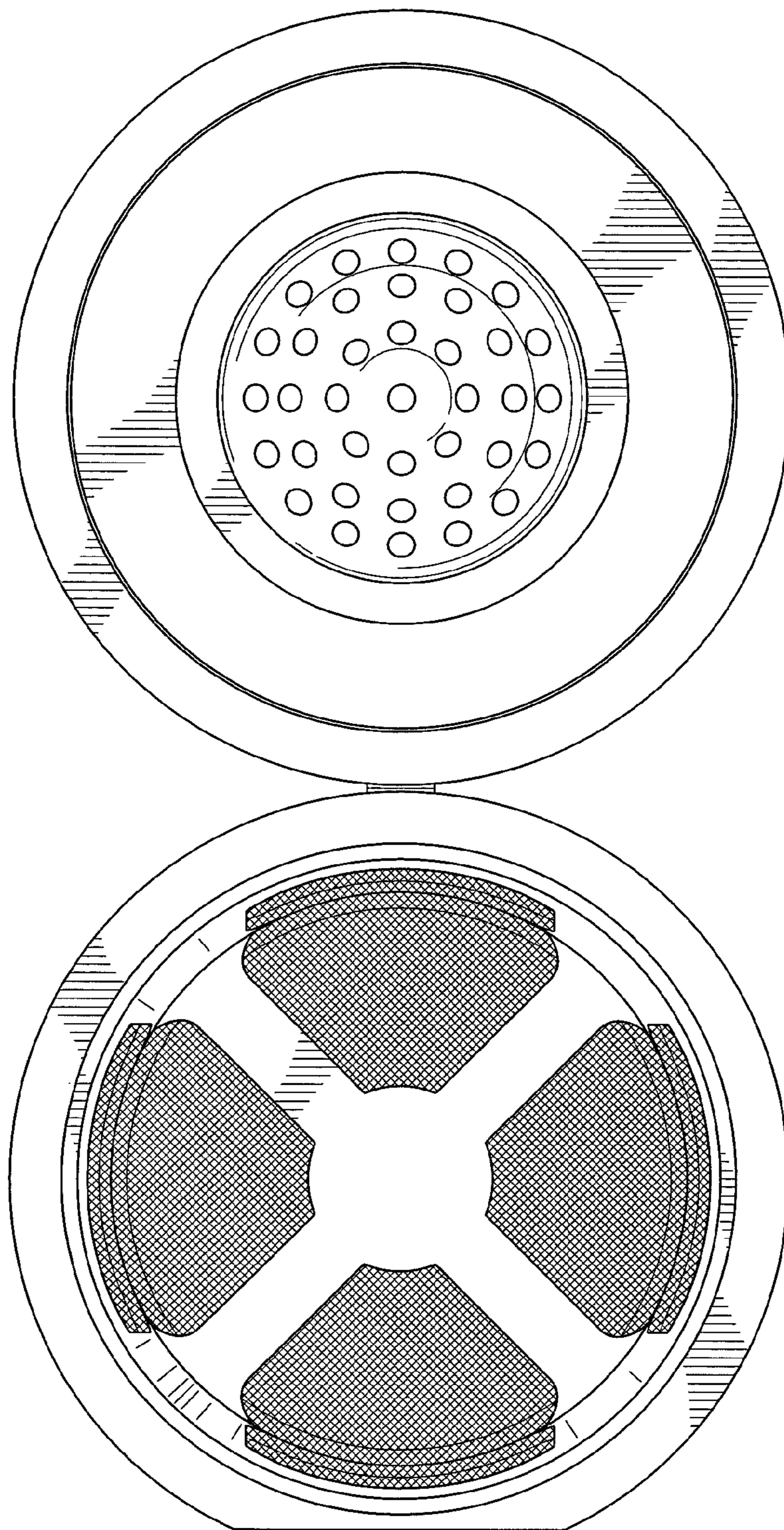

FIG. 7

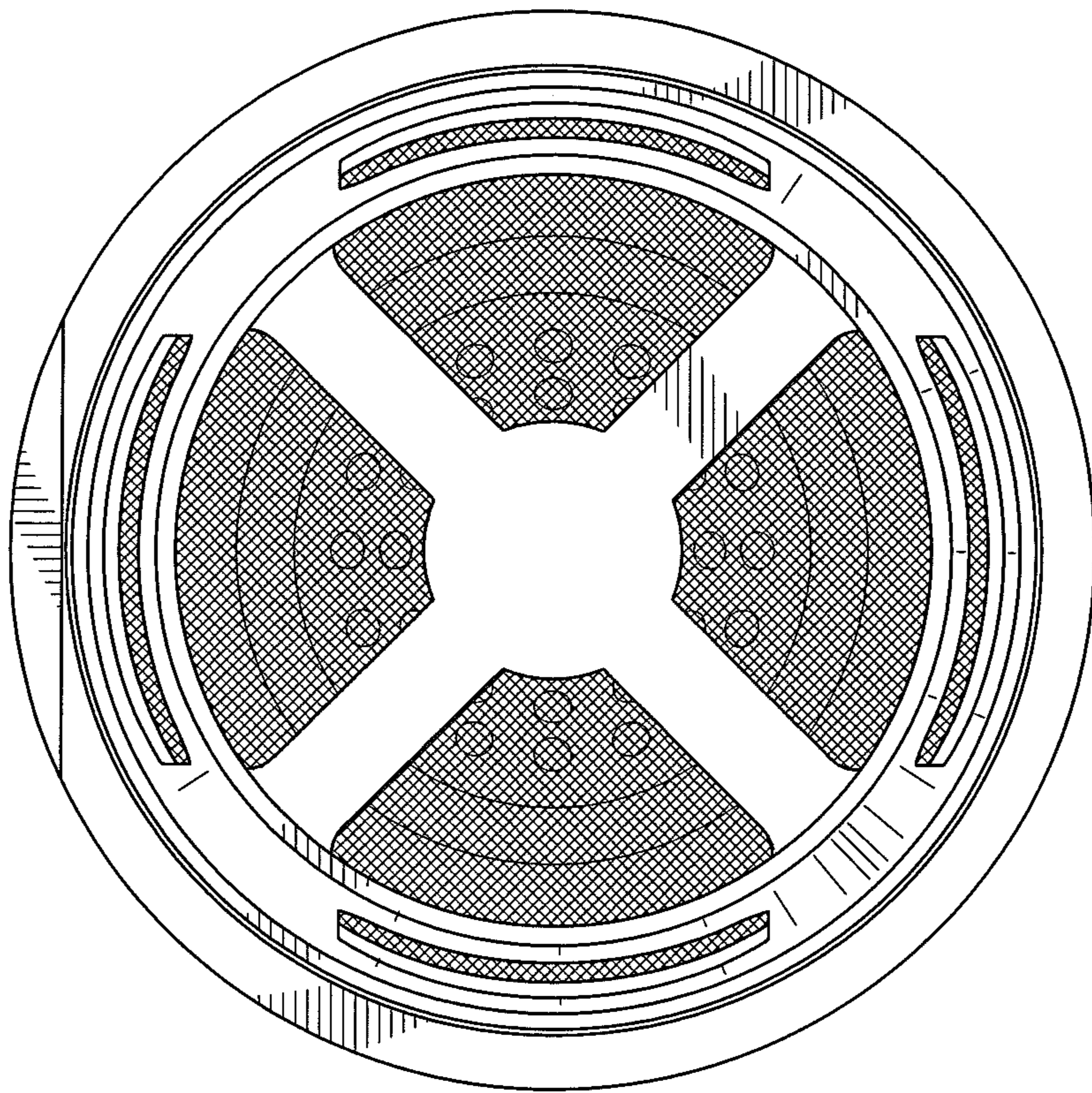

FIG. 8

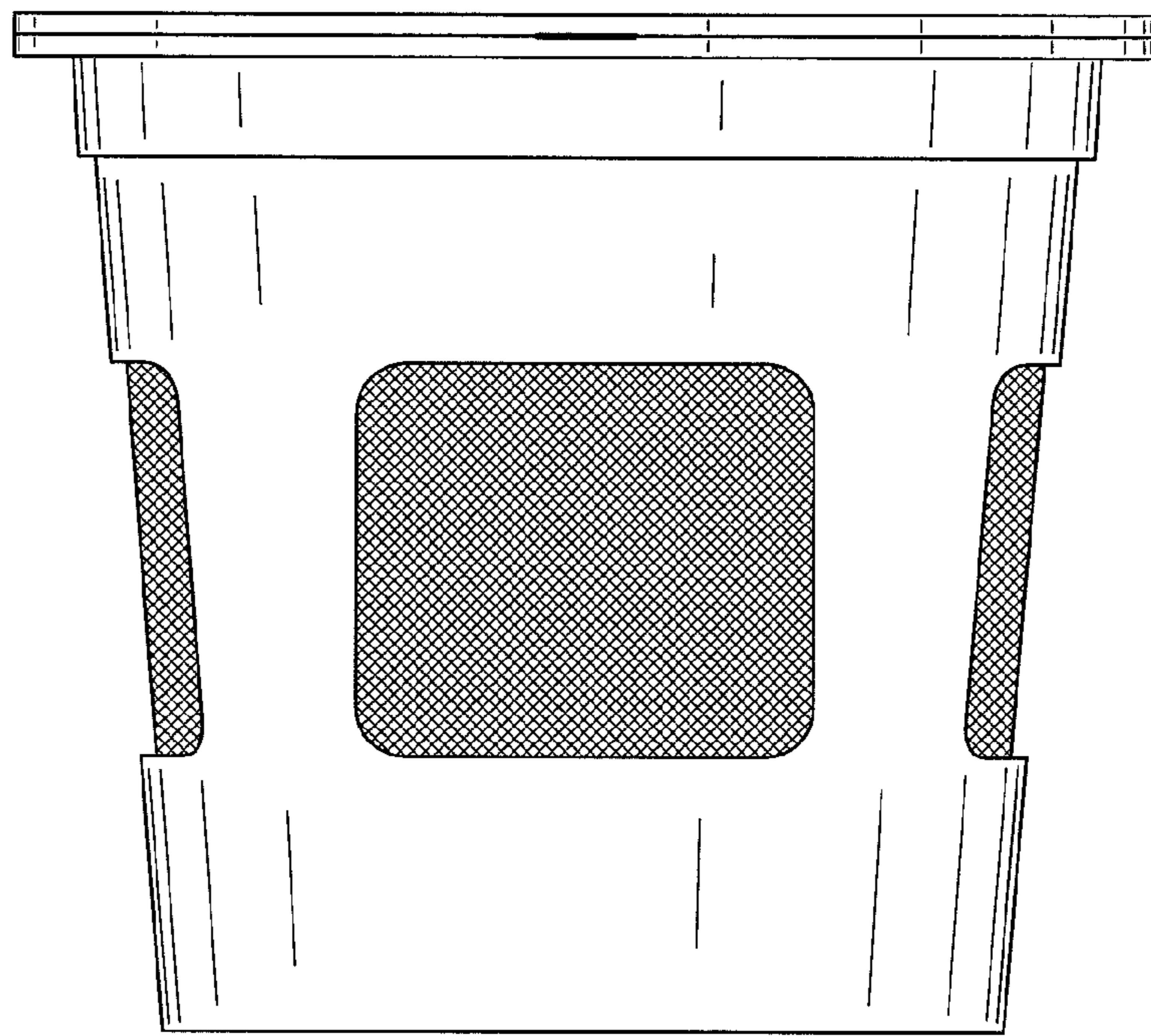

FIG. 9

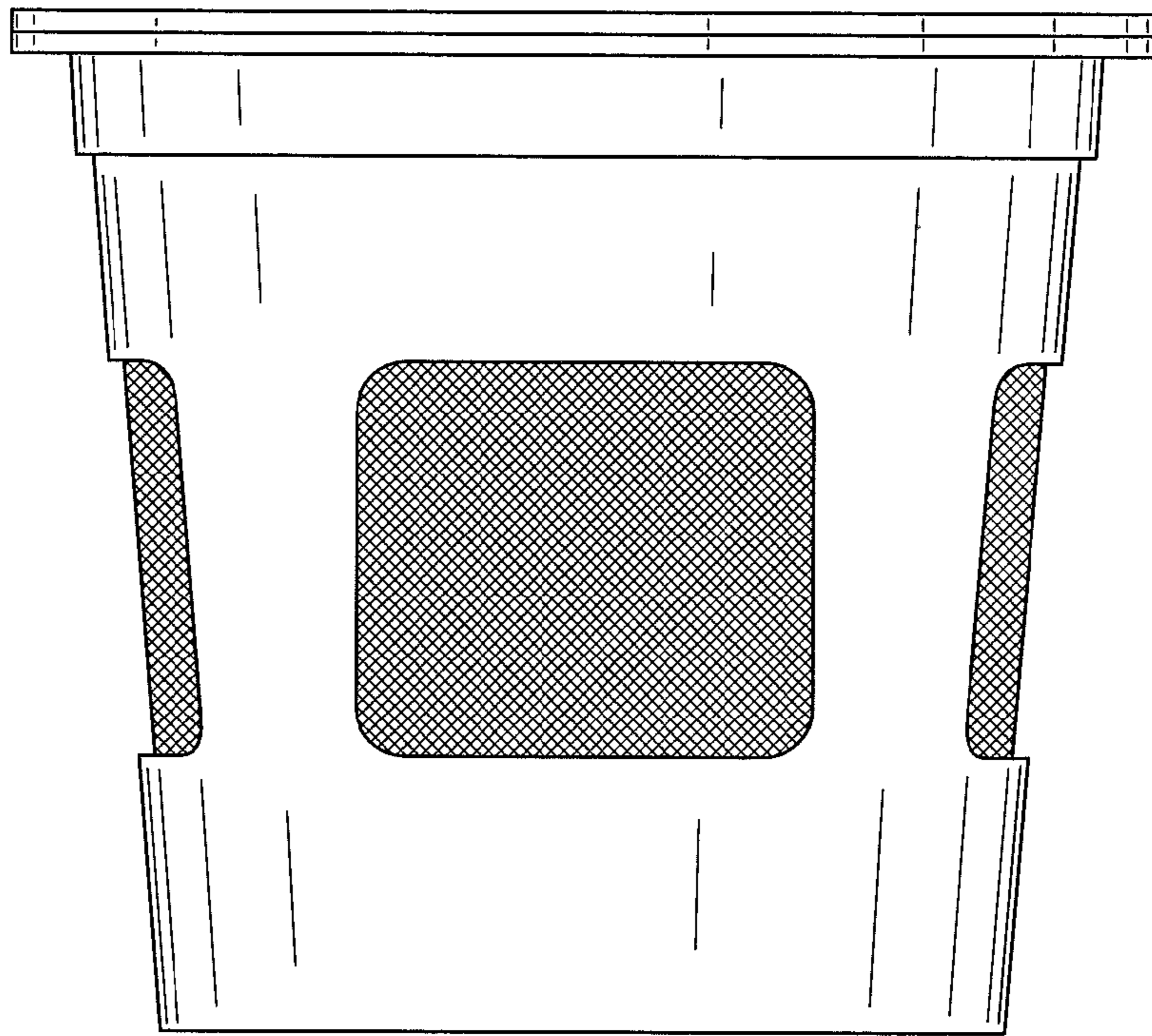

FIG. 10