



US00D694398S

(12) **United States Design Patent**  
**Taylor et al.**

(10) **Patent No.:** **US D694,398 S**  
(45) **Date of Patent:** **\*\* Nov. 26, 2013**

(54) **POWERED IRRIGATOR FOR SINUS CAVITY RINSE**

2,107,686 A 2/1938 Bramsen et al.  
2,115,959 A 5/1938 Lewis  
2,571,921 A 10/1951 Morris

(71) Applicant: **Water Pik, Inc.**, Fort Collins, CO (US)

(Continued)

(72) Inventors: **Kurt M. Taylor**, Fort Collins, CO (US);  
**Kenneth A. Hair**, Fort Collins, CO (US)

FOREIGN PATENT DOCUMENTS

(73) Assignee: **Water Pik, Inc.**, Fort Collins, CO (US)

CA 851479 9/1970  
CH 655237 4/1987

(\*\*) Term: **14 Years**

(Continued)

(21) Appl. No.: **29/436,380**

OTHER PUBLICATIONS

(22) Filed: **Nov. 5, 2012**

The Right Tool, Electron Fusion Devices, Inc., 2 pages, at least as early as Feb. 1991.

(Continued)

**Related U.S. Application Data**

(63) Continuation of application No. 29/381,243, filed on Dec. 16, 2010, now Pat. No. Des. 670,373.

*Primary Examiner* — Wan Laymon

(51) **LOC (9) Cl.** ..... **24-01**

(74) *Attorney, Agent, or Firm* — Dorsey & Whitney LLP

(52) **U.S. Cl.**  
USPC ..... **D24/108**; D24/111

(57) **CLAIM**

We claim the ornamental design for a powered irrigator for sinus cavity rinse, substantially as shown and described.

(58) **Field of Classification Search**  
USPC ..... D24/108, 110, 111; D7/312, 321;  
D4/101; D9/723-724, 529, 551;  
222/211-212; 433/80, 85, 89; 604/30,  
604/73, 93.01, 94.01, 118-119, 121, 125,  
604/151, 275, 153

**DESCRIPTION**

See application file for complete search history.

FIG. 1 is a front isometric view of a powered irrigator for sinus cavity rinse.  
FIG. 2 is a left elevation view of the powered irrigator for sinus cavity rinse of FIG. 1.  
FIG. 3 is a right elevation view of the powered irrigator for sinus cavity rinse of FIG. 1.  
FIG. 4 is a rear elevation view of the powered irrigator for sinus cavity rinse of FIG. 1; and,  
FIG. 5 is a front elevation view of the powered irrigator for sinus cavity rinse of FIG. 1.

The broken lines shown in the figures that are immediately adjacent to the shaded areas represent the bounds of the claimed design while all other broken lines represent environmental structure and are for illustrative purposes only; the broken lines form no part of the claimed design.

(56) **References Cited**

U.S. PATENT DOCUMENTS

465,559 A 12/1891 Good  
555,588 A 3/1896 Spencer  
1,278,225 A 9/1918 Schamberg  
1,498,267 A 6/1924 Nachman  
1,650,686 A 11/1927 Binks  
1,681,320 A 8/1928 Bergl et al.  
1,933,454 A 10/1933 Sidney

**1 Claim, 5 Drawing Sheets**

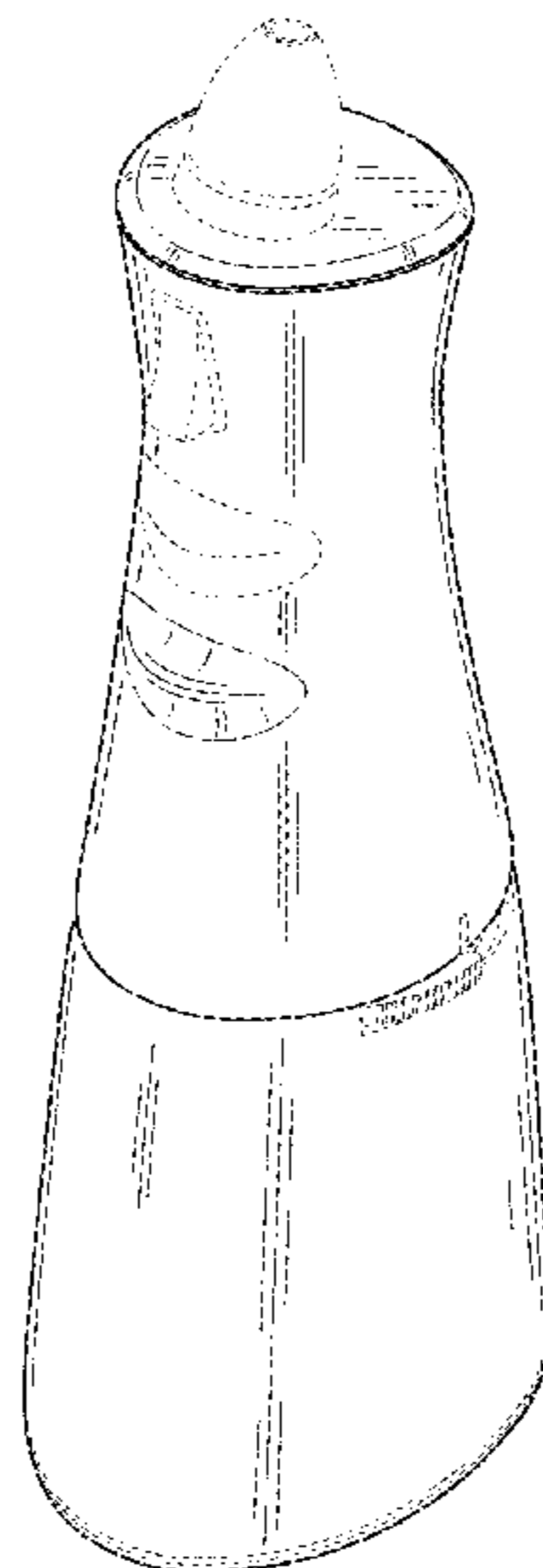

(56)

## References Cited

## U.S. PATENT DOCUMENTS

2,578,864 A	12/1951	Tupper	4,160,383 A	7/1979	Rauschenberger
D169,996 S	7/1953	Vuillement	4,182,038 A	1/1980	Fleer
2,669,233 A	2/1954	Friend	4,201,200 A	5/1980	Hubner
2,794,437 A	6/1954	Tash	4,215,476 A	8/1980	Armstrong
2,722,458 A	11/1955	Wahlin	4,219,618 A	8/1980	Leonard
2,783,919 A	3/1957	Ansell	4,227,878 A	10/1980	Lohn
2,811,283 A	10/1957	Bowen	4,229,634 A	10/1980	Hickman et al.
2,984,452 A	5/1961	Hooper	4,236,889 A	12/1980	Wright
2,987,261 A	6/1961	McCuiaston et al.	4,248,589 A	2/1981	Lewis
3,089,490 A	5/1963	Goldberg	4,249,899 A	2/1981	Davis
3,096,913 A	7/1963	Jousson	4,262,799 A	4/1981	Perrett
3,144,867 A	8/1964	Trupp et al.	4,266,934 A	5/1981	Pernot
3,176,883 A	4/1965	Davis, Jr.	4,276,023 A	6/1981	Phillips et al.
3,209,956 A	10/1965	McKenzie	4,276,880 A	7/1981	Malmin
3,216,619 A	11/1965	Richards et al.	4,302,186 A	11/1981	Cammack et al.
3,225,759 A	12/1965	Drapen et al.	4,303,064 A	12/1981	Buffa
3,227,158 A	1/1966	Mattingly	4,303,070 A	12/1981	Ichikawa et al.
3,297,558 A	1/1967	Hillquist	4,315,741 A	2/1982	Reichl
D208,778 S	10/1967	Koch	4,319,568 A	3/1982	Tregoning
D209,395 S	11/1967	Gilbert	4,331,422 A	5/1982	Heyman
3,370,214 A	2/1968	Aymar	4,337,040 A	6/1982	Cammack et al.
3,391,696 A	7/1968	Woodward	4,340,365 A	7/1982	Pisanu
3,400,999 A	9/1968	Goldstein	4,340,368 A	7/1982	Lococo
3,418,552 A	12/1968	Holmes	D266,117 S	9/1982	Oberheim
3,420,228 A	1/1969	Kalbfeld	4,363,626 A	12/1982	Schmidt et al.
3,453,969 A	7/1969	Mattingly	4,365,376 A	12/1982	Oda et al.
3,465,751 A	9/1969	Powers	4,370,131 A	1/1983	Banko
3,487,828 A	1/1970	Troy	4,374,354 A	2/1983	Petrovic et al.
3,489,268 A	1/1970	Meierhoefer	4,382,167 A	5/1983	Maruyama et al.
3,496,933 A	2/1970	Lloyd	4,382,786 A	5/1983	Lohn
3,499,440 A	3/1970	Gibbs	D270,000 S	8/1983	Ketler
3,501,203 A	3/1970	Falk	4,412,823 A	11/1983	Sakai et al.
3,502,072 A	3/1970	Stillman	4,442,830 A	4/1984	Markau
3,517,669 A	6/1970	Buono et al.	4,442,831 A	4/1984	Trenary
D218,270 S	8/1970	Soper	4,452,238 A	6/1984	Kerr
3,522,801 A	8/1970	Robinson	4,454,866 A	6/1984	Fayen
3,536,065 A	10/1970	Moret	4,512,769 A	4/1985	Kozam et al.
3,537,444 A	11/1970	Garn	4,517,962 A	5/1985	Heckele
3,538,950 A	11/1970	Porteners	4,531,912 A	7/1985	Schuss et al.
3,547,110 A	12/1970	Balamuth	4,531,913 A	7/1985	Taguchi
3,572,375 A	3/1971	Rosenberg	4,534,340 A	8/1985	Kerr et al.
3,578,884 A	5/1971	Jacobson	4,552,130 A	11/1985	Kinoshita
3,583,609 A	6/1971	Oppenheimer	D283,374 S	4/1986	Cheuk-Yiu
3,590,813 A	7/1971	Roszyk	4,585,415 A	4/1986	Hommann
3,608,548 A	9/1971	Lewis	4,591,777 A	5/1986	McCarty et al.
3,636,947 A	1/1972	Balamuth	4,592,728 A	6/1986	Davis
3,651,576 A	3/1972	Massa	4,602,906 A	7/1986	Grunenfelder
3,669,101 A	6/1972	Kleiner	4,607,627 A	8/1986	Leber et al.
3,703,170 A	11/1972	Ryckman, Jr.	4,613,074 A	9/1986	Schulze
3,747,595 A	7/1973	Grossan	4,619,612 A	10/1986	Weber et al.
3,768,472 A	10/1973	Hodosh et al.	4,629,425 A	12/1986	Detsch
3,783,364 A	1/1974	Gallanis et al.	4,636,198 A	1/1987	Stade
3,809,977 A	5/1974	Balamuth et al.	4,644,937 A	2/1987	Hommann
3,820,532 A	6/1974	Eberhardt et al.	4,645,488 A	2/1987	Matukas
3,827,147 A	8/1974	Condon	4,647,831 A	3/1987	O'Malley et al.
3,840,795 A	10/1974	Roszyk et al.	4,648,838 A	3/1987	Schlachter
3,854,209 A	12/1974	Franklin et al.	4,650,475 A	3/1987	Smith et al.
3,874,506 A	4/1975	Hill et al.	4,655,198 A	4/1987	Hommann
3,912,125 A	10/1975	Acklin	4,669,453 A	6/1987	Atkinson et al.
3,943,628 A	3/1976	Kronman et al.	4,672,953 A	6/1987	DiVito
3,973,558 A	8/1976	Stouffer et al.	4,673,396 A	6/1987	Urbaniak
4,001,526 A	1/1977	Olson	D291,354 S	8/1987	Camens
4,004,302 A	1/1977	Hori	4,716,352 A	12/1987	Hurn et al.
4,007,739 A	2/1977	Bron et al.	4,770,632 A	9/1988	Ryder et al.
D246,667 S	12/1977	Mackay et al.	4,783,321 A	11/1988	Spence
4,060,870 A	12/1977	Cannarella	4,787,845 A	11/1988	Valentine
4,075,761 A	2/1978	Behne et al.	4,787,847 A	11/1988	Martin et al.
4,078,558 A	3/1978	Woog et al.	4,798,292 A	1/1989	Hauze
4,108,167 A	8/1978	Hickman et al.	4,803,974 A	2/1989	Powell
4,108,178 A	8/1978	Betush	4,804,364 A	2/1989	Dieras et al.
4,109,650 A	8/1978	Peclard	4,818,229 A	4/1989	Vasile
4,141,352 A	2/1979	Ebner et al.	4,820,152 A	4/1989	Warrin et al.
4,144,646 A	3/1979	Takemoto et al.	4,821,923 A	4/1989	Skorka
4,149,315 A	4/1979	Page, Jr. et al.	4,824,368 A	4/1989	Hickman
4,154,375 A	5/1979	Bippus	4,826,431 A	5/1989	Fujimura et al.
			4,832,683 A	5/1989	Idemoto et al.
			4,854,869 A	8/1989	Lawhorn
			4,861,340 A	8/1989	Smith et al.
			4,862,876 A	9/1989	Lih-Sheng



(56)

## References Cited

## U.S. PATENT DOCUMENTS

4,869,720 A	9/1989	Chernack	5,317,691 A	5/1994	Traeger
4,880,382 A	11/1989	Moret et al.	5,321,865 A	6/1994	Kaeser
4,886,452 A	12/1989	Lohn	5,331,704 A	7/1994	Rosen et al.
4,900,252 A	2/1990	Liefke et al.	5,344,317 A	9/1994	Pacher et al.
4,902,225 A	2/1990	Lohn	5,346,677 A	9/1994	Risk
4,903,687 A	2/1990	Lih-Sheng	D351,892 S	10/1994	Wolf et al.
4,906,187 A	3/1990	Amadera	5,360,338 A	11/1994	Waggoner
4,907,744 A	3/1990	Jousson	5,368,548 A	11/1994	Jousson
4,925,450 A	5/1990	Imonti et al.	5,370,534 A	12/1994	Wolf et al.
4,928,675 A	5/1990	Thornton	D354,168 S	1/1995	Hartwein
4,930,660 A	6/1990	Porteous	5,378,149 A	1/1995	Stropko
4,941,459 A	7/1990	Mathur	5,380,201 A	1/1995	Kawata
4,950,159 A	8/1990	Hansen	D356,864 S	3/1995	Woog
4,958,629 A	9/1990	Peace et al.	5,399,089 A	3/1995	Eichman et al.
4,958,751 A	9/1990	Curtis et al.	D358,883 S	5/1995	Vos
4,961,698 A	10/1990	Vlock	5,456,672 A	10/1995	Diederich et al.
4,966,551 A	10/1990	Betush	5,465,445 A	11/1995	Yeh
4,969,874 A	11/1990	Michel et al.	5,468,148 A	11/1995	Ricks
4,973,247 A	11/1990	Varnes et al.	5,470,305 A	11/1995	Arnett et al.
4,973,250 A	11/1990	Milman	5,474,450 A	12/1995	Chronister
4,975,054 A	12/1990	Esrock	5,474,451 A	12/1995	Dalrymple et al.
4,979,503 A	12/1990	Chernack	5,476,379 A	12/1995	Disel
4,979,504 A	12/1990	Mills	5,484,281 A	1/1996	Renow et al.
4,989,590 A	2/1991	Baum et al.	5,487,877 A	1/1996	Choi
4,998,880 A	3/1991	Nerli	5,490,779 A	2/1996	Malmin
5,013,241 A	5/1991	Von Gutfeld et al.	5,505,916 A	4/1996	Berry, Jr.
5,014,884 A	5/1991	Wunsch	D369,656 S	5/1996	Vos
5,019,054 A	5/1991	Clement et al.	5,525,058 A	6/1996	Gallant et al.
5,027,798 A	7/1991	Primiano	5,526,841 A	6/1996	Detsch et al.
5,029,576 A	7/1991	Evans, Sr.	5,540,587 A	7/1996	Malmin
5,033,961 A	7/1991	Kankler et al.	5,547,374 A	8/1996	Coleman
D318,918 S	8/1991	Hartwein	D373,631 S	9/1996	Maeda et al.
5,046,486 A	9/1991	Grulke et al.	5,554,025 A	9/1996	Kinsel
5,049,071 A	9/1991	Davis et al.	5,556,001 A	9/1996	Weissman et al.
5,060,825 A	10/1991	Palmer et al.	5,564,629 A	10/1996	Weissman et al.
5,064,168 A	11/1991	Raines et al.	5,616,028 A	4/1997	Hafele et al.
5,082,443 A	1/1992	Lohn	5,634,791 A	6/1997	Matsuura et al.
5,086,756 A	2/1992	Powell	5,636,987 A	6/1997	Serfaty
5,095,893 A	3/1992	Rawden, Jr.	5,640,735 A	6/1997	Manning
5,098,291 A	3/1992	Curtis et al.	5,653,591 A	8/1997	Loge
5,125,835 A	6/1992	Young	5,667,483 A	9/1997	Santos
5,127,831 A	7/1992	Bab	5,683,192 A	11/1997	Kilfoil
5,142,723 A	9/1992	Lustig et al.	5,685,829 A	11/1997	Allen
5,150,841 A	9/1992	Silvenis et al.	5,685,851 A	11/1997	Murphy et al.
5,172,810 A	12/1992	Brewer	5,697,784 A	12/1997	Hafele et al.
5,173,273 A	12/1992	Brewer	5,709,545 A	1/1998	Johnston et al.
5,183,035 A	2/1993	Weir	5,716,007 A	2/1998	Nottingham et al.
5,197,458 A	3/1993	Ito et al.	5,718,668 A	2/1998	Arnett et al.
5,197,460 A	3/1993	Ito et al.	5,746,595 A	5/1998	Ford
5,199,871 A	4/1993	Young	5,749,726 A	5/1998	Kinsel
5,203,697 A	4/1993	Malmin	5,759,502 A	6/1998	Spencer et al.
5,203,769 A	4/1993	Clement et al.	5,779,654 A	7/1998	Foley et al.
5,204,004 A	4/1993	Johnston et al.	5,795,153 A	8/1998	Rechmann
5,208,933 A	5/1993	Lustig et al.	5,836,030 A	11/1998	Hazeu et al.
5,218,956 A	6/1993	Handler et al.	5,851,079 A	12/1998	Horstman et al.
5,220,914 A	6/1993	Thompson	D403,511 S	1/1999	Serbinski
5,228,646 A	7/1993	Raines	D406,334 S	3/1999	Rosenthal et al.
5,230,624 A	7/1993	Wolf et al.	5,876,201 A	3/1999	Wilson et al.
5,232,687 A	8/1993	Geimer	5,901,397 A	5/1999	Hafele et al.
5,235,968 A	8/1993	Woog	5,934,902 A	8/1999	Abahusayn
5,241,714 A	9/1993	Barry	D413,975 S	9/1999	Maeda
5,246,367 A	9/1993	Ito et al.	D417,082 S	11/1999	Classen et al.
5,252,064 A	10/1993	Baum et al.	5,993,402 A	11/1999	Sauer et al.
5,257,933 A	11/1993	Jousson	6,030,215 A	2/2000	Ellion et al.
D341,943 S	12/1993	Si-Hoe	6,039,180 A	3/2000	Grant
5,267,586 A	12/1993	Jankavaara	D425,615 S	5/2000	Bachman et al.
5,269,684 A	12/1993	Fischer	D425,981 S	5/2000	Bachman et al.
5,281,137 A	1/1994	Jousson	6,056,710 A	5/2000	Bachman et al.
5,281,139 A	1/1994	Frank et al.	D426,633 S	6/2000	Bachman et al.
5,282,745 A	2/1994	Wiltrout et al.	6,089,865 A	7/2000	Edgar
5,286,192 A	2/1994	Dixon	6,124,699 A	9/2000	Suzuki et al.
5,286,201 A	2/1994	Yu	D434,500 S	11/2000	Pollock et al.
5,297,962 A	3/1994	O'Connor et al.	6,159,006 A	12/2000	Cook et al.
D346,212 S	4/1994	Hosl	6,164,967 A	12/2000	Sale et al.
5,302,123 A	4/1994	Bechard	D435,905 S	1/2001	Bachman et al.
			6,193,512 B1	2/2001	Wallace
			6,193,932 B1	2/2001	Wu et al.
			6,199,239 B1	3/2001	Dickerson
			D439,781 S	4/2001	Spore



(56)

References Cited

U.S. PATENT DOCUMENTS

6,217,835 B1 4/2001 Riley et al.  
 D441,861 S 5/2001 Hafliger  
 6,233,773 B1 5/2001 Karge et al.  
 6,234,205 B1 5/2001 D'Amelio et al.  
 6,237,178 B1 5/2001 Krammer et al.  
 6,247,929 B1 6/2001 Bachman et al.  
 6,293,792 B1 9/2001 Hanson  
 D449,884 S 10/2001 Tobin et al.  
 6,363,565 B1 4/2002 Paffrath  
 6,468,482 B1 10/2002 Frieze et al.  
 6,475,173 B1 11/2002 Bachman et al.  
 6,485,451 B1 11/2002 Roberts et al.  
 6,497,572 B2 12/2002 Hood et al.  
 6,502,584 B1 1/2003 Fordham  
 D470,660 S 2/2003 Schaber  
 6,558,344 B2 5/2003 McKinnon et al.  
 6,561,808 B2 5/2003 Neuberger et al.  
 D475,346 S 6/2003 McCurrach et al.  
 6,589,477 B1 7/2003 Frieze et al.  
 6,602,071 B1 8/2003 Ellion et al.  
 6,632,091 B1 10/2003 Cise et al.  
 D482,451 S 11/2003 Page et al.  
 6,640,999 B2 11/2003 Peterson  
 6,647,577 B2 11/2003 Tam  
 6,659,674 B2 12/2003 Carlucci et al.  
 6,669,059 B2 12/2003 Mehta  
 D486,573 S \* 2/2004 Callaghan et al. .... D24/111  
 6,689,078 B1 2/2004 Rehkemper et al.  
 6,699,208 B2 3/2004 Bachman et al.  
 6,719,561 B2 4/2004 Gugel et al.  
 D489,183 S 5/2004 Akahori et al.  
 6,739,782 B1 5/2004 Rehkemper et al.  
 6,740,053 B2 5/2004 Kaplowitz  
 D490,899 S 6/2004 Gagnon  
 D491,728 S 6/2004 Jimenez  
 D492,996 S 7/2004 Rehkemper et al.  
 6,761,324 B2 7/2004 Chang  
 6,766,549 B2 7/2004 Klupt  
 D495,142 S 8/2004 Berde  
 D495,143 S 8/2004 Berde  
 6,779,216 B2 8/2004 Davies et al.  
 6,783,004 B1 8/2004 Rinner  
 6,783,505 B1 8/2004 Lai  
 6,796,796 B2 9/2004 Segal  
 6,814,259 B1 11/2004 Foster et al.  
 D499,885 S 12/2004 Xi  
 6,835,181 B2 12/2004 Hippensteel  
 6,884,069 B2 4/2005 Goldman  
 6,907,879 B2 6/2005 Drinan et al.  
 D509,585 S 9/2005 Kling et al.  
 D513,638 S 1/2006 Pan  
 7,080,980 B2 7/2006 Klupt  
 D530,010 S 10/2006 Luettgen et al.  
 7,117,555 B2 10/2006 Fattori et al.  
 D533,720 S 12/2006 Vu  
 7,147,468 B2 \* 12/2006 Snyder et al. .... 433/80  
 D538,474 S 3/2007 Sheppard et al.  
 D548,334 S 8/2007 Izumi  
 D550,097 S 9/2007 Lepoitevin  
 7,276,035 B2 10/2007 Lu  
 7,314,456 B2 1/2008 Shaw  
 D565,175 S 3/2008 Boyd et al.  
 7,344,510 B1 3/2008 Yande  
 7,367,803 B2 5/2008 Egeresi  
 7,455,521 B2 11/2008 Fishburne, Jr.  
 7,469,440 B2 12/2008 Boland et al.  
 7,500,584 B2 3/2009 Schutz  
 D601,697 S 10/2009 Sobiech et al.  
 D603,708 S 11/2009 Handy  
 7,670,141 B2 \* 3/2010 Thomas et al. .... 433/80  
 7,677,888 B1 3/2010 Halm  
 7,814,585 B1 10/2010 Reich  
 D629,884 S \* 12/2010 Stephens ..... D24/108  
 7,862,536 B2 1/2011 Chen et al.  
 7,878,403 B2 2/2011 Hennick et al.

7,959,597 B2 6/2011 Baker et al.  
 8,113,832 B2 \* 2/2012 Snyder et al. .... 433/80  
 D670,373 S \* 11/2012 Taylor et al. .... D24/108  
 8,403,665 B2 3/2013 Thomas et al.  
 8,408,483 B2 4/2013 Boyd et al.  
 2003/0062367 A1 4/2003 Robinson et al.  
 2003/0098249 A1 5/2003 Rollock  
 2003/0204155 A1 10/2003 Egeresi  
 2003/0213075 A1 11/2003 Hui et al.  
 2004/0045107 A1 3/2004 Egeresi  
 2004/0076921 A1 4/2004 Gofman et al.  
 2004/0122377 A1 6/2004 Fischer et al.  
 2004/0209222 A1 10/2004 Snyder et al.  
 2005/0049620 A1 3/2005 Chang  
 2005/0101894 A1 5/2005 Hippensteel  
 2005/0271531 A1 12/2005 Brown et al.  
 2006/0008373 A1 1/2006 Schutz  
 2006/0021165 A1 2/2006 Boland et al.  
 2006/0026784 A1 2/2006 Moskovich et al.  
 2006/0057539 A1 3/2006 Sodo  
 2006/0078844 A1 4/2006 Goldman et al.  
 2006/0079818 A1 4/2006 Yande  
 2006/0253087 A1 11/2006 Vlodayer et al.  
 2007/0082316 A1 4/2007 Zhadanov et al.  
 2007/0113360 A1 5/2007 Tsai  
 2007/0202459 A1 8/2007 Boyd et al.  
 2007/0203439 A1 8/2007 Boyd et al.  
 2007/0254260 A1 11/2007 Alden  
 2008/0008979 A1 1/2008 Thomas et al.  
 2008/0294124 A1 11/2008 Mehta  
 2009/0070949 A1 3/2009 Sagel et al.  
 2009/0082706 A1 3/2009 Shaw  
 2009/0124945 A1 5/2009 Reich et al.  
 2009/0163839 A1 6/2009 Alexander  
 2009/0234325 A1 9/2009 Rozenberg et al.  
 2009/0281454 A1 11/2009 Baker et al.  
 2010/0015566 A1 1/2010 Shaw  
 2010/0190132 A1 7/2010 Taylor  
 2010/0239998 A1 9/2010 Snyder et al.  
 2010/0261134 A1 10/2010 Boyd et al.  
 2010/0261137 A1 10/2010 Boyd et al.  
 2010/0326536 A1 12/2010 Nan  
 2010/0330527 A1 12/2010 Boyd et al.  
 2011/0027749 A1 2/2011 Syed  
 2011/0097683 A1 4/2011 Boyd et al.  
 2011/0139826 A1 6/2011 Hair et al.  
 2011/0144588 A1 \* 6/2011 Taylor et al. .... 604/151  
 2011/0184341 A1 7/2011 Baker et al.  
 2012/0021374 A1 1/2012 Cacka et al.  
 2012/0045730 A1 2/2012 Snyder et al.  
 2012/0077145 A1 3/2012 Tsurukawa  
 2012/0141952 A1 6/2012 Snyder et al.  
 2012/0277677 A1 \* 11/2012 Taylor et al. .... 604/151  
 2012/0277678 A1 \* 11/2012 Taylor et al. .... 604/153  
 2012/0295220 A1 11/2012 Thomas et al.

FOREIGN PATENT DOCUMENTS

DE 1466963 5/1969  
 DE 2409752 9/1975  
 DE 2545936 4/1977  
 DE 2910982 2/1980  
 DE 29602605 4/1996  
 EP 0023672 7/1980  
 FR 2556954 6/1985  
 FR 2654627 5/1991  
 GB 881807 10/1958  
 GB 1182031 2/1970  
 GB 2018605 10/1979  
 JP 2-134150 4/1990  
 JP 2009-39455 2/2009  
 WO WO95/16404 6/1995  
 WO WO96/29044 9/1996  
 WO WO2004/021958 3/2004  
 WO WO2004/039205 5/2004  
 WO WO2005/000477 1/2005

OTHER PUBLICATIONS

(56)

**References Cited**

## OTHER PUBLICATIONS

Rabago et al., "Efficacy of Daily Hypertonic Saline Nasal Irrigation Among Patients with Sinusitis: A Randomized Controlled Trial," *The Journal of Family Practice*, vol. 51, No. 12, pp. 1049-1055, Dec. 2002.

Pepsin et al., "Saline Nasal Irrigation," *Canadian Family Physician*, vol. 49, pp. 168-173, Feb. 2003.

Website: <http://www.products.consumerguide.com/cp/family/review/index.dfm/id/18742>, 2 pages, at least as early as Jun. 20, 2003.

Website: <http://www.racekarteng.com/images/walbroparts.gif> and <http://www.muller.net/mullermachine/docs/walbro1.html>, 4 pages, at least as early as Jun. 20, 2003.

European Search Report, EPO Application No. 07250799.9, Jul. 5, 2007.

European Search Report, EPO Application No. 07252693.2, 14 pages, Apr. 28, 2008.

Schumann et al., "Patients Insist on Antibiotics for Sinusitis? Here is a Good Reason to Say 'No'," *The Journal of Family Practice*, vol. 57, No. 7, pp. 464-468, Jul. 2008.

European Examination Report, EPO Application No. 07250799.9, Feb. 5, 2009.

Author Unknown, "NasaFlo Neti Pot," <http://www.neilmed.com/usa/nasaflo.php>, 1 page, at least as early as Dec. 9, 2009.

Author Unknown, "SinuFlo Ready Rinse," <http://www.neilmed.com/usa/sinuflo.php>, 1 page, at least as early as Dec. 9, 2009.

Author Unknown, "Sinus Rinse Nasal Wash," <http://www.neilmed.com/usa/sinusrinse.php>, 3 pages, at least as early as Dec. 9, 2009.

International Search Report, Application No. PCT/US2010/028180, 2 pages, May 18, 2010.

International Search Report, PCT/US2010/060800, 2 pages, Feb. 11, 2011.

International Search Report, PCT/US2010/060901, 2 pages, Feb. 11, 2011.

International Search Report, PCT/US2010/060880, 2 pages, Feb. 14, 2011.

International Search Report, PCT/US2010/060882, 2 pages, Feb. 16, 2011.

International Search Report, PCT/US2010/060820, 2 pages, Feb. 16, 2011.

International Search Report, PCT/US2011/052795, 10 pages, Jan. 17, 2012.

Waterpik SinuSense, Website: <http://www.insightsbyapril.com/2012/03/waterpik-natural-remedyfor-sinus.html>, retrieved on May 31, 2012.

US RE27,274, 01/1972, Mattingly (withdrawn)

\* cited by examiner

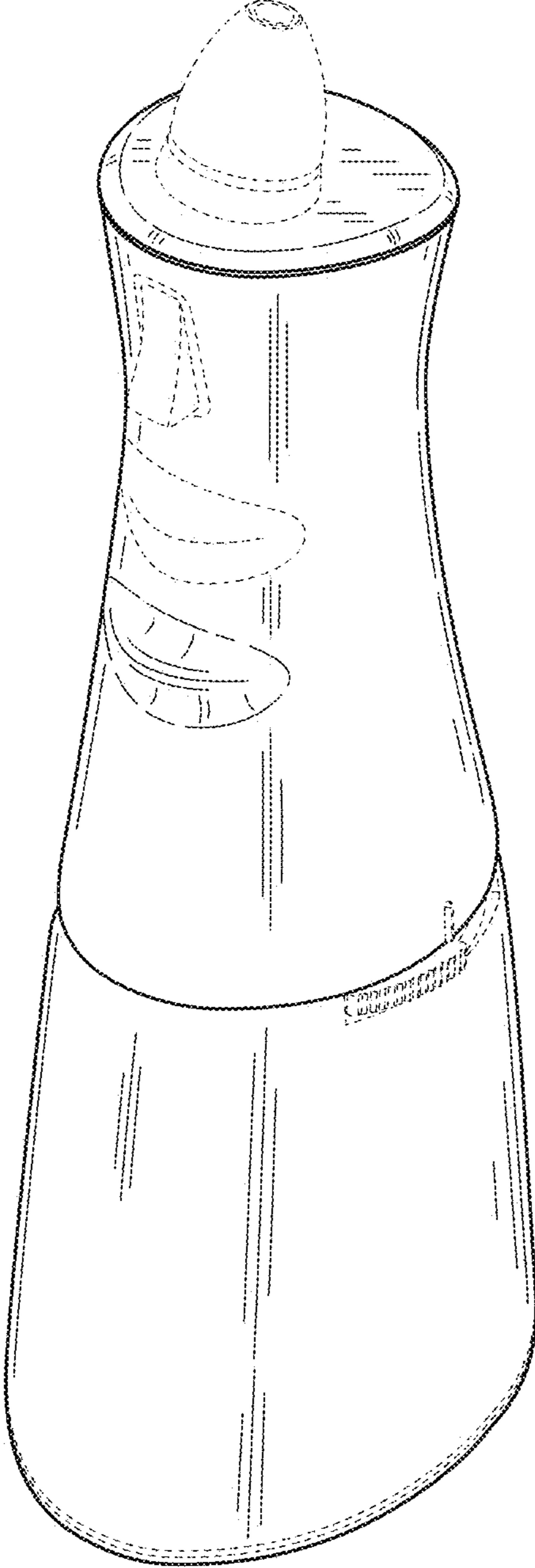

FIG.1



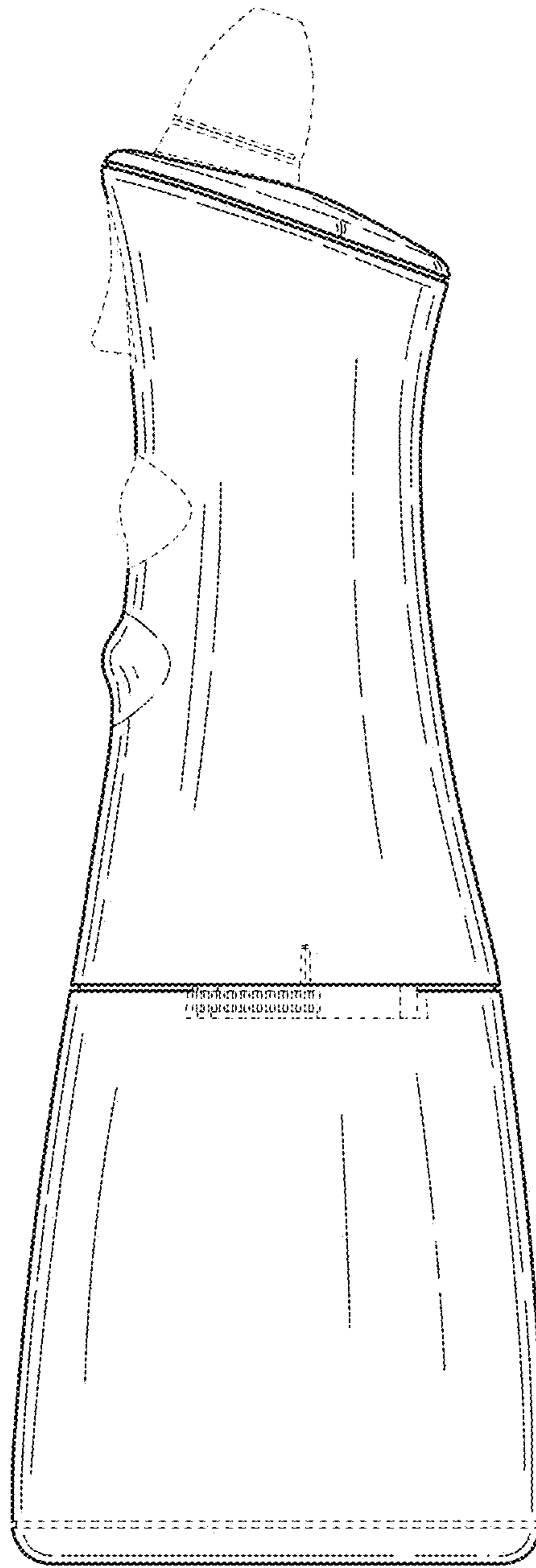

FIG.2

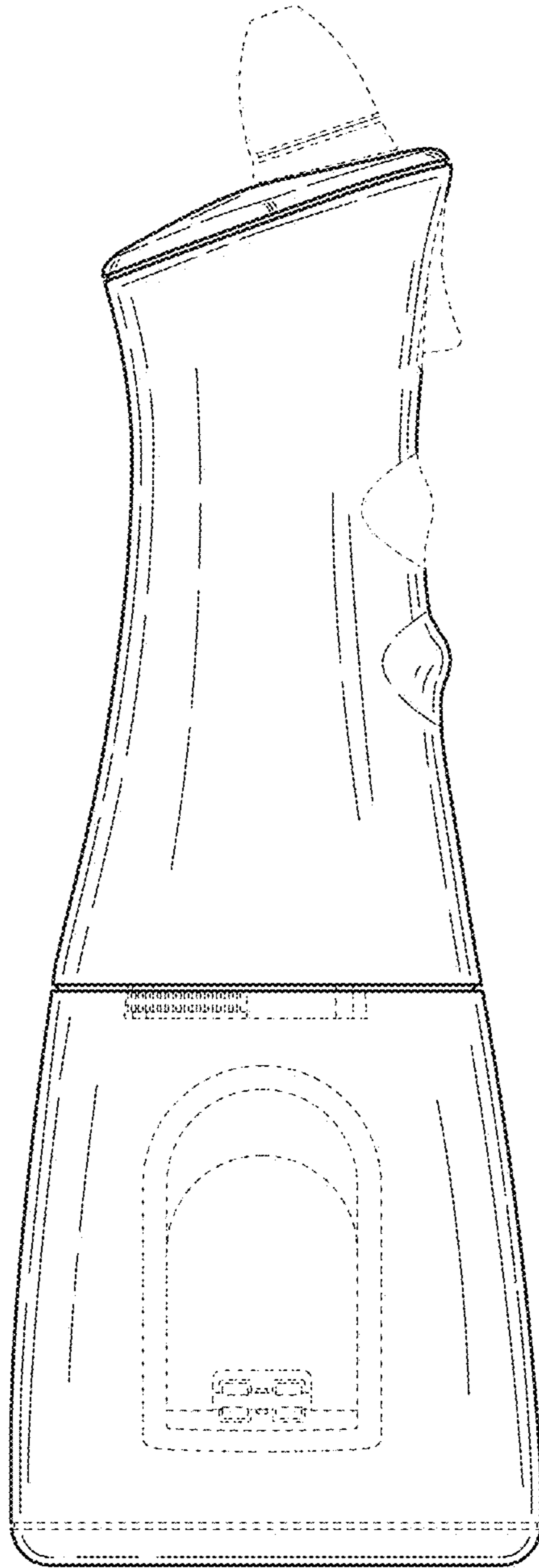

FIG. 3



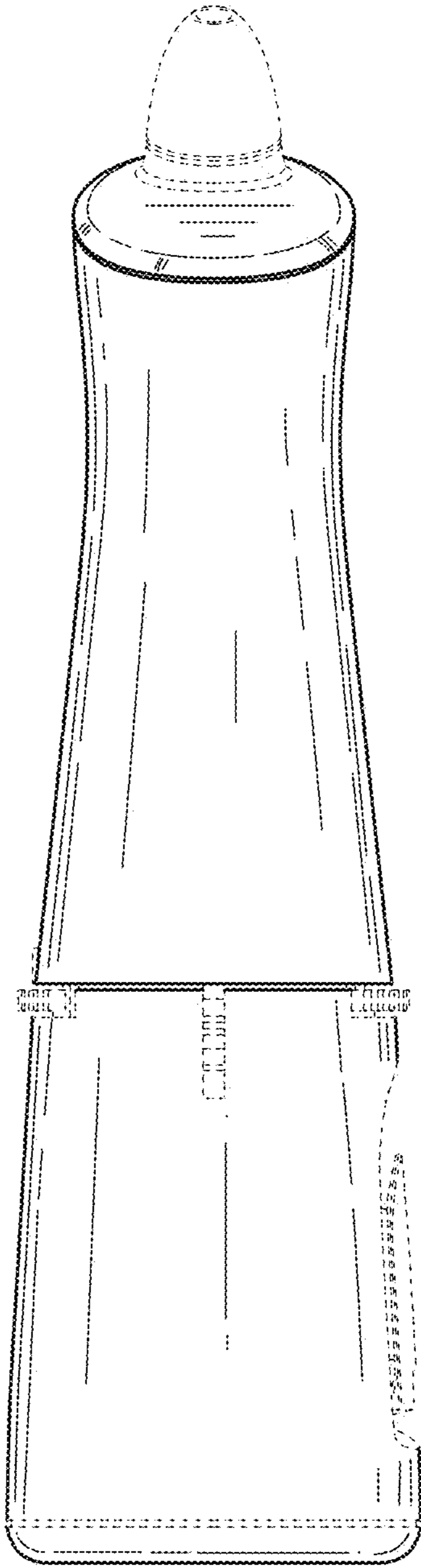

FIG.4

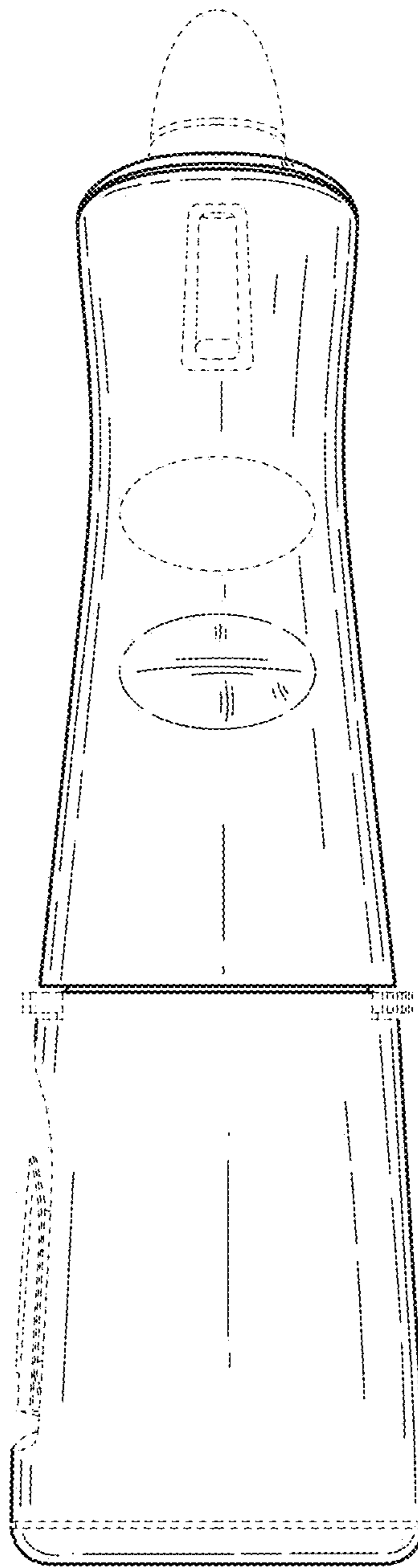

FIG.5