



US00D694186S

(12) **United States Design Patent**
Terashita et al.

(10) **Patent No.:** **US D694,186 S**

(45) **Date of Patent:** **** Nov. 26, 2013**

(54) **BRUSHLESS MOTOR**

(75) Inventors: **Shigeaki Terashita**, Kiryu (JP); **Yoji Unoki**, Kiryu (JP)

(73) Assignee: **Nidec Servo Corporation**, Gumma (JP)

(**) Term: **14 Years**

(21) Appl. No.: **29/386,029**

(22) Filed: **Feb. 24, 2011**

(30) **Foreign Application Priority Data**

Aug. 31, 2010 (JP) 2010-021046

(51) **LOC (9) Cl.** **13-01**

(52) **U.S. Cl.**
USPC **D13/112**

(58) **Field of Classification Search**
USPC D13/112, 113, 114, 120, 122, 199;
D15/3, 5, 199; 74/606 R, 609; 310/10,
310/40 R, 42, 51, 58, 71, 80, 83, 85, 89, 91,
310/109, 236, 239, 254; 318/245, 255
See application file for complete search history.

(56) **References Cited**

U.S. PATENT DOCUMENTS

D306,009 S * 2/1990 Mintz et al. D13/112
4,988,905 A * 1/1991 Tolmie, Jr. 310/68 B
D424,516 S * 5/2000 Friedrichsen D13/112
6,593,674 B2 * 7/2003 Sanchez et al. 310/89
D578,063 S * 10/2008 Lannoch D13/112
D597,943 S * 8/2009 Lin et al. D13/112
D610,987 S * 3/2010 Oohashi et al. D13/112

7,781,926 B2 * 8/2010 Schmidt et al. 310/77
D627,721 S * 11/2010 Kuraishi et al. D13/112
D634,272 S * 3/2011 Veeh D13/112

OTHER PUBLICATIONS

Minebea Motor Manufacturing Corporation, "Hybrid Stepping Motors", http://www.eminebea.com/content/html/jp/hybrid_list/custom.shtml, Jul. 26, 2010, rev. 2.

Nidec-servo Corp., "KT35 series TRISYN", http://catalog.nidec-servo.com/digital/general/c_ste/3hbkt.html, Nov. 20, 2008.

JPO Design Section published literature No. HC18016513, Apr. 20, 2006.

* cited by examiner

Primary Examiner — Derrick Holland

(74) *Attorney, Agent, or Firm* — Keating & Bennett, LLP

(57) **CLAIM**

The ornamental design for a brushless motor, as shown and described.

DESCRIPTION

FIG. 1 is a front elevation view of a brushless motor according to our new design;

FIG. 2 is a rear elevation view thereof;

FIG. 3 is a right side elevation view thereof;

FIG. 4 is a left side elevation view thereof;

FIG. 5 is a top plan view thereof;

FIG. 6 is a bottom plan view thereof; and,

FIG. 7 is a perspective view thereof.

The broken lines shown represent unclaimed subject matter and form no part of the claimed design.

1 Claim, 7 Drawing Sheets

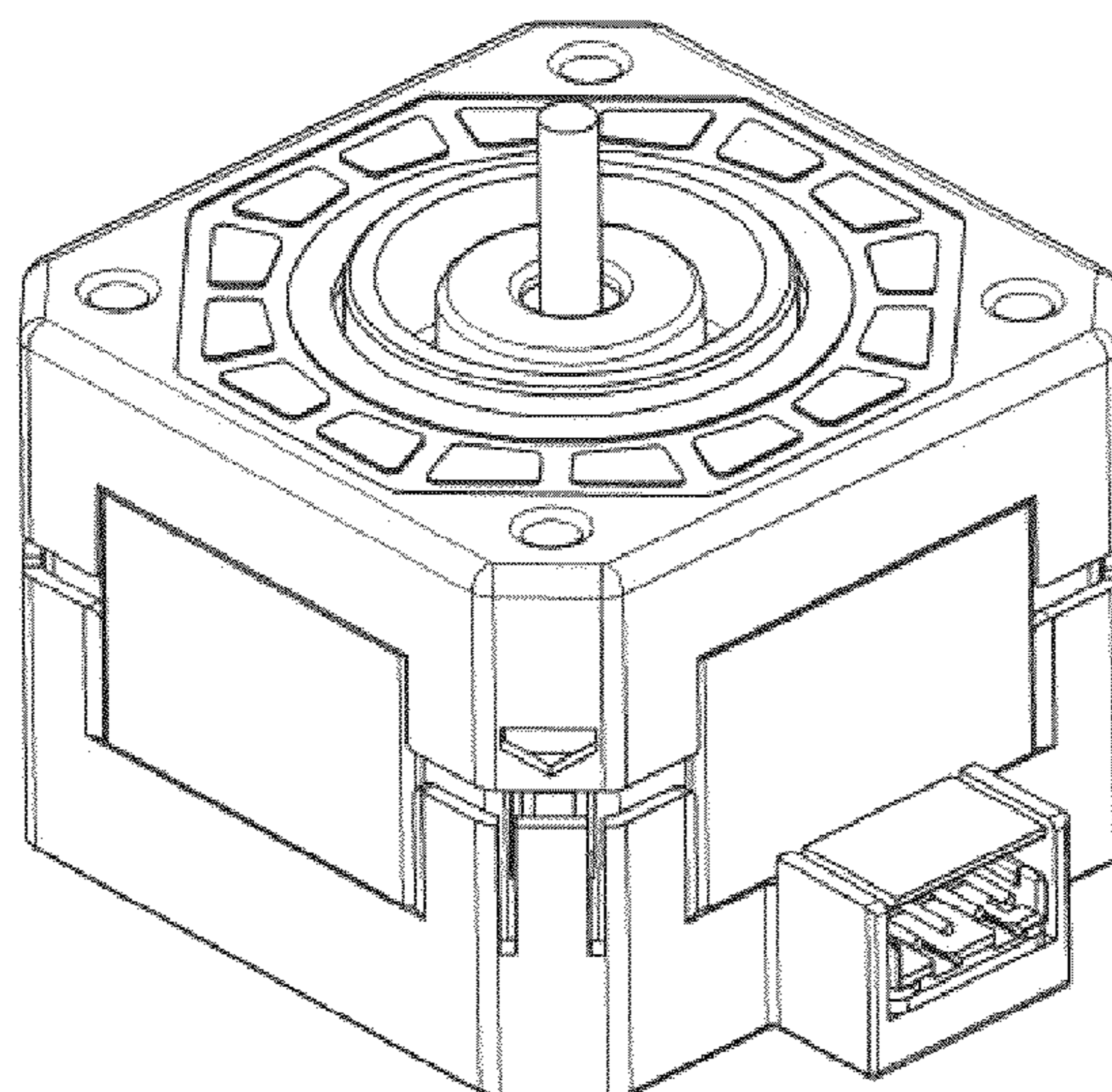

FIG. 1

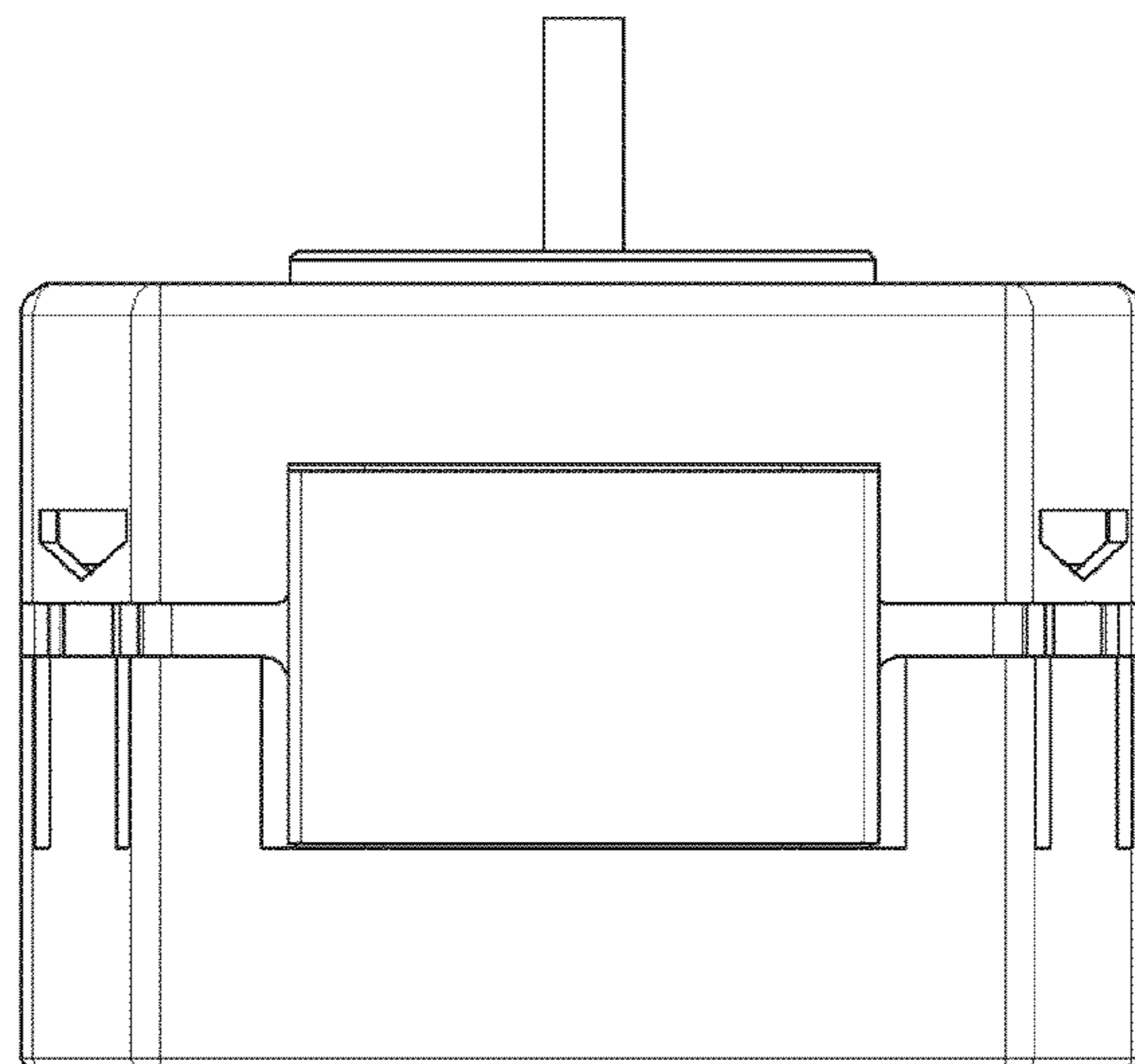

FIG. 2

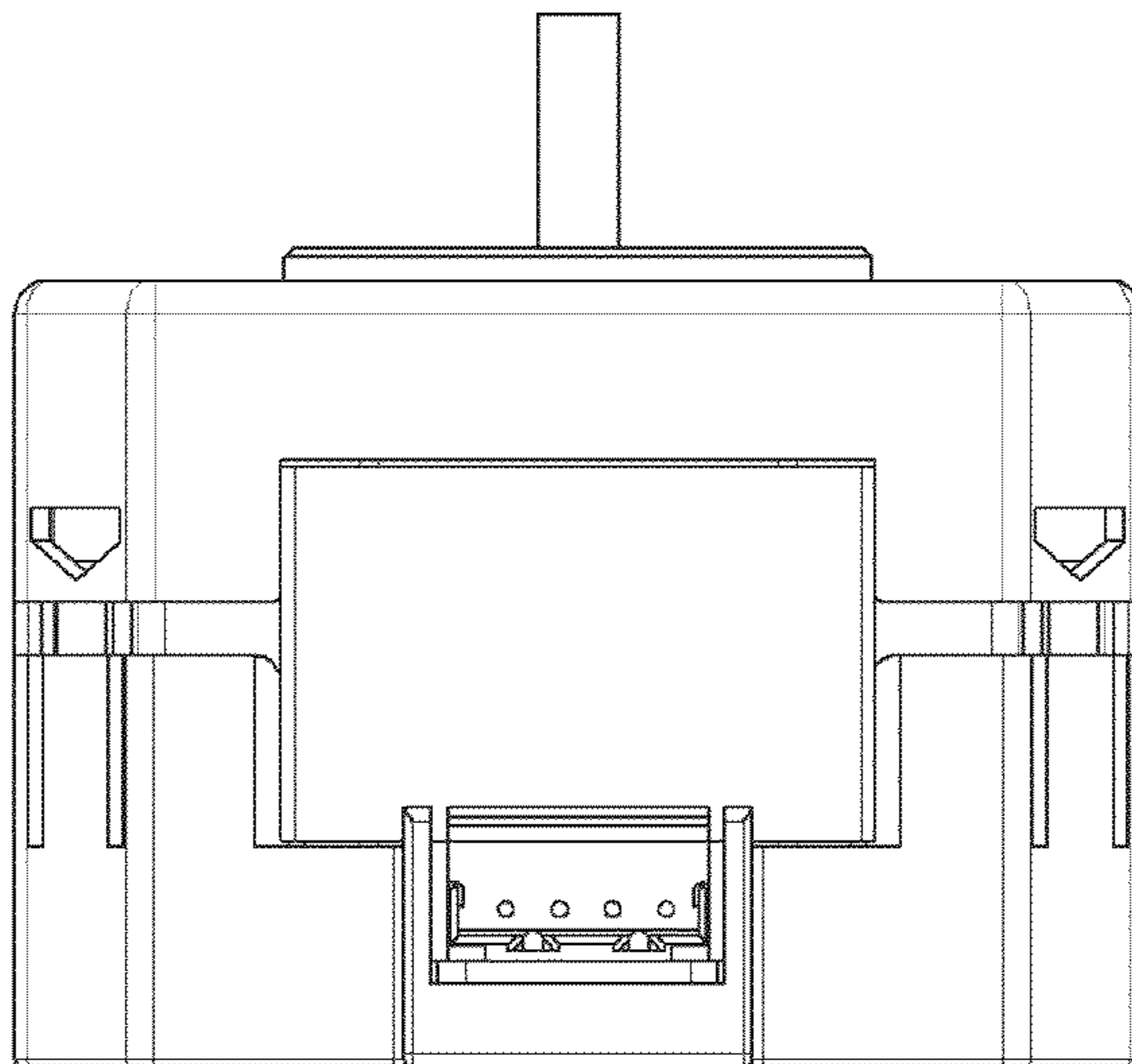

FIG. 3

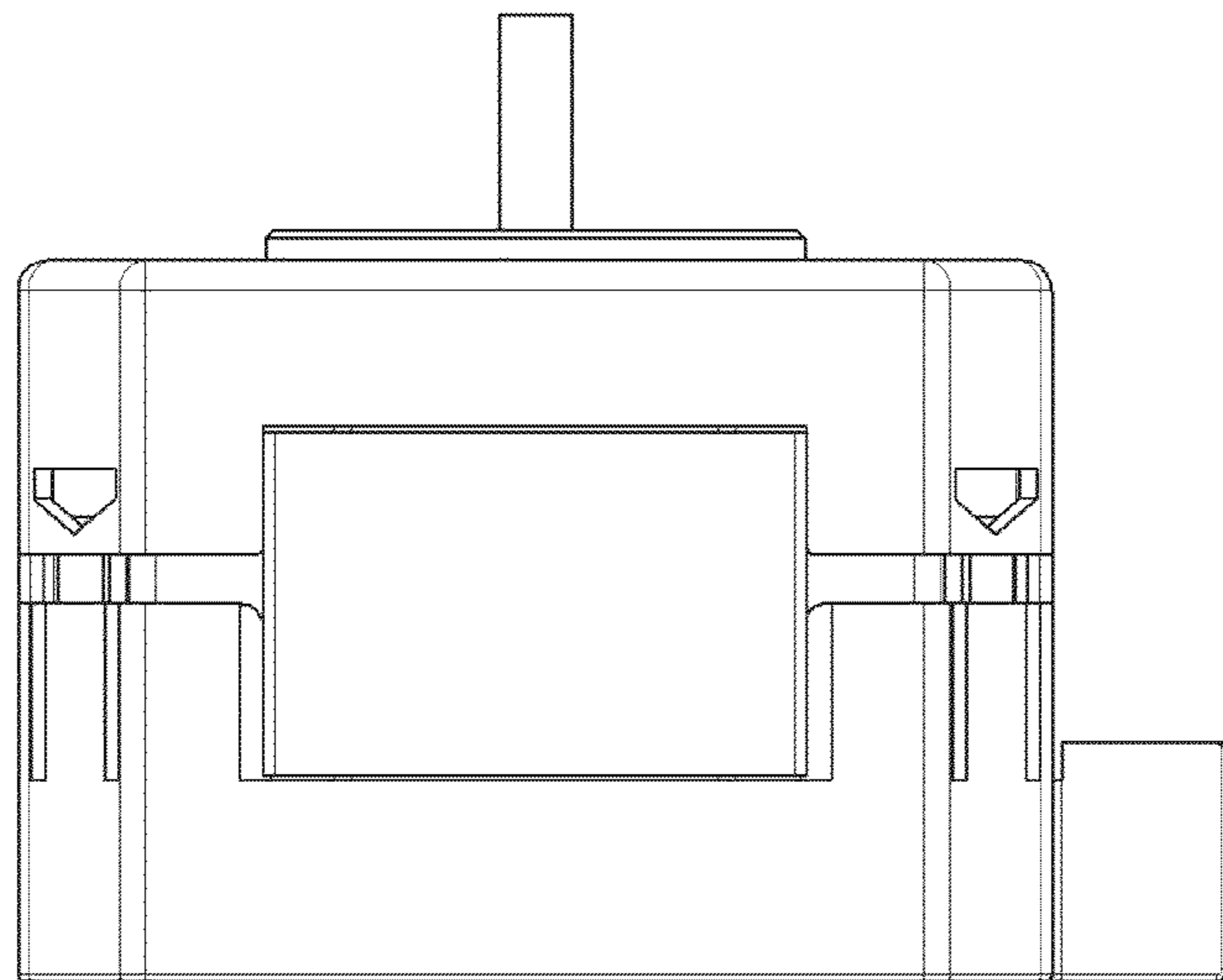

FIG. 4

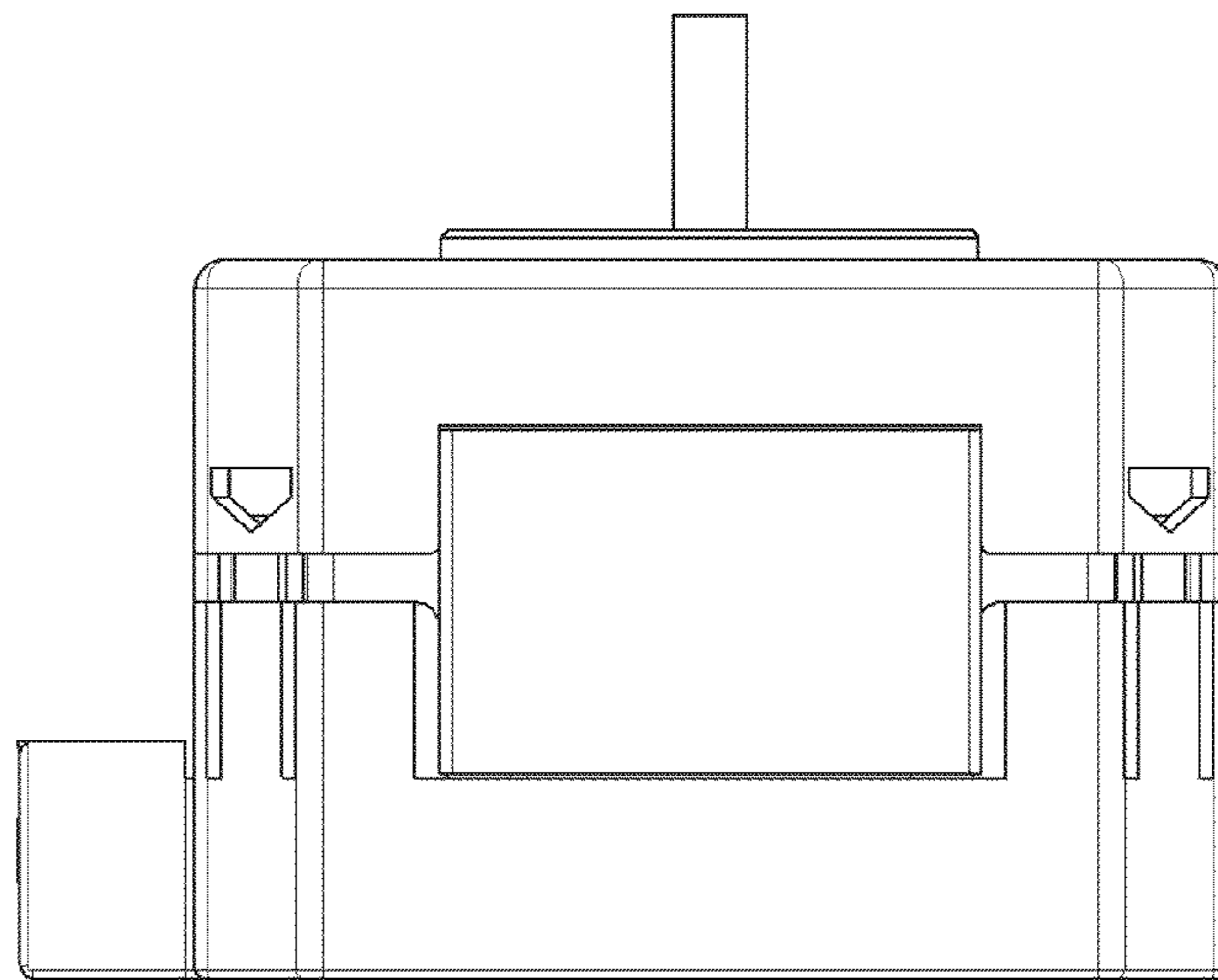

FIG. 5

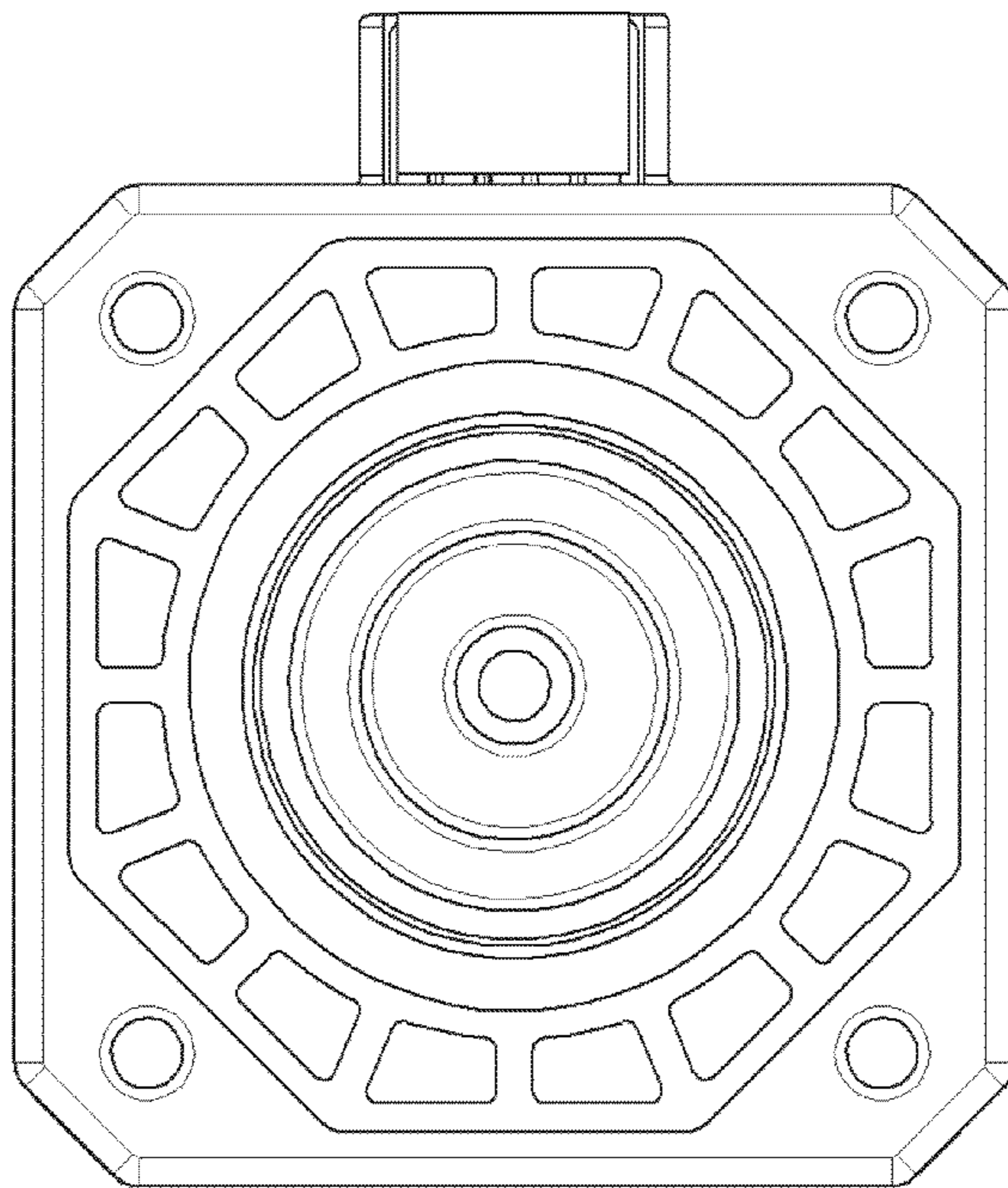

FIG. 6

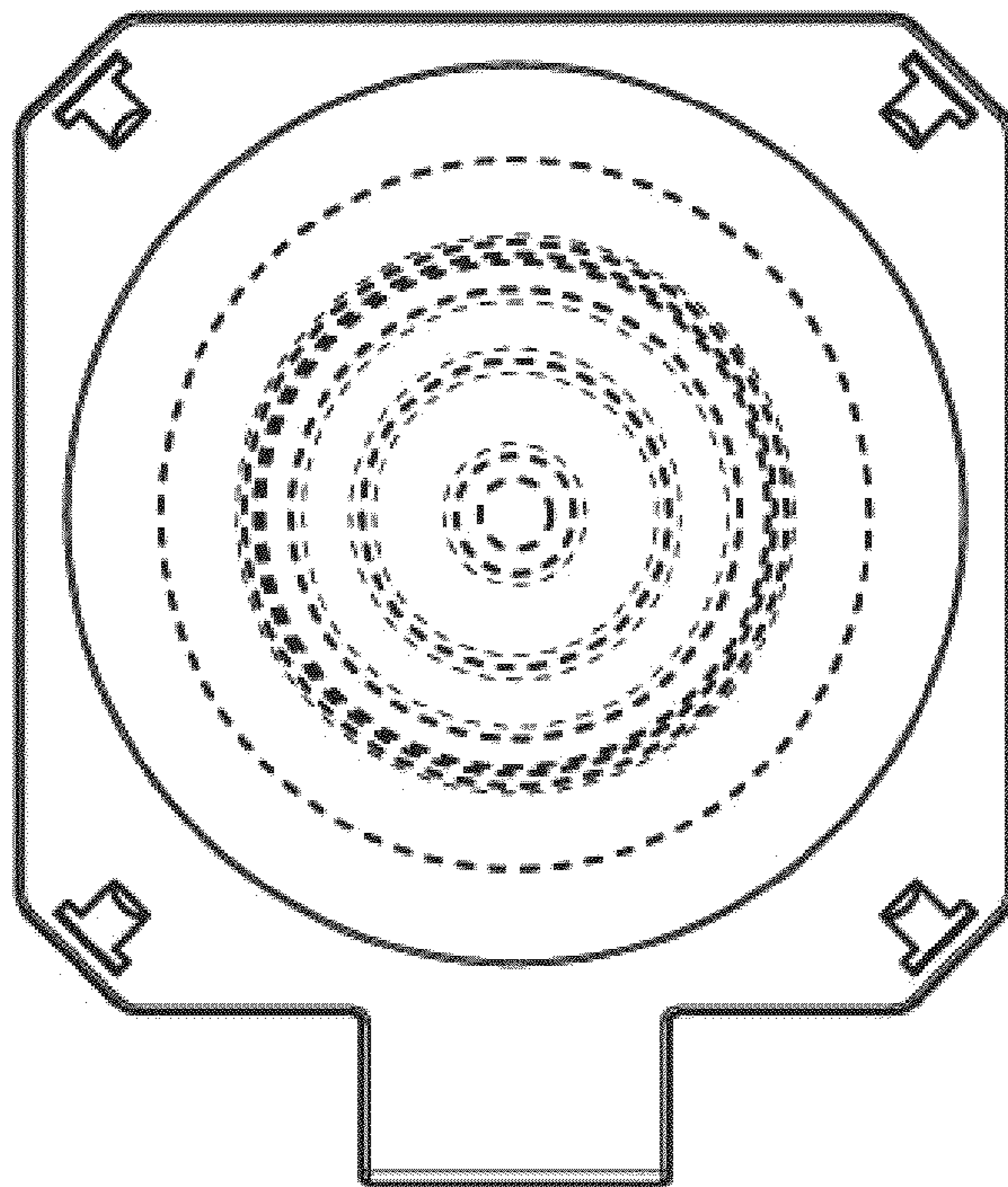

FIG. 7

