



US00D693376S

(12) **United States Design Patent**
Chlystek et al.

(10) **Patent No.:** **US D693,376 S**

(45) **Date of Patent:** **** Nov. 12, 2013**

(54) **COMBINED TRACTOR FRONT WINDOW
AND EXHAUST**

(56) **References Cited**

U.S. PATENT DOCUMENTS

(75) Inventors: **Thomas Chlystek**, Lyons, IL (US);
William Schroeder, Downers Grove, IL
(US); **Carl J. Hagele**, The Villages, IL
(US); **Richard Hagele**, legal
representative, The Villages, FL (US);
Aaron Richard, Berwyn, IL (US);
Matthew Polk, Palatine, IL (US);
Janusz Matus, Indianhead Park, IL
(US); **Daniel Morey**, Mundelein, IL
(US); **Dayal Patel**, Arlington Heights, IL
(US)

D247,624	S	*	3/1978	Emundts et al.	D15/23
D256,017	S	*	7/1980	Emundts et al.	D15/23
D274,524	S	*	7/1984	Koval et al.	D15/23
D355,423	S	*	2/1995	Woods et al.	D15/23
D498,245	S	*	11/2004	Kuwae et al.	D15/23
D519,130	S	*	4/2006	Higashikawa et al.	D15/23
D519,131	S	*	4/2006	Kuwae et al.	D15/23
D527,026	S	*	8/2006	Kuwae et al.	D15/23
D533,569	S	*	12/2006	Mursch	D15/28
D534,927	S	*	1/2007	Mursch	D15/28
D555,674	S	*	11/2007	Kuwae et al.	D15/23
D564,544	S	*	3/2008	Higashikawa et al.	D15/23
D572,642	S	*	7/2008	Steckling et al.	D12/182
D602,047	S	*	10/2009	Kushita et al.	D15/23
D603,881	S	*	11/2009	Tamplain et al.	D15/30
D605,207	S	*	12/2009	Menges et al.	D15/30
D607,388	S	*	1/2010	Mahoney	D12/182
D613,776	S	*	4/2010	Bianco et al.	D15/33
D613,777	S	*	4/2010	Bianco et al.	D15/33
D632,704	S	*	2/2011	Seidel et al.	D15/28
D641,027	S	*	7/2011	Kawashiri et al.	D15/23

(73) Assignee: **CNH America LLC**, New Holland, PA
(US)

(**) Term: **14 Years**

* cited by examiner

(21) Appl. No.: **29/411,605**

Primary Examiner — Mark Goodwin

(22) Filed: **Jan. 24, 2012**

(74) *Attorney, Agent, or Firm* — Sue C. Watson

Related U.S. Application Data

(63) Continuation of application No. 29/391,533, filed on
May 10, 2011, now Pat. No. Des. 655,318.

(51) **LOC (9) Cl.** **15-03**

(52) **U.S. Cl.**
USPC **D15/28**

(58) **Field of Classification Search**
USPC D15/10, 11, 13–17, 28, 22–26, 31;
D12/173; 56/13.3, 13.4, 15.8, 15.9,
56/320.1; 180/89.1, 89.12, 900, 69.2,
180/68.1, 69.1

See application file for complete search history.

(57) **CLAIM**

We claim the ornamental design for a combined tractor front
window and exhaust, as shown and described.

DESCRIPTION

FIG. 1 is a perspective view of a combined tractor front
window and exhaust showing our new design, the broken line
showing the tractor in all the figures is for environmental
purposes only and forms no part of the claimed design;
FIG. 2 is a front view thereof;
FIG. 3 is a rear view thereof;
FIG. 4 is a right side view thereof;
FIG. 5 is a left side view thereof;
FIG. 6 is a top plan view thereof; and,
FIG. 7 is a bottom plan view thereof.

1 Claim, 7 Drawing Sheets

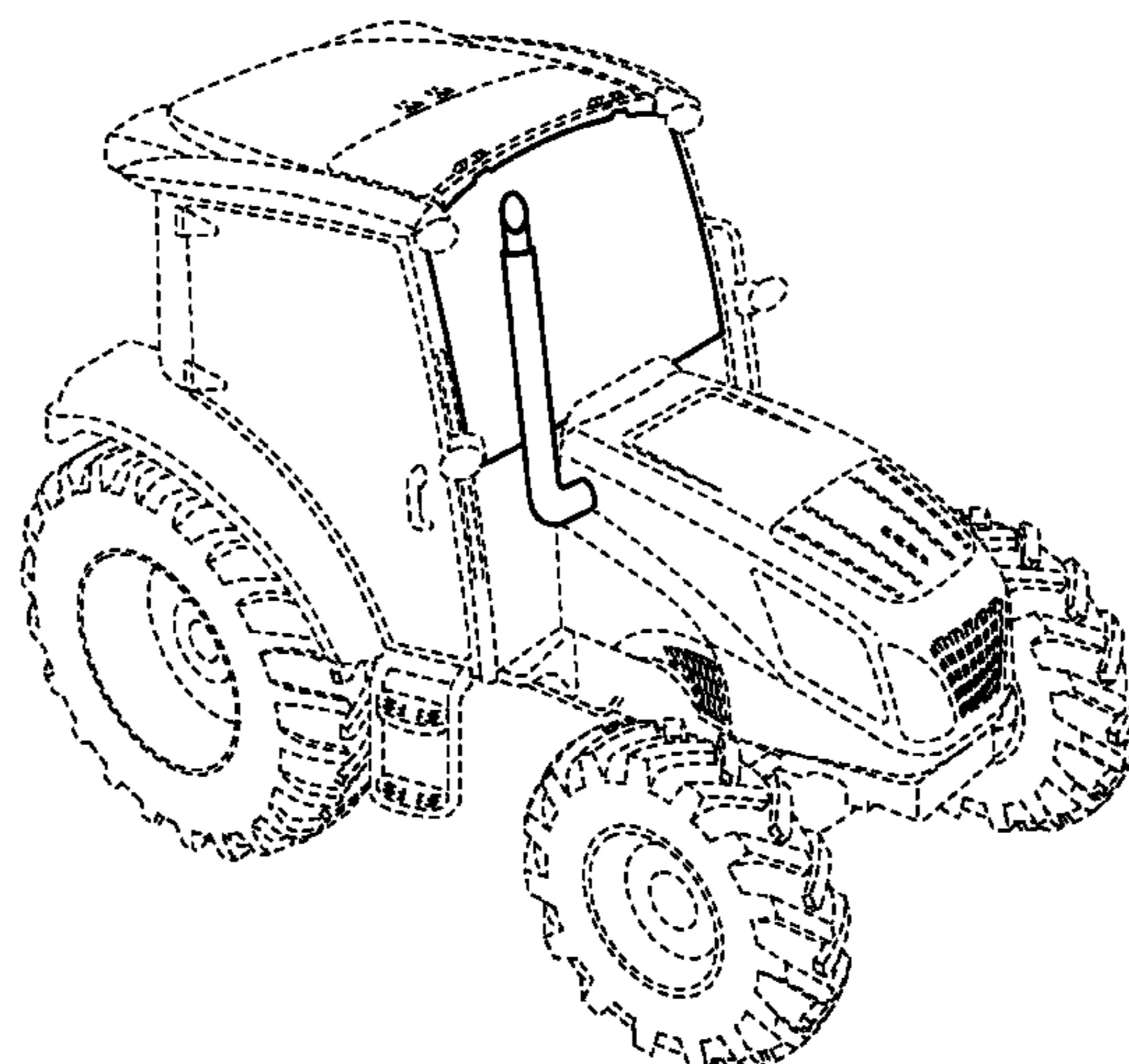

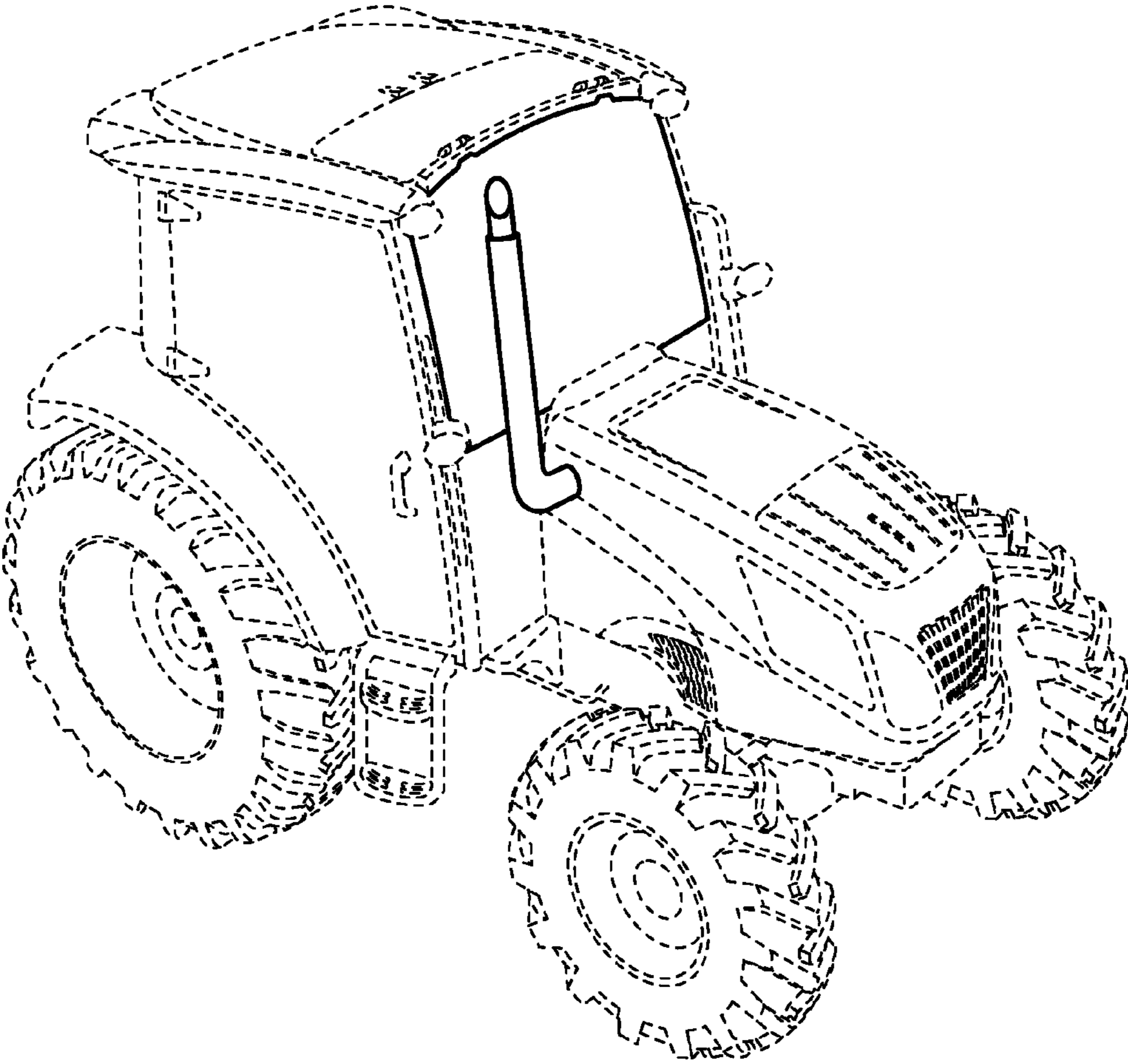

FIG. 1

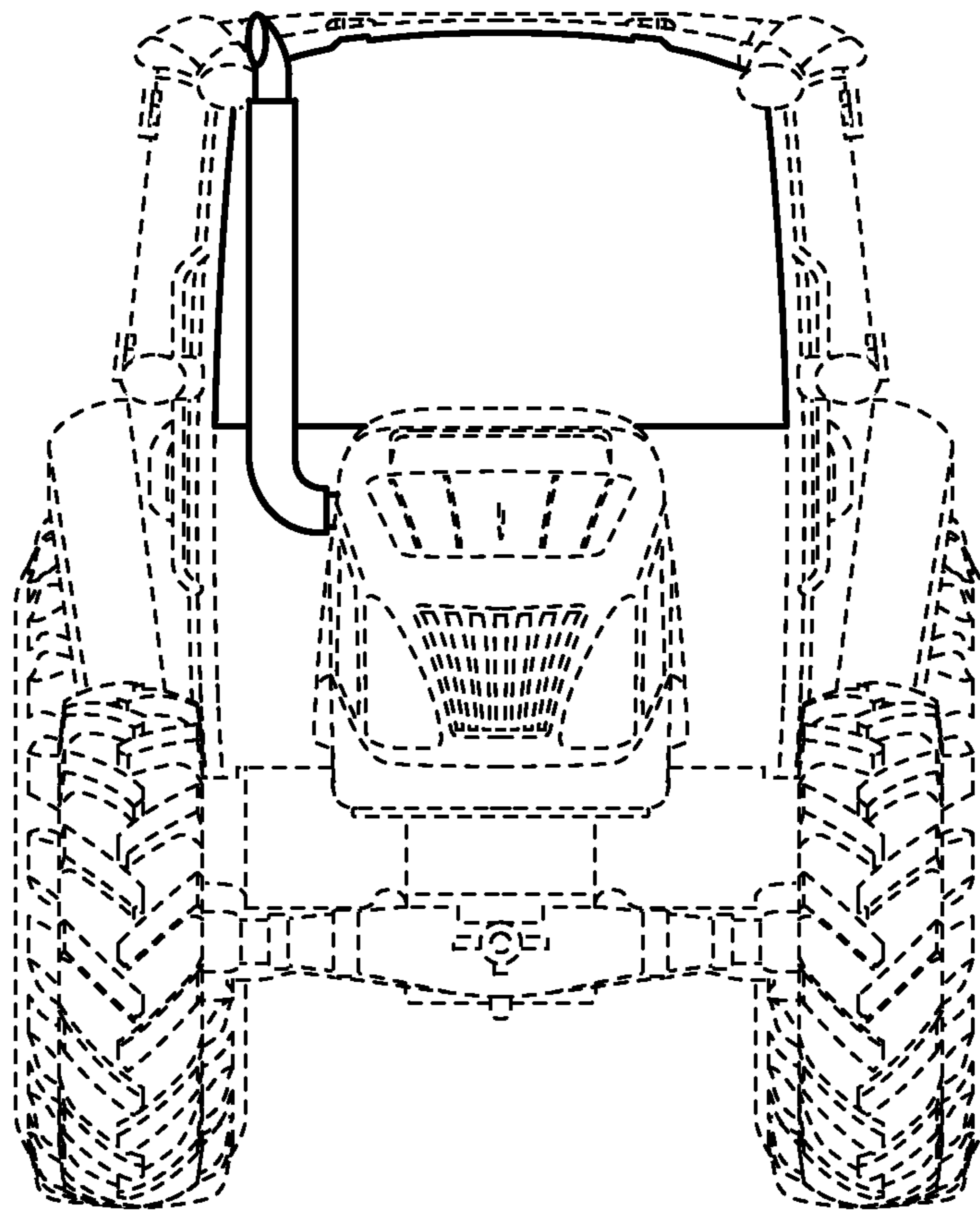

FIG. 2

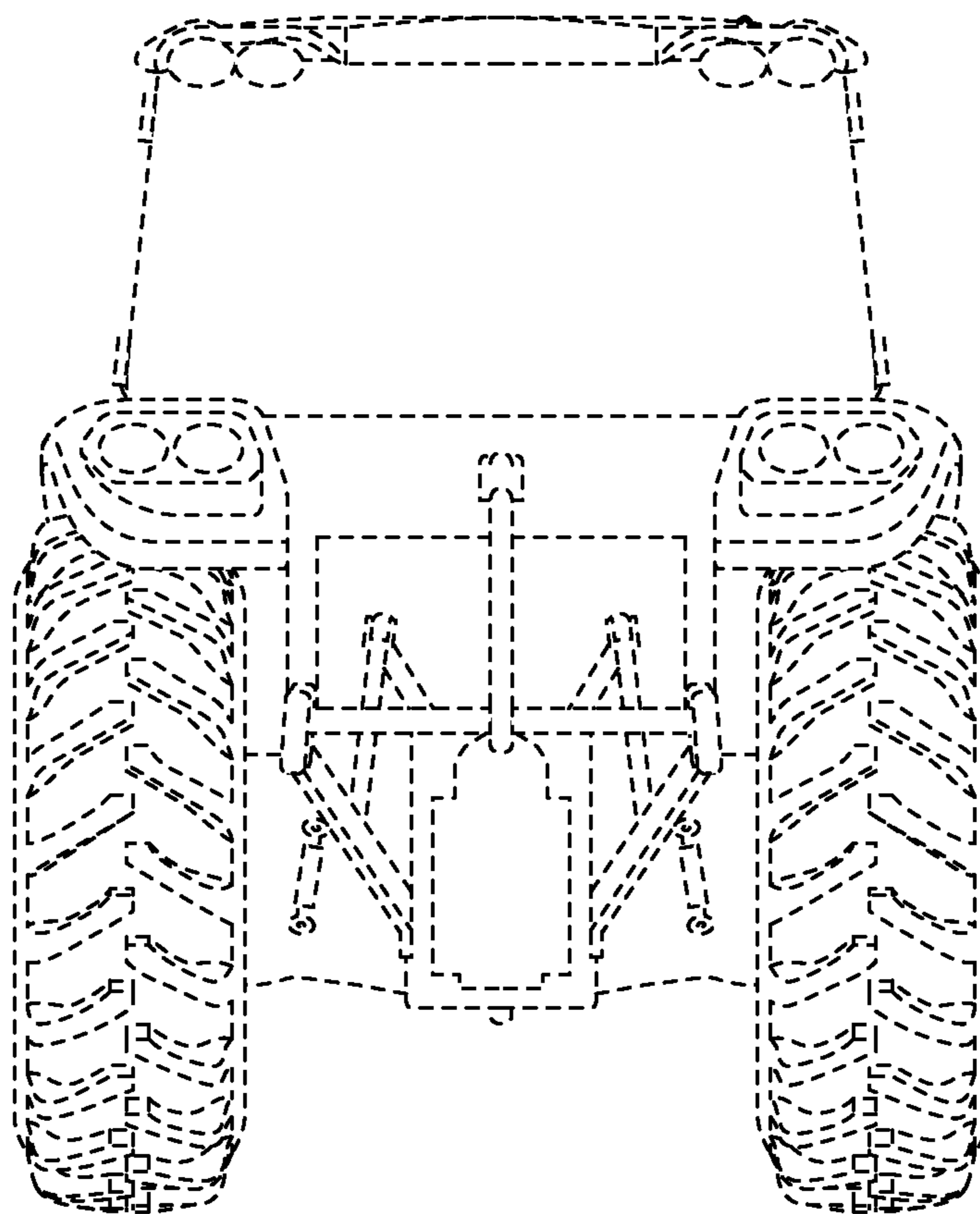

FIG. 3

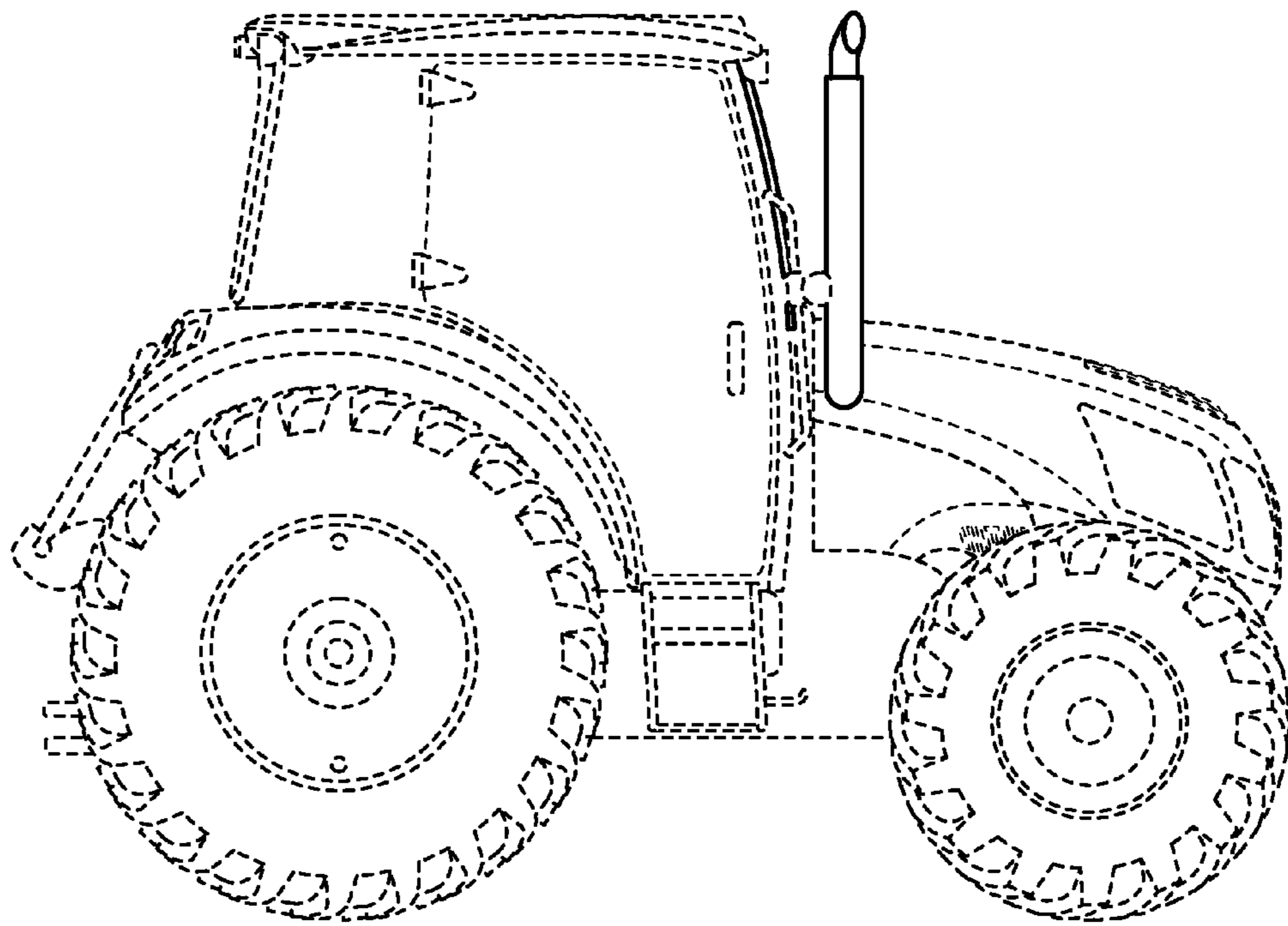

FIG. 4

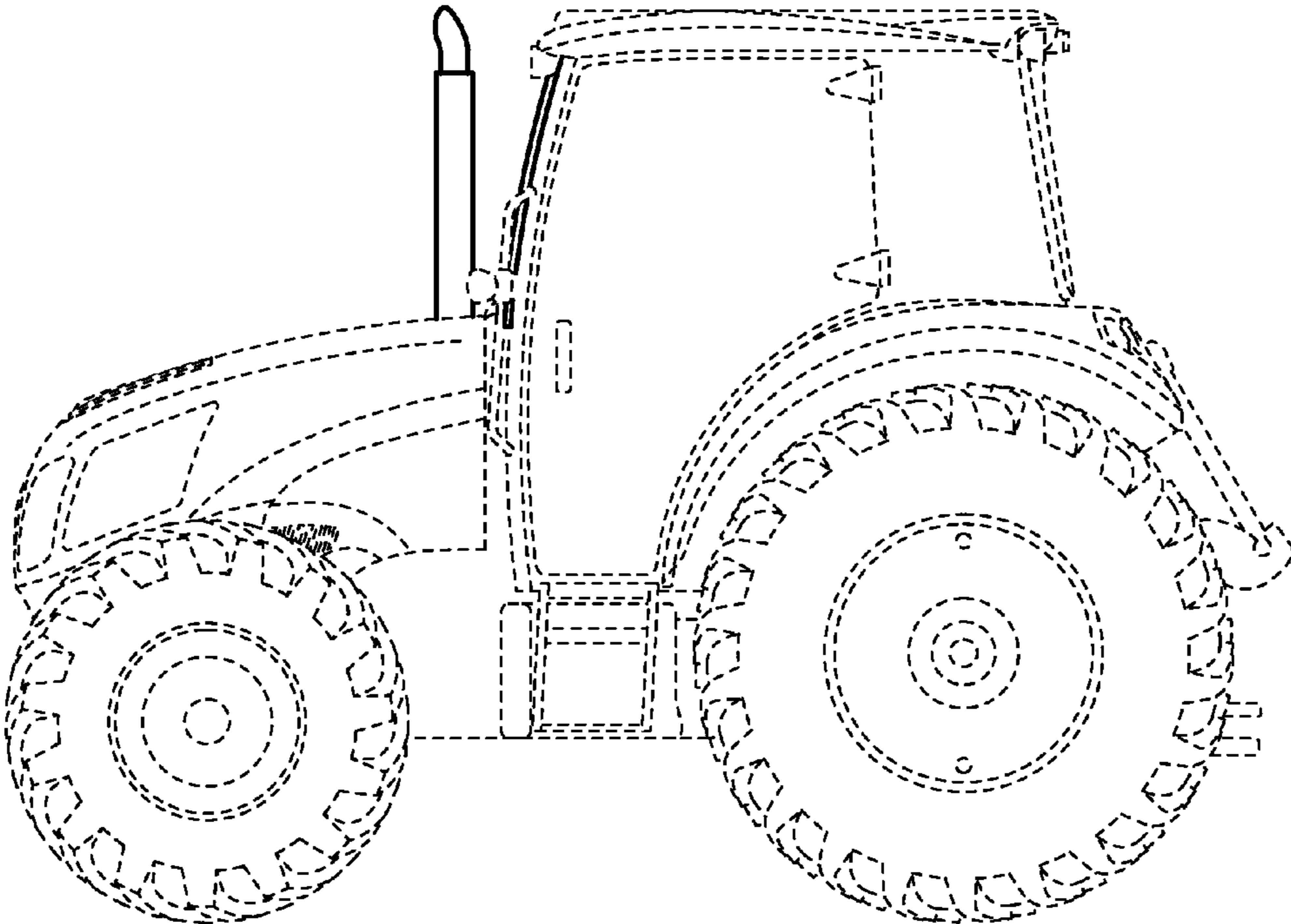

FIG. 5

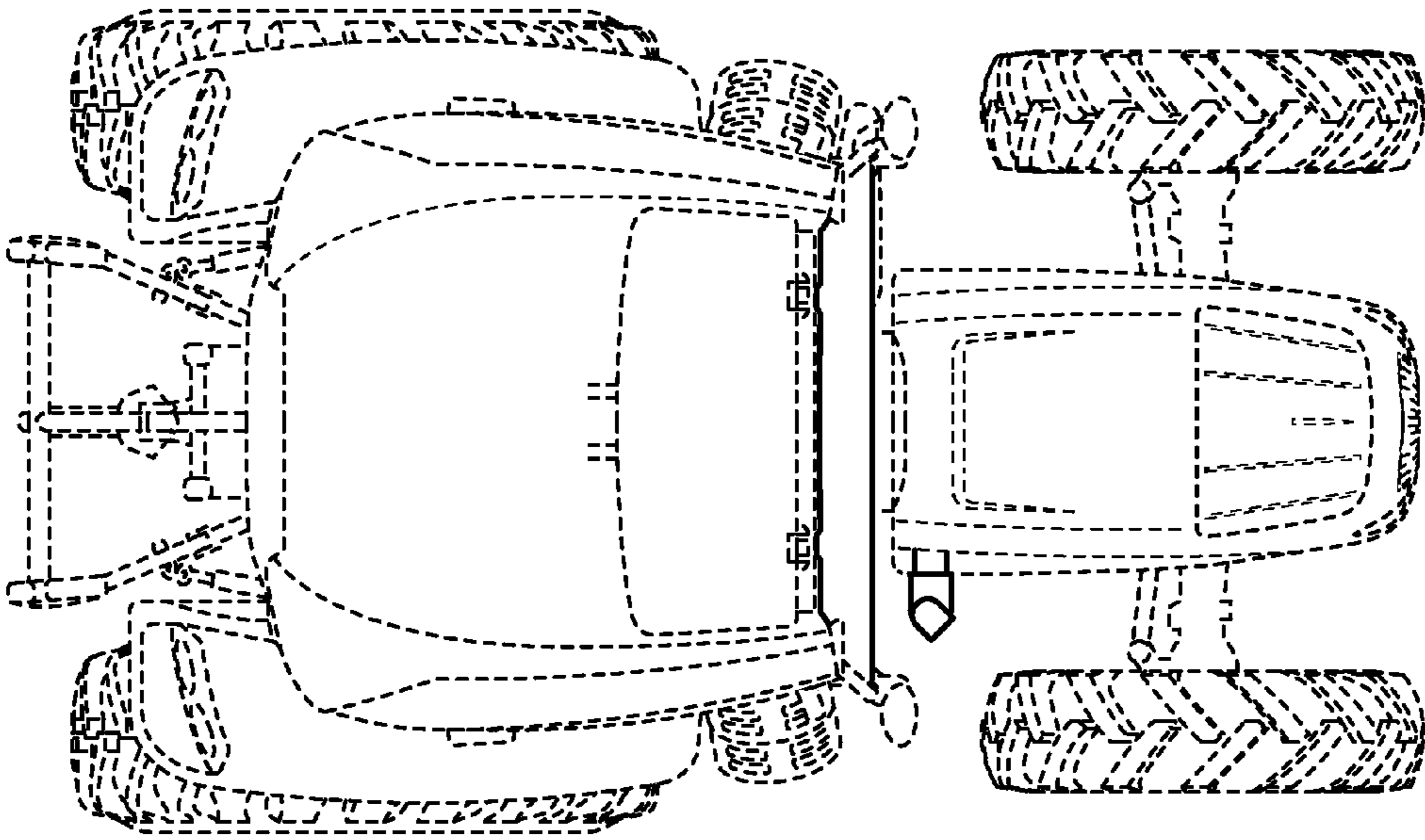

FIG. 6

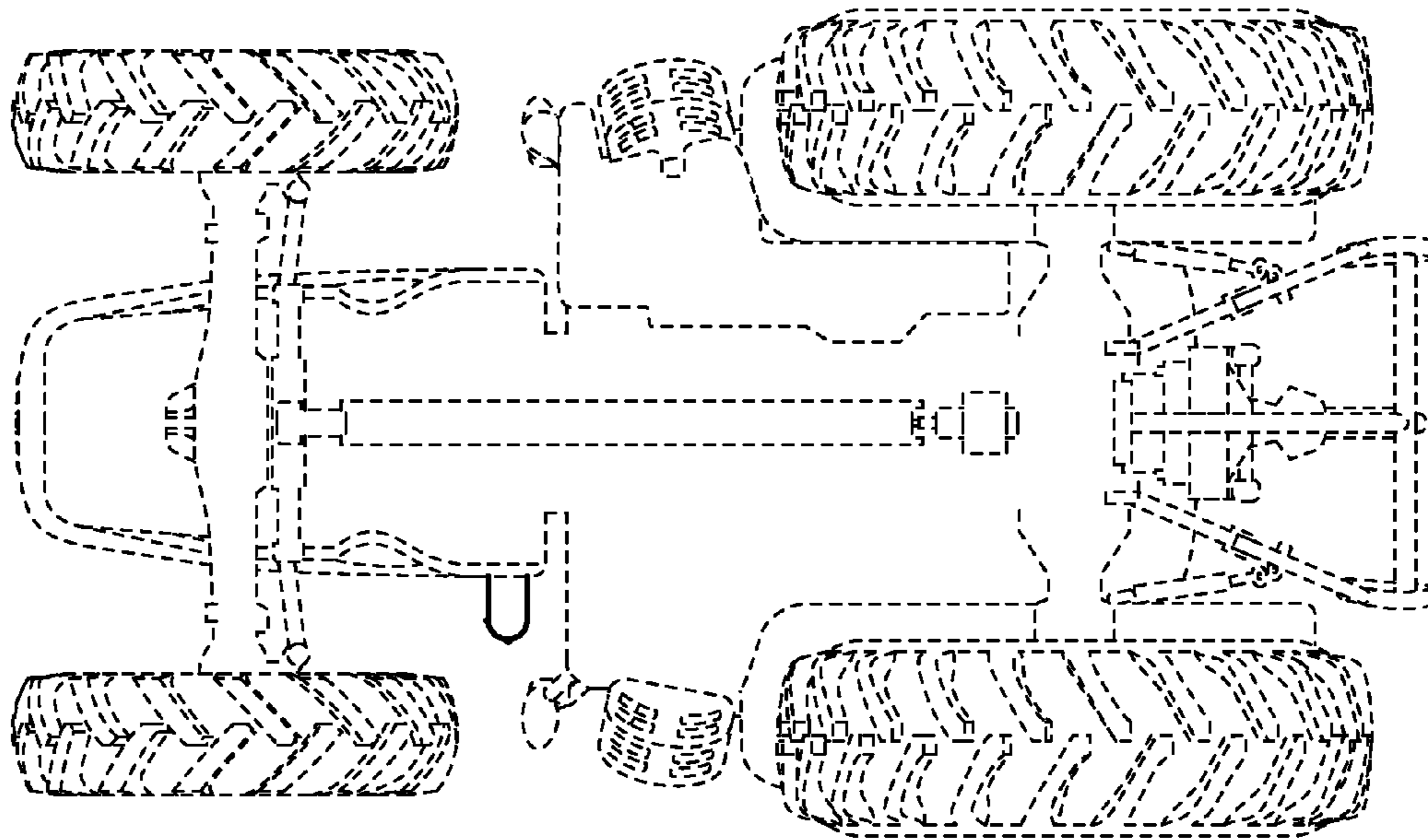

FIG. 7