



US00D693025S

(12) **United States Design Patent**
Fannan

(10) **Patent No.:** **US D693,025 S**
(45) **Date of Patent:** **** Nov. 5, 2013**

(54) **WINDOW COMPONENT EXTRUSION**

(75) Inventor: **Michael R. Fannan**, Pecatonica, IL (US)

(73) Assignee: **Mikron Industries, Inc.**, Kent, WA (US)

(**) Term: **14 Years**

(21) Appl. No.: **29/421,649**

(22) Filed: **Aug. 24, 2012**

(51) **LOC (9) Cl.** **25-01**

(52) **U.S. Cl.**
USPC **D25/124**

(58) **Field of Classification Search**

USPC D25/124; 52/204.1, 204.2, 204.5,
52/204.51, 656.5, 656.6, 213, 215, 208,
52/206, 212, 717.01, 209, 204.72, 579,
52/793.1, 794.1, 216, 204.55, 656.2,
52/656.7; 49/DIG. 2, 504, 501, 449, 180,
49/183, 505

See application file for complete search history.

(56) **References Cited**

U.S. PATENT DOCUMENTS

D442,292	S *	5/2001	Habeck et al.	D25/124
D454,212	S *	3/2002	Ballard et al.	D25/124
6,857,232	B2 *	2/2005	Bealko	52/211
7,845,135	B2 *	12/2010	Sibbett	52/656.9
D640,802	S *	6/2011	Fannan	D25/124
2006/0026913	A1 *	2/2006	Turner	52/204.5
2009/0000225	A1 *	1/2009	Ito et al.	52/204.5

* cited by examiner

Primary Examiner — Doris Clark

(74) *Attorney, Agent, or Firm* — Zollinger & Bursleson Ltd.

(57) **CLAIM**

The ornamental design for a window component extrusion, as shown and described.

DESCRIPTION

FIG. 1 is a top right perspective view of a first embodiment of the window component extrusion which is broken in the center indicating indefinite length, FIG. 2 is a bottom left perspective view of the window component extrusion shown in FIG. 1, FIG. 3 is a top right perspective view of a second embodiment of the window component extrusion which is broken in the center indicating indefinite length, FIG. 4 is a bottom left perspective view of the window component extrusion shown in FIG. 3, FIG. 5 is a top right perspective view of a third embodiment of the window component extrusion which is broken in the center indicating indefinite length, FIG. 6 is a bottom left perspective view of the window component extrusion shown in FIG. 5, FIG. 7 is a top right perspective view of a fourth embodiment of the window component extrusion which is broken in the center indicating indefinite length, FIG. 8 is a bottom left perspective view of the window component extrusion shown in FIG. 7, FIG. 9 is a top right perspective view of a fifth embodiment of the window component extrusion which is broken in the center indicating indefinite length, FIG. 10 is a bottom left perspective view of the window component extrusion shown in FIG. 9, FIG. 11 is a top right perspective view of a sixth embodiment of the window component extrusion which is broken in the center indicating indefinite length; and, FIG. 12 is a bottom left perspective view of the window component extrusion shown in FIG. 11.

1 Claim, 6 Drawing Sheets

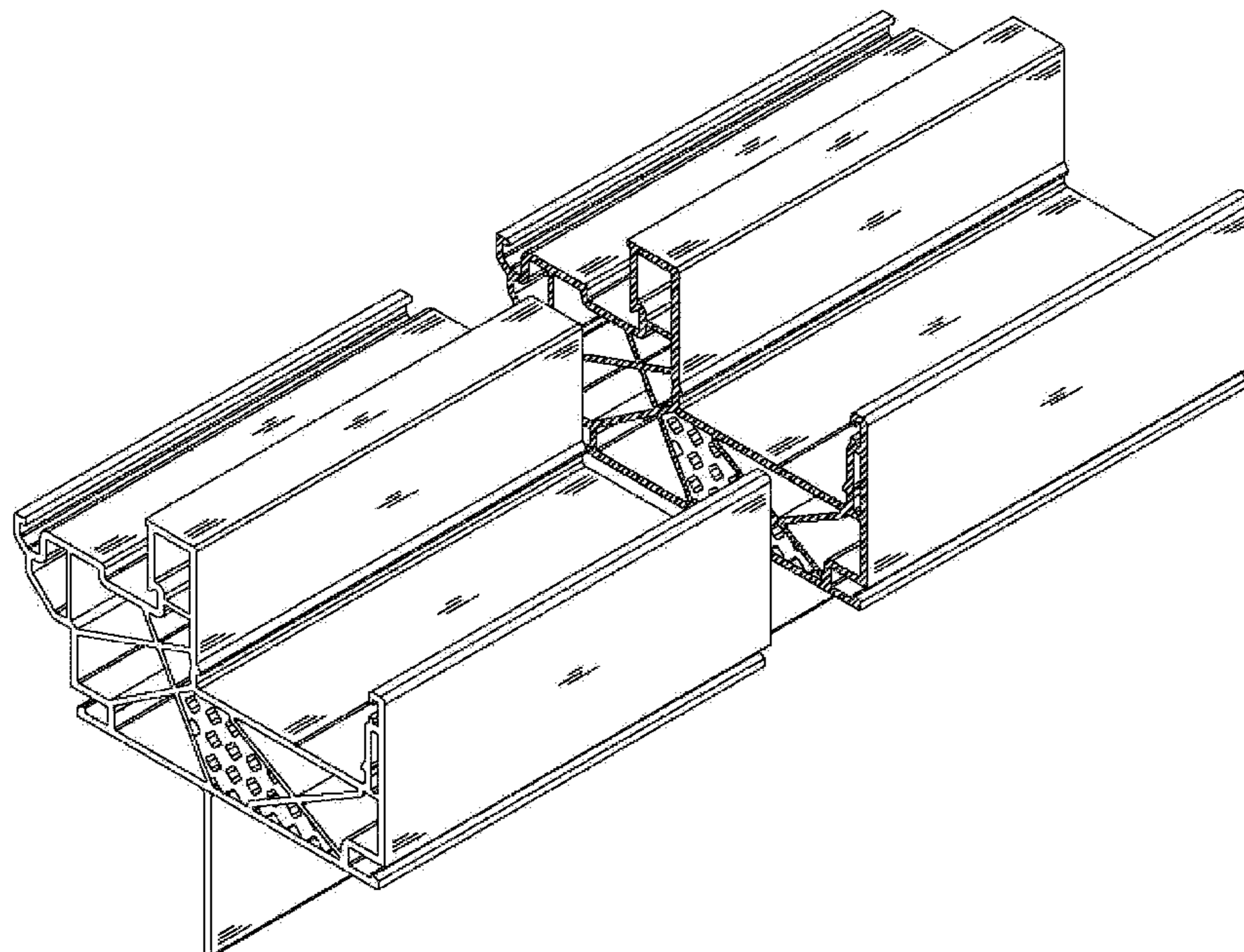

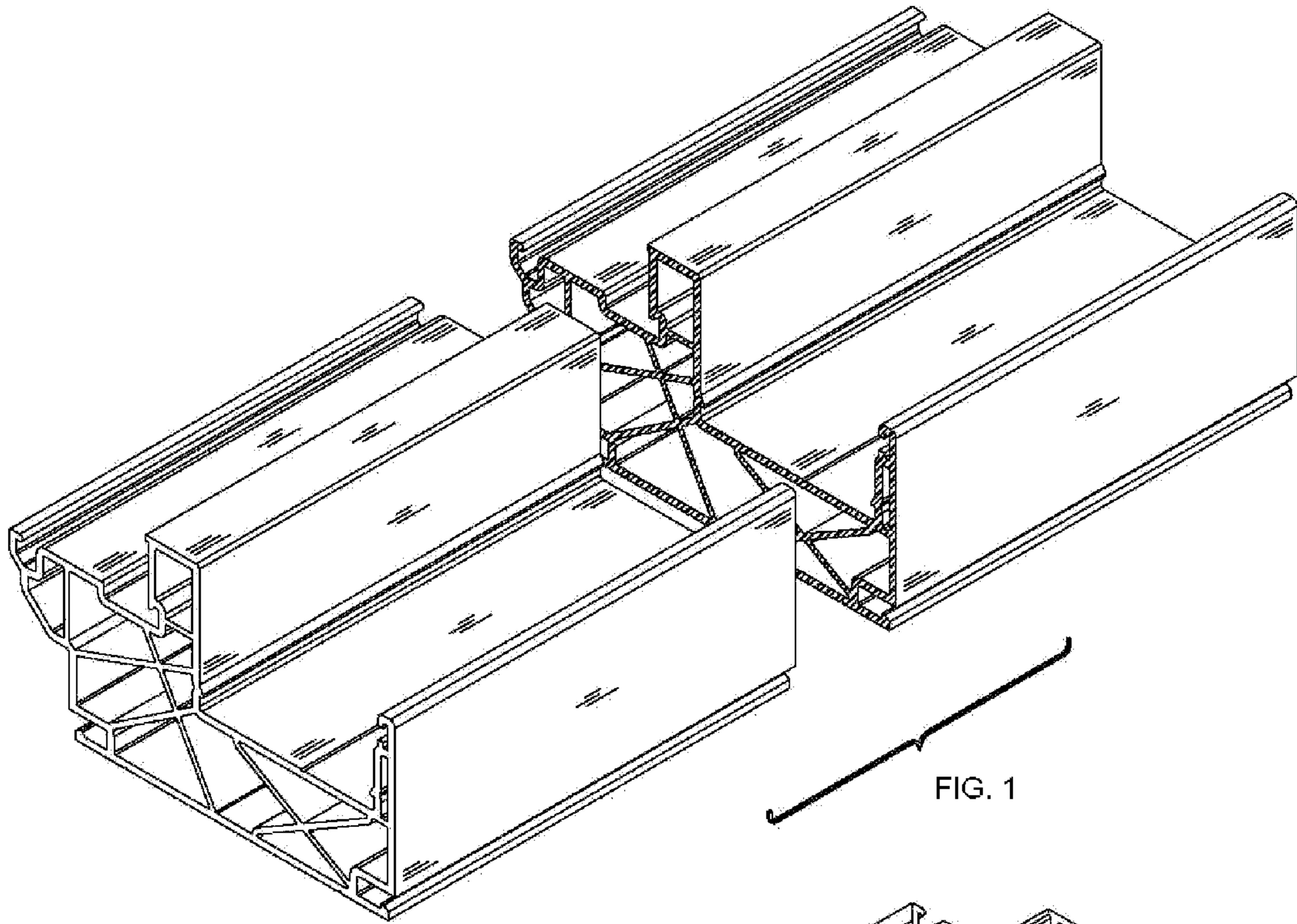

FIG. 1

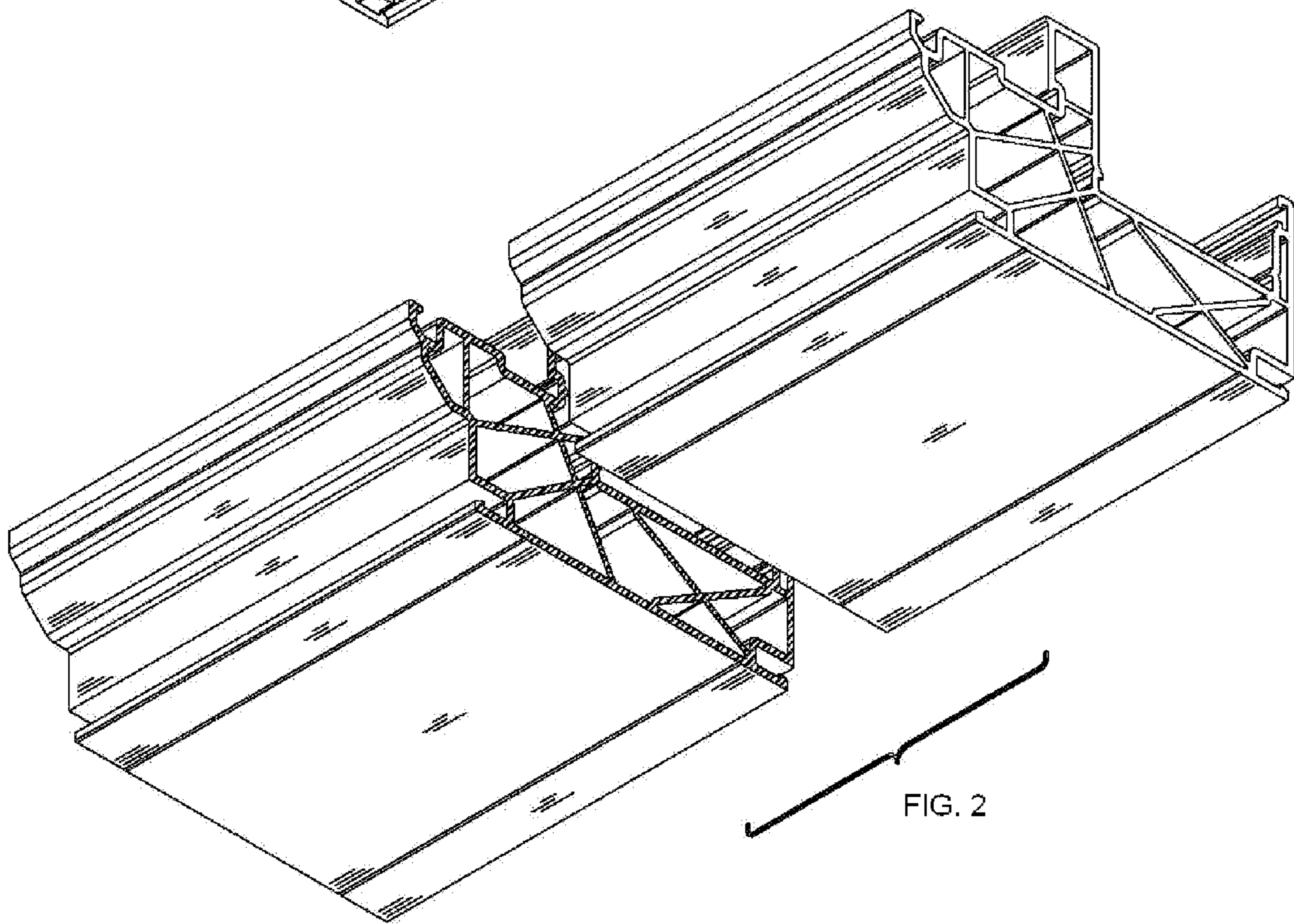
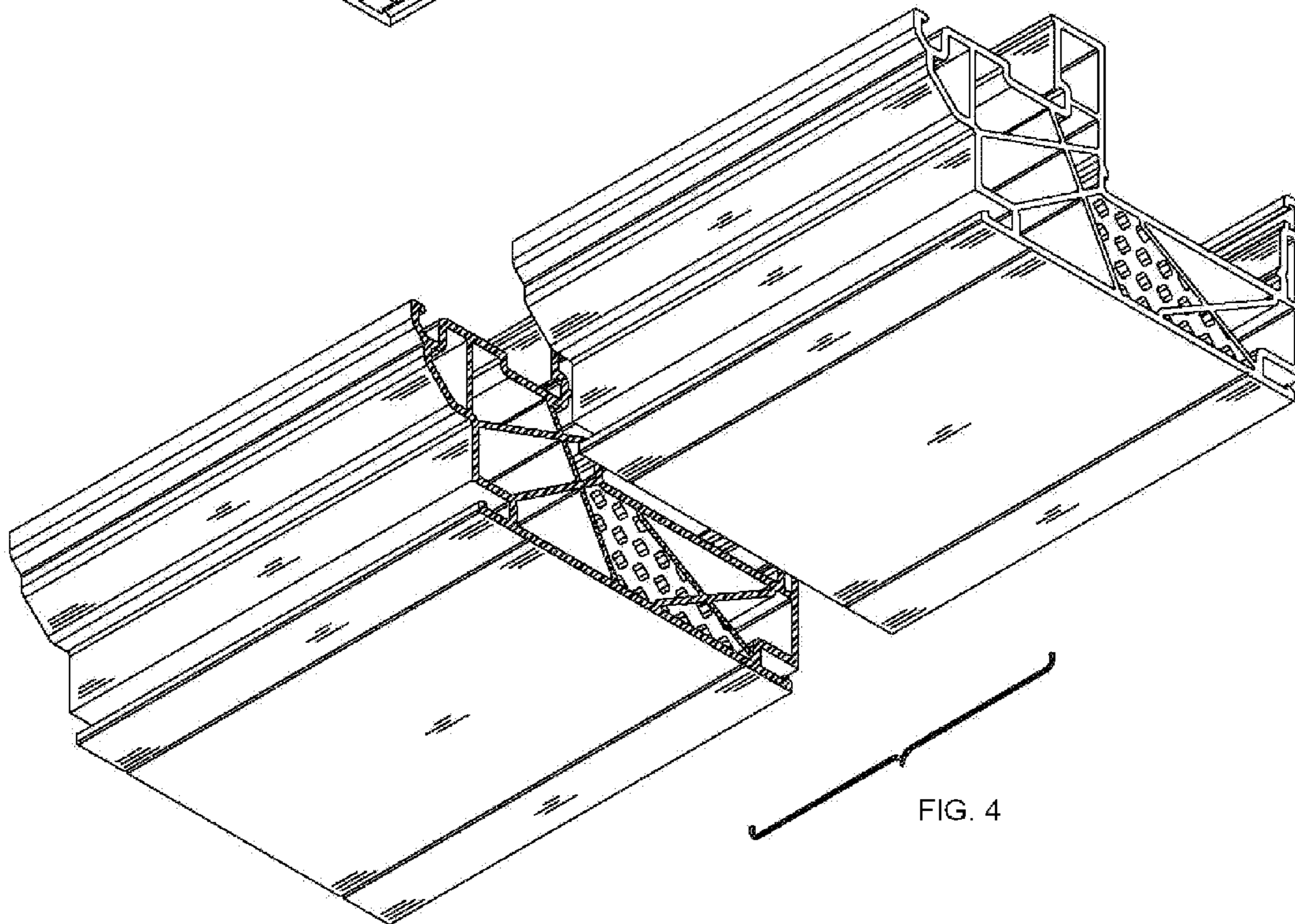
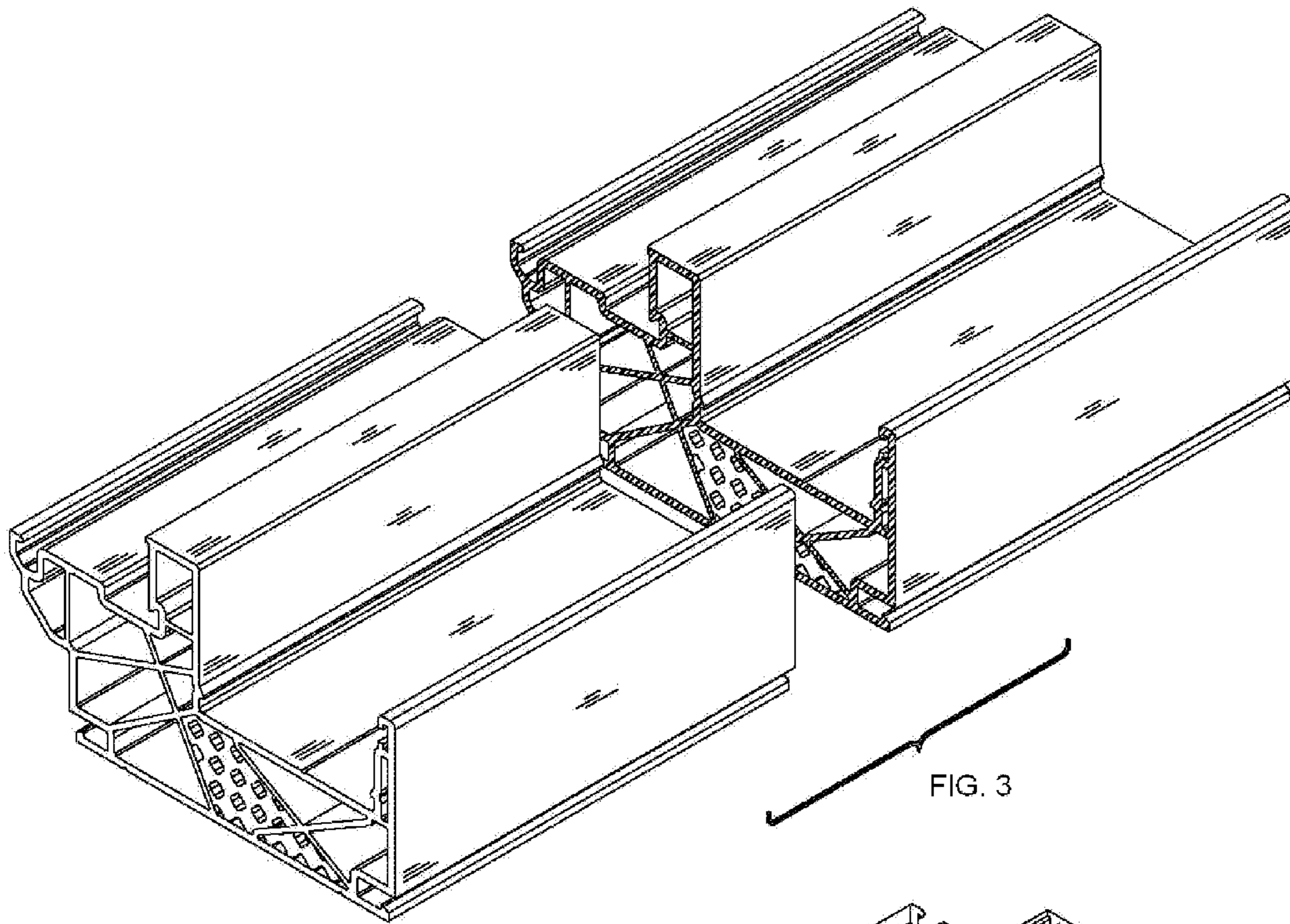

FIG. 2



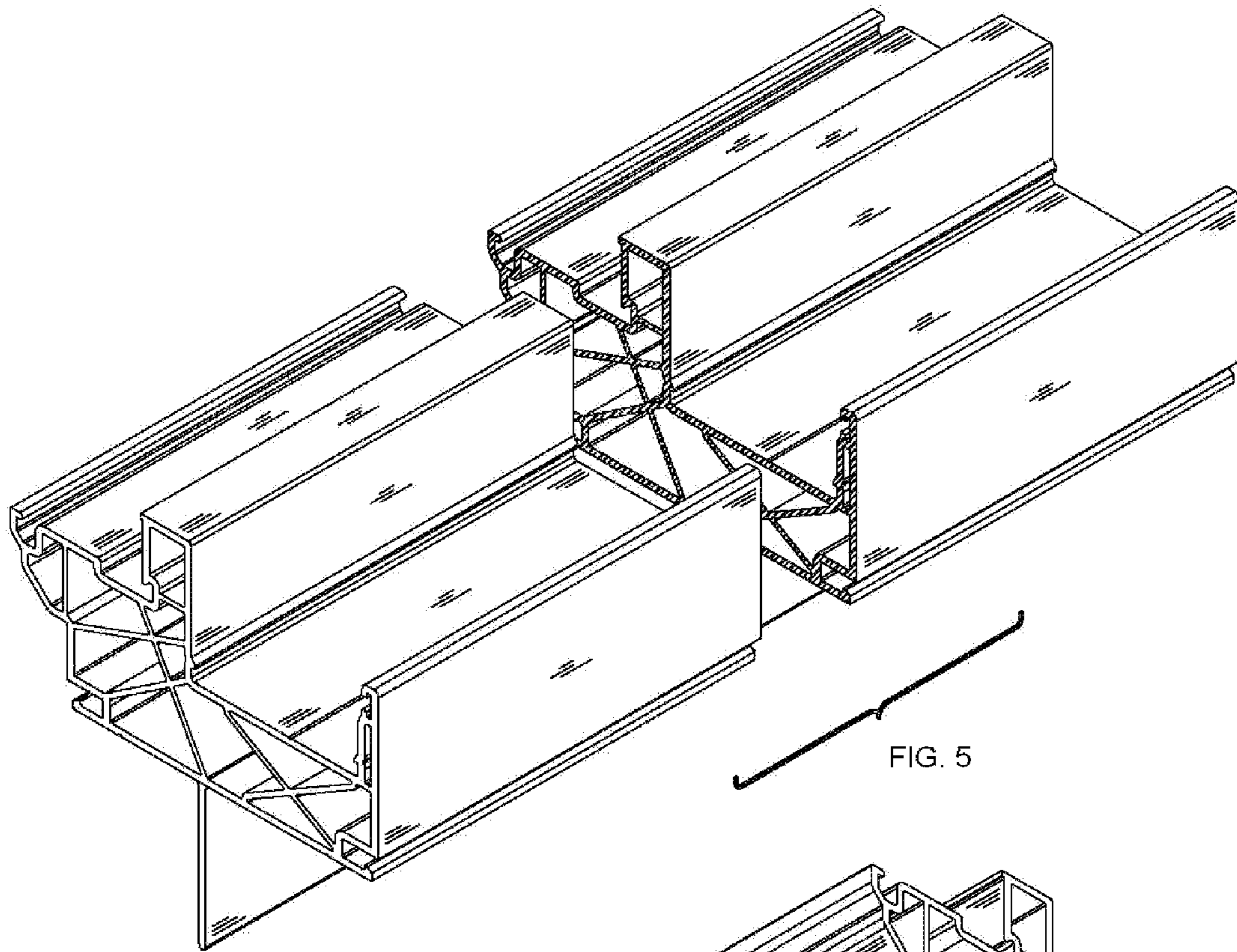

FIG. 5

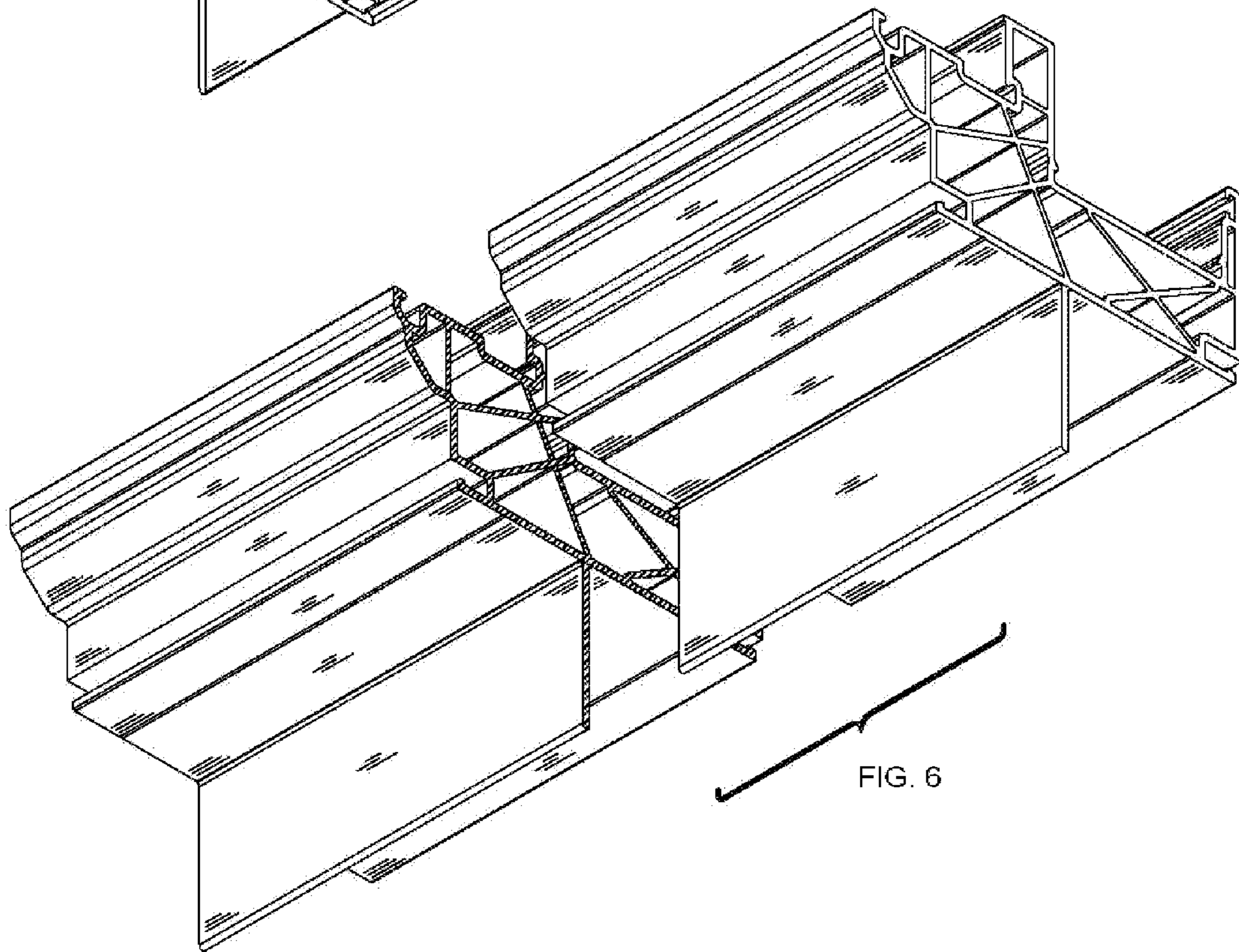

FIG. 6

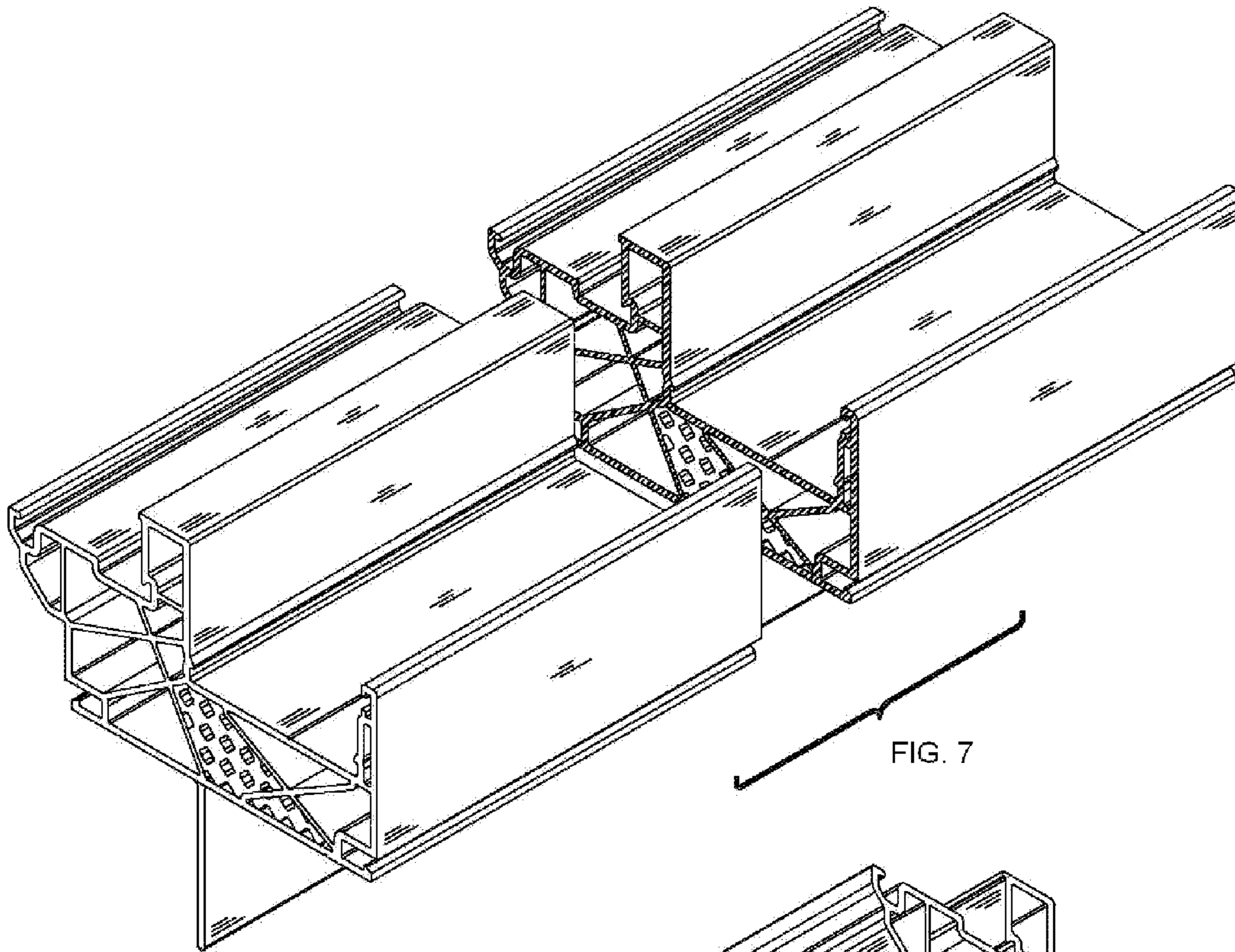

FIG. 7

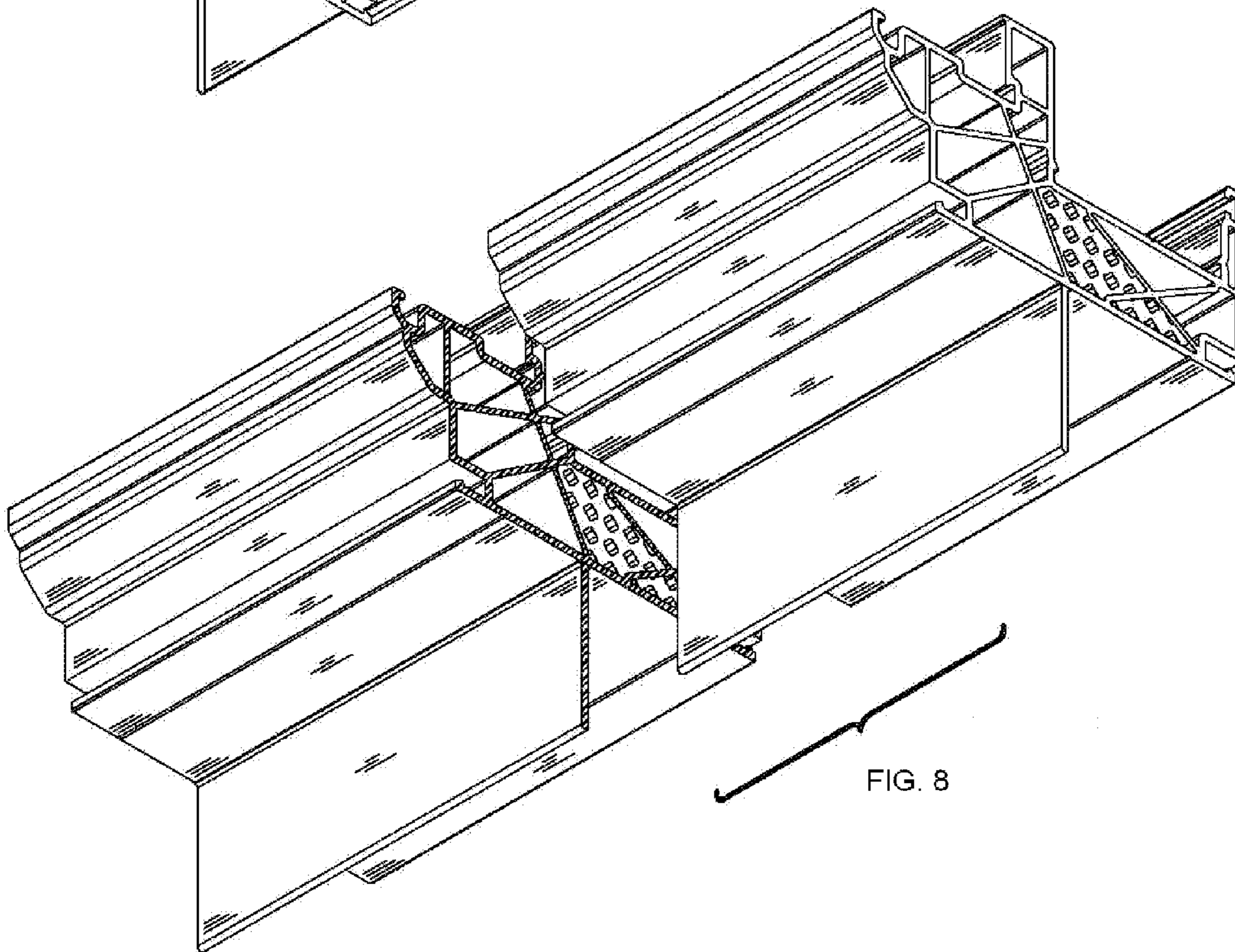
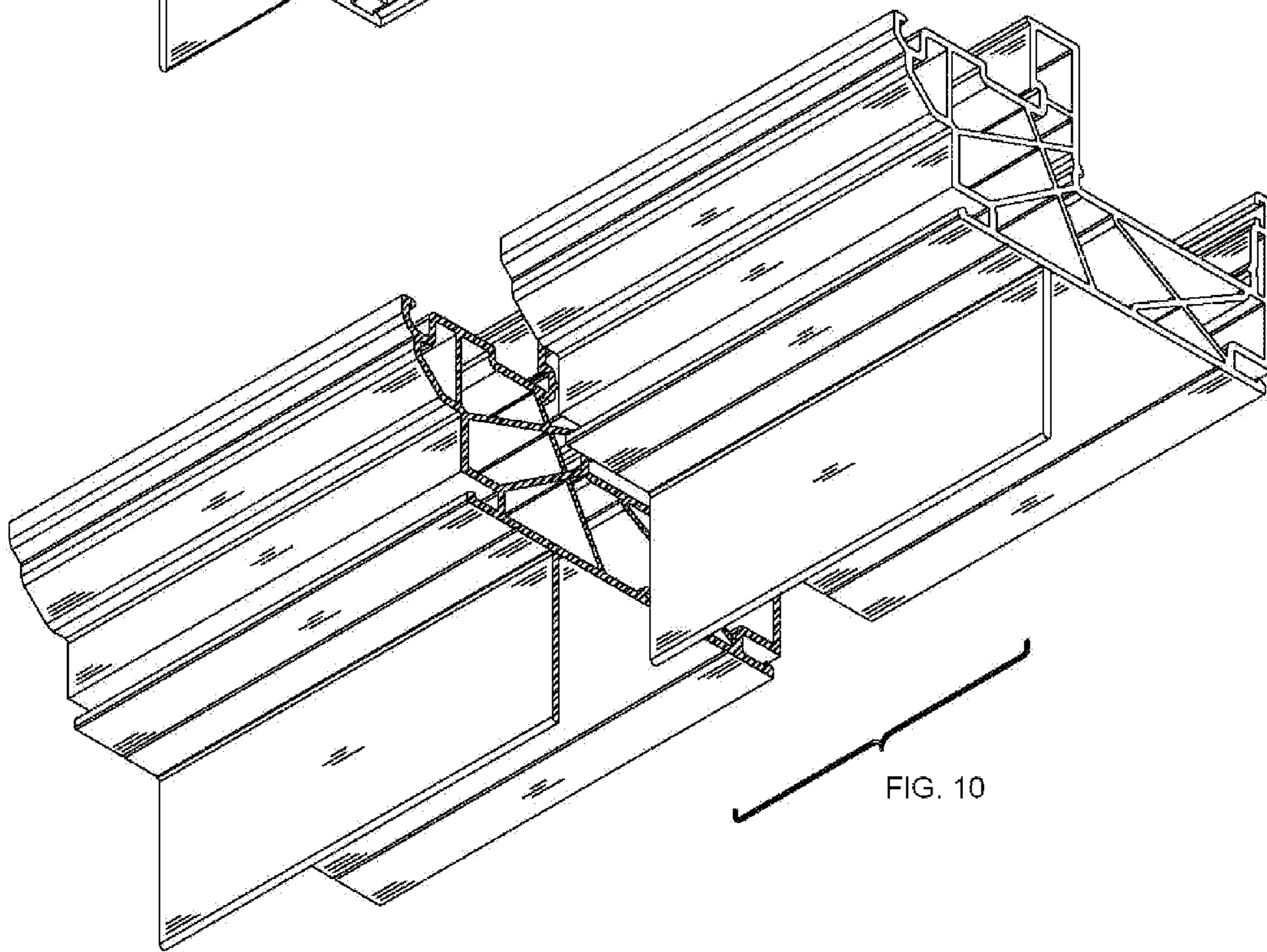
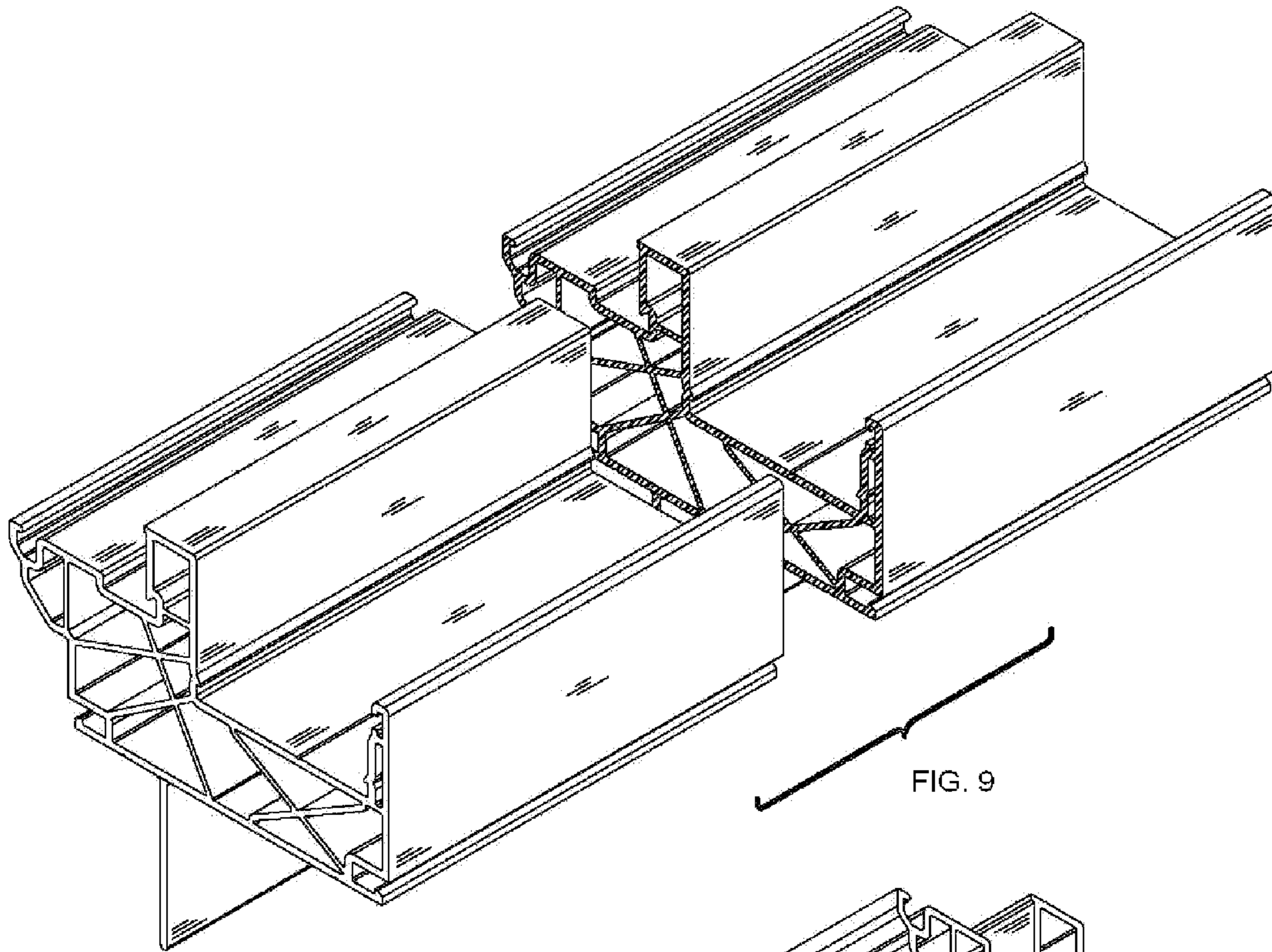

FIG. 8



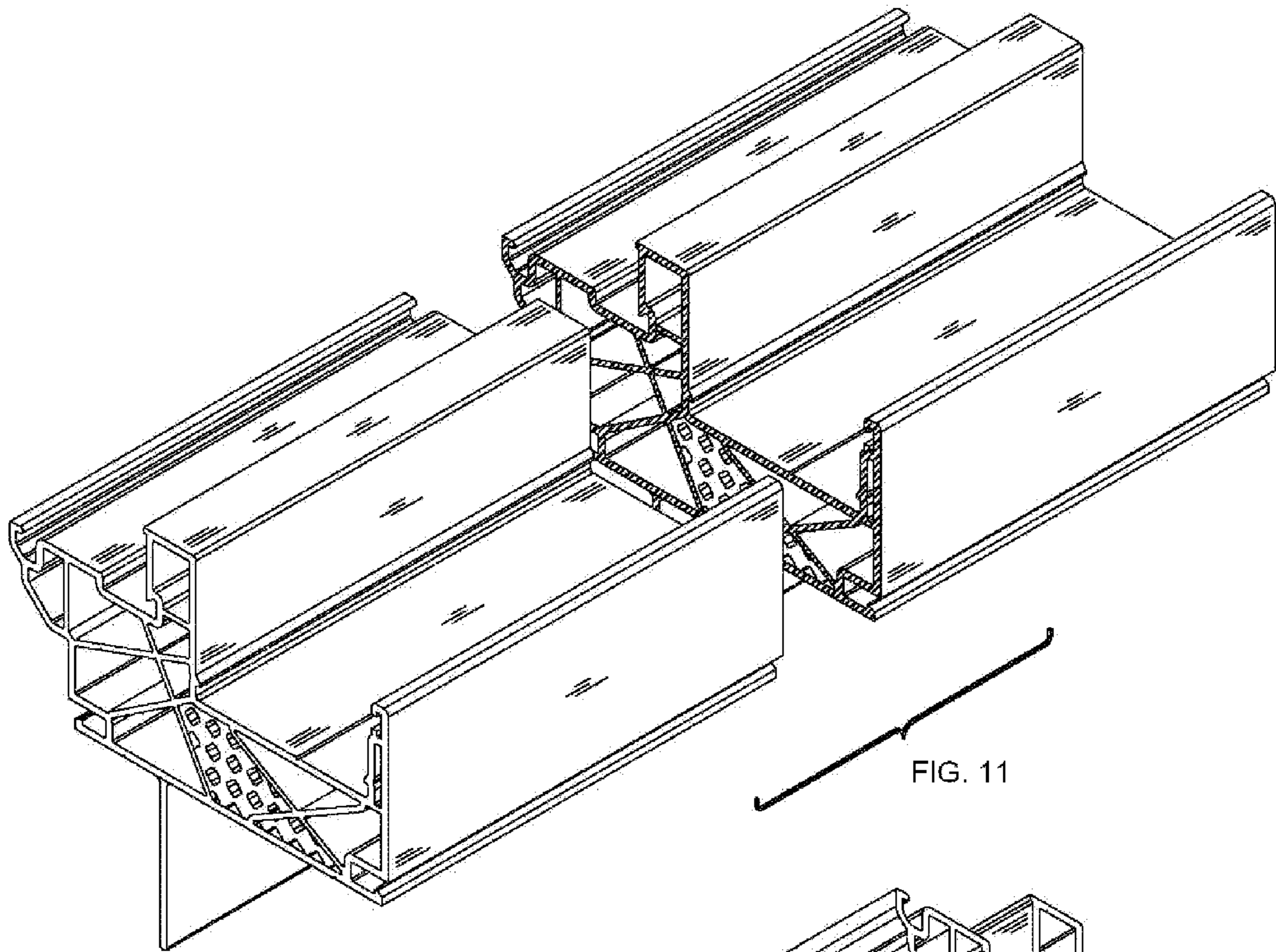

FIG. 11

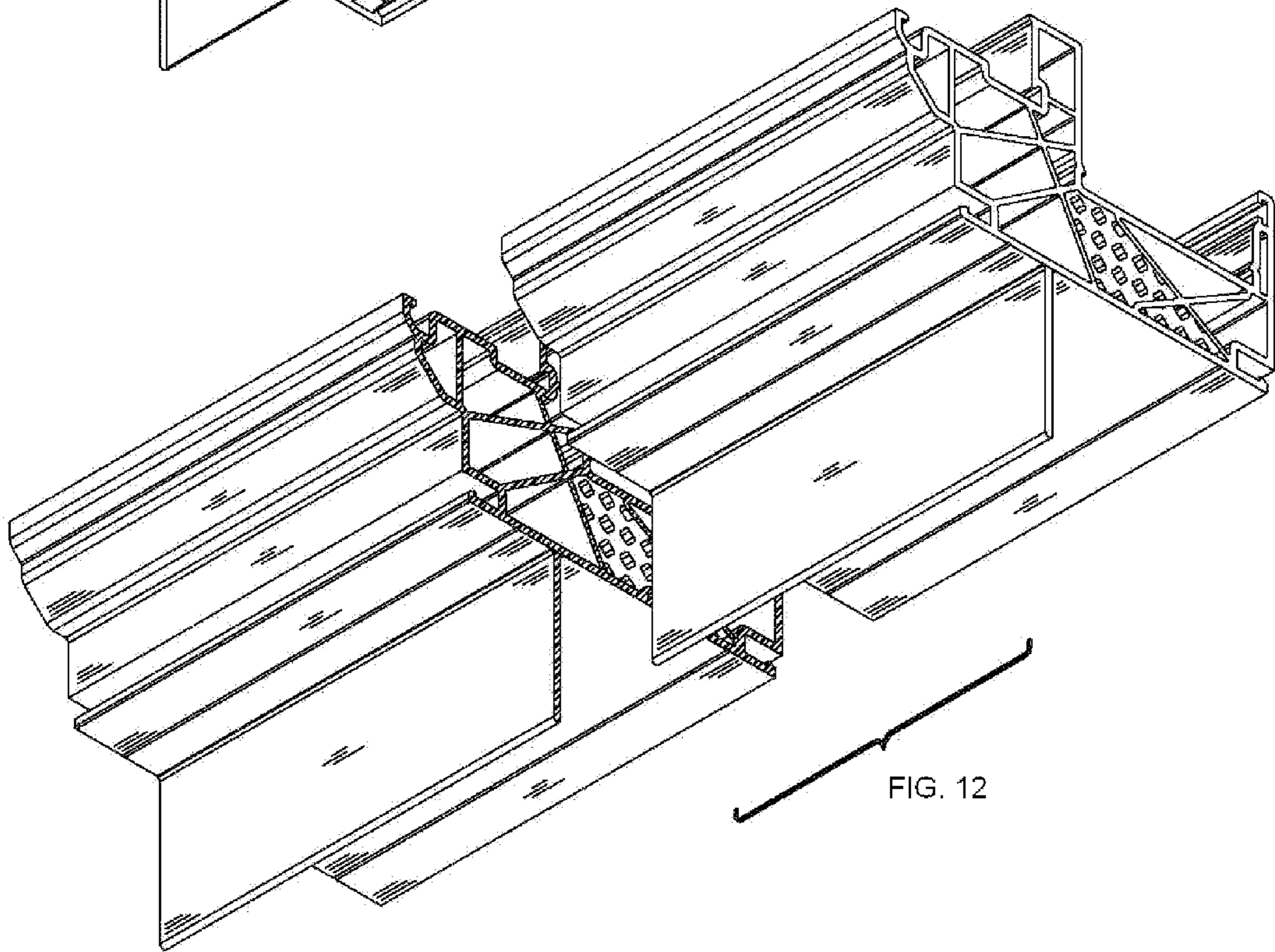

FIG. 12